

**Collaborative Spaces**

Effective April 2024 Canada

PRICELIST

# collaborative spaces



## Technical Notes

- All tables are available in HP - High Pressure Laminate (1-1/16" thick) or LP - Low Pressure Laminate (1" thick) with flat edge.
- Surfaces constructed of 45lb. density particleboard substructure with low pressure laminate or optional high pressure laminate.
- All tables are PVC 3mm edge banded.
- Grommet location must be specified at the time of order or it will default to a no grommet option.
- Power modules and grommets are not included, they must be specified separately.
- Table legs and bases are painted aluminum finish.
- Tables are shipped knocked down and must assembled on site.
- Cart shelf load capacities : 120 lbs for 42" wide (Hospitality Cart), 140 lbs for 48" wide and 175 lbs for 60" wide.
- Casters cannot be used with TV Mount units and wire basket for tables larger than 78" long.

## DIMENSIONS

Corner radius for small radius table tops is 1.5".

Corner radius for large radius tables tops is 9".

Top end overhang for large tables is 10.5"

Worksurface support beams and footrests (where applicable) are centered for tables 18" and 24" deep.

Worksurface support beams and footrests (where applicable) are 9" from the outside table edges for tables 30" deep.

Worksurface support beams and footrests (where applicable) are 12" from the outside table edges for tables 36 to 48" deep.

## GENERAL NOTES

- GREENGUARD certified ([www.greenguard.org](http://www.greenguard.org))
- Carb compliant
- Level3™ certified ([www.levelcertified.org](http://www.levelcertified.org))
- Tested to meet or exceed ANSI/BIFMA X5.9.2019 , ANSI/ BIFMA X5.5.2021 and CAN/CGSB 44-227-2008
- Plant is ISO 9001:2015 (Quality) certified
- Plant is ISO 14001: 2015 (Environmental) certified
- Plant is OHSAS 18001:2007 (Health and Safety) certified
- 100% made in Canada
- Lifetime Warranty

## STORAGE AND WORKSURFACE FINISHES

### Metal Storage Colors - Panel Frame

#### Matches

Black	BLK
Blizzard	BZD
Charcoal	CHR
Designer White	DWT
Ink	TIN
Nevada	NEV
Silver	SIL
Stonedust	SDT
Taupe	TPE
Tungsten	TUN

### PVC Edge Finishes - Panel Frame

#### Matches

Black	BLK
Blizzard	BZD
Brushed Cobalt	BRC
Charcoal	CHR
Designer White	DWE
Nevada	NEV
Silver	SIL
Stonedust	SDT
Taupe	TPE
Tungsten	TUN

### Worksurface PVC Edge Trim - Wood

#### Grain Matches

Absolute Acajou	AAE	Noce Leggero	NEL
Asian Night	ASE	Noce Medio	NML
Avant Cherry	ACE	Quartered Mahogany	QTM
Avant Honey	AHE	Sheer Beauty	SBY
Clear Maple	CME	Walnut Heights	WHE
Dark Espresso	DEE	White Chocolate	CBE
Fashionista	FAS	Winter Cherry	WCE
First Class	FCL		
Noce Biondo	NBL		
Noce Grigio	NGL		

### Low Pressure Laminates (LP) Panel

#### Frame Matches

Black	BLKLP
Blizzard	BZDLP
Brushed Cobalt (Tungsten)	BRCLP
Custom Grey (Silver)	CGYLP
Designer White	DWTLP
Hayden Grey (Taupe)	HGTLP
Stonedust	SDTLP
Storm Grey (Charcoal)	SOGLP
String (Nevada)	STGLP

### Low Pressure Laminates (LP) Solids

#### and Patterns

Blizzard Matrix	BMXLP
Grey Matrix	GRXLP
Hayden Linen	HLNLP
Stone Linen	SLNLP
Studio White Matrix	SWXLP

### Low Pressure Laminates (LP) Wood

#### Grain Laminates

Absolute Acajou	ACJLP	Noce Leggero	NELLP
Asian Night	ASNLP	Noce Medio	NMLLP
Avant Cherry	AWCLP	Quartered Mahogany	QTM LP
Avant Honey	AWHLP	Sheer Beauty	SBYLP
Clear Maple	CMBLP	Walnut Heights	WHELP
Dark Espresso	DESLP	White Chocolate	WHCLP
Fashionista	FASLP	Winter Cherry	WCRLP
First Class	FCLLP		
Noce Biondo	NBLLP		
Noce Grigio	NGLLP		

### High Pressure Laminates (HP)

#### Panel Frame Matches

Black	BLKHP
Blizzard	BZDHP
Brushed Cobalt (Tungsten)	BRCHP
Custom Grey (Silver)	CGYHP
Designer White	DWTHP
Hayden Grey (Taupe)	HGTHP
Stonedust	SDTHP
Storm Grey (Charcoal)	SOGHP
String (Nevada)	STGHP

### High Pressure Laminates (HP)

#### Solids and Patterns

Blizzard Matrix	BMXHP
Grey Matrix	GRXHP
Hayden Linen	HLNHP
Stone Linen	SLNHP
Studio White Matrix	SWXHP

### High Pressure Laminates (HP) Wood

#### Grain Laminates

Absolute Acajou	ACJHP	Noce Leggero	NELHP
Asian Night	ASNHP	Noce Medio	NMLHP
Avant Cherry	AWCHP	Quartered Mahogany	QTMHP
Avant Honey	AWHHP	Sheer Beauty	SBYHP
Clear Maple	CMBHP	Walnut Heights	WHEHP
Dark Espresso	DESHP	White Chocolate	WHCHP
Fashionista	FASHP	Winter Cherry	WCRHP
First Class	FCLHP		
Noce Biondo	NBLHP		
Noce Grigio	NGLHP		

### Caster Finish

Black	BLK
Grey	GRC

**Grommet Locations**

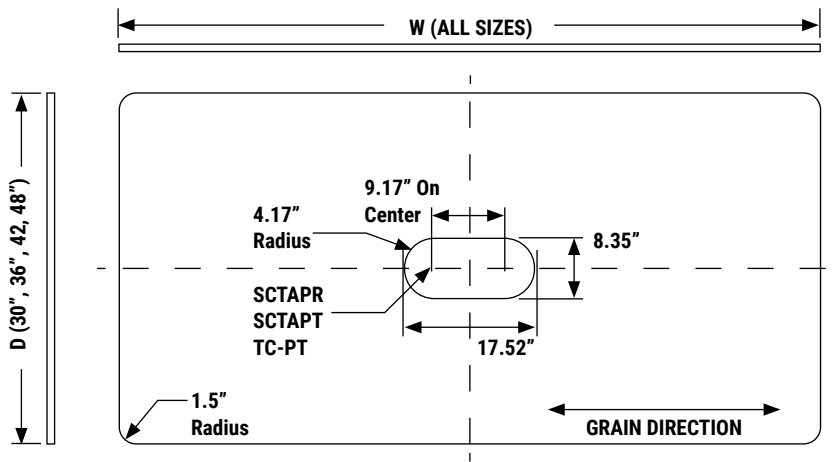

- NOTES:**
1. Cutout not available for 18" and 24" Deep Tables.
  2. Cutout Position TC available only.
  3. These rules apply to both Small and Large Radius Table Tops. Small Radius Top Shown.

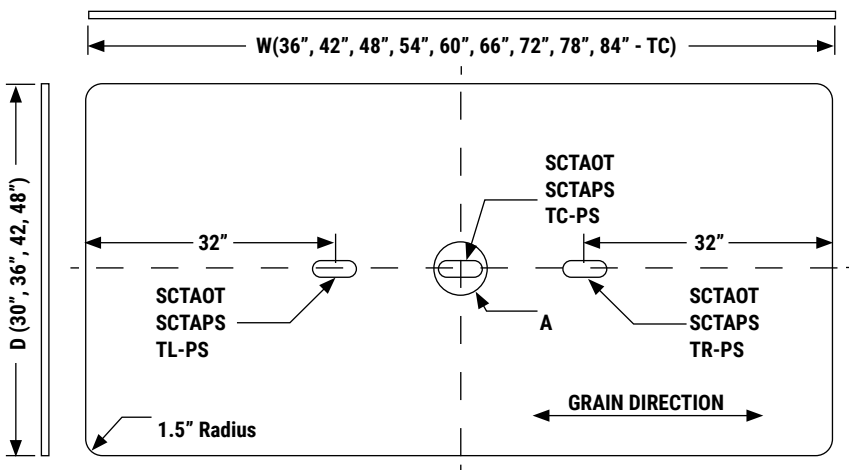

- NOTES:**
1. Cutout not available for 18" and 24" Deep Tables.
  2. SCTAOT/SCTAPS/TL TR Available only for 90" & 96" WIDE TABLES.
  3. These rules apply to both Small and Large Radius Table Tops. Small Radius Top Shown.

**Spaces Collaborative Specifications**

**HOW TO SPECIFY :**

**Example:** SCTWSL2472

<b>SC</b>	Space Collaborative	
<b>T</b>	Table	
<b>W</b>	Work Height Table - 29"	Other Options: C - Café Height Table - 36" B - Bar Height Table - 42"
<b>S</b>	Small Radius - 1.5"	Other Options: L - Large Radius - 9"
<b>L</b>	Levelers	Other Options: C - Casters - Available in BLK - Black or GRC - Grey
<b>24</b>	Depth	
<b>72</b>	Width	
<b>LP</b>	Low Pressure Laminate	Other Options: HP - High Pressure

**Choose:** Laminate Finish  
Edging  
Paint  
Grommet location as per chart

**SCTWD • Core Collaboration Table, 29" Work Height, Small Radius, Levelers**

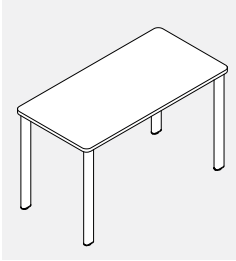

- Core Work Height Collaboration Tables on levelers consist of four individual legs and one surface with a small 1.5" radius at each corner.
- Surface available in LP - Low Pressure or HP - High Pressure laminates.
- Legs are painted extruded aluminum. Levelers have 1" adjustment for leveling.
- Tables from 48" to 72" include a center worksurface support beam
- Center worksurface support beam eliminates the possibility of a grommet cutout.

PRODUCT CODE	PRICE		SIZE/INCHES			WEIGHT LBS	VOL FT <sup>3</sup>
	LP	HP	H	W	D		
SCTWD1836	587	658	29	36	18	35.54	2.33
SCTWD1842	612	695	29	42	18	38.52	2.52
SCTWD1848	676	771	29	48	18	47.06	2.71
SCTWD1854	708	815	29	54	18	50.88	2.90
SCTWD1860	734	896	29	60	18	54.70	3.08
SCTWD1866	769	946	29	66	18	58.52	3.27
SCTWD1872	803	997	29	72	18	62.34	3.46
SCTWD2436	631	725	29	36	24	41.51	3.11
SCTWD2442	662	772	29	42	24	45.49	3.36
SCTWD2448	732	858	29	48	24	55.02	3.61
SCTWD2454	770	912	29	54	24	59.83	3.86
SCTWD2460	802	1015	29	60	24	64.65	4.11
SCTWD2466	843	1077	29	66	24	69.46	4.36
SCTWD2472	884	1138	29	72	24	74.27	4.61
SCTWD3036	674	792	29	36	30	47.47	3.89
SCTWD3042	712	850	29	42	30	52.45	4.20
SCTWD3048	788	945	29	48	30	62.98	4.51
SCTWD3054	832	1010	29	54	30	68.78	4.83
SCTWD3060	871	1134	29	60	30	74.59	5.14
SCTWD3066	918	1207	29	66	30	80.40	5.45
SCTWD3072	964	1280	29	72	30	86.20	5.76

**SCTWSL • Standard Collaboration Table, 29" Work Height, Small Radius, Levelers**

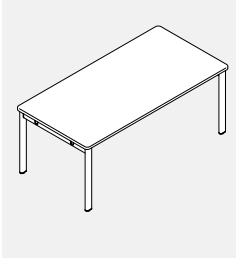

- Work Height Collaboration Tables on levelers consist of two leg assemblies, worksurface support beams and one worksurface with a small 1.5" radius at each corner.
- Surface available in LP - Low Pressure or HP - High Pressure laminates.
- Legs are painted extruded aluminum. Levelers have 1" adjustment for leveling.
- Cutouts for power modules are limited to specific sizes/configurations, please see Grommet Location Chart.
- 18" and 24" deep tables feature one worksurface support beam.
- 30" deep tables feature two worksurface support beams.

PRODUCT CODE	PRICE		SIZE/INCHES			WEIGHT LBS	VOL FT <sup>3</sup>
	LP	HP	H	W	D		
SCTWSL1836	899	970	29	36	18	40.05	2.33
SCTWSL1842	957	1040	29	42	18	43.65	2.52
SCTWSL1848	1140	1235	29	48	18	50.15	2.71
SCTWSL1854	1166	1272	29	54	18	53.75	2.90
SCTWSL1860	1213	1331	29	60	18	57.34	3.08
SCTWSL1866	1239	1368	29	66	18	60.93	3.27
SCTWSL1872	1301	1443	29	72	18	64.52	3.46
SCTWSL1878	1326	1480	29	78	18	68.12	3.65
SCTWSL1884	1352	1517	29	84	18	71.71	3.83
SCTWSL1890	1451	1628	29	90	18	75.31	4.02
SCTWSL1896	1476	1665	29	96	18	78.90	4.21
SCTWSL2436	967	1062	29	36	24	43.05	3.11
SCTWSL2442	1032	1142	29	42	24	46.65	3.36
SCTWSL2448	1221	1347	29	48	24	53.15	3.61
SCTWSL2454	1252	1394	29	54	24	56.75	3.86
SCTWSL2460	1306	1463	29	60	24	60.34	4.11
SCTWSL2466	1337	1511	29	66	24	63.93	4.36
SCTWSL2472	1406	1595	29	72	24	67.52	4.61
SCTWSL2478	1437	1642	29	78	24	71.12	4.86
SCTWSL2484	1469	1689	29	84	24	74.71	5.11
SCTWSL2490	1574	1810	29	90	24	78.31	5.36
SCTWSL2496	1606	1857	29	96	24	81.90	5.61
SCTWSL3036	1162	1280	29	36	30	46.05	3.89
SCTWSL3042	1266	1404	29	42	30	49.65	4.20
SCTWSL3048	1483	1641	29	48	30	56.15	4.51
SCTWSL3054	1521	1698	29	54	30	59.75	4.83
SCTWSL3060	1603	1800	29	60	30	63.34	5.14
SCTWSL3066	1641	1857	29	66	30	66.93	5.45
SCTWSL3072	1752	1988	29	72	30	70.52	5.76
SCTWSL3078	1808	2064	29	78	30	74.12	6.08
SCTWSL3084	1845	2121	29	84	30	77.71	6.40
SCTWSL3090	2030	2326	29	90	30	81.31	6.71
SCTWSL3096	2068	2383	29	96	30	84.90	7.02

**SCTCSL • Standard Collaboration Table, 36" Café Height, Small Radius, Levelers**

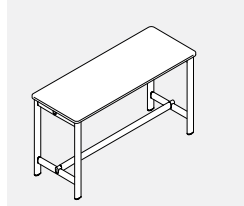

For 18" and 24" deep surfaces

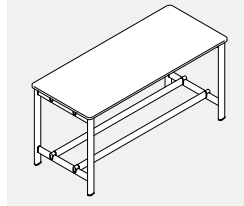

For 30" deep tables, 36" to 72" wide

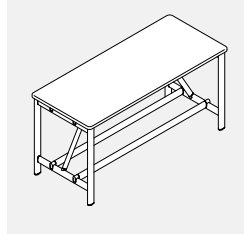

For 30" deep tables, 78" to 96" wide

- Café Height Collaboration Tables on levelers consist of two leg assemblies, worksurface support beam(s), footrest(s) and one worksurface with a small 1.5" radius at each corner.
- Surface available in LP - Low Pressure or HP - High Pressure laminates.
- Legs are painted extruded aluminum.
- Levelers have 1" adjustment for leveling.
- Cutouts for power modules are limited to specific sizes/configurations, please see Grommet Location Chart.
- Tables 18" and 24" deep feature one worksurface support beam and one footrest.
- Tables 30" deep feature two worksurface support beams and two footrests.
- Tables 30" deep and 78" wide and greater include a reinforcement cantilever for added stability.

PRODUCT CODE	PRICE		SIZE/INCHES			WEIGHT LBS	VOL FT <sup>3</sup>
	LP	HP	H	W	D		
SCTCSL1836	1277	1348	36	36	18	50.14	2.33
SCTCSL1842	1369	1452	36	42	18	54.34	2.52
SCTCSL1848	1551	1645	36	48	18	61.46	2.71
SCTCSL1854	1576	1682	36	54	18	65.66	2.90
SCTCSL1860	1646	1764	36	60	18	69.87	3.08
SCTCSL1866	1671	1801	36	66	18	74.07	3.27
SCTCSL1872	1770	1912	36	72	18	78.28	3.46
SCTCSL1878	1796	1949	36	78	18	82.48	3.65
SCTCSL1884	1821	1987	36	84	18	86.69	3.83
SCTCSL1890	1994	2171	36	90	18	90.90	4.02
SCTCSL1896	2019	2208	36	96	18	95.10	4.21
SCTCSL2436	1370	1465	36	36	24	67.83	3.11
SCTCSL2442	1468	1578	36	42	24	74.58	3.36
SCTCSL2448	1656	1782	36	48	24	84.23	3.61
SCTCSL2454	1687	1829	36	54	24	90.98	3.86
SCTCSL2460	1763	1921	36	60	24	97.73	4.11
SCTCSL2466	1795	1968	36	66	24	104.48	4.36
SCTCSL2472	1900	2089	36	72	24	111.23	4.61
SCTCSL2478	1931	2136	36	78	24	117.98	4.86
SCTCSL2484	1963	2183	36	84	24	124.73	5.11
SCTCSL2490	2142	2378	36	90	24	131.48	5.36
SCTCSL2496	2173	2425	36	96	24	138.23	5.61
SCTCSL3036	1717	1835	36	36	30	86.09	3.89
SCTCSL3042	1887	2025	36	42	30	95.44	4.20
SCTCSL3048	2081	2239	36	48	30	107.70	4.51
SCTCSL3054	2119	2296	36	54	30	117.05	4.83
SCTCSL3060	2245	2442	36	60	30	126.41	5.14
SCTCSL3066	2282	2499	36	66	30	135.76	5.45
SCTCSL3072	2468	2704	36	72	30	145.11	5.76
SCTCSL3078	2651	2906	36	78	30	156.91	6.08
SCTCSL3084	2688	2964	36	84	30	166.26	6.70
SCTCSL3090	3021	3316	36	90	30	175.62	6.39
SCTCSL3096	3058	3373	36	96	30	184.97	7.01

**SCTBSL • Standard Collaboration Table, 42" Bar Height, Small Radius, Levelers**



For 18" and 24" deep surfaces

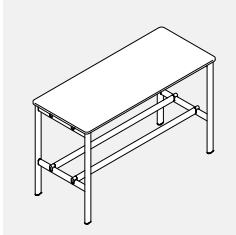

For 30" deep tables, 36" to 72" wide

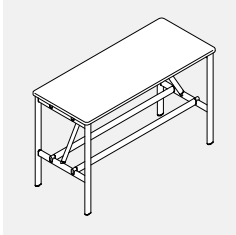

For 30" deep tables, 78" to 96" wide

- Bar Height Collaboration Tables on levelers consist of two leg assemblies, worksurface support beam(s), footrest(s) and one worksurface with a small 1.5" radius at each corner.
- Surface available in LP - Low Pressure or HP - High Pressure laminates.
- Legs are painted extruded aluminum. Levelers have 1" adjustment for leveling.
- Cutouts for power modules are limited to specific sizes/configurations, please see Grommet Location Chart.
- Tables 18" and 24" deep feature one worksurface support beam and one footrest.
- Tables 30" deep feature two worksurface support beams and two footrests.
- Tables 30" deep and 78" wide and greater include a reinforcement cantilever for added stability.

PRODUCT CODE	PRICE		SIZE/INCHES			WEIGHT LBS	VOL FT <sup>3</sup>
	LP	HP	H	W	D		
SCTBSL1836	1378	1449	42	36	18	52.58	2.33
SCTBSL1842	1470	1553	42	42	18	56.79	2.52
SCTBSL1848	1652	1746	42	48	18	63.90	2.71
SCTBSL1854	1677	1784	42	54	18	68.11	2.90
SCTBSL1860	1747	1865	42	60	18	72.31	3.08
SCTBSL1866	1772	1902	42	66	18	76.52	3.27
SCTBSL1872	1871	2013	42	72	18	80.72	3.46
SCTBSL1878	1897	2050	42	78	18	84.93	3.65
SCTBSL1884	1922	2088	42	84	18	89.13	3.83
SCTBSL1890	2095	2272	42	90	18	93.34	4.02
SCTBSL1896	2121	2310	42	96	18	97.55	4.21
SCTBSL2436	1471	1566	42	36	24	70.28	3.11
SCTBSL2442	1569	1679	42	42	24	77.02	3.36
SCTBSL2448	1757	1883	42	48	24	86.68	3.61
SCTBSL2454	1789	1930	42	54	24	93.43	3.86
SCTBSL2460	1864	2022	42	60	24	100.18	4.11
SCTBSL2466	1896	2069	42	66	24	106.93	4.36
SCTBSL2472	2001	2190	42	72	24	113.68	4.61
SCTBSL2478	2033	2237	42	78	24	120.43	4.86
SCTBSL2484	2064	2285	42	84	24	127.18	5.11
SCTBSL2490	2243	2479	42	90	24	133.93	5.36
SCTBSL2496	2275	2527	42	96	24	140.67	5.61
SCTBSL3036	1818	1936	42	36	30	88.53	3.89
SCTBSL3042	1988	2126	42	42	30	97.89	4.20
SCTBSL3048	2182	2340	42	48	30	110.14	4.51
SCTBSL3054	2220	2397	42	54	30	117.05	4.83
SCTBSL3060	2346	2543	42	60	30	126.41	5.14
SCTBSL3066	2384	2600	42	66	30	135.76	5.45
SCTBSL3072	2569	2805	42	72	30	145.11	5.76
SCTBSL3078	2752	3008	42	78	30	159.35	6.08
SCTBSL3084	2789	3065	42	84	30	168.71	6.70
SCTBSL3090	3122	3417	42	90	30	178.06	6.39
SCTBSL3096	3160	3474	42	96	30	187.41	7.01

**SCTSWSL • Workshop Table, 29" Work Height, Small Radius, Levelers**

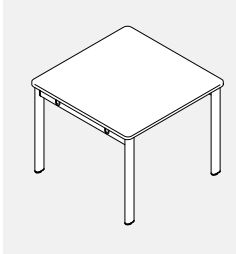

- Work Height Workshop Tables on levelers consist of two leg assemblies, two worksurface support beams and a one worksurface with a small 1.5" radius at each corner.
- Surface available in LP - Low Pressure or HP - High Pressure laminates.
- Legs are painted extruded aluminum. Levelers have 1" adjustment for leveling.
- Cutouts for power modules are limited to specific sizes/configurations, please see Grommet Location Chart.

PRODUCT CODE	PRICE		SIZE/INCHES			WEIGHT LBS	VOL FT <sup>3</sup>
	LP	HP	H	W	D		
SCTSWSL3636	1235	1377	29	36	36	79.31	4.67
SCTSWSL3642	1390	1555	29	42	36	88.83	5.04
SCTSWSL3648	1567	1756	29	48	36	101.24	5.42
SCTSWSL3654	1611	1824	29	54	36	110.76	5.79
SCTSWSL3660	1699	1935	29	60	36	120.27	6.17
SCTSWSL4242	1416	1609	29	42	42	99.72	5.88
SCTSWSL4248	1644	1865	29	48	42	113.52	6.32
SCTSWSL4254	1694	1942	29	54	42	124.41	6.76
SCTSWSL4260	1788	2064	29	60	42	135.31	7.19
SCTSWSL4848	1730	1982	29	48	48	125.80	7.22
SCTSWSL4854	1786	2069	29	54	48	138.07	7.72
SCTSWSL4860	1886	2201	29	60	48	150.35	8.22

**SCTSWSC • Workshop Table, 29" Work Height, Small Radius, Casters**

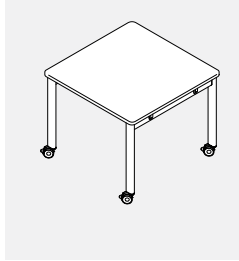

- Work Height Workshop Tables on casters consist of two leg assemblies, two worksurface support beams and a one worksurface with a small 1.5" radius at each corner.
- Surface available in LP - Low Pressure or HP - High Pressure laminates.
- Legs are painted extruded aluminum. Casters are lockable, in a choice of two finishes.
- Cutouts for power modules are limited to specific sizes/configurations, please see Grommet Location Chart.

PRODUCT CODE	PRICE		SIZE/INCHES			WEIGHT LBS	VOL FT <sup>3</sup>
	LP	HP	H	W	D		
SCTSWSC3636	1451	1593	29	36	36	79.40	4.67
SCTSWSC3642	1561	1727	29	42	36	88.92	5.04
SCTSWSC3648	1739	1928	29	48	36	101.33	5.42
SCTSWSC3654	1783	1996	29	54	36	110.85	5.79
SCTSWSC3660	1871	2107	29	60	36	120.36	6.17
SCTSWSC4242	1632	1825	29	42	42	99.81	5.88
SCTSWSC4248	1816	2037	29	48	42	113.61	6.32
SCTSWSC4254	1866	1942	29	54	42	124.50	6.76
SCTSWSC4260	1960	2236	29	60	42	135.40	7.19
SCTSWSC4848	1902	2154	29	48	48	125.89	7.22
SCTSWSC4854	1958	2241	29	54	48	138.16	7.72
SCTSWSC4860	2058	2373	29	60	48	150.44	8.22

**SCTSWSX • Workshop Table, 29" Work Height, Small Radius, Casters/Levelers**

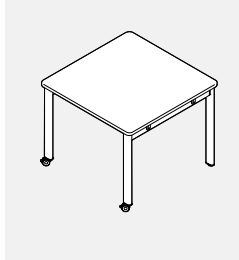

- Work Height Workshop Tables consist of one leg assembly with casters, one leg assembly with levelers, two worksurface support beams and a one worksurface with a small 1.5" radius at each corner.
- Surface available in LP - Low Pressure or HP - High Pressure laminates.
- Legs are painted extruded aluminum. Levelers have 1" adjustment for leveling. Casters are lockable, in a choice of 2 finishes.
- Cutouts for power modules are limited to specific sizes/configurations, please see Grommet Location Chart.

PRODUCT CODE	PRICE		SIZE/INCHES			WEIGHT LBS	VOL FT <sup>3</sup>
	LP	HP	H	W	D		
SCTSWSX3636	1343	1485	29	36	36	79.36	4.67
SCTSWSX3642	1453	1619	29	42	36	88.87	5.04
SCTSWSX3648	1653	1842	29	48	36	101.29	5.42
SCTSWSX3654	1697	1910	29	54	36	110.80	5.79
SCTSWSX3660	1785	2021	29	60	36	120.31	6.17
SCTSWSX4242	1524	1717	29	42	42	99.77	5.88
SCTSWSX4248	1730	1951	29	48	42	113.56	6.32
SCTSWSX4254	1780	2028	29	54	42	124.46	6.76
SCTSWSX4260	1874	2150	29	60	42	135.36	7.19
SCTSWSX4848	1816	2068	29	48	48	125.71	7.22
SCTSWSX4854	1872	2155	29	54	48	137.99	7.72
SCTSWSX4860	1972	2287	29	60	48	150.27	8.22

**SCTLWSL • Large Collaboration Table, 29" Work Height, Small Radius, Levelers**

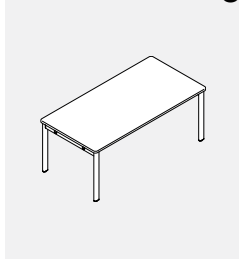

- Large Work Height Collaboration Tables on levelers consist of two leg assemblies, two worksurface support beams and a one worksurface with a small 1.5" radius at each corner.
- Surface available in LP - Low Pressure or HP - High Pressure laminates.
- Legs are painted extruded aluminum. Levelers have 1" adjustment for leveling.
- Cutouts for power modules are limited to specific sizes/configurations, please see Grommet Location Chart.

PRODUCT CODE	PRICE		SIZE/INCHES			WEIGHT LBS	VOL FT <sup>3</sup>
	LP	HP	H	W	D		
SCTLWSL3666	1743	2003	29	66	36	129.78	6.54
SCTLWSL3672	1860	2144	29	72	36	139.30	6.92
SCTLWSL3678	1922	2229	29	78	36	148.81	7.29
SCTLWSL3684	1966	2297	29	84	36	158.32	7.67
SCTLWSL3690	2157	2512	29	90	36	167.84	8.04
SCTLWSL3696	2201	2579	29	96	36	177.35	8.42
SCTLWSL4266	1838	2141	29	66	42	146.21	7.63
SCTLWSL4272	1962	2293	29	72	42	127.10	8.07
SCTLWSL4278	2030	2388	29	78	42	168.00	8.51
SCTLWSL4284	2080	2466	29	84	42	178.89	8.94
SCTLWSL4290	2277	2690	29	90	42	189.79	9.38
SCTLWSL4296	2327	2768	29	96	42	200.68	9.82
SCTLWSL4866	1942	2288	29	66	48	162.63	8.72
SCTLWSL4872	2072	2450	29	72	48	174.91	9.22
SCTLWSL4878	2146	2555	29	78	48	187.18	9.72
SCTLWSL4884	2202	2643	29	84	48	199.46	10.22
SCTLWSL4890	2405	2878	29	90	48	211.74	10.72
SCTLWSL4896	2461	2965	29	96	48	224.01	11.22

**SCTLWLL • Large Collaboration Table, 29" Work Height, Large Radius, Levelers**

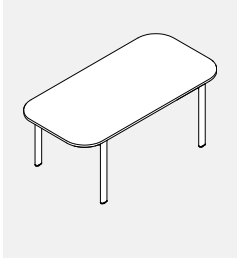

- Large Work Height Collaboration Tables on levelers consist of two leg assemblies, two worksurface support beams and a one worksurface with a large 9" radius at each corner with 10.5" overhang on each end.
- Surface available in LP - Low Pressure or HP - High Pressure laminates.
- Legs are painted extruded aluminum. Levelers have 1" adjustment for leveling.
- Cutouts for power modules are limited to specific sizes/configurations, please see Grommet Location Chart.
- Note: Large radius tables are not compatible with SCTAMxx and SCTAMTx Media Units.

PRODUCT CODE	PRICE		SIZE/INCHES			WEIGHT LBS	VOL FT <sup>3</sup>
	LP	HP	H	W	D		
SCTLWLL3666	1699	1958	29	66	36	123.52	6.54
SCTLWLL3672	1742	2026	29	72	36	133.03	6.92
SCTLWLL3678	1830	2137	29	78	36	142.55	7.29
SCTLWLL3684	1874	2205	29	84	36	152.06	7.67
SCTLWLL3690	1992	2346	29	90	36	161.57	8.04
SCTLWLL3696	2054	2431	29	96	36	171.09	8.42
SCTLWLL4266	1794	2097	29	66	42	139.94	7.63
SCTLWLL4272	1844	2175	29	72	42	150.84	8.07
SCTLWLL4278	1938	2296	29	78	42	161.73	8.51
SCTLWLL4284	1988	2374	29	84	42	172.63	8.94
SCTLWLL4290	2111	2525	29	90	42	183.52	9.38
SCTLWLL4296	2158	2599	29	96	42	194.42	9.82
SCTLWLL4866	1898	2244	29	66	48	156.37	8.72
SCTLWLL4872	1954	2332	29	72	48	168.64	9.22
SCTLWLL4878	2054	2463	29	78	48	180.92	9.72
SCTLWLL4884	2110	2551	29	84	48	193.20	10.22
SCTLWLL4890	2240	2712	29	90	48	205.48	10.72
SCTLWLL4896	2314	2818	29	96	48	217.75	11.22

**SCTLWSC • Large Collaboration Table, 29" Work Height, Small Radius, Casters**

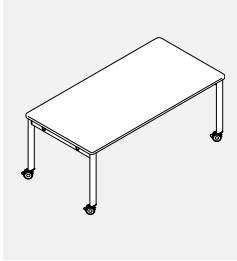

- Large Work Height Collaboration Tables on casters consist of two leg assemblies, two worksurface support beams and a one worksurface with a small 1.5" radius at each corner.
- Surface available in LP - Low Pressure or HP - High Pressure laminates.
- Legs are painted extruded aluminum. Casters are lockable, in a choice of two finishes.
- Cutouts for power modules are limited to specific sizes/configurations, please see Grommet Location Chart.

PRODUCT CODE	PRICE		SIZE/INCHES			WEIGHT LBS	VOL FT <sup>3</sup>
	LP	HP	H	W	D		
SCTLWSC3666	1915	2175	29	66	36	129.87	6.54
SCTLWSC3672	2032	2316	29	72	36	139.39	6.92
SCTLWSC3678	2094	2401	29	78	36	148.90	7.29
SCTLWSC3684	2138	2469	29	84	36	158.41	7.67
SCTLWSC3690	2329	2683	29	90	36	167.93	8.04
SCTLWSC3696	2373	2751	29	96	36	177.44	8.42
SCTLWSC4266	2010	2313	29	66	42	146.30	7.63
SCTLWSC4272	2134	2464	29	72	42	157.19	8.07
SCTLWSC4278	2202	2560	29	78	42	168.09	8.51
SCTLWSC4284	2252	2637	29	84	42	178.98	8.94
SCTLWSC4290	2449	2862	29	90	42	189.88	9.38
SCTLWSC4296	2306	2747	29	96	42	200.77	9.82
SCTLWSC4866	2114	2460	29	66	48	162.72	8.72
SCTLWSC4872	2244	2621	29	72	48	175.00	9.22
SCTLWSC4878	2318	2727	29	78	48	187.27	9.72
SCTLWSC4884	2374	2815	29	84	48	199.55	10.22
SCTLWSC4890	2577	3050	29	90	48	211.83	10.72
SCTLWSC4896	2633	3137	29	96	48	224.10	11.22

**SCTLWLC • Large Collaboration Table, 29" Work Height, Large Radius, Casters**

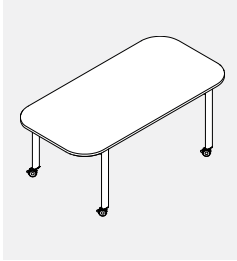

- Large Work Height Collaboration Tables on casters consist of two leg assemblies, two worksurface support beams and a one worksurface with a large 9" radius at each corner with 10.5" overhang on each end.
- Surface available in LP - Low Pressure or HP - High Pressure laminates.
- Legs are painted extruded aluminum. Casters are lockable, in a choice of two finishes.
- Cutouts for power modules are limited to specific sizes/configurations, please see Grommet Location Chart.
- Note: Large radius tables are not compatible with SCTAMxx and SCTAMTx Media Units.

PRODUCT CODE	PRICE		SIZE/INCHES			WEIGHT LBS	VOL FT <sup>3</sup>
	LP	HP	H	W	D		
SCTLWLC3666	1871	2130	29	66	36	123.61	6.54
SCTLWLC3672	1914	2198	29	72	36	133.12	6.92
SCTLWLC3678	2002	2309	29	78	36	142.64	7.29
SCTLWLC3684	2046	2377	29	84	36	152.15	7.67
SCTLWLC3690	2163	2518	29	90	36	161.66	8.04
SCTLWLC3696	2225	2603	29	96	36	171.18	8.42
SCTLWLC4266	1966	2269	29	66	42	140.03	7.63
SCTLWLC4272	2016	2346	29	72	42	150.93	8.07
SCTLWLC4278	2110	2468	29	78	42	161.82	8.51
SCTLWLC4284	2160	2545	29	84	42	172.72	8.94
SCTLWLC4290	2283	2697	29	90	42	183.62	9.38
SCTLWLC4296	2351	2792	29	96	42	194.51	9.82
SCTLWLC4866	2070	2416	29	66	48	156.46	8.72
SCTLWLC4872	2126	2503	29	72	48	168.73	9.22
SCTLWLC4878	2226	2635	29	78	48	181.01	9.72
SCTLWLC4884	2282	2723	29	84	48	193.29	10.22
SCTLWLC4890	2411	2884	29	90	48	205.57	10.72
SCTLWLC4896	2486	2989	29	96	48	217.84	11.22



**SCTSCSL • Workshop Table, 36" Café Height, Small Radius, Levelers**



- Café Height Workshop Tables on levelers consist of two leg assemblies, two worksurface support beams, dual footrests and a one worksurface with a small 1.5" radius at each corner.
- Surface available in LP - Low Pressure or HP - High Pressure laminates.
- Legs are painted extruded aluminum. Levelers have 1" adjustment for leveling.
- Cutouts for power modules are limited to specific sizes/configurations, please see Grommet Location Chart.

PRODUCT CODE	PRICE		SIZE/INCHES			WEIGHT LBS	VOL FT³
	LP	HP	H	W	D		
SCTSCSL3636	1817	1959	36	36	36	96.82	5.67
SCTSCSL3642	1993	2159	36	42	36	107.56	6.21
SCTSCSL3648	2193	2382	36	48	36	121.20	6.75
SCTSCSL3654	2237	2450	36	54	36	131.93	7.29
SCTSCSL3660	2369	2605	36	60	36	142.67	7.83
SCTSCSL4242	2043	2236	36	42	42	119.68	7.05
SCTSCSL4248	2291	2512	36	48	42	134.70	7.65
SCTSCSL4254	2341	2589	36	54	42	146.81	8.26
SCTSCSL4260	2480	2755	36	60	42	158.93	8.86
SCTSCSL4848	2406	2658	36	48	48	148.20	8.56
SCTSCSL4854	2462	2746	36	54	48	161.70	9.22
SCTSCSL4860	2607	2922	36	60	48	175.20	9.89

**SCTSCSC • Workshop Table, 36" Café Height, Small Radius, Casters**



- Café Height Workshop Tables on casters consist of two leg assemblies, two worksurface support beams, dual footrests and a one worksurface with a small 1.5" radius at each corner.
- Surface available in LP - Low Pressure or HP - High Pressure laminates.
- Legs are painted extruded aluminum. Casters are lockable, in a choice of two finishes.
- Cutouts for power modules are limited to specific sizes/configurations, please see Grommet Location Chart.

PRODUCT CODE	PRICE		SIZE/INCHES			WEIGHT LBS	VOL FT³
	LP	HP	H	W	D		
SCTSCSC3636	2013	2155	36	36	36	96.66	5.67
SCTSCSC3642	2190	2355	36	42	36	107.39	6.21
SCTSCSC3648	2390	2579	36	48	36	121.03	6.75
SCTSCSC3654	2433	2646	36	54	36	131.77	7.29
SCTSCSC3660	2566	2802	36	60	36	142.50	7.83
SCTSCSC4242	2282	2475	36	42	42	119.51	7.05
SCTSCSC4248	2488	2708	36	48	42	134.53	7.65
SCTSCSC4254	2538	2786	36	54	42	146.65	8.26
SCTSCSC4296	2676	2952	36	60	42	158.77	8.86
SCTSCSC4848	2603	2855	36	48	48	148.03	8.56
SCTSCSC4854	2659	2942	36	54	48	161.53	9.22
SCTSCSC4860	2803	3118	36	60	48	175.03	9.89

**SCTLCSL • Large Collaboration Table, 36" Café Height, Small Radius, Levelers**

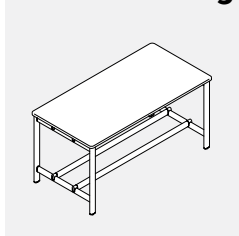

For 66" and 72" wide tables



For 78" to 96" wide tables

- Large Café Height Collaboration Tables on levelers consist of two leg assemblies, two worksurface support beams, dual footrests and a one worksurface with a small 1.5" radius at each corner.
- Surface available in LP - Low Pressure or HP - High Pressure laminates.
- Legs are painted extruded aluminum. Levelers have 1" adjustment for leveling.
- Cutouts for power modules are limited to specific sizes/configurations, please see Grommet Location Chart.
- Tables 78" wide and greater include a reinforcement cantilever for added stability.

PRODUCT CODE	PRICE		SIZE/INCHES			WEIGHT LBS	VOL FT³
	LP	HP	H	W	D		
SCTLCSL3666	2413	2673	36	66	36	153.40	8.38
SCTLCSL3672	2604	2888	36	72	36	164.14	8.92
SCTLCSL3678	2793	3100	36	78	36	177.32	9.46
SCTLCSL3684	2837	3168	36	84	36	188.05	10.00
SCTLCSL3690	3176	3530	36	90	36	198.79	10.54
SCTLCSL3696	3219	3597	36	96	36	209.52	11.08
SCTLCSL4266	2529	2832	36	66	42	171.05	9.47
SCTLCSL4272	2727	3057	36	72	42	183.17	10.07
SCTLCSL4278	2922	3280	36	78	42	197.73	10.67
SCTLCSL4284	2972	3358	36	84	42	209.84	11.28
SCTLCSL4290	3317	3730	36	90	42	221.96	11.88
SCTLCSL4296	3366	3807	36	96	42	234.08	12.49
SCTLCSL4866	2663	3009	36	66	48	188.69	10.56
SCTLCSL4872	2866	3244	36	72	48	202.19	11.22
SCTLCSL4878	3067	3477	36	78	48	218.14	11.89
SCTLCSL4884	3123	3564	36	84	48	231.63	12.56
SCTLCSL4890	3474	3947	36	90	48	245.13	13.22
SCTLCSL4896	3530	4034	36	96	48	258.63	13.89

**SCTLCLL • Large Collaboration Table, 36" Café Height, Large Radius, Levelers**



For 66" to 90" wide tables

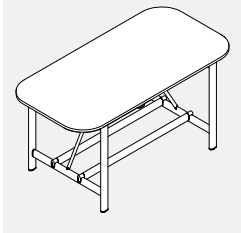

For 96" wide tables

- Large Café Height Collaboration Tables on levelers consist of two leg assemblies, two worksurface support beams and a one worksurface with a large 9" radius at each corner with 10.5" overhang on each end.
- Surface available in LP - Low Pressure or HP - High Pressure laminates.
- Legs are painted extruded aluminum. Levelers have 1" adjustment for leveling.
- Cutouts for power modules are limited to specific sizes/configurations, please see Grommet Location Chart.
- Tables 78" wide and greater include a reinforcement cantilever for added stability.
- Note: Large radius tables are not compatible with SCTAMxx and SCTAMTx Media Units.

PRODUCT CODE	PRICE		SIZE/INCHES			WEIGHT LBS	VOL FT <sup>3</sup>
	LP	HP	H	W	D		
SCTLCLL3666	2324	2584	36	66	36	143.48	8.38
SCTLCLL3672	2368	2652	36	72	36	154.21	8.92
SCTLCLL3678	2500	2807	36	78	36	164.95	9.46
SCTLCLL3684	2544	2875	36	84	36	175.68	10.00
SCTLCLL3690	2735	3090	36	90	36	186.42	10.54
SCTLCLL3696	2924	3302	36	96	36	199.60	11.08
SCTLCLL4266	2441	2744	36	66	42	161.12	9.47
SCTLCLL4272	2491	2821	36	72	42	173.24	10.07
SCTLCLL4278	2629	2987	36	78	42	185.36	10.67
SCTLCLL4284	2679	3065	36	84	42	197.47	11.28
SCTLCLL4290	2876	3290	36	90	42	209.59	11.88
SCTLCLL4296	2724	3165	36	96	42	224.15	12.49
SCTLCLL4866	2574	2921	36	66	48	178.77	10.56
SCTLCLL4872	2630	3008	36	72	48	192.27	11.22
SCTLCLL4878	2775	3184	36	78	48	205.77	11.89
SCTLCLL4884	2830	3271	36	84	48	219.26	12.56
SCTLCLL4890	3034	3506	36	90	48	232.76	13.22
SCTLCLL4896	3235	3739	36	96	48	248.71	13.89

**SCTLCSC • Large Collaboration Table, 36" Café Height, Small Radius, Casters**



For 66" to 90" wide tables



For 96" wide tables

- Large Café Height Collaboration Tables on casters consist of two leg assemblies, two worksurface support beams, dual footrests and a one worksurface with a small 1.5" radius at each corner.
- Surface available in LP - Low Pressure or HP - High Pressure laminates.
- Legs are painted extruded aluminum. Casters are lockable, in a choice of two finishes.
- Cutouts for power modules are limited to specific sizes/configurations, please see Grommet Location Chart.
- Tables 78" wide and greater include a reinforcement cantilever for added stability.

PRODUCT CODE	PRICE		SIZE/INCHES			WEIGHT LBS	VOL FT <sup>3</sup>
	LP	HP	H	W	D		
SCTLCSC3666	2609	2869	36	66	36	153.24	8.38
SCTLCSC3672	2801	3084	36	72	36	163.97	8.92
SCTLCSC3678	2990	3297	36	78	36	177.15	9.46
SCTLCSC3684	3033	3364	36	84	36	187.89	10.00
SCTLCSC3690	3372	3726	36	90	36	198.62	10.54
SCTLCSC3696	3416	3794	36	96	36	209.36	11.08
SCTLCSC4266	2726	3029	36	66	42	170.88	9.47
SCTLCSC4272	2923	3254	36	72	42	183.00	10.07
SCTLCSC4278	3118	3477	36	78	42	197.56	10.67
SCTLCSC4284	3168	3554	36	84	42	209.68	11.28
SCTLCSC4290	3513	3926	36	90	42	221.80	11.88
SCTLCSC4296	3563	4004	36	96	42	233.91	12.49
SCTLCSC4866	2859	3205	36	66	48	188.53	10.56
SCTLCSC4872	3062	3440	36	72	48	202.03	11.22
SCTLCSC4878	3264	3673	36	78	48	217.97	11.89
SCTLCSC4884	3320	3761	36	84	48	231.47	12.56
SCTLCSC4890	3671	4143	36	90	48	244.97	13.22
SCTLCSC4896	3727	4231	36	96	48	258.47	13.89

**SCTLCLC • Large Collaboration Table, 36" Café Height, Large Radius, Casters**



For 66" to 90" wide tables



For 96" wide tables

- Large Café Height Collaboration Tables on casters consist of two leg assemblies, two worksurface support beams and a one worksurface with a large 9" radius at each corner with 10.5" overhang on each end.
- Surface available in LP - Low Pressure or HP - High Pressure laminates.
- Legs are painted extruded aluminum. Casters are lockable, in a choice of two finishes.
- Cutouts for power modules are limited to specific sizes/configurations, please see Grommet Location Chart.
- Tables 78" wide and greater include a reinforcement cantilever for added stability.
- Note: Large radius tables are not compatible with SCTAMxx and SCTAMTx Media Units.

PRODUCT CODE	PRICE		SIZE/INCHES			WEIGHT LBS	VOL FT <sup>3</sup>
	LP	HP	H	W	D		
SCTLCLC3666	2521	2781	36	66	36	143.31	8.38
SCTLCLC3672	2565	2848	36	72	36	154.05	8.92
SCTLCLC3678	2697	3004	36	78	36	164.78	9.46
SCTLCLC3684	2741	3071	36	84	36	175.52	10.00
SCTLCLC3690	2932	3286	36	90	36	186.25	10.54
SCTLCLC3696	3121	3499	36	96	36	199.43	11.08
SCTLCLC4266	2637	2940	36	66	42	160.96	9.47
SCTLCLC4272	2687	3018	36	72	42	173.07	10.07
SCTLCLC4278	2825	3184	36	78	42	185.19	10.67
SCTLCLC4284	2875	3261	36	84	42	197.31	11.28
SCTLCLC4290	3073	3486	36	90	42	209.43	11.88
SCTLCLC4296	3268	3709	36	96	42	223.98	12.49
SCTLCLC4866	2771	3117	42	66	48	178.60	10.56
SCTLCLC4872	2826	3204	42	72	48	192.10	11.22
SCTLCLC4878	2971	3380	42	78	48	205.60	11.89
SCTLCLC4884	3027	3468	42	84	48	219.10	12.56
SCTLCLC4890	3230	3703	42	90	48	232.60	13.22
SCTLCLC4896	3432	3936	42	96	48	248.54	13.89

**SCTSBSL • Workshop Table, 42" Bar Height, Small Radius, Levelers**



- Bar Height Workshop Tables on levelers consist of two leg assemblies, two worksurface support beams, dual footrests and a one worksurface with a small 1.5" radius at each corner.
- Surface available in LP - Low Pressure or HP - High Pressure laminates.
- Legs are painted extruded aluminum. Levelers have 1" adjustment for leveling.
- Cutouts for power modules are limited to specific sizes/configurations, please see Grommet Location Chart.

PRODUCT CODE	PRICE		SIZE/INCHES			WEIGHT LBS	VOL FT <sup>3</sup>
	LP	HP	H	W	D		
SCTSBSL3636	1918	2060	42	36	36	99.27	5.67
SCTSBSL3642	2094	2260	42	42	36	110.00	6.21
SCTSBSL3648	2294	2483	42	48	36	123.64	6.75
SCTSBSL3654	2338	2551	42	54	36	134.38	7.29
SCTSBSL3660	2470	2707	42	60	36	145.11	7.83
SCTSBSL4242	2186	2379	42	42	42	122.12	7.05
SCTSBSL4248	2392	2613	42	48	42	137.14	7.65
SCTSBSL4254	2442	2690	42	54	42	149.26	8.26
SCTSBSL4260	2581	2856	42	60	42	161.38	8.86
SCTSBSL4848	2507	2759	42	48	48	150.64	8.56
SCTSBSL4854	2563	2847	42	54	48	164.14	9.22
SCTSBSL4860	2708	3023	42	60	48	177.64	9.89

**SCTSBSC • Workshop Table, 42" Bar Height, Small Radius, Casters**

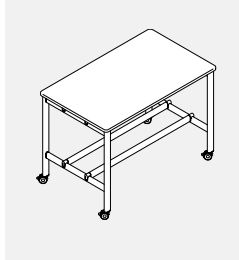

- Bar Height Workshop Tables on casters consist of two leg assemblies, two worksurface support beams, dual footrests and a one worksurface with a small 1.5" radius at each corner.
- Surface available in LP - Low Pressure or HP - High Pressure laminates.
- Legs are painted extruded aluminum. Levelers have 1" adjustment for leveling.
- Cutouts for power modules are limited to specific sizes/configurations, please see Grommet Location Chart.

PRODUCT CODE	PRICE		SIZE/INCHES			WEIGHT LBS	VOL FT <sup>3</sup>
	LP	HP	H	W	D		
SCTSBSC3636	2055	2197	42	36	36	99.10	5.67
SCTSBSC3642	2232	2397	42	42	36	109.84	6.21
SCTSBSC3648	2432	2621	42	48	36	123.48	6.75
SCTSBSC3654	2476	2688	42	54	36	134.21	7.29
SCTSBSC3660	2608	2844	42	60	36	144.95	7.83
SCTSBSC4242	2324	2517	42	42	42	121.95	7.05
SCTSBSC4248	2530	2750	42	48	42	136.98	7.65
SCTSBSC4254	2580	2828	42	54	42	149.09	8.26
SCTSBSC4296	2718	2994	42	60	42	161.21	8.86
SCTSBSC4848	2645	2897	42	48	48	150.47	8.56
SCTSBSC4854	2701	2984	42	54	48	163.97	9.22
SCTSBSC4860	2845	3160	42	60	48	177.47	9.89

**SCTLBSL • Large Collaboration Table, 42" Bar Height, Small Radius, Levelers**



For 66" and 72" wide tables

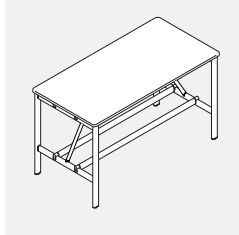

For 78" to 96" wide tables

- Large Bar Height Collaboration Tables on levelers consist of two leg assemblies, two worksurface support beams, dual footrests and a one worksurface with a small 1.5" radius at each corner.
- Surface available in LP - Low Pressure or HP - High Pressure laminates.
- Legs are painted extruded aluminum. Levelers have 1" adjustment for leveling.
- Cutouts for power modules are limited to specific sizes/configurations, please see Grommet Location Chart.
- Tables 78" wide and greater include a reinforcement cantilever for added stability.

PRODUCT CODE	PRICE		SIZE/INCHES			WEIGHT LBS	VOL FT <sup>3</sup>
	LP	HP	H	W	D		
SCTLBSL3666	2514	2774	42	66	36	155.85	8.38
SCTLBSL3672	2705	2989	42	72	36	166.58	8.92
SCTLBSL3678	2917	3224	42	78	36	179.76	9.46
SCTLBSL3684	2960	3291	42	84	36	190.50	10.00
SCTLBSL3690	3299	3653	42	90	36	201.23	10.54
SCTLBSL3696	3343	3721	42	96	36	211.97	11.08
SCTLBSL4266	2630	2934	42	66	42	173.49	9.47
SCTLBSL4272	2828	3158	42	72	42	185.61	10.07
SCTLBSL4278	3045	3403	42	78	42	200.17	10.67
SCTLBSL4284	3095	3481	42	84	42	212.29	11.28
SCTLBSL4290	3440	3853	42	90	42	224.41	11.88
SCTLBSL4296	3490	3931	42	96	42	236.52	12.49
SCTLBSL4866	2764	3110	42	66	48	191.14	10.56
SCTLBSL4872	2967	3345	42	72	48	204.64	11.22
SCTLBSL4878	3191	3600	42	78	48	220.58	11.89
SCTLBSL4884	3247	3687	42	84	48	234.08	12.56
SCTLBSL4890	3597	4070	42	90	48	247.58	13.22
SCTLBSL4896	3653	4157	42	96	48	261.08	13.89

**SCTLBLL • Large Collaboration Table, 42" Bar Height, Large Radius, Levelers**

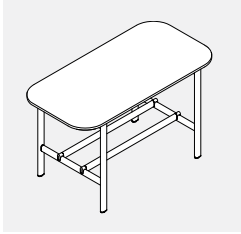

For 66" to 90" wide tables

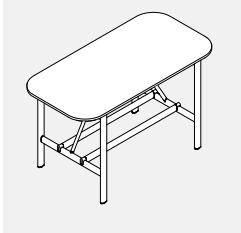

For 96" wide tables

- Large Bar Height Collaboration Tables on levelers consist of two leg assemblies, two worksurface support beams and a one worksurface with a large 9" radius at each corner with 10.5" overhang on each end.
- Surface available in LP - Low Pressure or HP - High Pressure laminates.
- Legs are painted extruded aluminum. Levelers have 1" adjustment for leveling.
- Cutouts for power modules are limited to specific sizes/configurations, please see Grommet Location Chart.
- Tables 78" wide and greater include a reinforcement cantilever for added stability.
- Note: Large radius tables are not compatible with SCTAMxx and SCTAMTx Media Units.

PRODUCT CODE	PRICE		SIZE/INCHES			D	WEIGHT LBS	VOL FT³
	LP	HP	H	W	W			
SCTLBLL3666	2426	2685	42	66	36	145.92	8.38	
SCTLBLL3672	2469	2753	42	72	36	156.66	8.92	
SCTLBLL3678	2729	3036	42	78	36	167.39	9.46	
SCTLBLL3684	2772	2976	42	84	36	178.13	10.00	
SCTLBLL3690	2964	3191	42	90	36	188.86	10.54	
SCTLBLL3696	3026	3403	42	96	36	202.04	11.08	
SCTLBLL4266	2542	2845	42	66	42	163.57	9.47	
SCTLBLL4272	2592	2922	42	72	42	175.68	10.07	
SCTLBLL4278	2857	3088	42	78	42	187.80	10.67	
SCTLBLL4284	2907	3166	42	84	42	199.92	11.28	
SCTLBLL4290	3104	3391	42	90	42	212.04	11.88	
SCTLBLL4296	3173	3613	42	96	42	226.60	12.49	
SCTLBLL4866	2675	3022	42	66	48	181.21	10.56	
SCTLBLL4872	2731	3109	42	72	48	194.71	11.22	
SCTLBLL4878	3003	3285	42	78	48	208.21	11.89	
SCTLBLL4884	3059	3372	42	84	48	221.71	12.56	
SCTLBLL4890	3262	3607	42	90	48	235.21	13.22	
SCTLBLL4896	3336	3840	42	96	48	251.15	13.89	

**SCTLBSC • Large Collaboration Table, 42" Bar Height, Small Radius, Casters**



For 66" and 72" wide tables

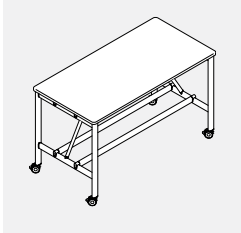

For 78" to 96" wide tables

- Large Bar Height Collaboration Tables on casters consist of two leg assemblies, two worksurface support beams and a one worksurface with a small 1.5" radius at each corner.
- Surface available in LP - Low Pressure or HP - High Pressure laminates.
- Legs are painted extruded aluminum. Casters are lockable, in a choice of two finishes.
- Cutouts for power modules are limited to specific sizes/configurations, please see Grommet Location Chart.
- Tables 78" wide and greater include a reinforcement cantilever for added stability.

PRODUCT CODE	PRICE		SIZE/INCHES			D	WEIGHT LBS	VOL FT³
	LP	HP	H	W	W			
SCTLBSC3666	2652	2911	42	66	36	155.68	8.38	
SCTLBSC3672	2843	3126	42	72	36	166.42	8.92	
SCTLBSC3678	3054	3361	42	78	36	179.60	9.46	
SCTLBSC3684	3098	3428	42	84	36	190.33	10.00	
SCTLBSC3690	3436	3791	42	90	36	201.07	10.54	
SCTLBSC3696	3480	3858	42	96	36	211.80	11.08	
SCTLBSC4266	2768	3071	42	66	42	173.33	9.47	
SCTLBSC4272	2965	3296	42	72	42	185.45	10.07	
SCTLBSC4278	3183	3541	42	78	42	200.00	10.67	
SCTLBSC4284	3232	3618	42	84	42	212.12	11.28	
SCTLBSC4290	3577	3991	42	90	42	224.24	11.88	
SCTLBSC4296	3627	4068	42	96	42	236.36	12.49	
SCTLBSC4866	2901	3248	42	66	48	190.97	10.56	
SCTLBSC4872	3105	3483	42	72	48	204.47	11.22	
SCTLBSC4878	3328	3737	42	78	48	220.41	11.89	
SCTLBSC4884	3384	3825	42	84	48	233.91	12.56	
SCTLBSC4890	3735	4207	42	90	48	247.41	13.22	
SCTLBSC4896	3791	4295	42	96	48	260.91	13.89	

**SCTLBLC • Large Collaboration Table, 42" Bar Height, Large Radius, Casters**



For 66" to 90" wide tables

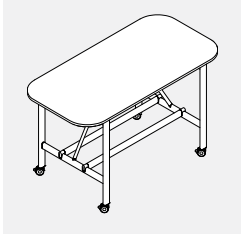

For 96" wide tables

- Large Bar Height Collaboration Tables on casters consist of two leg assemblies, two worksurface support beams and a one worksurface with a large 9" radius at each corner with 10.5" overhang on each end.
- Surface available in LP - Low Pressure or HP - High Pressure laminates.
- Legs are painted extruded aluminum. Casters are lockable, in a choice of two finishes.
- Cutouts for power modules are limited to specific sizes/configurations, please see Grommet Location Chart.
- Tables 96" wide include a reinforcement cantilever for added stability.
- Note: Large radius tables are not compatible with SCTAMxx and SCTAMTx Media Units.

PRODUCT CODE	PRICE		SIZE/INCHES			D	WEIGHT LBS	VOL FT³
	LP	HP	H	W	W			
SCTLBLC3666	2563	2823	42	66	36	145.75	8.38	
SCTLBLC3672	2607	2890	42	72	36	156.49	8.92	
SCTLBLC3678	2739	3046	42	78	36	167.23	9.46	
SCTLBLC3684	2783	3113	42	84	36	177.96	10.00	
SCTLBLC3690	2974	3328	42	90	36	188.70	10.54	
SCTLBLC3696	3163	3541	42	96	36	201.87	11.08	
SCTLBLC4266	2679	2983	42	66	42	163.40	9.47	
SCTLBLC4272	2729	3060	42	72	42	175.52	10.07	
SCTLBLC4278	2868	3226	42	78	42	187.63	10.67	
SCTLBLC4284	2917	3303	42	84	42	199.75	11.28	
SCTLBLC4290	3115	3528	42	90	42	211.87	11.88	
SCTLBLC4296	3310	3751	42	96	42	226.43	12.49	
SCTLBLC4866	2813	3159	42	66	48	181.04	10.56	
SCTLBLC4872	2869	3247	42	72	48	197.54	11.22	
SCTLBLC4878	3013	3422	42	78	48	208.04	11.89	
SCTLBLC4884	3069	3510	42	84	48	221.54	12.56	
SCTLBLC4890	3272	3745	42	90	48	235.04	13.22	
SCTLBLC4896	3474	3978	42	96	48	250.98	13.89	

**SCTAM • Collaboration Table Media Unit**

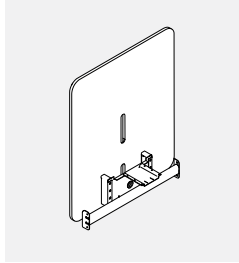

- Collaboration Table Media Unit can be affixed to all small radius tables of the same nominal width. User side is thermally fused laminate to accept TV mounts. Side facing away from users features a tackable PET panel affixed to the thermally fused laminate with a 0.5" inset.
- Surface available in LP - Low Pressure Laminate.
- Felt backer available in all standard finishes.
- Brackets and reinforcement bar is painted metal.
- TV mount not included.
- Units 36" wide can accept TV's up to 40", not exceeding 50 lbs.
- Units 42" wide can accept TV's up to 43", not exceeding 50 lbs.
- Units 48" wide can accept TV's up to 55", not exceeding 50 lbs.

PRODUCT CODE	PRICE LP	SIZE/INCHES			WEIGHT VOL	
		H	W	D	LBS	FT <sup>3</sup>
SCTAM36	748	43	36	11.25	46.28	10.08
SCTAM42	767	43	42	11.25	52.50	11.76
SCTAM48	826	43	48	11.25	58.83	13.44

**SCTAMT • Collaboration Table Media Unit with TV Mount**

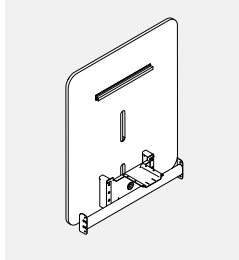

- Collaboration Table Media Unit with TV Mount can be affixed to all small radius tables of the same nominal width. User side is thermally fused laminate and includes a TV mount. Side facing away from users features a tackable PET panel affixed to the thermally fused laminate with a 0.5" inset.
- Surface available in LP - Low Pressure Laminate.
- Felt backer available in all standard finishes.
- Brackets and reinforcement bar is painted metal.
- Units 36" wide can accept TV's up to 40", not exceeding 50 lbs.
- Units 42" wide can accept TV's up to 43", not exceeding 50 lbs.
- Units 48" wide can accept TV's up to 55", not exceeding 50 lbs.

PRODUCT CODE	PRICE LP	SIZE/INCHES			WEIGHT VOL	
		H	W	D	LBS	FT <sup>3</sup>
SCTAMT36	942	43	36	11.25	47.58	10.08
SCTAMT42	961	43	42	11.25	53.80	11.76
SCTAMT48	1020	43	48	11.25	60.13	13.44

**SCTAL • Table Leg Cable Organizer**

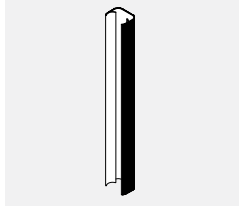

- Table Leg Cable organizer snaps on to any leg to manage wires vertically. Black only.

PRODUCT CODE	PRICE	SIZE/INCHES			WEIGHT VOL	
		H	W	D	LBS	FT <sup>3</sup>
SCTAL21	29	21	2.965	2.21	0.60	0.09
SCTAL23	33	23	2.965	2.21	0.60	0.09

**SCTAP • PET Felt Modesty Panel**

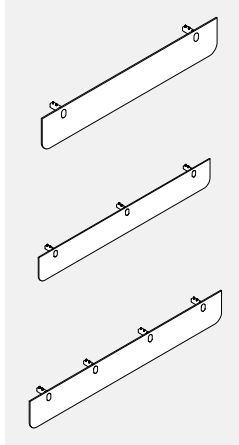

- PET Felt modesty panel with metal brackets for use on Core, Standard and Workshop tables.
- Modesty panels 36" to 54" include two brackets.
- Modesty panels 60" to 90" include three brackets.
- Modesty panels 96" include four brackets.
- Specify matching nominal width to table.
- PET Felt available in standard finishes.

PRODUCT CODE	PRICE	SIZE/INCHES			WEIGHT VOL	
		H	W	D	LBS	FT <sup>3</sup>
SCTAP36	75	11	33	4.75	1.78	1.00
SCTAP42	81	11	39	4.75	1.99	1.18
SCTAP48	81	11	45	4.75	2.14	1.36
SCTAP54	85	11	51	4.75	2.38	1.54
SCTAP60	114	11	57	4.75	2.53	1.72
SCTAP66	118	11	63	4.75	2.68	1.90
SCTAP72	122	11	69	4.75	2.87	2.09
SCTAP78	126	11	75	4.75	3.05	2.27
SCTAP84	137	11	81	4.75	3.23	2.45
SCTAP90	149	11	87	4.75	3.41	2.63
SCTAP96	162	11	93	4.75	3.59	2.81

**SCTAT • Wire Mesh Storage Tray**

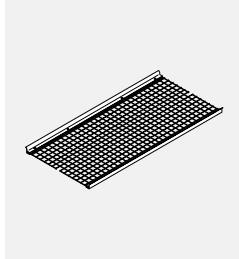

- Steel storage tray is attached between dual stretchers on tables 48"d x 48"w and larger.
- Specify matching nominal width to table.
- Cannot be combined with SCTAM/SCTAMT Media Units on tables on casters.
- Specify matching nominal width to table.

PRODUCT CODE	PRICE	SIZE/INCHES			WEIGHT VOL	
		H	W	D	LBS	FT <sup>3</sup>
SCTAT4848	204	1.6	42	22	7.85	0.98
SCTAT4854	229	1.6	48	22	8.97	1.10
SCTAT4860	260	1.6	54	22	10.09	1.22
SCTAT4866	294	1.6	60	22	11.19	1.34
SCTAT4872	392	1.6	66	22	12.29	1.47
SCTAT4878	403	1.6	72	22	13.40	1.59
SCTAT4884	417	1.6	78	22	14.52	1.71
SCTAT4890	481	1.6	84	22	15.62	1.83
SCTAT4896	495	1.6	90	22	16.72	1.96

**SCTAH • Table Mounted Bag Hook**



- Steel hook for use on Collaborative tables.
- Specify standard metal paint finish.
- Maximum capacity of 10 lbs.

PRODUCT CODE	PRICE	SIZE/INCHES			WEIGHT VOL	
		H	W	D	LBS	FT <sup>3</sup>
SCTAH	16	3.5	1.5	0.65	0.30	

**SCTAPE • Nik Edge/Clamp Mount Power Module**

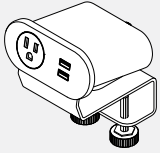

- Nik Edge/Clamp Mount Power Module in black with black receptacles, 10ft cord.
- Specify configuration, last letter of the code represents the following:
- A = 1 AC, 1 USB-A 1.5A charge port, 1 USB-A 2.4A quick charge port
- B = 2 AC
- C = 2 AC, 1 USB-A 1.5A charge port, 1 USB-A 2.4A quick charge port
- D = 1 AC, 1 USB-A 1.5A charge port, 1 USB-A 2.4A quick charge port, 1 60W USB-C charge port
- E = 3 AC

PRODUCT CODE	PRICE	SIZE/INCHES			WEIGHT VOL	
		H	W	D	LBS	FT <sup>3</sup>
SCTAPEA	516	3.7	6	2.10	4.00	
SCTAPEB	491	3.7	6	2.10	4.00	
SCTAPEA	569	3.7	6	2.10	4.00	
SCTAPED	672	3.7	6	2.10	4.00	
SCTAPEE	502	3.7	6	2.10	4.00	

**SCTAPS • Nik In-Surface Power Module**

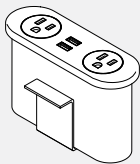

- Nik In-Surface Power Module in black with black receptacles, 10ft cord.
- Specify configuration, last letter of the code represents the following:
- C = 2 AC, 1 USB-A 1.5A charge port, 1 USB-A 2.4A quick charge port
- D = 1 AC, 1 USB-A 1.5A charge port, 1 USB-A 2.4A quick charge port, 1 60W USB-C charge port
- E = 3 AC

PRODUCT CODE	PRICE	SIZE/INCHES			WEIGHT VOL	
		H	W	D	LBS	FT <sup>3</sup>
SCTAPSC	578	3.7	6	2.10	4.00	0.03
SCTAPSD	718	3.7	6	2.10	4.00	0.03
SCTAPSE	509	3.7	6	2.10	4.00	0.03

**SCTAPB • Nik Below Surface Power Module**

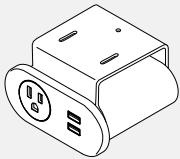

- Nik Below Surface Power Module in black with black receptacles, 10ft cord.
- Specify configuration, last letter of the code represents the following:
- A = 1 AC, 1 USB-A 1.5A charge port, 1 USB-A 2.4A quick charge port
- B = 2 AC
- C = 2 AC, 1 USB-A 1.5A charge port, 1 USB-A 2.4A quick charge port
- D = 1 AC, 1 USB-A 1.5A charge port, 1 USB-A 2.4A quick charge port, 1 60W USB-C charge port
- E = 3 AC

PRODUCT CODE	PRICE	SIZE/INCHES			WEIGHT VOL	
		H	W	D	LBS	FT <sup>3</sup>
SCTAPBA	562	3.7	6	2.10	4.00	0.03
SCTAPBB	512	3.7	6	2.10	4.00	0.03
SCTAPBC	596	3.7	6	2.10	4.00	0.03
SCTAPBD	741	3.7	6	2.10	4.00	0.03
SCTAPBE	524	3.7	6	2.10	4.00	0.03

**SCTAPPB • Below Surface Power Bar**

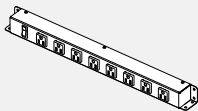

SCTAPPBS

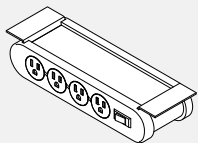

SCTAPPBD

- Below surface power bar is black only.
- Single (SCTAPPBS) includes 8 outlets on a single side.
- Double (SCTAPPBD) includes 4 outlets on each side of the bar. Built-in circuit breaker (shown).
- Cord length is 10".

PRODUCT CODE	PRICE	SIZE/INCHES			WEIGHT VOL	
		H	W	D	LBS	FT <sup>3</sup>
SCTAPPBS	436	1.95	21	1.95	2.70	0.06
SCTAPPBD	1069	2.3	10.6	4.00	4.00	0.05

**SCTAPT • Collaborative Spaces Power Tray**

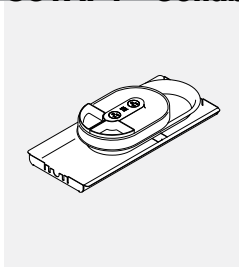

- Black plastic power tray with removable grey accessory trays. Top tray is offset for cable storage underneath. Recessed tray sits 3.7" below surface to keep cables out of sight.
- Specify configuration, last letter of the code represents the following.
- 10ft cord.
- C = 2 AC, 1 USB-A 1.5A charge port, 1 USB-A 2.4A quick charge port
- D = 1 AC, 1 USB-A 1.5A charge port, 1 USB-A 2.4A quick charge port, 1 60W USB-C charge port
- E = 3 AC

PRODUCT CODE	PRICE	SIZE/INCHES			WEIGHT VOL	
		H	W	D	LBS	FT <sup>3</sup>
SCTAPTC	858	4.53	23.26	10.51	7.73	0.64
SCTAPTD	999	4.53	23.26	10.51	7.73	0.64
SCTAPTE	789	4.53	23.26	10.51	7.73	0.64

**SCTAOT • Collaborative Spaces Organizer Tray**

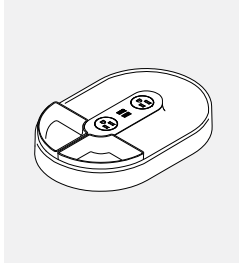

- Black plastic power tray with removable grey accessory trays.
- Specify configuration, last letter of the code represents the following:
- 10ft cord.
- C = 2 AC, 1 USB-A 1.5A charge port, 1 USB-A 2.4A quick charge port
- D = 1 AC, 1 USB-A 1.5A charge port, 1 USB-A 2.4A quick charge port, 1 60W USB-C charge port
- E = 3 AC

PRODUCT CODE	PRICE	SIZE/INCHES			WEIGHT VOL	
		H	W	D	LBS	FT <sup>3</sup>
SCTAOTC	639	4.28	12.40	8.32	1.50	0.26
SCTAOTD	779	4.28	12.40	8.32	1.50	0.26
SCTAOTE	570	4.28	12.40	8.32	1.50	0.26

**SCTAPR • Collaborative Spaces Recessed Power Tray**

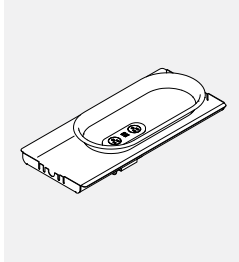

- Black plastic power tray. Recessed tray sits 3.7" below surface to keep cables out of sight.
- Specify configuration, last letter of the code represents the following:
- 10ft cord.
- C = 2 AC, 1 USB-A 1.5A charge port, 1 USB-A 2.4A quick charge port
- D = 1 AC, 1 USB-A 1.5A charge port, 1 USB-A 2.4A quick charge port, 1 60W USB-C charge port
- E = 3 AC

PRODUCT CODE	PRICE	SIZE/INCHES			WEIGHT VOL	
		H	W	D	LBS	FT <sup>3</sup>
SCTAPRC	760	6.4	23.26	10.51	6.06	0.91
SCTAPRD	900	6.4	23.26	10.51	6.06	0.91
SCTAPRE	691	6.4	23.26	10.51	6.06	0.91

**SCTACT • Collaborative Spaces PET Felt Wire Manager**

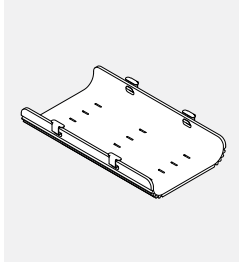

- PET Felt Wire Manager hangs from four brackets under the surface.
- Includes black painted metal brackets.
- PET Felt available in standard finishes.

PRODUCT CODE	PRICE	SIZE/INCHES			WEIGHT VOL	
		H	W	D	LBS	FT <sup>3</sup>
SCTACT	80	4	11	26	1.10	0.66

**SCCR • Coat Rack Cart**

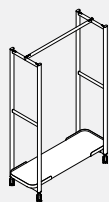

- Cart includes side rails for compatible accessories and a single top rail for hanging coats, jackets, etc.
- Shelf available in LP - Low Pressure laminate.
- Painted aluminum frame available in standard paint finishes.
- Casters are lockable, in a choice of two finishes.

PRODUCT CODE	PRICE LP	SIZE/INCHES			WEIGHT LBS	VOL FT <sup>3</sup>
		H	W	D		
SCCR1848	1818	72	48	18	56.82	36.04
SCCR1860	1876	72	60	18	62.77	45.05

**SCCS • Shelf Cart**

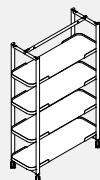

- Cart includes four fixed shelves with metal trim detail. Vertical rails accept PET privacy panels (sold separately) to create space division within open areas.
- Horizontal top rail accepts compatible accessories.
- Shelves available in LP - Low Pressure laminate.
- Painted aluminum frame available in standard paint finishes.
- Casters are lockable, in a choice of two finishes.

PRODUCT CODE	PRICE LP	SIZE/INCHES			WEIGHT LBS	VOL FT <sup>3</sup>
		H	W	D		
SCCS1848	3400	72	48	18	123.88	36.04

**SCCM • Media Cart**

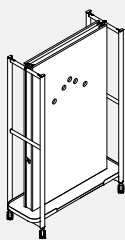

- Media Cart includes a bottom shelf and thermally fused laminate TV board. Short side panels feature small cutout for wire pass thru and hook for wire management.
- Side rails accept compatible accessories.
- Shelf available in LP - Low Pressure laminate.
- Back panel is removeable for access to cavity for cable management. Back panel is whiteboard laminate.
- SCCMEP models include a power bar (SCCAMP) mounted internally.
- SCCMNE models do not include any power.
- Units 48" wide can accept TV's up to 55", not exceeding 50lbs.
- Units 60" wide can accept TV's up to 60", not exceeding 50lbs.
- Painted aluminum frame available in standard paint finishes.
- Casters are lockable, in a choice of two finishes.
- Note: TV mount included. TV and video conferencing units are not included.

PRODUCT CODE	PRICE LP	SIZE/INCHES			WEIGHT LBS	VOL FT <sup>3</sup>
		H	W	D		
SCCMNE1848	3343	72	48	18	170.92	36.04
SCCMNE1860	3772	72	60	18	213.73	45.05
SCCMNE1848	3945	72	60	18	214.23	45.05
SCCMNE1860	3515	72	48	18	171.42	36.04

**SCCSW • Single Sided Whiteboard Cart**

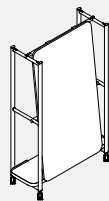

- Cart includes one fixed shelf with metal trim detail, accessible from behind whiteboard.
- Front of vertical whiteboard panel is whiteboard only.
- Side rails accept compatible accessories.
- Back of vertical whiteboard panel is DWTL P - Designer White laminate with DWE - Designer White edging.
- Shelf available in LP - Low Pressure laminate.
- Painted aluminum frame available in standard paint finishes.
- Casters are lockable, in a choice of two finishes.

PRODUCT CODE	PRICE LP	SIZE/INCHES			WEIGHT LBS	VOL FT <sup>3</sup>
		H	W	D		
SCCSW1848	3011	72	48	18	106.37	36.04
SCCSW1860	3531	72	60	18	191.07	45.05

**SCCDW • Double Side Whiteboard Cart**

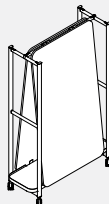

- Cart includes one fixed shelf with metal trim detail, accessible from behind whiteboard.
- Front of vertical whiteboard panels are whiteboard only.
- Side rails accept compatible accessories.
- Back of vertical whiteboard panels are DWTL P - Designer White laminate with DWE - Designer White edging.
- Shelf available in LP - Low Pressure laminate.
- Painted aluminum frame available in standard paint finishes.
- Casters are lockable, in a choice of two finishes.

PRODUCT CODE	PRICE LP	SIZE/INCHES			WEIGHT LBS	VOL FT <sup>3</sup>
		H	W	D		
SCCDW1848	4061	72	48	18	153.96	36.04
SCCDW1860	5027	72	60	18	191.07	45.05

**SCCCW • Combo Whiteboard Cart**

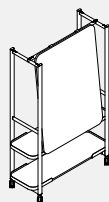

- Cart includes two fixed shelves with metal trim detail. Bottom shelf is accessible from both sides of cart, top shelf accessible from behind whiteboard.
- Front of vertical whiteboard panel is whiteboard only.
- Side rails accept compatible accessories.
- Back of vertical whiteboard panel is DWTL P - Designer White laminate with DWE - Designer White edging.
- Shelves available in LP - Low Pressure laminate.
- Painted aluminum frame available in standard paint finishes.
- Casters are lockable, in a choice of two finishes.

PRODUCT CODE	PRICE LP	SIZE/INCHES			WEIGHT LBS	VOL FT <sup>3</sup>
		H	W	D		
SCCCW1848	3250	72	48	18	115.66	36.04
SCCCW1860	3736	72	60	18	150.33	45.05



**SCCRW • Removable Whiteboard Cart**

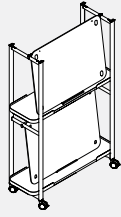

- Cart includes two fixed shelves with spacers for removable whiteboards.
- Includes five lightweight removable whiteboard panels.
- One whiteboard can be stored at the top and four at the bottom.
- Cart accepts five lightweight removable whiteboard panels maximum.
- Whiteboards feature whiteboard front and DWTHP - Designer White laminate back with DWE - Designer White edge.
- Hanging bracket finish matches the cart frame finish.
- Shelves available in LP - Low Pressure laminate.
- Side rails accept compatible accessories.
- Painted aluminum frame available in standard paint finishes.
- Casters are lockable, in a choice of two finishes.

PRODUCT CODE	PRICE LP	SIZE/INCHES			WEIGHT		VOL	
		H	W	D	LBS	FT <sup>3</sup>		
SCCRW1848	5013	72	48	21	188	42.05		
SCCRW1860	5724	72	60	21	245.61	52.56		

**SCCEW • Empty Removeable Whiteboard/Privacy Cart**

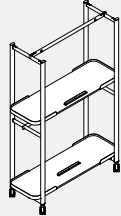

- Cart includes two fixed shelves with spacers for removable whiteboards.
- Cart accepts five lightweight removable whiteboard panels maximum.
- One whiteboard can be stored at the top and four at the bottom.
- To order Removeable Whiteboard, specify SCCAWB3336 for the 48" wide cart and SCCAWB3348 for the 60" wide cart.
- Hanging bracket finish matches the cart frame finish.
- Shelves available in LP - Low Pressure laminate.
- Side rails accept compatible accessories.
- Painted aluminum frame available in standard paint finishes.
- Casters are lockable, in a choice of two finishes.

PRODUCT CODE	PRICE LP	SIZE/INCHES			WEIGHT		VOL	
		H	W	D	LBS	FT <sup>3</sup>		
SCCEW1848	2455	72	48	21	82.31	42.05		
SCCEW1860	2597	72	60	21	105.70	52.56		

**SCHC • Hospitality Cart**

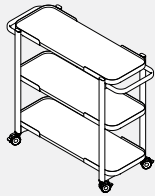

- Hospitality Cart includes three fixed shelves with metal trim.
- Surfaces available in LP - Low Pressure laminate.
- Legs and handles are painted aluminum available in standard paint finishes.
- Note: size is inclusive of handles, shelf sizing is approximately 10" shorter.

PRODUCT CODE	PRICE LP	SIZE/INCHES			WEIGHT		VOL	
		H	W	D	LBS	FT <sup>3</sup>		
SCHC2233	2653	41	43	22	81.31	15.39		
SCHC2239	2763	41	49	22	95	17.96		

**SCCAPP • Cart Mounted PET Felt Privacy Panels**

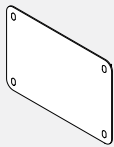

- Lightweight removeable PET Felt panels, specify SCCAPP3248 for the 48" w cart and SCCAPP3260 for the 60" w cart.
- Snaps onto (SCCEWxxxx) vertical rails at various shelf heights to create space division and privacy.
- Cover caps painted metal finish should be specified to match the cart finish.
- PET Felt available in standard finishes.

PRODUCT CODE	PRICE	SIZE/INCHES			WEIGHT VOL	
		H	W	D	LBS	FT <sup>3</sup>
SCCAPP3248	223	32	48	0.5	4.16	0.32
SCCAPP3260	331	32	60	0.5	5.16	0.40

**SCCAMP • Concealed Power Unit**

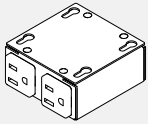

- Provided inside SCCMEPxxxx media units, can be added to SCCNMExxxx in field.
- Includes two AC outlets.
- Compatible with Mobile Media Carts only.
- BLK - Black finish only.

PRODUCT CODE	PRICE	SIZE/INCHES			WEIGHT VOL	
		H	W	D	LBS	FT <sup>3</sup>
SCCAMP	251	1.5	3	3.00	0.50	0.01

**SCCAMT • Media Tray**

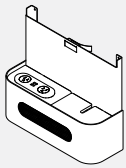

- Attaches to the front of the SCCMEPxxxx/ SCCNMExxxx to provide a wire catch, wireless receiver area and easily accessible power at the front of the media carts.
- Compatible with Mobile Media Carts only.
- Tray is painted metal with a PET Felt insert.
- PET Felt available in 18 standard finishes.
- SCCAMT is empty and has no power capabilities.
- Specifying configuration, last letter of the code represents the following:
  - C = 2 AC, 1 USB-A 1.5A charge port, 1 USB-A 2.4A quick charge port
  - D = 1 AC, 1 USB-A 1.5A charge port, 1 USB-A 2.4A quick charge port, 1 60W USB-C charge port
  - E = 3 AC

PRODUCT CODE	PRICE	SIZE/INCHES			WEIGHT VOL	
		H	W	D	LBS	FT <sup>3</sup>
SCCAMT	611	13.80	14.57	5.60	12	0.65
SCCAMTPC	1189	13.80	14.57	5.60	12	0.65
SCCAMTPD	1329	13.80	14.57	5.60	12	0.65
SCCAMTPE	1120	13.80	14.57	5.60	12	0.65

**SCCAC • Accessory Cup**



- Hangs onto any team cart horizontal top or side rail. Black only.

PRODUCT CODE	PRICE	SIZE/INCHES			WEIGHT VOL	
		H	W	D	LBS	FT <sup>3</sup>
SCCAC	9	3.7	3.3	3.00	0.15	0.02

**SCCAH • Hook for Team Cart**



- Hangs onto any team cart horizontal top or side rail.
- Black only
- Maximum capacity of 10 lbs.

PRODUCT CODE	PRICE	SIZE/INCHES			WEIGHT VOL	
		H	W	D	LBS	FT <sup>3</sup>
SCCAH	6	1.8	1.3	0.65	0.10	

**SCCAWB • Whiteboard**

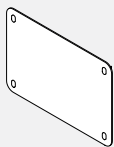

- Lightweight removeable whiteboard panels.
- Specify SCCAWB3336 for the 48" w cart and SCCAWB3348 for the 60" w cart.
- Back of whiteboard is DWT - Designer White with DWE - Designer White edging.
- Cover caps painted metal finish should be specified to match the cart finish.
- Horizontal and vertical mounting on wall rail(s).

PRODUCT CODE	PRICE	SIZE/INCHES			WEIGHT VOL	
		H	W	D	LBS	FT <sup>3</sup>
SCCAWB3336	501	33	36	0.50	17.62	0.34
SCCAWB3348	620	33	48	0.50	23.32	0.46

**SCCAWBR • Whiteboard Wall Rail**

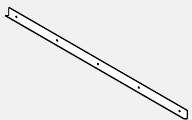

- Wall rail for whiteboards.
- Accepts SCCAWBxxxx.
- Metal extrusion in BLK - Black only.

PRODUCT CODE	PRICE	SIZE/INCHES			WEIGHT VOL	
		H	W	D	LBS	FT <sup>3</sup>
SCCAWBR36	51	2	36	1	1.27	0.04
SCCAWBR48	63	2	48	1	1.71	0.05
SCCAWBR72	102	2	72	1.00	2.54	0.08
SCCAWBR96	126	2	96	1.00	3.42	0.11

**SCCALSL • Laptop Shelf**



- Laminate laptop shelf with dual bracket.
- Can be flipped vertically to store when cart is not in use.
- Shelf available in LP - Low Pressure laminate.
- Bracket included is painted metal finish and should be specified to match the cart finish.

PRODUCT CODE	PRICE	SIZE/INCHES			WEIGHT VOL	
		H	W	D	LBS	FT <sup>3</sup>
SCCALSL1219	243	3	19	12	11.07	

**SCOR • Occasional Side Table, Round Top**

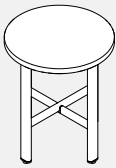

- Occasional End Table includes leg assembly, cross beams and one worksurface.
- Surface available in LP - Low Pressure laminate.
- Legs and cross beam are painted aluminum available in standard paint finishes.

PRODUCT CODE	PRICE LP	SIZE/INCHES			WEIGHT LBS	VOL FT <sup>3</sup>
		H	W	D		
SCOR1818	514	21	18	18	18.52	3.94
SCOR2424	584	21	24	24	26.53	7.01

**SCOC • Occasional Side Table, Square Top**

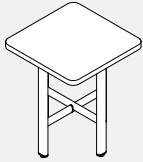

- Occasional End Table includes leg assembly, cross beams and one worksurface with a small 1.5" radius at each corner.
- Surface available in LP - Low Pressure laminate.
- Legs and cross beam are painted aluminum available in standard paint finishes.

PRODUCT CODE	PRICE LP	SIZE/INCHES			WEIGHT LBS	VOL FT <sup>3</sup>
		H	W	D		
SCOC1818	514	21	18	18	21.12	3.94
SCOC2424	584	21	24	24	31.20	7.01

**SCOCL • Occasional Side Table, Square Top, Larger Radius**

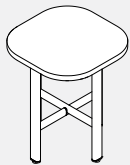

- Occasional End Table includes leg assembly, cross beams and one worksurface with a larger 9" radius at each corner.
- Surface available in LP - Low Pressure laminate.
- Legs and cross beam are painted aluminum available in standard paint finishes.

PRODUCT CODE	PRICE LP	SIZE/INCHES			WEIGHT LBS	VOL FT <sup>3</sup>
		H	W	D		
SCOCL1818	550	21	18	18	21.12	3.94
SCOCL2424	648	21	24	24	31.20	7.01

**SCOCC • Occasional Coffee Table, Round Top**

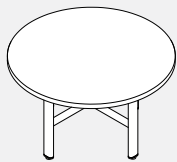

- Occasional End Table includes leg assembly, cross beams and one worksurface.
- Surface available in LP - Low Pressure laminate.
- Legs and cross beam are painted aluminum available in standard paint finishes.

PRODUCT CODE	PRICE LP	SIZE/INCHES			WEIGHT LBS	VOL FT <sup>3</sup>
		H	W	D		
SCOCC2424	563	17	24	24	25.55	5.67
SCOCC3030	643	17	30	30	35.76	8.86
SCOCC3636	739	17	36	36	48.13	12.76

**SCOCS • Occasional Coffee Table, Square Top**

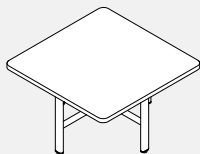

- Occasional Coffee Table includes leg assembly, cross beams and one worksurface with a small 1.5" radius at each corner.
- Surface available in LP - Low Pressure laminate.
- Legs and cross beam are painted aluminum available in standard paint finishes.

PRODUCT CODE	PRICE LP	SIZE/INCHES			WEIGHT LBS	VOL FT <sup>3</sup>
		H	W	D		
SCOCS2424	563	17	24	24	30.22	5.67
SCOCS3030	643	17	30	30	43.10	8.86

**SCOCSL • Occasional Coffee Table, Square Top, Larger Radius**

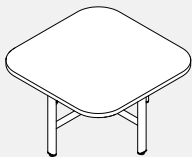

- Occasional Coffee Table includes leg assembly, cross beams and one worksurface with a larger 9" radius at each corner.
- Surface available in LP - Low Pressure laminate.
- Legs and cross beam are painted aluminum available in standard paint finishes.

PRODUCT CODE	PRICE LP	SIZE/INCHES			WEIGHT LBS	VOL FT <sup>3</sup>
		H	W	D		
SCOCSL2424	563	17	24	24	29.11	5.67
SCOCSL3030	643	17	30	30	41.99	8.86

**SCOCC • Occasional Coffee Table, Racetrack Top**

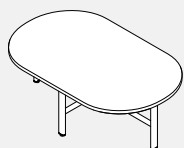

- Occasional Coffee Table includes leg assembly, cross beams and one racetrack worksurface.
- Surface available in LP - Low Pressure laminate.
- Legs and cross beam are painted aluminum available in standard paint finishes.

PRODUCT CODE	PRICE LP	SIZE/INCHES			WEIGHT LBS	VOL FT <sup>3</sup>
		H	W	D		
SCOCC2442	676	17	24	42	42.78	9.93
SCOCC3048	777	17	30	48	57.13	14.18

**SCLCC • Laptop Table, Racetrack Top, Wheel and Foot Base**



- Laptop Table includes leg assembly and two wheels with rubber trim, one leg assembly with a foot and one racetrack worksurface.
- Two bag hooks included, one on the exterior of each leg, mounted just under the surface for easy access.
- Each bag hook accepts up to 10 lbs, and painted to match the legs.
- Legs, beams and hook are painted aluminum available in standard paint finishes.
- Wheel insert is painted to match the legs and beams.
- Surface available in LP - Low Pressure laminate.

PRODUCT CODE	PRICE LP	SIZE/INCHES			WEIGHT LBS	VOL FT <sup>3</sup>
		H	W	D		
SCLCC1633	901	26	33	16	25.60	6.51

**SCLCB • Laptop Table, Racetrack Top, Foot Base**



- Laptop Table includes two leg assemblies a foot and one racetrack worksurface.
- Two bag hooks included, one on the exterior of each leg, mounted just under the surface for easy access.
- Each bag hook accepts up to 10 lbs, and painted to match the legs.
- Legs and beams are painted aluminum available in standard paint finishes.
- Surface available in LP - Low Pressure laminate.

PRODUCT CODE	PRICE LP	SIZE/INCHES			WEIGHT LBS	VOL FT <sup>3</sup>
		H	W	D		
SCLCB1633	516	26	33	16	23.85	6.51

**SCLTC • Laptop Table, Rectangular Top, Small Radius, Wheel and Foot Base**

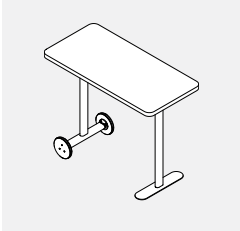

- Laptop Table includes leg assembly and two wheels with rubber trim, one leg assembly with a foot and one rectangular worksurface with a small 1.5" radius at each corner.
- Two bag hooks included, one on the exterior of each leg, mounted just under the surface for easy access.
- Each bag hook accepts up to 10 lbs, and painted to match the legs.
- Legs and beams are painted aluminum available in standard paint finishes.
- Wheel insert is painted to match the legs and beams.
- Surface available in LP - Low Pressure laminate.

PRODUCT CODE	PRICE LP	SIZE/INCHES			WEIGHT LBS	VOL FT <sup>3</sup>
		H	W	D		
SCLTC1633	901	26	33	16	27.64	6.51

**SCLTB • Laptop Table, Rectangular Top, Base**

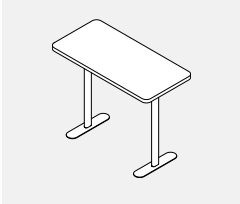

- Laptop Table includes two leg assemblies a foot and one rectangular worksurface with a small 1.5" radius at each corner.
- Two bag hooks included, one on the exterior of each leg, mounted just under the surface for easy access.
- Each bag hook accepts up to 10 lbs, and painted to match the legs.
- Legs and beams are painted aluminum available in standard paint finishes.
- Surface available in LP - Low Pressure laminate.

PRODUCT CODE	PRICE LP	SIZE/INCHES			WEIGHT LBS	VOL FT <sup>3</sup>
		H	W	D		
SCLTB1633	516	26	33	16	25.88	6.51

---

## Global offices in Canada

### Head Office

560 Supertest Road  
Toronto, Ontario  
M3J 2M6  
T (416) 650-6500

### Toronto Sales Office

1350 Flint Road  
Toronto, Ontario  
M3J 2J7  
T (416) 661-3660

### Moncton

268 Coverdale Road  
Riverview, New Brunswick  
E1B 3J2  
T (506) 858-8383

---

## Showrooms

### Calgary

237 8 Avenue SE, Suite 302  
Calgary, Alberta  
T2G 5C3  
T (403) 250-7770

### Montreal

1010 Sainte-Catherine Street West  
Mezzanine 2  
Montreal, Quebec  
H3B 1E7T  
(514) 866-4331

### Ottawa

251 Laurier Avenue West, Suite 400  
Ottawa, Ontario  
K1P 5J6  
T (613) 234-2881  
*Please call ahead to book an appointment.*

### Edmonton

10158 103 Street NW, Suite 201  
Edmonton, Alberta  
T5J 0X6  
T (780) 444-8922

### Toronto

1350 Flint Road  
Toronto, Ontario  
M3J 2J7  
T (416) 661-3660

### Vancouver

675 West Hastings Street, Suite 1000  
Vancouver, British Columbia  
V6B 1N2  
T (604) 432-1701

### Halifax

1061 Marginal Road, Suite 120  
Halifax, Nova Scotia  
B3H 4P7  
T (902) 422-7434

### Toronto - The Blueprint

(MetroCentre)  
200 Wellington Street West, Suite 1602  
Toronto, Ontario  
M5V 3C7

### Winnipeg

111 Lombard Avenue, Suite 220  
Winnipeg, Manitoba  
R3B 0T4  
T (204) 925-3350