

BOULEVARD 1 PANELS**Features:**

- Desk height power and data management
- Patented "Knuckle-Loc", rigid connection, prevents light and sound transmission
- Built-in acoustical/tackable properties
- Sectional multi-accent design options
- Fabric surfaces are able to be replaced on-site
- Frame incorporates 1" centred slots for component adjustability
- Requires no additional top caps, end caps, trim caps, hinges, kick plates or clips
- Simple to specify
- Reduced installation time
- Easy to reconfigure
- High-tech look/stackable grid appearance
- Rigid, no sway, straight panel sight line
- Self levelers reduce assembly time, ensure even height
- Over panels extend to 10 feet to enclose an office in fabric and glazed options
- Patented Raceway cover easily removed
- Raceway panels top and bottom portion semi tackable

Construction:

- Rigid extruded aluminum, finished frame, self-leveling 2 5/8" thick panel
- 1 1/8" sound absorbent Mineral Wool each side of hardboard septum Sizes:
- 8 Heights: 29", 37", 42", 50", 54", 58", 66" 74" and 82"
- 9 Widths: 6", 18" to 60" in 6" increments, 72" wide in selected panel configurations.

Adjustability:

- 3" glide stem permits 2 1/2" height adjustment
- Slotted at 1" increments
- Over panels, 8", 16", 24", 37" and 42" for enclosed offices (Non-slotted) Acoustic Rating
- .80NRC/26STC

Door:

- 2 door panel widths, glazed/unglazed, lockable, reversible
- 2 sliding door widths, non-lockable

Flexibility:

- Universal connector

Panel Finishes:

- 2 grades of fabric, air flow grill, glaze, tempered glass, laminate & COM

Electrical:

- Desk height 8 wire/4 circuit - 1 dedicated

Communication:

- Desk height data channel
- Raceway cover easily removed
- Fabric covered raceways available

SYSTEM 3 PANELS**Features:**

- Base power and data lay-in
- Desk height power and data feed thru
- Top data lay-in
- Patented "Knuckle-Loc", rigid connection, prevents light and sound transmission
- Removable multi-functional tile design options
- Fabric surfaces are able to be replaced on-site
- Reduced installation time
- Easy to reconfigure
- High-tech look/stackable grid appearance
- Rigid, no sway, straight panel sight line
- Self levelers reduce assembly time, ensure even height
- Over panels extend height to enclose an office in fabric, glazed or laminate options
- Raceway cover easily removed

Construction:

- Rigid extruded aluminum

Sizes:

- 5 Heights: 34", 42", 50", 54", 66"
- 8 Widths: 18" to 60"

Adjustability:

- 3" glide stem permits 2 1/2" height adjustment
- Slotted at 1" centres
- Over panels, 8" and 16" (Non-slotted)

Door:

- 2 widths, glazed/solid, lockable, reversible
- 2 sliding door widths, non-lockable

Flexibility:

- Universal connector

Panel Finishes:

- Fabric, air flow accessory, tempered glass, laminate, whiteboard, corkboard (at base only)

ELECTRICAL FOR BOULEVARD 1 PANELS**Features:**

- Customized power capabilities in each panel
- State-of-the-art snap-in electrical
- 8 wire with 3 regular 15 AMP circuits and 1 isolated 15 AMP circuit.
- 3N and 8K electrical available upon request.
- Snap-in installation - harnesses, junction boxes, duplexes
- Accessibility makes changing circuits easy
- Flexibility in choice of duplexes within panel: choice of circuits for each duplex; choice of quantity of duplexes (1 or 2 duplexes per panel)

- Electrical cords are concealed
- Separate large channel for data
- Change electrical without moving pedestals
- Lower installation/reconfiguration costs
- Data terminals snap into cable holder
- Floor or ceiling feed
- Duplexes accessible from both sides

ELECTRICAL FOR SYSTEM 3 PANELS**Features:**

- Customized power capabilities in each panel
- State-of-the-art snap-in duplex receptacles
- 8 wire with 3 regular 15 AMP circuits and 1 isolated 15 AMP circuit
- Snap-in installation - harnesses, junction boxes, duplexes

- Accessibility makes changing circuits easy
- Flexibility in choice of duplexes within panel
- Data terminals snap into base raceway cover and mid panel electrical tile
- Floor or ceiling feed
- Duplexes accessible from both sides

WORKSURFACES / HARDWARE**Features:**

- One universal cantilever support
- Pedestal eliminates need for end panel/cantilever
- Grommets are not needed
- Continuous cable accessibility across back
- Adjustable to any height, in 1" increments
- Flush abutment side edge minimize seam crevice
- Metal-to-metal connections (Metal Inserts)
- Additional cable manager under worksurface

Construction:

- Medium-density particle board 1 1/16" thick

Sizes:

- 3 Depths: 18", 24" and 30"
- 12 Widths: 18" to 84" in 6" increments

Finishes:

- Tops: High Pressure Laminate, Low Pressure Laminate or Wood
- Edges: Edge banded PVC or Wood

Types:

- Transaction, keyboard, rectangular worksurface, corner, curved, D-top, P-top, Arc-top and freestanding

OVERHEAD STORAGE**Features:**

- Steel and all laminate based options
- Panel mount and up-mount options
- Completely enclosed unit for 16" overheads
- Style dependent- ship fully assembled or knocked down
- 13.5" inside height for oversized binders
- Metal-to-metal connection
- Lock secures into bottom shelf
- Doors operate smoothly
- Flipper door retrofittable on site
- Safety bracket used for extra support
- Reinforcement built in for larger unit
- Can be removed and reconfigured without disassembly

Fronts:

- Open or closed fronts
- AODA compliant options available

Sizes:

- Overheads - 7 widths in 6" increments
- Shelves - 7 widths in 6" increments
- 13.5" deep welded overheads
- 14.2" deep AODA overheads
- 16.5" deep welded overheads for EDP, ring binder, letter/legal

Paint:

- Dry epoxy powder coating

PEDESTALS**Features:**

- Premium quality steel reinforced welded construction
- Double wall construction on all drawer fronts
- Fully progressive suspension system
- Centre pull
- Worksurface supporting option
- Full extension roller bearing glides on all file drawers
- Rubber bumpers for quietness
- Movable drawer divider in box drawers
 - Pencil Tray
 - Each file drawer includes a hanging file bar (22" and 28" depth only)
- 3 depths with varying filing capacity
- Random or specific keying instructions available

Construction:

- Double wall drawer fronts
- 18-20 gauge steel case components

Sizes:

- (Prime) 18", 22", 28" depth
- (9300) 19", 23", 29" depth

Types:

- Worksurface Supporting, Mobile, Freestanding

Paint:

- Dry epoxy powder coating

HOW BOULEVARD 1 CAN REDUCE YOUR COSTS**Finished Panel:**

- No inventory costs for connectors, trim caps, top caps, kick plates and clips.
- Less time required to install, or to disassemble, move and re-install.

Fewer Parts:

- Only 1 universal cantilever and 3 brackets are needed to build most workstations.
- Easy to attach and remove components from panels.
- Universal post for 2-way, 3-way and 4-way applications.

Desk Height Electric:

- Ease of initial electrical installation lowers energy management costs.
- Snap-in electrical components reduce reconfiguration costs.
- Can customize power in each panel, pay only for what is required.

Simplified Specifications:

- Fewer parts and components make specifying, ordering, and verifying less work.
- Product fits a 6" planning module.

Replaceable Panels:

- Panels can be re-upholstered on site.
- Communications/Data Channel:
 - Desk height data channel reduces time to install and change cables.

Floor to Ceiling Enclosed Office:

- Re-usable enclosed offices with doors eliminate future costs for drywall demolition, new construction, mess and extensive cash flow.
- Depreciation expense indirectly increases cash flow.

Warranty:

- Limited Lifetime Warranty on materials and workmanship.

Product:

- Priced less than most other "A" Grade panel systems.

HOW BOULEVARD SYSTEM 3 REDUCES YOUR COSTS**Finished Panel:**

- No inventory costs for connectors, top caps, kick plates and clips.
- Less time required to install, or to disassemble, move and re-install.

Fewer Parts:

- Only 1 universal cantilever and 3 brackets are needed to build most workstations.
- Easy to attach and remove components from panels.
- Universal post for 2-way, 3-way and 4-way applications.

Base Panel Electric System:

- Ease of initial electrical installation lowers energy management costs.
- Snap-in electrical components reduce reconfigurations costs.
- Can customize power in each panel, pay only for what is required.

Simplified Specifications:

- Fewer parts and components make specifying, ordering, and verifying less work.
- Product fits a 6" planning module.

Replaceable Panel Tiles:

- Over Panels and face tiles can be added and interchanged as needs change.
- Communications/Data Channel:
 - Base and top lay-in communications channel reduces time to install and change cables.

Warranty:

- Limited Lifetime Warranty on materials and workmanship.

Product:

- Priced less than most other "A" Grade panel systems.

Value-Added Benefits

On the following pages, we selected a grouping of Boulevard 1, System 3 configurations, some with electrical components and task lights, to give you a better understanding of our product's specifications as they relate to workstations. Our objective is to not only illustrate applications using panels and components, but also to have this serve as a pricing exercise.

All of the value-added benefits of the Boulevard 1 are standard as follows:

- Desk height power and data capabilities.
- Finished panel including top, corner and end caps.
- Sectional panel with multiple fabric options.
- Ease of installation and reconfigurations.
- Removable fabric for on-site refurbishing.
- Exceptional storage capacity in pedestals, overheads, lateral files, storage cabinets and towers.
- Simplified specifications.

All of the value-added benefits of the Boulevard System 3 are standard as follows:

- Base power and data capabilities.
- Finished panel including top and corner.
- Monolithic or Pass-Thru panels with multiple fabric options.

- Ease of installation and reconfiguration.
- Removable fabric tiles in Pass-Thru Panels for on-site refurbishing.
- Exceptional storage capacity in pedestals, overheads, lateral files, storage cabinets and towers.
- Simplified specifications.

All of the value-added benefits of the Diet System are standard as follows:

- Finished panel including top, corner and end caps.
- Sectional panels with multiple fabric options.
- Ease of installation and reconfigurations.
- Removable fabric for on-site refurbishing.
- Exceptional storage capacity in pedestals, overheads, lateral files, storage cabinets and towers.
- Simplified specifications.

When specifying Boulevard 1, Boulevard System 3 or Diet, you benefit from the ability to:

- Customize the energy management.
- Minimize the number of necessary parts.
- Offer a competitive list price.

NOTE: If Key Alike Instructions are not submitted to GLOBAL CONTRACT with the Customer's Purchase Order, all components will be keyed randomly.

WOOD GRAIN (WG) LAMINATE DIRECTION



* Panel general direction will default to vertical if monolithic panel is 54" high and if raceway panels are on same order.

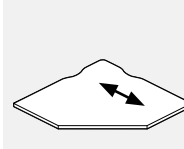
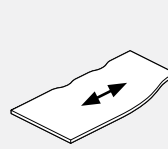
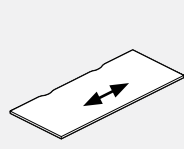
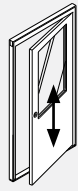

All Panels
With Exception of 66" or higher panels, the grain is vertical.

BPD
Doors.

BWS
Worksurfaces.

BWSC
Worksurfaces.

BWCF
Corner Worksurfaces.

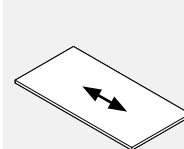
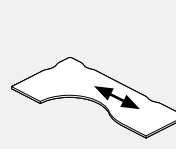
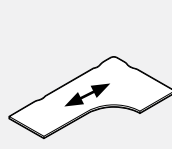
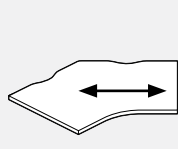
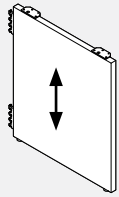
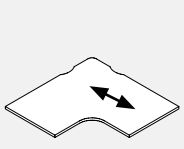

BWCL
Corner Worksurfaces.

BHFG
Full Gable.

BWAC Angled Corner
Worksurfaces

BWCE
Extended Worksurfaces.

BWCEC
Extended Worksurfaces.

BK
Desking Worksurfaces.

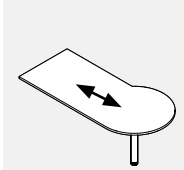
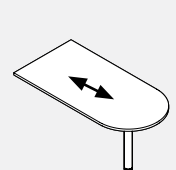
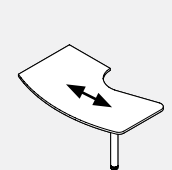
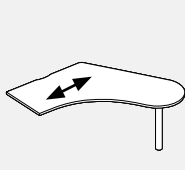
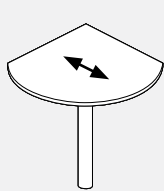
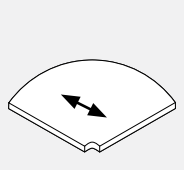

BWR
Radius Worksurfaces.

BWRTD
Teardrop Worksurfaces.

BWC
Extended "D"
Worksurfaces.

BWSL
Curvilinear Work-
surfaces.

BWD
Worksurfaces.

BWP
Worksurfaces.

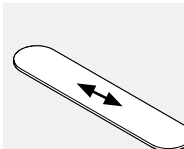
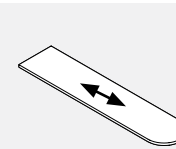
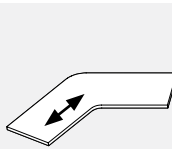
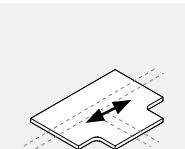
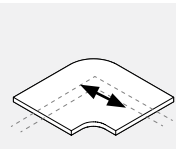
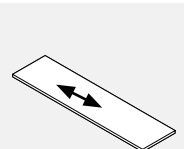

BWT
Transaction Worksurfaces.

BWTC
Corner Transaction
Worksurfaces.

BWTT
Transaction Work-
surfaces.

BWTAC
Transaction Worksur-
faces.

BWTD "D"
Transaction Worksurfaces.

BWTD "D"
Transaction Worksurfaces.

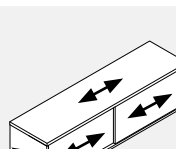
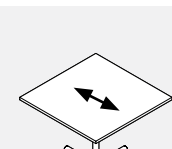
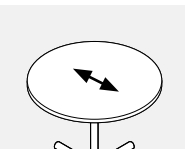
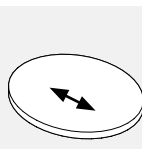
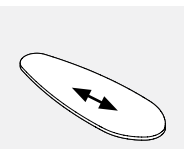

BWTE
Ellipse Transaction
Worksurfaces

BWTP
Round Transaction
Worksurfaces.

BWCD
Round Tables.

BWSQ
Square Tables.

BSP
Laminate Divider Storage

Boulevard 1 Panel System

The Boulevard philosophy is based on simplicity. A product that is simple to install... simple to reconfigure... and simple to specify, without sacrificing delivery time or quality.

Technically superb and exceptionally precise aluminum extrusion and die-cast fitments achieve exact levels of consistency, panel after panel; everything fits, aligns, and assembles, first time, every time. Most of all it requires very few of the "small parts" associated with most systems. This cross-market integration is celebrated in Boulevard.

Truly a system of broad application, whether installed in a high-tech environment, factory application or executive office, Boulevard will perform! We invite you to share with us a product designed, built and marketed for a global economy.

Our Mission

Our mission is to continue to develop and offer innovative, quality office furniture to value-oriented customers, through a dealer network that provides consistent, high quality service. Our approach in the contract furniture industry is to focus on customer concerns and needs to develop products that minimize your costs of ownership. It represents the culmination of creativity, industry expertise, specialists, and integrity to help you achieve

cost-effective solutions to problems. Our vision is to create a company-wide environment that supports constant improvement and promotes customer satisfaction. We believe that as good as we are today, we must be better tomorrow. Thus, our desire to improve is both continuous and tireless.

Environmental Commitment

At Global Contract, protecting the next generations' environment is of paramount concern. Global Contract believes that it is our responsibility to help protect the environment for future generations. We continue to operate with the environment in mind, making wise business decisions that help protect the earth and its precious natural resources. Our manufacturing procedure incorporates the latest technology for painting products, using a dry epoxy powder or gel paint. This process produces no toxic residue, and therefore is environmentally safe, while other manufacturers still use the wet paint process. Our packaging, veneer selections, and reduction in waste programs all contribute to a better environment. In addition, our concern for the reduction of finishing emissions and wood dust has resulted in a healthier work environment in many ways, including this price book, printed on recycled paper.

Technical Information

Panels

- All panels are 2 5/8" thick.
- Lightweight aluminum box frame construction creates superior panel rigidity.
- Panel frame finish is durable epoxy powder coated.
- Hang-on capabilities at 1" increments.
- Patented "Knuckle-Loc" design provides solid panel-to-panel connection for fast installation and reconfiguration.
- Knuckle lock feature ensures even panel heights throughout installation.
- 3" glide stem permits 2 1/2" height adjustment.
- Panel sizes are actual, eliminating creepage.
- Panels come complete, eliminating need for separate top, corner end trim and clips.
- Fabric is replaceable on site.
- All panels include 2 "Capture Strip" panel connectors.
- Fabric retainer is clear.
- Panels are UL listed and CSA approved and have a Class "A" fire rating except when Customer's Own Material (COM) is used.
- Centre septum above raceway overlaid on either side with tackable, 1 1/8" "Sound Absorbent Mineral Board".
- For glazing - Smoke developed index 500.
- For tempered glass, add "TG" to the end of the product code and add 20% to the price regardless of fabric grade.
- Solid metal sheet is an OPT option and price accordingly, however, the sheets are 48" wide and cannot be specified on 48" and wider unless they are railroaded. Contact your Customer Service Representative for more information.

Panel Options

- Laminate, whiteboard, or corkboard may be substituted for fabric on panels only, not raceways, see "OPT" column.
- Laminate and whiteboard are held in place with a PVC retainer matching the frame colour and can be retrofitted on site.
- Laminate and whiteboard options reduce the acoustical value of the panel.

Raceway Options

- Raceways are standard in PVC matching the panel frame finish.
- Fabric Covered Raceway (FRC) available. Aluminum raceway available.
- Wood veneer raceway available.
- Face mount electrical raceway available.
- Face mount openings are 1.5x2.85 for electrical and 1.37x2.755 for data.
- Cable capacity in raceways is 83 - 0.220" dia. cables (cat.6).

Desk Height Management

- Desk height electrical and communication raceway system.
- State-of-the-art engineering.
- Snap-in modularity of all electrical components including harnesses, junction boxes, duplexes and circuit designations.
- All power and data outlets are easily accessible from both sides of panel.
- 8 wire system with 4, 15 amp circuits (including 1 dedicated circuit).
- Optional facemount electrical with 2 duplexes per panel side.
- Outlet and circuit changes accomplished without disruption to workstation.
- Large raceway cavity permits storage of excess cables and equipment cords.
- Total flexibility for 8 wire system: choice of 1, 2 or 4 duplexes per panel; choice of circuitry in each duplex.
- Unique design of fire retardant PVC raceway cover permits access to raceway without disruption to equipment on worksurfaces.
- Clip-on communication management channel (BECC01 and BPH001) included with each raceway panel.
- Communication management channel accepts modular Data/Comm terminals (not supplied by Global Contract Inc.).

Posts

- Enables connection for multiple panel runs such as 90°, 45° or 60° angles and 2 way, 3 way or 4 way.
- Provides route for base, ceiling, and worksurface cable entry to a panel.
- Self levelling feature maintains even height of all connected panels.
- Solid lightweight aluminum extrusion fits together through a unique "Knuckle-Loc" design providing rigid post-to-panel connection.
- Includes all required panel connectors and caps.
- Posts add 2 5/8" to a panel run.
- Posts are 1/8" oversized to allow for "panel wrap around" of freestanding desks.
- For all panel runs with multiple posts, this 1/8" must be allotted for.

PANELS - GUIDELINES FOR ORDERING PRODUCT**Codes**

The product guide uses a numbering system with meaningful alphanumeric characters to create a simple-to-understand product number. This makes specifying the product much easier and more accurate.

Example of Panel: **BPRA6636 CHR CHR**

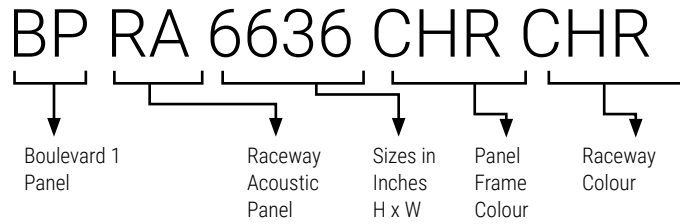

AN50

Inside Lower Fabric

AN50

Inside Upper Fabric

BE21

Outside Lower Fabric

BE21

Outside Upper Fabric

How to Specify

- Specify Boulevard 1 panel type and size by code.
- Specify panel frame finish - ie. CHR (Charcoal).
- Specify PVC raceway finish - ie. CHR (Charcoal). If PVC raceway colour not specified at time of order, default will be the panel frame colour.
- Specify all four panel fabric options if necessary.
- Some fabrics have directional pattern and cannot be applied horizontally or vertically. Panels wider than 60" will have fabrics applied horizontally (railroad). Please specify if you want adjacent panels and the rest of the installation upholstered the same way.

Example of Post: **BHP066 CHR**

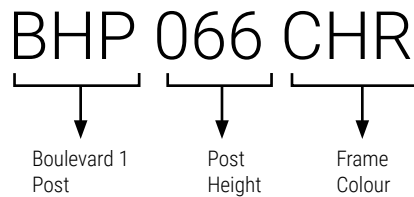
**How to Specify**

- Specify Boulevard 1 post by code.
- Specify frame colour - ie. CHR (Charcoal).

Raceways**PVC:**

- Standard, at time of order, includes 2 covers.
- Standard, when ordering individuals: RCSxxCOL.
- Facemount raceways: RCWxxD.

Fabric:

- Standard, at time of order: RCWxxFAB, panel mounted.
- Standard, when ordering individuals: 1006FRCxx, shipped separately.
- Facemount raceways: FCRxxD.

Aluminum:

- Standard, when ordering individuals: BARCxx,
- Facemount raceways: RCAxxD.

ORDERS

Each Order Must Include

- Purchase Order
- Layout showing where the image(s) appear in the run of panels.
- A completed Price Chart, showing the location of the image(s) on each appropriate panel.

Artwork must be submitted in accordance with the following artwork specifications.

NOTE: Final artwork specification approval must be given before order can be processed.

Transfer Devices

- E-mail up to 10MB to your Global Contract Customer Service Representative.
- Courier CD/DVD/USB stick to your Global Contract Customer Service Representative.

Artwork Specifications

- Non-Photographic artwork should be vector art, saved in Adobe Illustrator (.ai) or as an SVG or EPS (.eps)
- All bitmap or photographic artwork has to be at a minimum of 100 dpi at the full size of the panel to be printed.
- We accept Adobe CS5 files.
- Any linked files must be included or imbedded.
- Leave any PSD files unflattened
- All fonts must be converted to outlines.
- Do not convert to CMYK, leave all images as RGB if possible
- No Word, Powerpoint, Publisher or other Microsoft files can be used.
- Include a PDF or .jpg for reference when sending native Photoshop or Illustrator format files.

Colour Matching

- A Pantone colour reference must be supplied or we cannot accept responsibility for correct colour.
- When it is not possible to refer to Pantone colours, we will do our best to meet your requirements.

Image Clarity

- We will advise should the selected image not lend itself to the element size requested.

NOTE:

We reserve the right to put an order on hold when the files are found to be incomplete or when documents have been either incorrectly saved. Fonts not converted to curves or the

job appears not to be commercially acceptable.

Image Bleed:

To facilitate placement on the panel. Extension of the image past the finished visible area of the panel (bleed) is required

- Boulevard Panels need a 5" Bleed on all sides.

Example Of Image resolution:

The resolution required for a 36 wide x 24 high Boulevard panel at 100 dpi (minimum resolution)

The resolution required for a 36 wide x 24 high Boulevard panel at 300 dpi (higher quality)

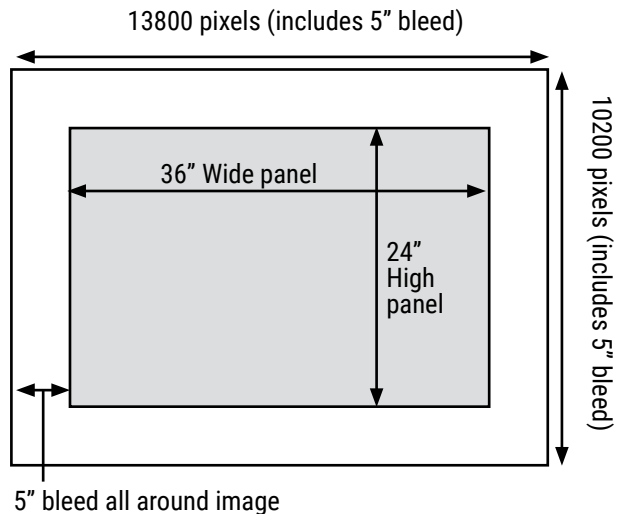
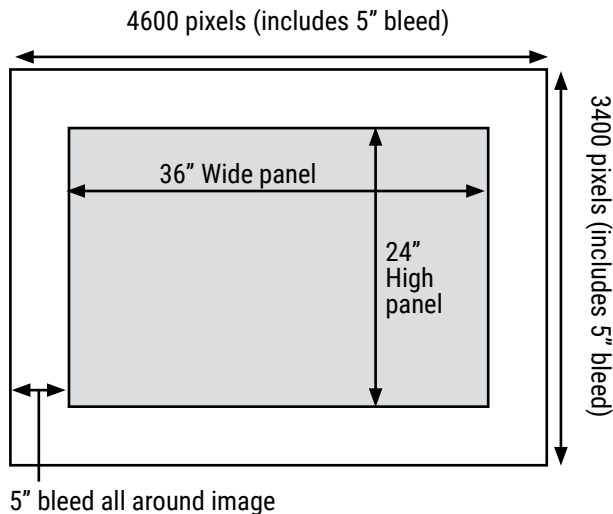

Pricing, Initial Set-Up Charge per Order:\$264 net

Boulevard 1 Panels • Below Raceway Only

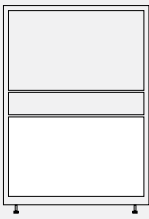

- This List applies to the following panels:
- BPRG
- BPRP
- BPAR

PANEL HEIGHT	PANEL WIDTH	LIST PRICE
29"	24"	309
29"	30"	364
29"	36"	421
29"	42"	476
29"	48"	537
29"	54"	589
29"	60"	641
29"	66"	693
29"	72"	747

Boulevard 1 • Above Raceway Only

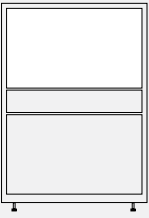

- This List applies to the following panels:
- BPRG
- BPRP

PANEL WIDTH	HEIGHT	LIST PRICE						
		42"	50"	54"	58"	66"	74"	82"
24"	N/A	183	217	248	317	384	446	
30"	N/A	218	259	295	377	452	527	
36"	N/A	259	299	340	431	520	610	
42"	N/A	286	340	392	488	589	693	
48"	N/A	324	382	438	550	661	791	
54"	N/A	353	415	476	604	731	852	
60"	N/A	384	452	520	661	800	935	
66"	N/A	415						
72"	N/A	452						

Boulevard Fabric Acoustic Panels

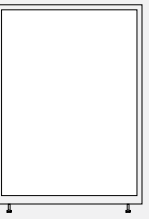

- This List applies to the following panels:
- BPF A

PANEL WIDTH	HEIGHT	LIST PRICE					
		50"	54"	58"	66"	74"	82"
24"	408	476	510	543	604	671	740
30"	483	557	602	641	717	791	867
36"	557	649	693	740	829	913	1001
42"	633	731	784	837	935	1040	1139
48"	711	823	880	935	1050	1160	1273
54"	784	905	970	1033	1154	1283	1409
60"	852	996	1063	1131	1266	1404	1539
66"	920	1063					
72"	996	1154					

Boulevard 1 Over Panels



- This List applies to the following Panels:
- BPOF

PANEL WIDTH	HEIGHT	LIST PRICE			
		16"	24"	37"	42"
24"	144	211	271	377	421
30"	171	248	324	446	499
36"	197	286	370	513	574
42"	227	324	421	589	649
48"	248	364	469	649	723
54"	279	408	520	723	800
60"	303	446	567	942	874
66"	324	476	610	852	942
72"	353	513	656	920	1018

Note: Prices shown are an upcharge to the panel price, please add to the list price of panel which you are specifying the graphic for.

BPRA • Acoustical Raceway Panel

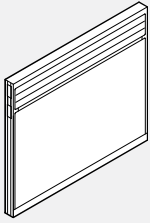

37" High

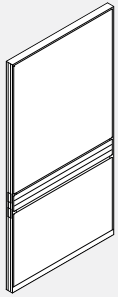

72" Wide

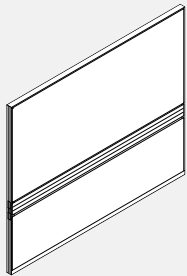

- Fabric above the raceway provides visual and acoustic privacy.
- Centre septum above and below raceway overlaid on either side with tackable, 1 1/8" "Sound absorbent mineral board".
- Centre septum below raceway overlaid on either side with 1 1/8" Mineral board.
- Acoustic rating of .80 NRC and 26 STC.
- OPT* = Laminate or Whiteboard.

PRODUCT CODE	PRICE			SIZE / INCHES			WEIGHT VOL	
	GR 1	GR 2	OPT*	H	W	D	LBS	FT ³
BPRA3718	528	543	557	37	18	2.61	18	1.58
BPRA3724	590	604	619	37	24	2.61	21	2.054
BPRA3730	652	661	680	37	30	2.61	25	2.528
BPRA3736	705	754	806	37	36	2.61	28	3.002
BPRA3742	763	814	867	37	42	2.61	32	3.476
BPRA3748	823	870	925	37	48	2.61	35	3.950
BPRA3754	883	931	985	37	54	2.61	39	4.424
BPRA3760	938	988	1041	37	60	2.61	44	4.898
BPRA3766	999	1060	1123	37	66	2.61	50	5.499
BPRA3772	1060	1118	1181	37	72	2.61	56	6.000
BPRA4218	565	592	623	42	18	2.61	22	1.782
BPRA4224	625	654	683	42	24	2.61	28	2.317
BPRA4230	686	714	745	42	30	2.61	32	2.852
BPRA4236	737	794	854	42	36	2.61	36	3.387
BPRA4242	800	856	917	42	42	2.61	40	3.921
BPRA4248	856	915	973	42	48	2.61	44	4.456
BPRA4254	917	973	1034	42	54	2.61	48	4.991
BPRA4260	973	1030	1091	42	60	2.61	52	5.525
BPRA4266	1087	1204	1330	42	66	2.61	62	6.148
BPRA4272	1197	1315	1441	42	72	2.61	72	6.770
BPRA5018	603	630	659	50	18	2.61	25	2.106
BPRA5024	661	707	751	50	24	2.61	30	2.738
BPRA5030	726	773	816	50	30	2.61	35	3.370
BPRA5036	792	864	938	50	36	2.61	40	4.002
BPRA5042	852	922	998	50	42	2.61	45	4.634
BPRA5048	917	987	1063	50	48	2.61	50	5.266
BPRA5054	976	1050	1123	50	54	2.61	55	5.898
BPRA5060	1040	1112	1187	50	60	2.61	60	6.530
BPRA5066	1137	1258	1382	50	66	2.61	70	7.300
BPRA5072	1233	1351	1476	50	72	2.61	80	8.000
BPRA5418	629	657	688	54	18	2.61	27	2.250
BPRA5424	692	734	780	54	24	2.61	32	2.960
BPRA5430	754	796	842	54	30	2.61	37	3.689
BPRA5436	820	905	997	54	36	2.61	42	4.318
BPRA5442	883	966	1060	54	42	2.61	47	4.934
BPRA5448	948	1030	1123	54	48	2.61	52	5.666
BPRA5454	1007	1092	1186	54	54	2.61	59	6.398
BPRA5460	1073	1157	1250	54	60	2.61	62	7.035

BPRA • Acoustical Raceway Panel ...Cont

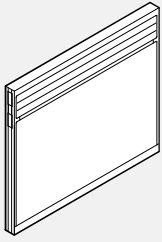

37" High

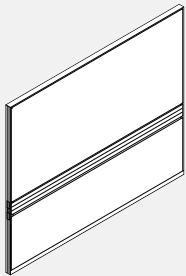
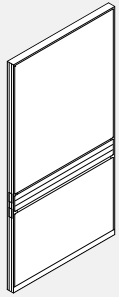

72" Wide

- Fabric above the raceway provides visual and acoustic privacy.
- Centre septum above and below raceway overlaid on either side with tackable, 1 1/8" "Sound absorbent mineral board".
- Centre septum below raceway overlaid on either side with 1 1/8" Mineral board.
- Acoustic rating of .80 NRC and 26 STC.
- OPT* = Laminate or Whiteboard.

PRODUCT CODE	PRICE			SIZE/INCHES			WEIGHT LBS	VOL FT ³
	GR 1	GR 2	OPT*	H	W	D		
BPRA5818	655	683	714	58	18	2.61	28	2.431
BPRA5824	721	762	809	58	24	2.61	33	3.160
BPRA5830	780	823	867	58	30	2.61	38	3.889
BPRA5836	846	930	1023	58	36	2.61	43	4.618
BPRA5842	913	997	1089	58	42	2.61	48	5.347
BPRA5848	975	1061	1153	58	48	2.61	53	6.076
BPRA5854	1040	1125	1216	58	54	2.61	58	6.806
BPRA5860	1106	1189	1283	58	60	2.61	63	7.535
BPRA6618	699	745	788	66	18	2.61	32	2.755
BPRA6624	770	826	886	66	24	2.61	37	3.581
BPRA6630	837	894	955	66	30	2.61	42	4.407
BPRA6636	903	1001	1108	66	36	2.61	48	5.234
BPRA6642	970	1067	1174	66	42	2.61	53	6.060
BPRA6648	1037	1137	1241	66	48	2.61	58	6.887
BPRA6654	1103	1203	1309	66	54	2.61	63	7.713
BPRA6660	1170	1269	1375	66	60	2.61	68	8.539
BPRA7418	759	802	849	74	18	2.61	34	3.079
BPRA7424	826	884	943	74	24	2.61	39	4.002
BPRA7430	894	952	1012	74	30	2.61	45	4.926
BPRA7436	963	1078	1198	74	36	2.61	50	5.850
BPRA7442	1034	1147	1267	74	42	2.61	55	6.773
BPRA7448	1102	1214	1336	74	48	2.61	60	7.697
BPRA7454	1170	1284	1405	74	54	2.61	65	8.620
BPRA7460	1238	1352	1473	74	60	2.61	70	9.544
BPRA8218	823	864	909	82	18	2.61	36	3.403
BPRA8224	893	963	1038	82	24	2.61	42	4.424
BPRA8230	963	1034	1109	82	30	2.61	48	5.444
BPRA8236	1035	1165	1300	82	36	2.61	54	6.465
BPRA8242	1106	1233	1369	82	42	2.61	60	7.486
BPRA8248	1175	1302	1440	82	48	2.61	66	8.507
BPRA8254	1245	1374	1511	82	54	2.61	72	9.528
BPRA8260	1320	1445	1583	82	60	2.61	78	10.549

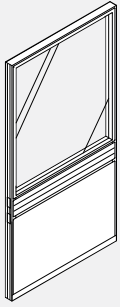
BPRG • Partly Glazed Raceway Panel

- Glazing above the raceway provides visual accessibility.
- Centre septum below raceway overlaid on either side with 1 1/8" "Sound absorbent mineral board".
- Glazing replaceable on site.
- Standard glaze is acrylic.
- For tempered glass, add "TG" to the end of the product code and add 20% to the price regardless of fabric grade or finish.
- OPT* = Laminate or Whiteboard.

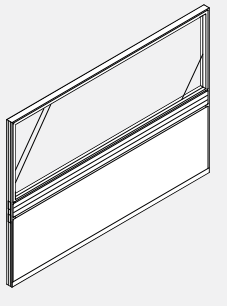

72" Wide

PRODUCT CODE	PRICE			SIZE/INCHES			WEIGHT LBS	VOL FT ³
	GR 1	GR 2	OPT*	H	W	D		
BPRG4218	712	723	740	42	18	2.61	22	1.782
BPRG4224	778	805	835	42	24	2.61	28	2.317
BPRG4230	845	872	903	42	30	2.61	32	2.852
BPRG4236	913	970	1029	42	36	2.61	36	3.387
BPRG4242	976	1034	1094	42	42	2.61	40	3.921
BPRG4248	1045	1102	1165	42	48	2.61	44	4.456
BPRG4254	1112	1169	1231	42	54	2.61	48	4.991
BPRG4260	1177	1235	1296	42	60	2.61	52	5.525
BPRG4266	1244	1303	1369	42	66	2.61	62	6.148
BPRG4272	1312	1370	1436	42	72	2.61	72	6.770
BPRG5018	791	805	820	50	18	2.61	24	2.106
BPRG5024	856	885	916	50	24	2.61	29	2.738
BPRG5030	926	955	985	50	30	2.61	34	3.370
BPRG5036	996	1053	1113	50	36	2.61	39	4.002
BPRG5042	1063	1121	1180	50	42	2.61	44	4.634
BPRG5048	1131	1188	1246	50	48	2.61	48	5.266
BPRG5054	1200	1259	1318	50	54	2.61	54	5.898
BPRG5060	1267	1326	1385	50	60	2.61	59	6.530
BPRG5066	1309	1368	1434	50	66	2.61	70	7.300
BPRG5072	1348	1407	1441	50	72	2.61	78	8.000
BPRG5418	831	846	862	54	18	2.61	27	2.250
BPRG5424	897	928	958	54	24	2.61	30	2.960
BPRG5430	970	998	1028	54	30	2.61	35	3.689
BPRG5436	1040	1096	1157	54	36	2.61	40	4.318
BPRG5442	1109	1168	1227	54	42	2.61	45	4.934
BPRG5448	1177	1235	1296	54	48	2.61	49	5.666
BPRG5454	1246	1304	1367	54	54	2.61	55	6.398
BPRG5460	1318	1375	1436	54	60	2.61	60	7.035
BPRG5818	872	886	901	58	18	2.61	26	2.431
BPRG5824	941	970	999	58	24	2.61	31	3.160
BPRG5830	1012	1040	1069	58	30	2.61	36	3.889
BPRG5836	1086	1142	1201	58	36	2.61	41	4.618
BPRG5842	1156	1212	1273	58	42	2.61	46	5.347
BPRG5848	1225	1283	1343	58	48	2.61	51	6.076
BPRG5854	1296	1352	1412	58	54	2.61	56	6.806
BPRG5860	1367	1424	1483	58	60	2.61	61	7.535
BPRG6618	949	962	976	66	18	2.61	29	2.755
BPRG6624	1023	1052	1083	66	24	2.61	34	3.581
BPRG6630	1096	1126	1156	66	30	2.61	39	4.407
BPRG6636	1171	1231	1290	66	36	2.61	45	5.234
BPRG6642	1245	1303	1366	66	42	2.61	50	6.060
BPRG6648	1324	1379	1440	66	48	2.61	55	6.887
BPRG6654	1396	1454	1514	66	54	2.61	60	7.713
BPRG6660	1475	1534	1594	66	60	2.61	65	8.539
BPRG7418	1024	1037	1053	74	18	2.61	30	3.079
BPRG7424	1103	1132	1165	74	24	2.61	35	4.002
BPRG7430	1181	1238	1300	74	30	2.61	41	4.926
BPRG7436	1261	1318	1378	74	36	2.61	46	5.850
BPRG7442	1339	1396	1457	74	42	2.61	51	6.773
BPRG7448	1419	1476	1539	74	48	2.61	56	7.697
BPRG7454	1498	1554	1615	74	54	2.61	61	8.620
BPRG7460	1590	1647	1710	74	60	2.61	66	9.544
BPRG8218	1079	1091	1107	82	18	2.61	31	3.403
BPRG8224	1168	1197	1226	82	24	2.61	36	4.424
BPRG8230	1259	1288	1317	82	30	2.61	43	5.444
BPRG8236	1348	1406	1466	82	36	2.61	49	6.465
BPRG8242	1435	1491	1550	82	42	2.61	55	7.486
BPRG8248	1526	1583	1644	82	48	2.61	61	8.507
BPRG8254	1613	1670	1731	82	54	2.61	67	9.528
BPRG8260	1714	1774	1832	82	60	2.61	73	10.549

BPRF • Air Flow Panel

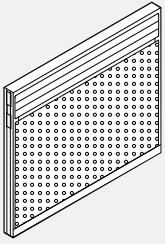

37" High

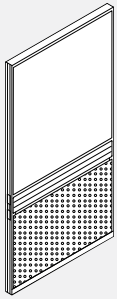

72" Wide

- Double wall of perforated metal below the raceway allows air to flow freely through the bottom of the panel.
- Centre septum above raceway overlaid on either side with tackable, 1 1/8" "Sound absorbent mineral board".
- For air flow option above the raceway, add 20% to the Grade 1 price and tag each item with "air flow above raceway". For example: BPRF4218 TAG:*air flow above raceway.
- OPT* = Laminate or Whiteboard.

PRODUCT CODE	PRICE			SIZE/INCHES			WEIGHT VOL	
	GR 1	GR 2	OPT*	H	W	D	LBS	FT ³
BPRF3718	592	-	-	37	18	2.61	18	1.58
BPRF3724	670	-	-	37	24	2.61	21	2.054
BPRF3730	755	-	-	37	30	2.61	25	2.528
BPRF3736	833	-	-	37	36	2.61	28	3.002
BPRF3742	916	-	-	37	42	2.61	32	3.476
BPRF3748	996	-	-	37	48	2.61	35	3.950
BPRF3754	1074	-	-	37	54	2.61	39	4.424
BPRF3760	1156	-	-	37	60	2.61	44	4.898
BPRF3766	1243	-	-	37	66	2.61	50	5.449
BPRF3772	1330	-	-	37	72	2.61	56	6.000
BPRF4218	612	621	627	42	18	2.61	22	1.782
BPRF4224	694	701	712	42	24	2.61	28	2.317
BPRF4230	778	784	791	42	30	2.61	32	2.852
BPRF4236	860	872	888	42	36	2.61	36	3.387
BPRF4242	943	958	972	42	42	2.61	40	3.921
BPRF4248	1026	1038	1055	42	48	2.61	44	4.456
BPRF4254	1108	1122	1137	42	54	2.61	48	4.991
BPRF4260	1196	1208	1224	42	60	2.61	52	5.525
BPRF4266	1333	1394	1458	42	66	2.61	62	6.270
BPRF4272	1473	1533	1599	42	72	2.61	72	6.770
BPRF5018	688	699	717	50	18	2.61	25	2.106
BPRF5024	773	784	800	50	24	2.61	30	2.738
BPRF5030	857	870	886	50	30	2.61	35	3.370
BPRF5036	947	973	1003	50	36	2.61	40	4.002
BPRF5042	1034	1063	1092	50	42	2.61	45	4.634
BPRF5048	1121	1148	1178	50	48	2.61	50	5.266
BPRF5054	1205	1235	1265	50	54	2.61	55	5.898
BPRF5060	1294	1324	1352	50	60	2.61	60	6.530
BPRF5066	1424	1482	1547	50	66	2.61	70	7.300
BPRF5072	1550	1609	1675	50	72	2.61	80	8.000
BPRF5418	713	733	755	54	18	2.61	27	2.250
BPRF5424	797	819	842	54	24	2.61	32	2.960
BPRF5430	886	908	930	54	30	2.61	37	3.689
BPRF5436	973	1017	1062	54	36	2.61	42	4.318
BPRF5442	1063	1106	1152	54	42	2.61	47	4.934
BPRF5448	1152	1194	1237	54	48	2.61	52	5.666
BPRF5454	1237	1279	1326	54	54	2.61	57	6.398
BPRF5460	1327	1369	1414	54	60	2.61	62	7.035

BPRF • Air Flow Panel ...Cont

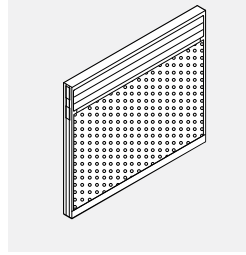

37" High

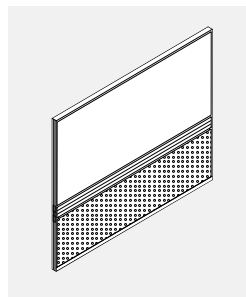
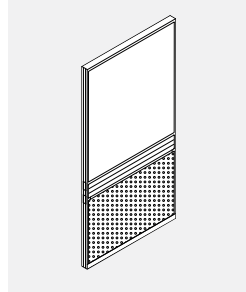

72" Wide

- Double wall of perforated metal below the raceway allows air to flow freely through the bottom of the panel.
- Centre septum above raceway overlaid on either side with tackable, 1 1/8" "Sound absorbent mineral board".
- For air flow option above the raceway, add 20% to the Grade 1 price and tag each item with "air flow above raceway". For example: BPRF4218 TAG:*air flow above raceway.
- OPT* = Laminate or Whiteboard.

PRODUCT CODE	PRICE			SIZE/INCHES			WEIGHT LBS	VOL FT ³
	GR 1	GR 2	OPT*	H	W	D		
BPRF5818	734	755	779	58	18	2.61	28	2.431
BPRF5824	824	845	867	58	24	2.61	33	3.160
BPRF5830	916	936	959	58	30	2.61	38	3.889
BPRF5836	1001	1045	1090	58	36	2.61	43	4.618
BPRF5842	1090	1132	1177	58	42	2.61	48	5.347
BPRF5848	1180	1224	1267	58	48	2.61	53	6.076
BPRF5854	1267	1310	1355	58	54	2.61	58	6.806
BPRF5860	1358	1401	1445	58	60	2.61	63	7.535
BPRF6618	784	813	843	66	18	2.61	32	2.755
BPRF6624	879	907	936	66	24	2.61	37	3.581
BPRF6630	969	997	1027	66	30	2.61	42	4.407
BPRF6636	1060	1108	1160	66	36	2.61	48	5.234
BPRF6642	1212	1264	1317	66	42	2.61	53	6.060
BPRF6648	1288	1336	1389	66	48	2.61	58	6.887
BPRF6654	1395	1443	1498	66	54	2.61	63	7.713
BPRF6660	1435	1483	1538	66	60	2.61	68	8.539
BPRF7418	842	869	898	74	18	2.61	34	3.079
BPRF7424	931	960	992	74	24	2.61	39	4.002
BPRF7430	1026	1055	1086	74	30	2.61	45	4.926
BPRF7436	1121	1193	1266	74	36	2.61	50	5.850
BPRF7442	1294	1366	1440	74	42	2.61	55	6.773
BPRF7448	1332	1405	1480	74	48	2.61	60	7.697
BPRF7454	1397	1470	1543	74	54	2.61	65	8.620
BPRF7460	1491	1563	1638	74	60	2.61	70	9.544
BPRF8218	907	949	995	82	18	2.61	36	3.403
BPRF8224	1000	1043	1089	82	24	2.61	42	4.424
BPRF8230	1094	1137	1181	82	30	2.61	48	5.444
BPRF8236	1201	1279	1363	82	36	2.61	54	6.465
BPRF8242	1332	1411	1496	82	42	2.61	60	7.486
BPRF8248	1395	1473	1556	82	48	2.61	66	8.507
BPRF8254	1543	1622	1706	82	54	2.61	72	9.528
BPRF8260	1575	1654	1738	82	60	2.61	78	10.549

BPRAE • Raceway Panel Electrical

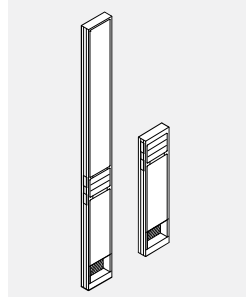

- A 6" raceway panel allows power and communication/data entry along a straight run of panels where a standard post entry cannot be utilized.
- Sections above and below the raceway are upholstered in fabric.
- Inner lower raceway area allows for single or double power feed entry and provides 1.3" x 2.9" opening for communication/data cables.
- All 6" panels must be used in conjunction with a second panel to form a standard panel width. For example: BPRAE6606 + BPRA6618 is equivalent to BPRA6624.
- 6" panels are not to be used as a stability panel in a panel run.

PRODUCT CODE	PRICE			SIZE/ INCHES			WEIGHT LBS	VOL FT ³
	GR 1	GR 2	OPT*	H	W	D		
BPRAE3706	590	605	621	37	6	2.61	24	0.6
BPRAE4206	590	619	652	42	6	2.61	26	0.7
BPRAE5006	661	709	752	50	6	2.61	29	0.8
BPRAE5406	692	736	781	54	6	2.61	31	0.9
BPRAE5806	721	763	811	58	6	2.61	32	0.9
BPRAE6606	770	826	888	66	6	2.61	35	1.0
BPRAE7406	826	884	947	74	6	2.61	37	1.1
BPRAE8206	893	963	1040	82	6	2.61	41	1.2

BPRA • Raceway Panel Filler

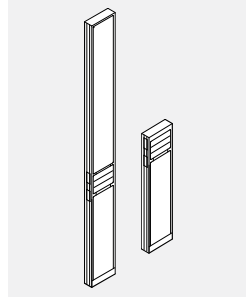

- A 6" (BPRA) raceway panel for use as a filler panel.
- Sections above and below the raceway are upholstered in fabric.
- All 6" panels must be used in conjunction with a second panel to form a standard panel width. For example: BPRA6606 + BPRA6618 is equivalent to BPRA6624.
- 6" panels are not to be used as a stability panel in a panel run.

PRODUCT CODE	PRICE			SIZE/INCHES			WEIGHT LBS	VOL FT ³
	GR 1	GR 2	OPT*	H	W	D		
BPRA3706	590	604	619	37	6	2.61	24	0.6
BPRA4206	590	619	649	42	6	2.61	26	0.7
BPRA5006	661	707	751	50	6	2.61	29	0.8
BPRA5406	692	734	780	54	6	2.61	31	0.9
BPRA5806	721	762	809	58	6	2.61	32	0.9
BPRA6606	770	826	886	66	6	2.61	35	1.0
BPRA7406	826	884	943	74	6	2.61	37	1.1
BPRA8206	893	963	1038	82	6	2.61	41	1.2

BPRP • Pass-Thru Raceway Panel

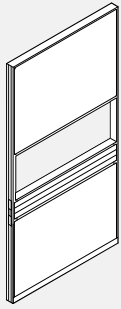

- 10.5" Open cavity allows accessibility between workstations.
- Center septum above 10.5" opening overlaid on either side with tackable, 1 1/8" mineral board.
- Center septum below raceway overlaid on either side with tackable, 1 1/8" mineral board.
- Pass-thru opening is 10.5" high starting above the raceway.
- Panel height to top of opening is fixed.

PRODUCT CODE	PRICE			SIZE/INCHES			WEIGHT LBS	VOL FT ³
	GR 1	GR 2	OPT*	H	W	D		
BPRP6618	949	962	976	66	18	2.61	32	2.755
BPRP6624	1023	1052	1083	66	24	2.61	33	3.581
BPRP6630	1096	1126	1156	66	30	2.61	38	4.407
BPRP6636	1171	1231	1290	66	36	2.61	44	5.234
BPRP6642	1245	1303	1366	66	42	2.61	49	6.060
BPRP6648	1324	1379	1440	66	48	2.61	54	6.887
BPRP6654	1396	1454	1514	66	54	2.61	59	7.713
BPRP6660	1475	1534	1594	66	60	2.61	64	8.539
BPRP7418	1024	1060	1094	74	18	2.61	31	3.079
BPRP7424	1103	1160	1223	74	24	2.61	36	4.002
BPRP7430	1181	1238	1300	74	30	2.61	42	4.926
BPRP7436	1261	1329	1405	74	36	2.61	47	5.850
BPRP7442	1339	1396	1457	74	42	2.61	52	6.773
BPRP7448	1419	1514	1613	74	48	2.61	57	7.697
BPRP7454	1498	1590	1690	74	54	2.61	62	8.620
BPRP7460	1590	1647	1710	74	60	2.61	67	9.544
BPRP8218	1079	1119	1165	82	18	2.61	34	3.403
BPRP8224	1168	1223	1279	82	24	2.61	40	4.424
BPRP8230	1259	1312	1370	82	30	2.61	46	5.444
BPRP8236	1348	1447	1552	82	36	2.61	52	6.465
BPRP8242	1435	1547	1668	82	42	2.61	58	7.486
BPRP8248	1526	1639	1758	82	48	2.61	64	8.507
BPRP8254	1613	1724	1846	82	54	2.61	70	9.528
BPRP8260	1714	1827	1949	82	60	2.61	76	10.549

BPRPSD • Pass-Thru Sliding Door Kit

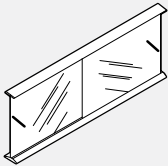

- To close the opening in a Boulevard 1 Pass-Thru Panel.
- Sliding frosted tempered glass doors.

PRODUCT CODE	PRICE	SIZE/INCHES			WEIGHT LBS	VOL FT ³
		H	W	D		
BPRPSD36	385	10	36	2.61	13	1.2
BPRPSD42	433	10	42	2.61	16	1.4
BPRPSD48	483	10	48	2.61	18	1.5
BPRPSD54	528	10	54	2.61	20	1.7
BPRPSD60	578	10	60	2.61	22	2.0

BPAR • Accessory Rail Panel

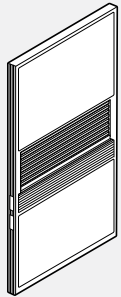

- 12" Accessory rail covers the standard pass-thru opening and allows users to hang accessories.
- Centre septum above 12" opening overlaid on either side with tackable, 1 1/8" "Sound absorbent mineral board".
- Centre septum below raceway overlaid on either side with 1 1/8" mineral board.
- Accessory rail is 12" high starting above the raceway. Panel height to top of opening is fixed.
- OPT* = Laminate or Whiteboard.

PRODUCT CODE	PRICE			SIZE/INCHES			WEIGHT LBS	VOL FT ³
	GR 1	GR 2	OPT*	H	W	D		
BPAR6618	1107	1121	1135	66	18	2.61	35	2.755
BPAR6624	1201	1232	1261	66	24	2.61	42	3.581
BPAR6630	1320	1348	1378	66	30	2.61	49	4.407
BPAR6636	1442	1500	1561	66	36	2.61	57	5.234
BPAR6642	1595	1653	1713	66	42	2.61	65	6.060
BPAR6648	1714	1774	1832	66	48	2.61	72	6.887
BPAR6654	1838	1893	1955	66	54	2.61	79	7.713
BPAR6660	1953	2012	2071	66	60	2.61	86	8.539
BPAR7418	1186	1220	1258	74	18	2.61	38	3.079
BPAR7424	1279	1338	1397	74	24	2.61	45	4.002
BPAR7430	1397	1456	1515	74	30	2.61	53	4.926
BPAR7436	1529	1600	1672	74	36	2.61	60	5.850
BPAR7442	1683	1741	1801	74	42	2.61	68	6.773
BPAR7448	1805	1903	2007	74	48	2.61	75	7.697
BPAR7454	1930	1987	2049	74	54	2.61	82	8.620
BPAR7460	2060	2117	2177	74	60	2.61	89	9.544
BPAR8218	1234	1273	1318	82	18	2.61	41	3.403
BPAR8224	1340	1395	1454	82	24	2.61	49	4.424
BPAR8230	1470	1525	1581	82	30	2.61	57	5.444
BPAR8236	1608	1710	1813	82	36	2.61	65	6.465
BPAR8242	1775	1888	2007	82	42	2.61	74	7.486
BPAR8248	1906	2019	2141	82	48	2.61	82	8.507
BPAR8254	2042	2156	2277	82	54	2.61	90	9.528
BPAR8260	2174	2288	2408	82	60	2.61	98	10.549

BPFA • Acoustical Fabric Panel

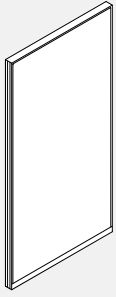

- Complete fabric panel without raceway.
- Acoustical rating of .80 NRC and 26 STC.
- Centre septum overlaid on either side with 1/8" Mineral board, non tackable.
- OPT* = Laminate or Whiteboard.

PRODUCT CODE	PRICE			SIZE / INCHES			WEIGHT LBS	VOL FT ³
	GR 1	GR 2	OPT*	H	W	D		
BPFA2918	364	391	420	29	18	2.61	15	1.256
BPFA2924	392	422	456	29	24	2.61	17	1.633
BPFA2930	419	449	478	29	30	2.61	19	2.009
BPFA2936	450	508	568	29	36	2.61	21	2.386
BPFA2942	477	536	593	29	42	2.61	23	2.763
BPFA2948	508	565	625	29	48	2.61	25	3.139
BPFA2954	536	591	653	29	54	2.61	27	3.513
BPFA2960	563	621	681	29	60	2.61	29	3.893
BPFA2966	582	643	709	29	66	2.61	36	4.332
BPFA2972	604	660	-	29	72	2.61	42	4.770
BPFA4218	477	507	537	42	18	2.61	18	1.782
BPFA4224	509	567	626	42	24	2.61	21	2.317
BPFA4230	539	593	655	42	30	2.61	24	2.852
BPFA4236	569	639	715	42	36	2.61	27	3.387
BPFA4242	600	670	746	42	42	2.61	30	3.921
BPFA4248	629	698	777	42	48	2.61	33	4.456
BPFA4254	658	727	805	42	54	2.61	36	4.991
BPFA4260	691	761	837	42	60	2.61	39	5.525
BPFA4266	779	896	1024	42	66	2.61	47	6.148
BPFA4272	865	985	-	42	72	2.61	54	6.770
BPFA5018	540	568	596	50	18	2.61	22	2.106
BPFA5024	573	613	658	50	24	2.61	25	2.738
BPFA5030	605	647	692	50	30	2.61	28	3.370
BPFA5036	636	722	813	50	36	2.61	31	4.002
BPFA5042	668	752	845	50	42	2.61	34	4.634
BPFA5048	698	784	877	50	48	2.61	38	5.266
BPFA5054	733	817	909	50	54	2.61	41	5.898
BPFA5060	765	851	942	50	60	2.61	43	6.530
BPFA5066	843	962	1089	50	66	2.61	53	7.300
BPFA5072	920	1038	-	50	72	2.61	62	8.000
BPFA5418	570	600	629	54	18	2.61	23	2.250
BPFA5424	604	645	691	54	24	2.61	26	2.960
BPFA5430	636	680	723	54	30	2.61	30	3.689
BPFA5436	670	754	846	54	36	2.61	34	4.318
BPFA5442	701	786	880	54	42	2.61	38	4.934
BPFA5448	736	820	913	54	48	2.61	41	5.666
BPFA5454	770	853	947	54	54	2.61	43	6.398
BPFA5460	805	891	983	54	60	2.61	46	7.035

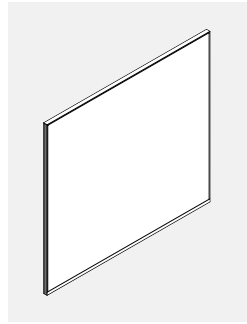

72" Wide

BPFA • Acoustical Fabric Panel ...Cont

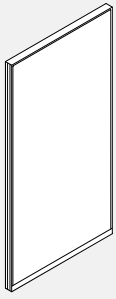

- Complete fabric panel without raceway.
- Acoustical rating of .80 NRC and 26 STC.
- Centre septum overlaid on either side with 1/8" Mineral board, non tackable.
- OPT* = Laminate or Whiteboard.

PRODUCT CODE	PRICE			SIZE/INCHES			WEIGHT LBS	VOL FT ³
	GR 1	GR 2	OPT*	H	W	D		
BPFA5818	602	643	688	58	18	2.61	24	2.431
BPFA5824	634	692	752	58	24	2.61	27	3.160
BPFA5830	668	724	785	58	30	2.61	31	3.889
BPFA5836	699	801	907	58	36	2.61	35	4.618
BPFA5842	736	835	941	58	42	2.61	39	5.347
BPFA5848	773	869	975	58	48	2.61	42	6.076
BPFA5854	805	905	1011	58	54	2.61	46	6.806
BPFA5860	843	942	1050	58	60	2.61	50	7.535
BPFA6618	656	697	745	66	18	2.61	26	2.755
BPFA6624	693	751	812	66	24	2.61	29	3.581
BPFA6630	731	788	850	66	30	2.61	34	4.407
BPFA6636	770	883	1001	66	36	2.61	39	5.234
BPFA6642	809	921	1041	66	42	2.61	43	6.060
BPFA6648	846	959	1080	66	48	2.61	47	6.887
BPFA6654	885	998	1119	66	54	2.61	51	7.713
BPFA6660	921	1034	1155	66	60	2.61	55	8.539
BPFA7418	720	761	806	74	18	2.61	28	3.079
BPFA7424	758	829	905	74	24	2.61	32	4.002
BPFA7430	797	868	943	74	30	2.61	37	4.926
BPFA7436	837	963	1101	74	36	2.61	42	5.850
BPFA7442	879	1003	1142	74	42	2.61	47	6.773
BPFA7448	918	1045	1181	74	48	2.61	51	7.697
BPFA7454	958	1086	1223	74	54	2.61	55	8.620
BPFA7460	999	1126	1264	74	60	2.61	60	9.544
BPFA8218	778	833	894	82	18	2.61	30	3.403
BPFA8224	819	891	964	82	24	2.61	35	4.424
BPFA8230	863	933	1007	82	30	2.61	40	5.444
BPFA8236	907	1050	1199	82	36	2.61	45	6.465
BPFA8242	949	1090	1239	82	42	2.61	50	7.486
BPFA8248	994	1134	1286	82	48	2.61	55	8.507
BPFA8254	1037	1178	1329	82	54	2.61	60	9.528
BPFA8260	1084	1225	1375	82	60	2.61	65	10.549

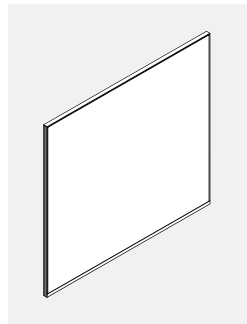

72" Wide

BPFG • Glazed Panel

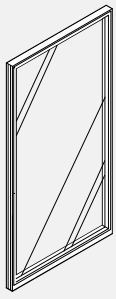

- Full-height glazing provides visual accessibility.
- Glazing is replaceable on site.
- For tempered glass, add "TG" to the end of the product code and 20% to the list price regardless of finish.

PRODUCT CODE	PRICE	SIZE/ INCHES			WEIGHT LBS	VOL FT ³
		H	W	D		
BPFG5824	833	58	24	2.61	21	3.160
BPFG5830	918	58	30	2.61	24	3.889
BPFG5836	1000	58	36	2.61	27	4.618
BPFG5842	1086	58	42	2.61	30	5.347
BPFG5848	1167	58	48	2.61	33	6.076
BPFG6624	1004	66	24	2.61	25	3.581
BPFG6630	1090	66	30	2.61	28	4.407
BPFG6636	1177	66	36	2.61	31	5.234
BPFG6642	1264	66	42	2.61	34	6.060
BPFG6648	1352	66	48	2.61	37	6.887
BPFG7424	1053	74	24	2.61	28	4.002
BPFG7430	1143	74	30	2.61	31	4.926
BPFG7436	1235	74	36	2.61	34	5.850
BPFG7442	1327	74	42	2.61	37	6.773
BPFG7448	1416	74	48	2.61	40	7.697
BPFG8224	1148	82	24	2.61	31	4.424
BPFG8230	1255	82	30	2.61	34	5.444
BPFG8236	1352	82	36	2.61	37	6.465
BPFG8242	1454	82	42	2.61	40	7.486
BPFG8248	1554	82	48	2.61	43	8.507

BPOF • Fabric Over Panel

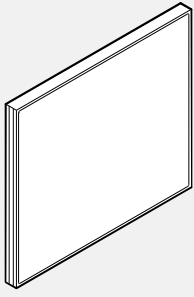

- **Attaches to top of a panel to create floor-to-ceiling wall.**

- Centre septum overlaid on either side with 1 1/8" Mineral board.
- Non-slotted.
- Factory installed PVC strip attaches and aligns over panel to top of base panel.
- PVC strip runs entire width eliminating light seepage.
- For custom heights and widths, please order size required and price as next size up. Example: 26" high, 35" wide, order BPOF2635 at \$473 Grade 1.
- Custom heights over 42" must be quoted separately.
- Overpanels can be stacked on any panel. Example: BPOF2418 stacked on BPRA4218 to give an overall height of 66".
- When stacking on 29" or 37" high B1 panels, custom height required, please contact customer service.
- Exact height should be specified when ordering, with allowance of at least 1" of free space between over panel and ceiling to accommodate height variations in ceiling and floor. Runs of over panels should be captured at either end with full height posts, wall adapters, taller panels, and/or vertical trims.
- Minimum height of 6".
- OPT* = Laminate or Whiteboard.

PRODUCT CODE	PRICE			SIZE / INCHES			WEIGHT LBS	VOL FT ³
	GR 1	GR 2	OPT*	H	W	D		
BPOF0818	182	199	212	8	18	2.61	6	0.351
BPOF0824	212	240	271	8	24	2.61	6	0.468
BPOF0830	252	281	312	8	30	2.61	8	0.730
BPOF0836	293	320	351	8	36	2.61	10	0.912
BPOF0842	323	351	382	8	42	2.61	10	0.912
BPOF0848	364	391	420	8	48	2.61	12	1.094
BPOF0854	406	434	464	8	54	2.61	12	1.094
BPOF0860	434	462	491	8	60	2.61	14	1.277
BPOF0866	473	534	595	8	66	2.61	17	1.549
BPOF0872	509	568	631	08	72	2.61	20	1.820
BPOF1618	241	259	271	16	18	2.61	8	0.730
BPOF1624	274	303	332	16	24	2.61	8	0.730
BPOF1630	313	342	372	16	30	2.61	10	0.912
BPOF1636	353	383	412	16	36	2.61	12	1.094
BPOF1642	385	415	446	16	42	2.61	12	1.094
BPOF1648	425	454	484	16	48	2.61	14	1.277
BPOF1654	465	494	523	16	54	2.61	14	1.277
BPOF1660	495	523	553	16	60	2.61	15	1.368
BPOF1666	521	580	645	16	66	2.61	20	1.774
BPOF1672	574	631	695	16	72	2.61	24	2.180
BPOF2418	333	347	364	24	18	2.61	12	1.094
BPOF2424	361	388	418	24	24	2.61	14	1.422
BPOF2430	389	418	449	24	30	2.61	17	1.750
BPOF2436	417	457	505	24	36	2.61	18	2.078
BPOF2442	446	486	535	24	42	2.61	21	2.406
BPOF2448	475	516	562	24	48	2.61	22	2.734
BPOF2454	501	528	561	24	54	2.61	24	3.063
BPOF2460	528	573	615	24	60	2.61	27	3.391
BPOF2466	569	627	692	24	66	2.61	32	3.766
BPOF2472	607	665	727	24	72	2.61	36	4.140
BPOF3718	378	408	438	37	18	2.61	17	1.580
BPOF3724	410	439	471	37	24	2.61	19	2.054
BPOF3730	441	483	527	37	30	2.61	22	2.528
BPOF3736	473	543	619	37	36	2.61	24	3.006
BPOF3742	501	573	647	37	42	2.61	28	3.476
BPOF3748	535	604	680	37	48	2.61	30	3.950
BPOF3754	563	633	711	37	54	2.61	32	4.424
BPOF3760	592	661	740	37	60	2.61	34	4.898
BPOF3766	661	783	909	37	66	2.61	41	5.449
BPOF3772	733	852	-	37	72	2.61	48	6.000
BPOF4218	477	507	537	42	18	2.61	18	1.780
BPOF4224	509	567	626	42	24	2.61	21	2.310
BPOF4230	539	593	655	42	30	2.61	24	2.850
BPOF4236	569	639	715	42	36	2.61	27	3.390
BPOF4242	600	670	746	42	42	2.61	30	3.920
BPOF4248	630	699	778	42	48	2.61	33	4.460
BPOF4254	658	727	805	42	54	2.61	36	4.990
BPOF4260	691	761	837	42	60	2.61	39	5.250
BPOF4266	774	892	1018	42	66	2.61	47	6.015
BPOF4272	853	972	-	42	72	2.61	54	6.780

BPOG • Glazed Over Panel

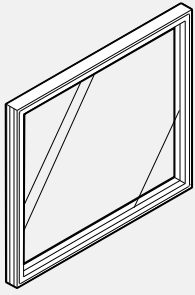

- **Attaches to top of a panel to create floor-to-ceiling wall.**
- Non-slotted.
- Factory installed PVC strip attaches and aligns over panel to top of base panel.
- PVC strip runs entire width eliminating light seepage.
- For custom heights and widths, order size required and price as next size up. Example: 26" high, 35" wide, order BPOG2635 at \$639 in acrylic.
- Custom heights over 42" must be quoted separately.
- Over panels can be stacked on any panel. Example: BPOG2418 stacked on BPRA4218 to give an overall height of 66".
- When stacking on 29" or 37" high B1 panels, custom height required, please contact customer service.
- Exact height should be specified when ordering, with allowance of at least 1" of free space between over panel and ceiling to accommodate height variations in ceiling and floor. Runs of over panels should be captured at either end with full height posts, wall adapters, taller panels, and/or vertical trims.
- Minimum height of 6".
- For tempered glass option, add "TG" to the end of the product code and 20% to the list price.

PRODUCT CODE	PRICE	SIZE/ INCHES			WEIGHT LBS	VOL FT ³
		H	W	D		
BPOG0818	122	8	18	2.61	6	0.351
BPOG0824	151	8	24	2.61	6	0.468
BPOG0830	182	8	30	2.61	8	0.730
BPOG0836	211	8	36	2.61	10	0.912
BPOG0842	241	8	42	2.61	10	0.912
BPOG0848	275	8	48	2.61	12	1.094
BPOG0854	305	8	54	2.61	12	1.094
BPOG0860	336	8	60	2.61	14	1.277
BPOG0866	354	8	66	2.61	17	1.549
BPOG0872	375	8	72	2.61	20	1.820
BPOG1618	194	16	18	2.61	8	0.730
BPOG1624	234	16	24	2.61	8	0.730
BPOG1630	275	16	30	2.61	10	0.912
BPOG1636	323	16	36	2.61	12	1.094
BPOG1642	353	16	42	2.61	12	1.094
BPOG1648	394	16	48	2.61	14	1.277
BPOG1654	434	16	54	2.61	14	1.277
BPOG1660	476	16	60	2.61	15	1.368
BPOG1666	495	16	66	2.61	20	1.774
BPOG1672	516	16	72	2.61	24	2.180
BPOG2418	344	24	18	2.61	12	1.094
BPOG2424	389	24	24	2.61	14	1.422
BPOG2430	432	24	30	2.61	17	1.750
BPOG2436	475	24	36	2.61	18	2.078
BPOG2442	516	24	42	2.61	21	2.406
BPOG2448	561	24	48	2.61	22	2.734
BPOG2454	602	24	54	2.61	24	3.063
BPOG2460	641	24	60	2.61	27	3.391
BPOG2466	699	24	66	2.61	32	3.766
BPOG2472	761	24	72	2.61	36	4.140
BPOG3718	494	37	18	2.61	17	1.580
BPOG3724	543	37	24	2.61	19	2.054
BPOG3730	593	37	30	2.61	22	2.528
BPOG3736	639	37	36	2.61	24	3.006
BPOG3742	691	37	42	2.61	28	3.476
BPOG3748	736	37	48	2.61	30	3.950
BPOG3754	786	37	54	2.61	32	4.424
BPOG3760	833	37	60	2.61	34	4.898
BPOG3766	872	37	66	2.61	41	5.449
BPOG3772	913	37	72	2.61	48	6.000
BPOG4218	523	42	18	2.61	18	1.780
BPOG4224	577	42	24	2.61	21	2.310
BPOG4230	630	42	30	2.61	24	2.850
BPOG4236	678	42	36	2.61	27	3.390
BPOG4242	736	42	42	2.61	30	3.920
BPOG4248	786	42	48	2.61	33	4.460
BPOG4254	833	42	54	2.61	36	4.990
BPOG4260	886	42	60	2.61	39	5.250
BPOG4266	931	42	66	2.61	47	6.015
BPOG4272	976	42	72	2.61	54	6.780

BAPAS • Glass Over Panel with Round Pucks for Boulevard 1

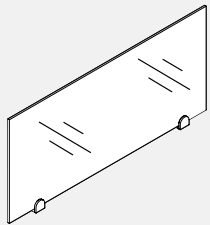

- **Glass Over Panel creates division.**
- Glass Over Panel with no frame sits on top of a Boulevard 1 Panel with clamps that are secured to the top of the panel.
- Tempered glass is 16" high.
- Custom sizes available, contact your Customer Service Representative.
- For application where the over panel is sandwiched between two taller panels, please request a special as the glass will not fit due to trims.

PRODUCT CODE	PRICE CLR	FRST	SIZE/INCHES			WEIGHT LBS	VOL FT ³
			H	W	D		
BAPAS0824	204	235	8	24	1.3	4	0.22
BAPAS0830	229	262	8	30	1.3	5	0.30
BAPAS0836	241	283	8	36	1.3	6	0.37
BAPAS0842	262	306	8	42	1.3	7	0.43
BAPAS0848	281	323	8	48	1.3	8	0.48
BAPAS1624	218	248	16	24	1.3	8	0.44
BAPAS1630	241	276	16	30	1.3	10	0.59
BAPAS1636	260	299	16	36	1.3	12	0.73
BAPAS1642	276	320	16	42	1.3	14	0.85
BAPAS1648	281	339	16	48	1.3	16	0.96

BAPASS • Glass Over Panel with Square Pucks for Boulevard 1

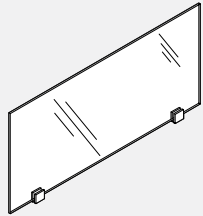

- **Glass Over Panel creates division.**
- Glass Over Panel with no frame sits on top of a Boulevard 1 Panel with clamps that are secured to the top of the panel.
- Tempered glass is 16" high.
- Custom sizes available, contact your Customer Service Representative.
- For application where the over panel is sandwiched between two taller panels, please request a special as the glass will not fit due to trims.

PRODUCT CODE	PRICE		SIZE/INCHES			WEIGHT VOL	
	CLR	FRST	H	W	D	LBS	FT ³
BAPASS0824	218	248	8	24	1.3	4	0.22
BAPASS0830	241	276	8	30	1.3	5	0.30
BAPASS0836	262	299	8	36	1.3	6	0.37
BAPASS0842	276	320	8	42	1.3	7	0.43
BAPASS0848	298	339	8	48	1.3	8	0.48
BAPASS1624	235	264	16	24	1.3	8	0.44
BAPASS1630	260	291	16	30	1.3	10	0.59
BAPASS1636	274	313	16	36	1.3	12	0.73
BAPASS1642	291	338	16	42	1.3	14	0.85
BAPASS1648	299	352	16	48	1.3	16	0.96

BAPAST • Felt Over Panel with Round Pucks for Boulevard 1

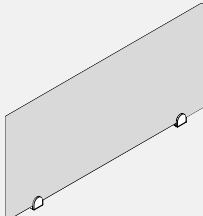

- **Felt Over Panel creates division.**
- Felt Over Panel with no frame sits on top of a Boulevard 1 panel with round clamps that are secured to the top of the panel.
- Felt panel is 8" and 16" high.
- Felt is 9mm thick, please choose from our standard 18 finishes.
- For application where the over panel is sandwiched between two taller panels, please request a special as the glass will not fit due to trims.

PRODUCT CODE	PRICE	SIZE/INCHES			WEIGHT VOL	
		H	W	D	LBS	FT ³
BAPAST0824	103	8	22.7	1.13	1.0	0.11
BAPAST0830	110	8	28.7	1.13	1.1	0.14
BAPAST0836	117	8	34.7	1.13	1.2	0.17
BAPAST0842	129	8	40.7	1.13	1.3	0.20
BAPAST0848	139	8	46.7	1.13	1.4	0.23
BAPAST1624	132	16	22.7	1.13	1.4	0.23
BAPAST1630	148	16	28.7	1.13	1.5	0.29
BAPAST1636	170	16	34.7	1.13	1.7	0.35
BAPAST1642	183	16	40.7	1.13	1.9	0.42
BAPAST1648	197	16	46.7	1.13	2.0	0.48

BAPASST • Felt Over Panel with Square Pucks for Boulevard 1

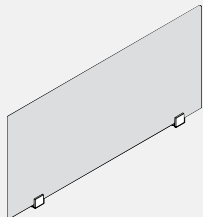

- **Felt Over Panel creates division.**
- Felt Over Panel with no frame sits on top of a Boulevard 1 panel with round clamps that are secured to the top of the panel.
- Felt panel is 8" and 16" high.
- Felt is 9mm thick, please choose from our standard 18 finishes.
- For application where the over panel is sandwiched between two taller panels, please request a special as the glass will not fit due to trims.

PRODUCT CODE	PRICE	SIZE/INCHES			WEIGHT VOL	
		H	W	D	LBS	FT ³
BAPASST0824	103	8	22.7	1.13	1.0	0.11
BAPASST0830	110	8	28.7	1.13	1.1	0.14
BAPASST0836	117	8	34.7	1.13	1.2	0.17
BAPASST0842	129	8	40.7	1.13	1.3	0.20
BAPASST0848	139	8	46.7	1.13	1.4	0.23
BAPASST1624	132	16	22.7	1.13	1.4	0.23
BAPASST1630	148	16	28.7	1.13	1.5	0.29
BAPASST1636	170	16	34.7	1.13	1.7	0.35
BAPASST1642	183	16	40.7	1.13	1.9	0.42
BAPASST1648	197	16	46.7	1.13	2.0	0.48

BPDS • Solid Door Panel

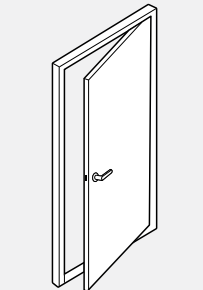

- **Aluminum frame with high pressure laminate.**
- 1 3/8" thick hollow core door.
- Actual door size:
80" x 32 1/2" in 82" x 36" frame
80" x 38 1/2" in 82" x 42" frame
- 42" wide Door Panel permits wheelchair accessibility.
- No hang-on capabilities.
- Non slotted frame.
- 180 degree swing.
- Specify Door Knob (DL01) or Door Lever (DL02).
- Lock standard.
- Handedness can be changed on site.
- Please specify Right hand (R) or Left hand (L) hung.

PRODUCT CODE	PRICE HP	SIZE/INCHES			WEIGHT VOL	
		H	W	D	LBS	FT ³
BPDS8236R	2331	82	36	2.61	61	6.465
BPDS8242R	2539	82	42	2.61	68	7.486
BPDS8236L	2331	82	36	2.61	61	6.465
BPDS8242L	2539	82	42	2.61	68	7.486

Door Hanging Directions

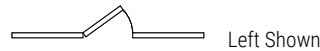

Door Handle Option

Door Knob - DL01
• Lock Standard



Door Lever - DL02(Default)

• Lock Standard
• Lever complies with all accessibility standards



BPDH • Half Glazed Door Panel

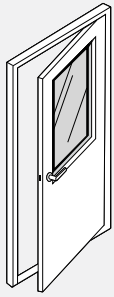

- **Aluminum frame with high pressure laminate door and window.**
- 1 3/8" thick hollow core door.
- Actual door size:
80" x 32 1/2" in 82" x 36" frame
80"x381/2" in 82"x42" frame
- 42" wide Door Panel permits wheelchair accessibility.
- No hang-on capabilities.
- 180 degree swing.
- Specify Door Knob (DL01) or Door Lever (DL02).
- Lock standard.
- Handedness can be changed on site.
- Please specify Right hand (R) or Left hand (L) hung.
- For tempered glass option, add "TG" at the end of the product code and add an upcharge of \$149 for 36" wide doors and \$179 for 42" wide doors.

PRODUCT CODE	PRICE HP	SIZE/INCHES			WEIGHT VOL	
		H	W	D	LBS	FT ³
BPDH8236R	2891	82	36	2.61	53	6.465
BPDH8242R	3160	82	42	2.61	59	7.486
BPDH8236L	2891	82	36	2.61	53	6.465
BPDH8242L	3160	82	42	2.61	59	7.486

Door Hanging Directions

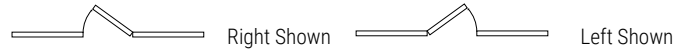

Door Handle Option

- Door Knob - DL01
- Lock Standard
- Door Lever - DL02(Default)
- Lock Standard
- Lever complies with all accessibility standards



BPDG • Solid Glazed Door Panel

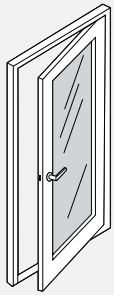

- **Aluminum frame with either high pressure laminate door and window.**
- 1 3/8" thick hollow core door.
- Actual door size:
80" x 32 1/2" in 82" x 36" frame
80"x381/2" in 82"x42" frame
- 42" wide Door Panel permits wheelchair accessibility.
- No hang-on capabilities.
- 180 degree swing.
- Specify Door Knob (DL01) or Door Lever (DL02).
- Lock standard.
- Handedness can be changed on site.
- Please specify Right hand (R) or Left hand (L) hung.
- For tempered glass option, add "TG" at the end of the product code and add an upcharge of \$302 for 36" wide doors and \$376 for 42" wide doors.
- Laminate frame is 5" thick on sides and 4" at top and bottom.

PRODUCT CODE	PRICE HP	SIZE/INCHES			WEIGHT VOL	
		H	W	D	LBS	FT ³
BPDG8236R	3324	82	36	2.61	53	6.465
BPDG8242R	3637	82	42	2.61	59	7.486
BPDG8236L	3324	82	36	2.61	53	6.465
BPDG8242L	3637	82	42	2.61	59	7.486

Door Hanging Directions

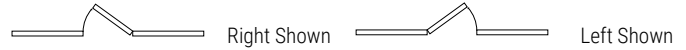

Door Handle Option

- Door Knob - DL01
- Lock Standard
- Door Lever - DL02(Default)
- Lock Standard
- Lever complies with all accessibility standards



BPDSL • Privacy Screen

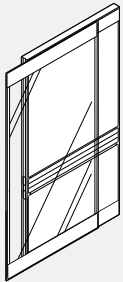

- **Provides territorial privacy in an open plan environment.**
- Lightweight, panel mounted sliding partition.
- Consists of translucent textured polycarbonate.
- Must be mounted to a straight panel of the same size.
- The face of the Privacy Screen sits 3" away from the face of the panel to which it is attached.
- Cable lay-in modules, wood trim and non-load bearing panels may be applied to the top of a panel to which the screen is attached, but not the screen itself.
- When open, the screen may interfere with access doors that open on the outside of an adjacent panel.
- Must specify left or right for the direction in which the door will slide once installed.
- Caps located on the end of the frame default to the panel frame colour.
- All hardware included.
- Can be mounted on Boulevard 1 or Boulevard System 3 panels of the same width as the Privacy Screen.
- Note: Specify left or right for the direction in which the door will slide as per examples above.

PRODUCT CODE	PRICE	SIZE/ INCHES			WEIGHT VOL	
		H	W	D	LBS	FT ³
BPDSL6636R	1981	66	36	2.61	35	5.98
BPDSL6642R	2132	66	42	2.61	42	6.93
BPDSL8136R	2377	81	36	2.61	43	7.30
BPDSL8142R	2551	81	42	2.61	50	8.45
BPDSL6636L	1981	66	36	2.61	35	5.98
BPDSL6642L	2132	66	42	2.61	42	6.93
BPDSL8136L	2377	81	36	2.61	43	7.30
BPDSL8142L	2551	81	42	2.61	50	8.45

Left Hang Option

Right Hang Hung

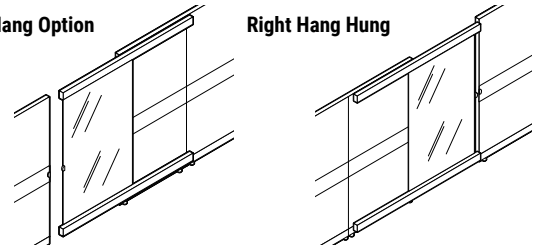

BPDSLLOCK • Privacy Screen Lock

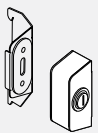

Left Hand Shown

- Lock bracket attaches to Privacy Screen with screws
- Includes strike plate bracket which attaches to slots in connector.
- Lock included.
- Available in tungsten only.
- Requires on site installation, drilling into the Privacy Screen aluminum frame.

PRODUCT CODE	PRICE	SIZE/ INCHES			WEIGHT VOL	
		H	W	D	LBS	FT ³
BPDSLLOCKR	240	2.65	1.2	0.9	1	0.2
BPDSLLOCKL	240	2.65	1.2	0.9	1	0.2

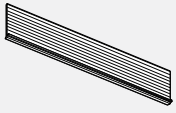
BPXCF • Ceiling Filler

- Durable PVC designed to seal a gap between ceiling and over panel.
- Available in lengths of 124" to be pressed into over panel's horizontal wing profile.
- Can be applied during installation or retrofitted later.
- For use only with Boulevard 1 panels.

PRODUCT CODE	PRICE	SIZE/INCHES			WEIGHT VOL	
		H	W	D	LBS	FT ³
BPXCF124	65	3.25	124	0.125	1	1.2

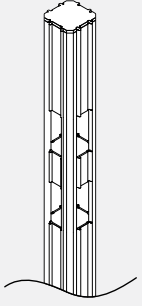
BHP • 90 Degree Post

- Enables connection for multiple panel runs such as 90 degree, 3 way and 4 way.
- Includes 2 "Capture Strip" panel connectors, 4 end strips, 4 pairs of raceway end caps, and 1 post cap.
- Posts are designed to accept the following:
 - 75 cables 5.6mm (0.220") diameter
 - 60 cables 5.6mm (0.220") diameter with 1 powerfeed
 - 45 cables 5.6mm (0.220") diameter with 2 powerfeeds

PRODUCT CODE	PRICE	SIZE/INCHES			WEIGHT VOL	
		H	W	D	LBS	FT ³
BHP029	81	29	2.61	2.61	4	0.154
BHP037	132	37	2.61	2.61	5	0.195
BHP042	145	42	2.61	2.61	5	0.221
BHP050	162	50	2.61	2.61	6	0.263
BHP054	170	54	2.61	2.61	6	0.284
BHP058	178	58	2.61	2.61	7	0.305
BHP066	195	66	2.61	2.61	8	0.346
BHP074	211	74	2.61	2.61	9	0.388
BHP082	228	82	2.61	2.61	9	0.430
BHP106	272	106	2.61	2.61	12	0.560
BHP119	291	119	2.61	2.61	13	0.622

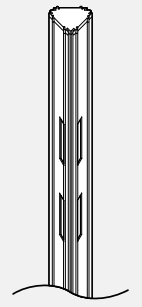
BHP45 • 45 Degree Post

- Enables connection for two panels at 45 degrees.
- Includes 2 "Capture Strip" panel connectors, 4 end strips, 2 pairs of raceway end caps, and 1 post cap.
- 45 degree post does not accept PVC or Wood End Trim.
- No power infeed/post extension capabilities.
- Posts are designed to accept 30 cables 5.6mm (0.220") diameter

PRODUCT CODE	PRICE	SIZE/INCHES			WEIGHT VOL	
		H	W	D	LBS	FT ³
BHP4529	81	29	2.61	2.61	4	0.154
BHP4537	132	37	2.61	2.61	5	0.195
BHP4542	145	42	2.61	2.61	5	0.221
BHP4550	162	50	2.61	2.61	6	0.263
BHP4554	170	54	2.61	2.61	6	0.284
BHP4558	178	58	2.61	2.61	7	0.305
BHP4566	195	66	2.61	2.61	8	0.346
BHP4574	211	74	2.61	2.61	9	0.388
BHP4582	228	82	2.61	2.61	9	0.430
BHP45106	272	106	2.61	2.61	12	0.560
BHP45119	291	119	2.61	2.61	13	0.622

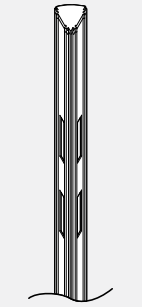
BHP60 • 60 Degree Post

- Enables connection for multiple panel runs such as 120 degrees and 3 way.
- Includes 2 "Capture Strip" panel connectors, 4 end strips, 3 pair of raceway end caps, and 1 post cap.
- No power infeed/post extension capabilities.

PRODUCT CODE	PRICE	SIZE/INCHES			WEIGHT VOL	
		H	W	D	LBS	FT ³
BHP6029	81	29	2.61	2.61	4	0.154
BHP6037	132	37	2.61	2.61	5	0.195
BHP6042	145	42	2.61	2.61	5	0.221
BHP6050	162	50	2.61	2.61	6	0.263
BHP6054	170	54	2.61	2.61	6	0.284
BHP6058	178	58	2.61	2.61	7	0.305
BHP6066	195	66	2.61	2.61	8	0.346
BHP6074	211	74	2.61	2.61	9	0.388
BHP6082	228	82	2.61	2.61	9	0.430
BHP60106	272	106	2.61	2.61	12	0.560
BHP60119	291	119	2.61	2.61	13	0.622

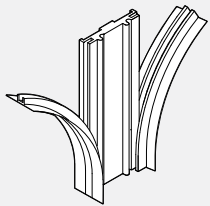
BHWA • Wall Adapter

- Starts a run of panels off an existing wall.
- Includes 2 "Capture Strip" panel connectors and 1 pair of raceway end caps.
- Mounting hardware not included. The mounting hardware selected must be based on the wall or wall stud material.
- Wall adapter adds 5/16" to a panel run.

PRODUCT CODE	PRICE	SIZE/INCHES			WEIGHT VOL	
		H	W	D	LBS	FT ³
BHWA029	57	29	2.61	0.375	4	0.01
BHWA037	60	37	2.61	0.375	5	0.013
BHWA042	64	42	2.61	0.375	5	0.015
BHWA050	68	50	2.61	0.375	6	0.018
BHWA054	72	54	2.61	0.375	6	0.020
BHWA058	74	58	2.61	0.375	7	0.021
BHWA066	80	66	2.61	0.375	8	0.024
BHWA074	90	74	2.61	0.375	9	0.027
BHWA082	93	82	2.61	0.375	9	0.030
BHWA106	119	106	2.61	0.375	12	0.039
BHWA119	137	119	2.61	0.375	13	0.043

BHWASL • Adapter Sleeve

- **Wall Adapter Sleeve is attached to the building to provide flexible support to a panel run.**
- As opposed to the BHWA wall adapter, which connects to the panels securely to a wall, B1 and B3 Boulevard panels rest inside the vertical "U" channel, providing up to 3.5" of flexible adjustment.
- For panel runs taller than 66" order two Wall Adapter Sleeve and either have them cut short on site below the ceiling, or cut a rectangular hole in the ceiling tile. Rectangular slots in the Channels correspond to 66", 58", 50" and 42" high B1 and B3 panels.
- Powder coated steel; specify metal finish.
- Note: the Wall Adapter Sleeve provides flexible, connection, blocks vertical 1" increment clots and cannot, therefore, be used to support overheads and worksurfaces, they must be supported by perpendicular panels, c-legs or gables.
- Note: No fasteners are provided with the Wall Adapter Sleeve. Select the appropriate fasteners according to a structurally wall type.
- Cannot be used to support a door or panel and cannot be used with laminate, airflow or metal skin panels.

PRODUCT CODE	PRICE	SIZE/ INCHES			WEIGHT VOL	
		H	W	D	LBS	FT ³
BHWASL42	149	34.7	4	2	2.5	0.161
BHWASL50	162	42.7	4	2	3.6	0.198
BHWASL54	170	46.7	4	2	4.2	0.220
BHWASL58	174	50.7	4	2	5.1	0.244
BHWASL66	187	58.7	4	2	6.0	0.272

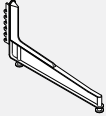
BHHF • High Profile Foot

- **Provides added support to panel under load.**
- Adjustable glides included.
- Made of cast aluminum and cold rolled steel.
- Cannot be used with System 3 Panels

PRODUCT CODE	PRICE	SIZE/INCHES			WEIGHT VOL	
		H	W	D	LBS	FT ³
BHHF01	229	9	1	18.375	4	0.130

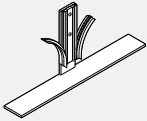
BHLF • Low Profile Foot

- **Stabilizes a run of panels.**
- Attaches with supplied connectors to an end of a panel.
- Made of cold rolled steel.
- Cannot be used with System 3 Panels

PRODUCT CODE	PRICE	SIZE/ INCHES			WEIGHT VOL	
		H	W	D	LBS	FT ³
BHLF01	54	6	9	2.5	7	0.230

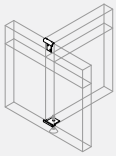
BHPA • Panel to Panel Adapter

- **Enables mid panel, off-module connection.**
- Slim profile.
- Formed steel construction.
- Permanent clamps fit around base channel and fits to top rail.
- Priced as a complete kit.
- Designed for use with Boulevard 1 panels of the same height only.
- Not to be used on the panel seam, with over panels or laminate and metal faced panels.

PRODUCT CODE	PRICE	SIZE/ INCHES			WEIGHT VOL	
		H	W	D	LBS	FT ³
BHPA02	54	2	2.5	00.0	0.25	0.120

BHCS • Capture Strip Slot Cover

- **An extruded PVC channel to adjoin two panels or a panel to a post. Runs the full length of the panel on both sides providing a positive connection of the "Knuckle-Loc" design.**
- Priced per pair.
- Pliable side membranes cover panel slots.
- Included with panel components.
- Only to be ordered separately if required.

PRODUCT CODE	PRICE	SIZE/ INCHES			WEIGHT VOL	
		H	INCHES		LBS	FT ³
BHCS29	12	29			0.21	0.09
BHCS37	13	37			0.24	0.11
BHCS42	13	42			0.28	0.13
BHCS50	14	50			0.33	0.15
BHCS54	14	54			0.31	0.17
BHCS58	16	58			0.63	0.19
BHCS66	21	66			0.40	0.19
BHCS74	22	74			0.43	0.20
BHCS82	24	82			0.47	0.20

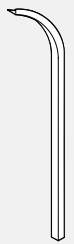
BHCE • End Strip Slot Cover

- **End strips with pliable side membrane covers panel slots at end of run.**
- Priced per pair.
- Included with panel components.
- Only to be ordered separately if required.

PRODUCT CODE	PRICE	SIZE/ INCHES			WEIGHT VOL	
		H	INCHES		LBS	FT ³
BHCE29	11	29			0.10	0.04
BHCE37	12	37			0.12	0.05
BHCE42	12	42			0.14	0.06
BHCE50	13	50			0.16	0.07
BHCE54	13	54			0.31	0.08
BHCE58	13	58			0.18	0.08
BHCE66	14	66			0.20	0.09
BHCE74	16	74			0.22	0.10
BHCE82	21	82			0.23	0.11

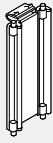
BHRC • Raceway End Cap

- Provides clean detail at the end of a panel run or post. End caps fit flush into communication and power channel entry.
- Priced per pair.
- Made of injection molded ABS.
- Included with panel components. Only to be ordered separately if required.

PRODUCT CODE	PRICE	SIZE/ INCHES			WEIGHT VOL	
		H	W	D	LBS	FT ³
BHRC02	10	3	2.61	0.5	0.04	0.02

BVTE • Vertical End PVC Trim

- Provides a rounded finished detail to the end of the panel run, or a post.
- Includes 2 "Capture Strip" panel connectors and 1 injection molded top cap.
- The PVC end trim is designed to snap at the end of the panel or post.
- Site installed.

PRODUCT CODE	PRICE	SIZE/ INCHES			WEIGHT VOL	
		H	W	D	LBS	FT ³
BVTE37	42	37	2.61	0.25	0.41	0.065
BVTE42	49	42	2.61	0.25	0.48	0.074
BVTE50	56	50	2.61	0.25	0.57	0.088
BVTE54	70	54	2.61	0.25	0.62	0.095
BVTE58	77	58	2.61	0.25	0.66	0.102
BVTE66	80	66	2.61	0.25	0.75	0.115
BVTE74	85	74	2.61	0.25	0.84	0.013
BVTE82	92	82	2.61	0.25	0.93	0.143

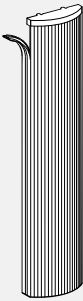
BVTS • Vertical Step Down PVC Trim

- Provides a rounded finished detail to the end of the panel run where two different height panels are specified.
- Includes 2 "Capture Strip" panel connectors and 1 injection molded top cap.
- The PVC end trim is designed to snap at the end of the panel or post.
- Site installed.
- Please specify panels to be used when ordering a 29" step (BVTS29).

PRODUCT CODE	PRICE	SIZE/ INCHES			WEIGHT VOL	
		H	W	D	LBS	FT ³
BVTS04	12	4	2.61	0.25	0.05	0.010
BVTS08	14	8	2.61	0.25	0.09	0.015
BVTS12	21	12	2.61	0.25	0.12	0.021
BVTS16	29	16	2.61	0.25	0.18	0.029
BVTS20	31	20	2.61	0.25	0.20	0.035
BVTS24	34	24	2.61	0.25	0.27	0.043
BVTS32	38	32	2.61	0.25	0.36	0.056
BVTS38	45	38	2.61	0.25	0.45	0.067
BVTS40	47	40	2.61	0.25	0.45	0.070
BVTS48	55	48	2.61	0.25	0.54	0.084
BVTS56	65	56	2.61	0.25	0.63	0.098

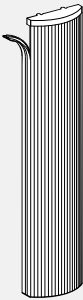
BVTS • Vertical Step Down PVC Trim for 37" High Panels

- Provides a finished detail to the end of the panel run that sits next to a 37" high panel. This PVC trim will bridge the distance between the 37" and higher panel.
- Includes 2 "Capture Strip" panel connectors and 1 injection molded top cap.
- The PVC end trim is designed to snap at the end of the panel or post.
- Site installed.
- Please specify panels to be used when ordering a 29" step (BVTS29).

PRODUCT CODE	PRICE	SIZE/ INCHES			WEIGHT VOL	
		H	W	D	LBS	FT ³
BVTS05	12	5	2.61	0.25	0.06	0.015
BVTS13	21	13	2.61	0.25	0.15	0.029
BVTS17	30	17	2.61	0.25	0.15	0.035
BVTS21	32	21	2.61	0.25	0.24	0.043
BVTS29	35	29	2.61	0.25	0.33	0.051
BVTS37	44	37	2.61	0.25	0.41	0.067
BVTS45	48	45	2.61	0.25	0.51	0.084

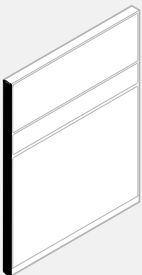
BAVTE • Aluminum Vertical End Round Trim

- Provides a finished detail to the end of a panel run.
- Aluminum radiused front section and injection molded top cap.
- Includes 2 "Capture Strip" panel connectors and 1 injection molded top cap.
- The Aluminum End Trim is designed to snap at the end of the panel or post.
- Site installed.
- BAVTE119 cannot ship via courier and must be combined with other product.

PRODUCT CODE	PRICE	SIZE/ INCHES			WEIGHT VOL	
		H	W	D	LBS	FT ³
BAVTE37	44	37	2.61	0.125	1.2	0.03
BAVTE42	49	42	2.61	0.125	1.4	0.03
BAVTE50	56	50	2.61	0.125	1.7	0.04
BAVTE54	70	54	2.61	0.125	1.8	0.04
BAVTE58	77	58	2.61	0.125	1.9	0.04
BAVTE66	80	66	2.61	0.125	2.2	0.05
BAVTE74	85	74	2.61	0.125	2.4	0.05
BAVTE82	92	82	2.61	0.125	2.7	0.06
BAVTE119	137	119	2.61	0.125	3.9	0.08

BAVTS • Aluminum Vertical End Round Trim - Standard Step Down

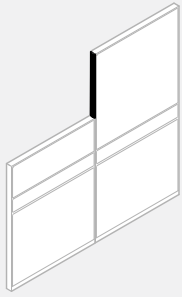

- Provides a finished detail to the end of a panel run where two different height panels are specified.
- Aluminum radiused front section and injection molded top cap.
- Includes 2 "Capture Strip" panel connectors and 1 injection molded top cap.
- The Aluminum End Trim is designed to snap at the end of the panel or post.
- Site installed.
- Specify panels to be used when ordering a 29" step.

PRODUCT CODE	PRICE	SIZE/ INCHES			WEIGHT VOL	
		H	W	D	LBS	FT ³
BAVTS04	12	4	2.61	0.125	0.2	0.01
BAVTS08	14	8	2.61	0.125	0.3	0.02
BAVTS12	21	12	2.61	0.125	0.4	0.02
BAVTS16	29	16	2.61	0.125	0.5	0.03
BAVTS20	31	20	2.61	0.125	0.7	0.04
BAVTS24	34	24	2.61	0.125	0.8	0.04
BAVTS32	38	32	2.61	0.125	1.1	0.06
BAVTS38	45	38	2.61	0.125	1.3	0.07
BAVTS40	46	40	2.61	0.125	1.3	0.07
BAVTS48	55	48	2.61	0.125	1.6	0.08
BAVTS56	65	56	2.61	0.125	1.8	0.10

BAVTSF • Aluminum Vertical End Round Trim - Step Down for 37" High Panels

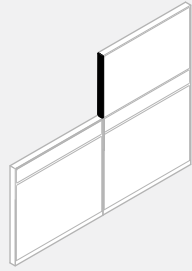

- Provides a finished detail to the end of a panel run adjacent to a 37" high panel.
- Aluminum radiused front section and injection molded top cap.
- Includes 2 "Capture Strip" panel connectors and 1 injection molded top cap.
- The Aluminum End Trim is designed to snap at the end of the panel or post.
- Site installed.

PRODUCT CODE	PRICE	SIZE/ INCHES			WEIGHT VOL	
		H	W	D	LBS	FT ³
BAVTSF05	13	5	2.61	0.125	0.2	0.02
BAVTSF13	22	13	2.61	0.125	0.4	0.03
BAVTSF17	30	17	2.61	0.125	0.6	0.04
BAVTSF21	32	21	2.61	0.125	0.7	0.04
BAVTSF29	35	29	2.61	0.125	1.0	0.05
BAVTSF37	44	37	2.61	0.125	1.2	0.07
BAVTSF45	53	45	2.61	0.125	1.5	0.08

BARC • Aluminum Raceway Cover

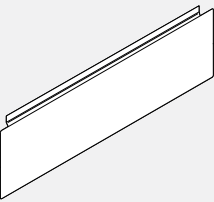

- Offers an alternative to the existing raceway options.
- Cover hinges upward for easy access to power and data/communication terminals.
- Cover may be removed for installation and reconfiguration.
- May not be used with Boulevard System 3 panels.
- Sold as singles.

PRODUCT CODE	PRICE	SIZE/ INCHES			WEIGHT VOL	
		H	W	D	LBS	FT ³
BARC06	25	00.0	5	0.125	0.3	0.001
BARC18	27	00.0	17	0.125	1.1	0.001
BARC24	32	00.0	23	0.125	1.4	0.001
BARC30	35	00.0	29	0.125	1.8	0.002
BARC36	37	00.0	35	0.125	2.2	0.002
BARC42	40	00.0	41	0.125	2.5	0.002
BARC48	42	00.0	47	0.125	2.9	0.003
BARC54	48	00.0	53	0.125	3.2	0.003
BARC60	58	00.0	59	0.125	3.7	0.003
BARC66	63	00.0	65	0.125	4.1	0.004
BARC72	67	00.0	72	0.125	4.4	0.004

Boulevard 1 • Flat Aluminum Trims

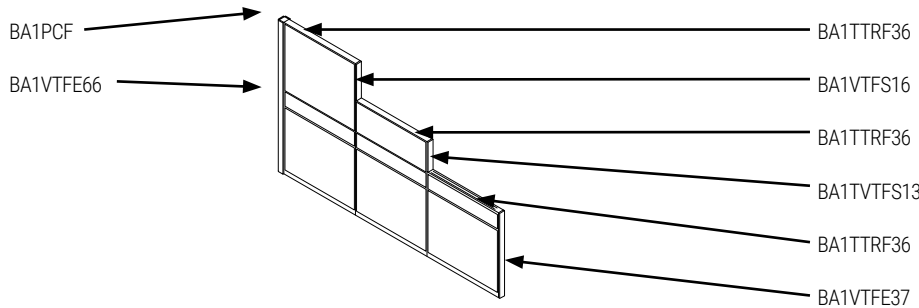

- Flat Aluminum Trims For Boulevard 1: Designed to use top and vertical trims together on the panel. Specifying vertical trims only will make them too long and will not fit correctly.
- You must specify vertical trims as a special if you are NOT using top trims.
- Post caps BA1PCF must be specified separately when using trims, .

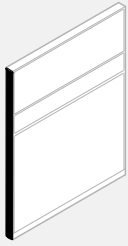
BA1VTFE • Aluminum Vertical Flat End Trim

- Provides a finish detail to the end of a panel run.
- Aluminum flat profile with injection molded top cap.
- Included: 2 "capture strip" panel connectors and 1 injection molded top cap.
- The Aluminum End Trim is designed to snap at the end of the panel or post.
- Site installed.
- For use with Aluminum Top Caps.

PRODUCT CODE	PRICE	SIZE/ INCHES			WEIGHT VOL	
		H	W	D	LBS	FT ³
BA1VTFE29	36	29	2.61	0.125	0.7	0.01
BA1VTFE37	44	37	2.61	0.125	1.0	0.02
BA1VTFE42	49	42	2.61	0.125	1.2	0.03
BA1VTFE50	56	50	2.61	0.125	1.5	0.04
BA1VTFE54	70	54	2.61	0.125	1.6	0.04
BA1VTFE58	77	58	2.61	0.125	1.7	0.04
BA1VTFE66	80	66	2.61	0.125	2.0	0.05
BA1VTFE74	85	74	2.61	0.125	2.2	0.05
BA1VTFE82	92	82	2.61	0.125	2.4	0.06

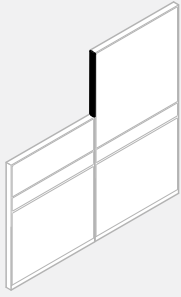
BA1VTFS • Aluminum Vertical Flat End Trim - Standard Step Down

- Provides a finish detail to the end of a panel run where 2 different height panels are specified.
- Aluminum flat profile with injection molded top cap.
- Included: 2 "capture strip" panel connectors and 1 injection molded top cap.
- The aluminum end trim is designed to snap at the end of the panel or post.
- Site installed.
- For use with Aluminum Top Caps.

PRODUCT CODE	PRICE	SIZE/ INCHES			WEIGHT VOL	
		H	W	D	LBS	FT ³
BA1VTFS04	12	4	2.61	0.125	0.1	0.01
BA1VTFS08	14	8	2.61	0.125	0.2	0.01
BA1VTFS12	21	12	2.61	0.125	0.4	0.02
BA1VTFS16	29	16	2.61	0.125	0.6	0.02
BA1VTFS20	31	20	2.61	0.125	0.6	0.03
BA1VTFS24	34	24	2.61	0.125	0.7	0.03
BA1VTFS32	38	32	2.61	0.125	0.9	0.03
BA1VTFS38	45	38	2.61	0.125	1.1	0.03
BA1VTFS40	47	40	2.61	0.125	1.1	0.03
BA1VTFS48	56	48	2.61	0.125	1.3	0.04
BA1VTFS56	65	56	2.61	0.125	1.6	0.05

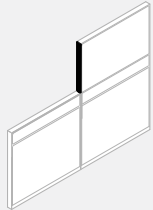
BA1VTFS • Aluminum Vertical Flat End Trim - Standard Step Down 37" High Panels

- Provides a finish detail to the end of a panel run adjacent to a 37" high panel.
- Aluminum flat profile with injection molded top cap
- Included 2 "capture strip" panel connectors and 1 injection molded top cap
- The aluminum end trim is designed to snap at the end of the panel or post
- Site installed
- Specify panels to be used when ordering a 29" step down trim.
- For use with Aluminum Top Caps.

PRODUCT CODE	PRICE	SIZE/ INCHES			WEIGHT VOL	
		H	W	D	LBS	FT ³
BA1VTFS05	13	5	2.61	0.125	0.2	0.01
BA1VTFS13	22	13	2.61	0.125	0.4	0.01
BA1VTFS17	30	17	2.61	0.125	0.4	0.01
BA1VTFS21	32	21	2.61	0.125	0.6	0.02
BA1VTFS29	35	19	2.61	0.125	0.7	0.03
BA1VTFS37	44	37	2.61	0.125	1.1	0.03
BA1VTFS45	53	45	2.61	0.125	1.3	0.04

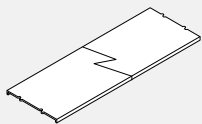
BA1TTRF • Aluminum Top Cap

- Provides a finish detail to the top of a Boulevard 1 panel.
- Designed to snap to the top of a panel rail.
- Must be used on panels of corresponding width.
- Site installed.
- For applications using transaction tops and top mounted storage, please use BHBT02FT bracket
- To be used with Flat Vertical Trim.

PRODUCT CODE	PRICE	SIZE/ INCHES			WEIGHT VOL	
		H	W	D	LBS	FT ³
BA1TTRF06	13	0.125	6	2.61	0.2	0.01
BA1TTRF18	30	0.125	18	2.61	0.6	0.02
BA1TTRF24	34	0.125	24	2.61	0.7	0.03
BA1TTRF30	36	0.125	30	2.61	0.9	0.04
BA1TTRF36	43	0.125	36	2.61	1.1	0.05
BA1TTRF42	49	0.125	42	2.61	1.3	0.06
BA1TTRF48	57	0.125	48	2.61	1.5	0.06
BA1TTRF54	70	0.125	54	2.61	1.6	0.07
BA1TTRF60	77	0.125	60	2.61	1.8	0.08
BA1TTRF66	80	0.125	66	2.61	2.0	0.09
BA1TTRF72	85	0.125	72	2.61	2.2	0.10

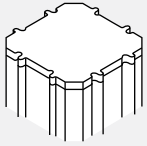
BA1PCF • Post Cap

- Bridges the height difference when using Boulevard 1 panels only with Aluminum Horizontal Top Trims.
- Injection molded post cap to fit on top of 90 degree corner post.
- Extends post's overall height to the level corresponding with the height of aluminum horizontal top trim installed on standard Boulevard panel.
- Site installed.
- Used for Boulevard 1 panels when top aluminum horizontal trim is used.

PRODUCT CODE	PRICE	SIZE/ INCHES			WEIGHT VOL	
		H	W	D	LBS	FT ³
BA1PCF	10	0.25	2.61	2.61	0.02	0.01

BHBT37FT • Transaction Bracket for 37" Panels with Flat Trim

- Provides a secure attachment of a transaction worksurface for a 37" high panel with top trim.
- Includes a left and right bracket and bracket retainer clips.

PRODUCT CODE	PRICE	SIZE/ INCHES			WEIGHT VOL	
		H	W	D	LBS	FT ³
BHBT37FT	26	3.3	1.5	2.3	2.0	0.010

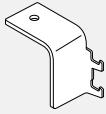
BHBT02FT • Transaction Bracket for 42" Panels with Flat Trim

- Provides a secure attachment of a transaction worksurface for a 42" high Boulevard panels with flat trim.
- Includes a left and right bracket and bracket retainer clips.

PRODUCT CODE	PRICE	SIZE/ INCHES			WEIGHT VOL	
		H	W	D	LBS	FT ³
BHBT02FT	31	4	1	3	0.5	0.007

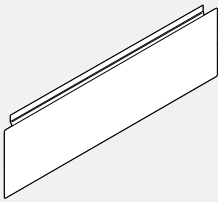
FRC • Fabric Raceway Cover

- Offers an alternative to the existing raceway options.
- Cover hinges upward for easy access to power and data/communication terminals.
- Cover may be removed for installation and reconfiguration.
- May not be used with Boulevard System 3 panels.
- Sold as singles.

PRODUCT CODE	PRICE	SIZE/ INCHES			WEIGHT VOL	
		H	W	D	LBS	FT ³
FRC24	29	7	23	0.125	1.4	0.001
FRC30	35	7	29	0.125	1.8	0.002
FRC36	37	7	35	0.125	2.2	0.002
FRC42	40	7	41	0.125	2.5	0.002
FRC48	42	7	47	0.125	2.9	0.003
FRC54	52	7	53	0.125	3.2	0.003
FRC60	55	7	59	0.125	3.7	0.003
FRC66	58	7	65	0.125	4.1	0.004
FRC72	60	7	72	0.125	4.4	0.004

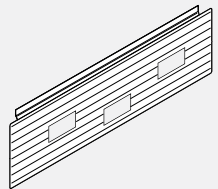
RCW-D • PVC Facemount Raceway Cover

- PVC raceway cover is punched out to align with the Face Mount Power Distribution Housing and Duplexes.
- Data punch-out accepts industry standard terminal faceplates (not supplied by Global Contract Inc.) Size of opening is 1.37" x 2.755".
- Electrical cut-outs have black PVC trim. Size of opening is 1.5" x 2.85".
- May not be used with Boulevard System 3 Panels.
- Cover hinges upward for easy access to power and data/communication terminals.

PRODUCT CODE	PRICE	SIZE/ INCHES			WEIGHT VOL	
		H	W	D	LBS	FT ³
RCW24D	36	7	24	0.125	3	0.05
RCW30D	38	7	30	0.125	3	0.06
RCW36D	43	7	36	0.125	4	0.07
RCW42D	53	7	42	0.125	5	0.08
RCW48D	57	7	48	0.125	5	0.09
RCW54D	60	7	54	0.125	6	0.10
RCW60D	64	7	60	0.125	7	0.11
RCW66D	67	7	66	0.125	7	0.12
RCW72D	72	7	72	0.125	8	0.12

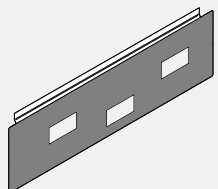
FCR-D • Fabric Covered Facemount Raceway

- Fabric raceway cover is punched out to align with the Face Mount Power Distribution Housing and Duplexes.
- Data punch-out accepts industry standard terminal faceplates (not supplied by Global Contract Inc.) Size of opening is 1.37" x 2.755".
- Electrical cut-outs have black PVC trim. Size of opening is 1.5" x 2.85".
- May not be used with Boulevard System 3 Panels.
- Cover hinges upward for easy access to power and data/communication terminals.

PRODUCT CODE	PRICE	SIZE/ INCHES			WEIGHT VOL	
		H	W	D	LBS	FT ³
FCR24D	82	7	24	0.125	3	0.05
FCR30D	89	7	30	0.125	3	0.06
FCR36D	92	7	36	0.125	4	0.07
FCR42D	97	7	42	0.125	5	0.08
FCR48D	103	7	48	0.125	5	0.09
FCR54D	106	7	54	0.125	6	0.10
FCR60D	112	7	60	0.125	7	0.11
FCR66D	116	7	66	0.125	7	0.12
FCR72D	124	7	72	0.125	8	0.12

RCA-D • Aluminum Raceway Cover for Face Mounted

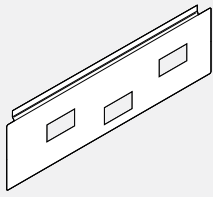

- Aluminum raceway cover is punched out to align with the Face Mount Power Distribution Housing and Duplexes.
- Data punch-out accepts industry standard terminal faceplates (not supplied by Global Contract Inc.) Size of opening is 1.37" x 2.755".
- Electrical cut-outs have black PVC trim. Size of opening is 1.5" x 2.85".
- May not be used with Boulevard System 3 Panels.
- Cover hinges upward for easy access to power and data/communication terminals.

PRODUCT CODE	PRICE	SIZE/ INCHES			WEIGHT VOL	
		H	W	D	LBS	FT ³
RCA24D	63	7	24	0.125	2.0	0.06
RCA30D	66	7	30	0.125	2.1	0.06
RCA36D	72	7	36	0.125	2.2	0.07
RCA42D	78	7	42	0.125	2.5	0.08
RCA48D	80	7	48	0.125	2.9	0.09
RCA54D	88	7	54	0.125	3.2	0.10
RCA60D	91	7	60	0.125	3.7	0.11
RCA66D	95	7	66	0.125	3.9	0.12
RCA72D	102	7	72	0.125	4.1	0.12

BPMB • Raceway Cover Caps

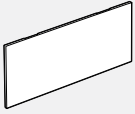

- To provide clean detail for the punch-outs of a raceway cover when the punch-outs are not in use. Order only when required.
- Made of injection molded ABS.
- B = Black
- W = White
- G = Grey

PRODUCT CODE	PRICE	SIZE/ INCHES			WEIGHT VOL	
		H	W	D	LBS	FT ³
BPMB020104B	10	1.5	3	0.125	0.04	0.02
BPMB020104G	10	1.5	3	0.125	0.04	0.02
BPMB020104W	10	1.5	3	0.125	0.04	0.02

BHSL • Safety Lock

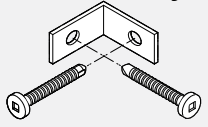

- Provides customers a higher degree of privacy.
- Safety Lock is a set of two ready made brackets and
- It is installed from the inside of a panel adjacent to a opening the door through the raceway.
- To be used for PVC raceways only.

PRODUCT CODE	PRICE
BHSL02	31

BHV • Component Wall Adapter - Single and Double

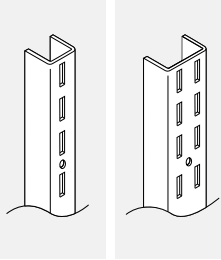

- Used to attach system components to fixed wall.
- Panel frame finish.
- The vertical wall adapter is a "U" shaped channel with a vertical row of slots with 1" centers.
- The double Component Wall Adapter has a double row of slots with 1" centers.
- Comes in 60" length only.
- Care should be taken to mount adapters only to wall studs using correct fasteners.
- Does not include mounting hardware. Mounting hardware selection to be based on wall material.
- Sold in pairs.
- Failure to do this may result in collapse of the unit and subsequent possible personal injury.

PRODUCT CODE	PRICE	SIZE/ INCHES			WEIGHT VOL	
		H	W	D	LBS	FT ³
BHV01	102	60	0.75	0.5	4	0.009
BHV02	117	60	1.50	0.5	5	0.026

BECC01 • Cable Terminal Channel

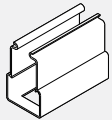

- Houses various combinations of voice and data cables.
- 1 included with every Raceway Panel.
- Accommodates assorted snap-in modular voice and data terminals (not supplied by Global Contract Inc).
- Black only.

PRODUCT CODE	PRICE	SIZE/ INCHES			WEIGHT VOL	
		H	W	D	LBS	FT ³
BECC01	31	6	4.5	2.5	.20	0.21

BPHC01 • Cable Terminal Channel

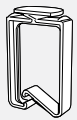

- Houses various combinations of voice and data cables.
- 2 included with every Raceway Panel.
- Black only.
- For use with Boulevard 1 Panels only.

PRODUCT CODE	PRICE	SIZE/ INCHES			WEIGHT VOL	
		H	W	D	LBS	FT ³
BPHC01	9	2.5	1	2	0.1	0.003

BOULEVARD SYSTEM 3

Boulevard System 3 Panel System

Boulevard System 3... The next generation of BOULEVARD offers the freedom to plan the office environment 'your way', while keeping an eye on the bottom line. Boulevard System 3 boasts a rich toolbox featuring stack-on panels, complete data/communication lay-in at the top, comprehensive power and data/communication at both the base and at desk height, a selection of interchangeable tiles, monolithic panels, up-mounted storage, new ergonomic worksurface shapes & a revised colour pallet featuring recycled fabrics... all wrapped up in a sophisticated design statement. Enjoy planning it your way and having the tools to really do it. Boulevard System 3 offers the building blocks to create the framework that perfectly suits your office environment. Combinations of fabric, glazed, open and slat wall panel surface tiles effectively support the creation of various work settings, whether open (to encourage interaction and teamwork) or traditional, with enclosed functional task organizers. Boulevard System 3 lets you plan more effectively and with more versatility than ever before.

It is simple to comprehend, specify, install, maintain and reconfigure. Offering multifunctional furnishing solutions, Boulevard System 3 can be specified on its own or used as a power/data and privacy provider, bridging freestanding/mobile furniture and panels and task related options such as worksurface shapes that help you work better. By utilizing up-mount storage, lower panel heights can be maintained without sacrificing overhead storage where and when needed. Another value-oriented tool... Consider 'Spine' planning to create a power wall that feeds data/communication to a string of perpendicular offices. Incorporate monolithic panels which offer the best cost/performance advantages for value sensitive environments with base panel raceway power/data cable distribution, while adding visual interest...and of course, reconfiguration is a breeze. Now you can have an endless visual pallet and array of practical solutions for today's ever changing and demanding workplace. When you add it all up, Boulevard System 3 gives you more value than ever before.

Technical Information

Panels

- All panels are 2 5/8" thick.
- Lightweight aluminum box frame construction creates superior panel rigidity.
- Panel frame finish is durable epoxy powder coated.
- Hang-on capabilities at 1" increments.
- Patented "Knuckle-Loc" design provides solid panel-to-panel connection for fast installation and reconfiguration.
- Knuckle lock feature ensures even panel heights throughout installation.
- 3" glide stem permits 2 1/2" height adjustment.
- Panel sizes are actual, eliminating creepage.
- Vertical end trims must be specified to give the panel a finished appearance.
- Horizontal top trims are included with all panels.
- All panels include 2 "Capture Strip" panel connectors.
- Panels are UL listed and CSA approved and have a Class "A" fire rating except when Customer's Own Material (COM) is used.
- All panels accept Over Panels (see page D.7).

Panel Options

- Laminate, whiteboard, or corkboard may be substituted for fabric on panels only, see "OPT" column.
- Laminate and whiteboard are held in place with a PVC retainer matching the frame colour and can be retrofitted on site.
- Laminate and whiteboard options reduce the acoustical value of the panel.

Monolithic Panels

- Fabric on Monolithic Panels can be re-upholstered on site.

Pass Thru Panels

- Fabric at base of Pass-Thru Panels can be re-upholstered on site.
- Tiles cannot be re-upholstered on site.

Bottom Lay-in Raceway

- Bottom raceway snaps to the bottom of the panel and can be completely removed for unobstructed cable lay-in installation.
- Bottom lay-in raceway is 60 mm (2.380") wide x 141 mm (5.560") high.
- Maximum capacity: 70 cables 5 mm (0.200) diameter, 2 parallel 8 wire, 4 circuit power distribution.
- State-of-the-art engineering.
- Snap-in modularity of all electrical components including harnesses, distribution housings, duplexes and circuit designations.
- All power and data outlets are easily accessible from both sides of panel.
- 8 wire system with 4, 15 amp circuits (including 1 dedicated circuit).
- Facemount electrical with 2 duplex per panel side.
- Included is 1 data/communication terminal bracket per side.

- Raceway cover openings of 2.71" x 1.38" can accommodate a single modular Data/Comm terminal plate per side (not supplied by Global Contract Inc).
- Opening complies with the ANSI/TIA/EIA standard furniture openings.
- Outlet and circuit changes accomplished without disruption to work station.
- Large raceway cavity permits storage of excess cables and equipment cords.
- Total flexibility for 8 wire system: choice of up to 4 duplexes per panel; choice of circuitry in each duplex .
- Unique design of fire retardant metal raceway cover permits access to raceway without disruption to equipment.

Horizontal Lay-in Channel (Excluding all panels with Embedded Glass)

- Integrated horizontal lay-in channel 33.5 m (1.320") wide and 38 mm (1.500") high at the top of panels and on top of the door frame.
- Maximum capacity: 36 cables 5 mm (0.200") in diameter.
- Maximum cable bending radius between two perpendicular panels: 141.2 mm (5.560") [5 mm (0.200") in diameter cables].

Vertical Wire Channel

- Where applicable, the vertical wire channel connects horizontal channel above desk height with floor level raceway.
- Opening in horizontal channel allows for vertical cable passage from top lay-in channel to base raceway.
- Integrated vertical channel 76 mm (2.990") x 27 mm (1.060").
- Maximum capacity: 60 cables 5 mm (0.200") in diameter.
- Maximum cable bending radius: 141.2 mm (5.560").

Posts

- Enables connection for multiple panel runs such as 90°, 45° or 60° angle and 2 way, 3 way or 4 way.
- Starts at the top of the bottom lay-in raceway.
- 90 degree post provides route for ceiling power and data entry to a panel raceway.
- Knuckle lock feature maintains even height of all connected panels.
- Solid lightweight aluminum extrusion fits together through a unique "Knuckle-Loc" design providing rigid post-to-panel connection.
- Post has punch-outs at the top to allow for unobstructed horizontal cable passage between adjacent panels.
- Includes all required panel connectors and caps.
- Posts add 2 5/8" to a panel run.
- Posts are 1/8" oversized to allow for "panel wrap around" of freestanding desks.
- For all panel runs with multiple posts, this 1/8" must be allotted for.
- Maximum capacity:
 - 80 cables 5mm(0.200") diameter
 - 65 cables 5mm(0.200") diameter with 1 power feed
 - 50 cables 5mm (0.200") diameter with 2 power feeds

PANELS - GUIDELINES FOR ORDERING PRODUCT**Codes**

The product guide uses a numbering system with meaningful alphanumeric characters to create a simple-to-understand product number. This makes specifying the product much easier and more accurate.

Example of Panel: **BPX3MA6636 CHR CHR P1**

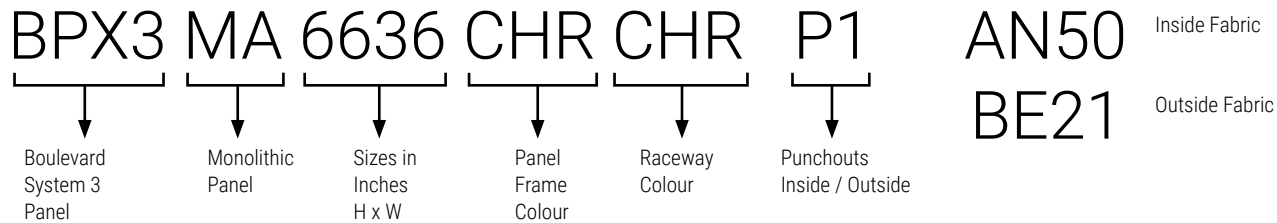
**How to Specify**

- Specify Boulevard System 3 panel type and size by code.
- Specify panel frame finish - ie. CHR (Charcoal).
- Specify PVC raceway finish - ie. CHR (Charcoal). If raceway colour not specified at time of order, default will be the panel frame colour.
- Specify all two panel fabric options if necessary.
- Some fabrics have directional pattern and cannot be applied horizontally or vertically. Panels wider than 60" will have fabrics applied horizontally (railroad). Please specify if you want adjacent panels and the rest of the installation upholstered the same way.
- Specify whether punchouts are required inside and outside of raceway or if no knockouts are required.
 - P2 - Punchouts on both sides.
 - P1 - Punchouts on one side.
 - NP - No punchouts.
- For special width panels, a special must be processed and additional costs apply. Please contact your customer service representative.

Example of Post: **BH3PS066 CHR**

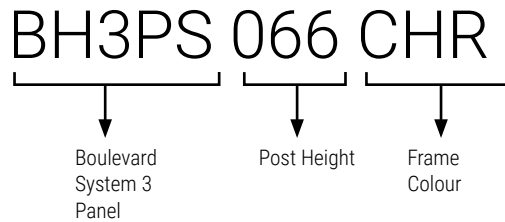
**How to Specify**

- Specify Boulevard System 3 post by code.
- Specify frame colour - ie. CHR (Charcoal).

ORDERS

Each Order Must Include

- Purchase Order
- Layout showing where the image(s) appear in the run of panels.
- A completed Price Chart, showing the location of the image(s) on each appropriate panel.

Artwork must be submitted in accordance with the following artwork specifications.

NOTE: Final artwork specification approval must be given before order can be processed.

Transfer Devices

- E-mail up to 10MB to your Global Contract Customer Service Representative.
- Courier CD/DVD/USB stick to your Global Contract Customer Service Representative.

Artwork Specifications

- Non-Photographic artwork should be vector art, saved in Adobe Illustrator (.ai), SVG or an EPS (.eps)
- All bitmap or photographic artwork has to be at a minimum of 100 dpi at the full size of the panel to be printed.
- We accept Adobe CS5 files.
- Any linked files must be included or imbedded.
- Leave any PSD files unflattened
- All fonts must be converted to outlines.
- Do not convert to CMYK, leave all images as RGB if possible
- No Word, Powerpoint, Publisher or other Microsoft files can be used.
- Include a PDF or .jpg for reference when sending native Photoshop or Illustrator format files.

Colour Matching

- A Pantone colour reference must be supplied or we cannot accept responsibility for correct colour.
- When it is not possible to refer to Pantone colours, we will do our best to meet your requirements.

Image Clarity

- We will advise should the selected image not lend itself to the element size requested.

NOTE:

We reserve the right to put an order on hold when the files are found to be incomplete or when documents have been either incorrectly saved. Fonts not converted to curves or the job appears not to be commercially acceptable.

Image Bleed:

To facilitate placement on the panel. Extension of the image past the finished visible area of the panel (bleed) is required

- Boulevard Panels need a 5" Bleed on all sides.

Example Of Image resolution:

The resolution required for a 36 wide x 24 high Boulevard panel at 100dpi (minimum resolution)

The resolution required for a 36 wide x 24 high Boulevard panel at 300dpi (higher quality)

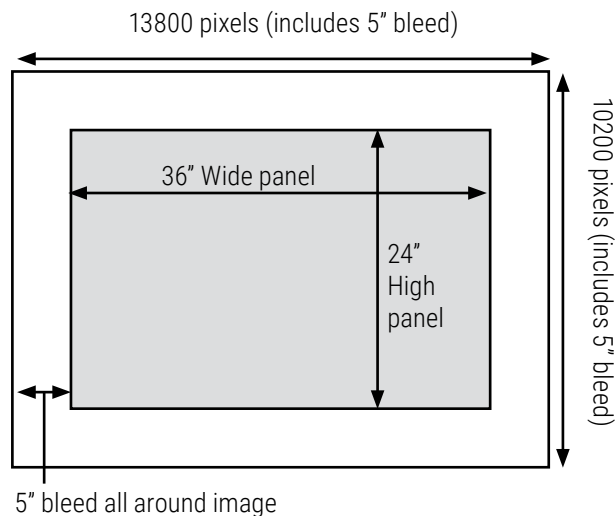
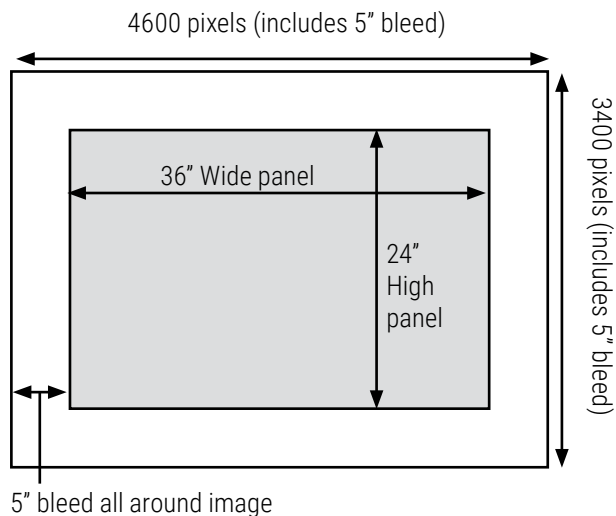

Pricing, Initial Set-Up Charge per Image:\$264 net

Boulevard System 3 Tiles



- This List applies to the following panels:
- BP3FT
- BP3ET

PANEL WIDTH	HEIGHT 8"	LIST PRICE 16"
24"	144	211
30"	173	248
36"	197	286
42"	227	324
48"	248	364
54"	279	408
60"	303	446
66"	324	476
72"	353	513

Boulevard System 3 Bottom Section of Pass-Through Panel

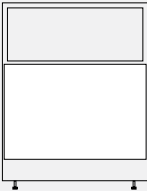

- This List applies to the following panels:
- BPX3PT
- BPX3PV

PANEL WIDTH	LIST PRICE 28"
24"	303
30"	353
36"	408
42"	469
48"	520
54"	574
60"	626
66"	680
72"	731

Boulevard System 3 Monolithic Panels

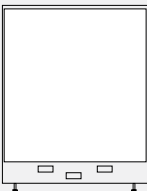

- This List applies to the following panels:
- BPX3MA
- BPX3MV

PANEL WIDTH	HEIGHT 34"	LIST PRICE 42"	50"	66"
24"	303	370	431	567
30"	353	431	513	661
36"	408	499	589	770
42"	469	567	656	874
48"	520	633	754	972
54"	574	699	823	1079
60"	626	770	905	1175
66"	680			
72"	731			

Note: Prices shown are an upcharge to the panel price, please add to the list price of panel which you are specifying the graphic for.

BPX3MA • Monolithic Acoustical Panel

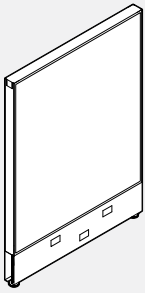

- Provides visual and acoustic privacy.
- Centre septum above raceway overlaid on either side with 1 1/8" "Sound absorbent mineral board".
- Acoustic rating of .70 NRC and 25 STC.
- OPT* = Laminate or Whiteboard
- "No Knockouts" option for raceways available at no additional charge. Please choose option for interior and/or exterior raceways.

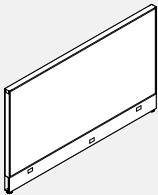

72" Wide

PRODUCT CODE	PRICE			SIZE/ INCHES			WEIGHT LBS	VOL FT ³
	GR 1	GR 2	OPT*	H	W	D		
BPX3MA3418	371	392	415	34	18	2.61	11	1.337
BPX3MA3424	411	433	455	34	24	2.61	12	1.738
BPX3MA3430	452	475	495	34	30	2.61	13	2.139
BPX3MA3436	491	537	580	34	36	2.61	15	2.540
BPX3MA3442	537	578	623	34	42	2.61	16	2.941
BPX3MA3448	577	619	661	34	48	2.61	18	3.342
BPX3MA3454	621	660	709	34	54	2.61	20	3.743
BPX3MA3460	658	699	747	34	60	2.61	22	4.144
BPX3MA3466	697	757	823	34	66	2.61	26	4.612
BPX3MA3472	737	796	-	34	72	2.61	30	5.080
BPX3MA4218	398	426	456	42	18	2.61	12	1.782
BPX3MA4224	442	472	501	42	24	2.61	13	2.317
BPX3MA4230	485	514	544	42	30	2.61	15	2.852
BPX3MA4236	527	584	645	42	36	2.61	17	3.387
BPX3MA4242	574	630	691	42	42	2.61	19	3.921
BPX3MA4248	619	676	736	42	48	2.61	21	4.456
BPX3MA4254	660	720	780	42	54	2.61	23	4.991
BPX3MA4260	701	759	820	42	60	2.61	25	5.525
BPX3MA4266	774	888	1012	42	66	2.61	29	6.148
BPX3MA4272	840	956	-	42	72	2.61	34	6.770
BPX3MA5018	512	552	600	50	18	2.61	13	2.106
BPX3MA5024	565	607	653	50	24	2.61	15	2.738
BPX3MA5030	621	660	709	50	30	2.61	17	3.370
BPX3MA5036	671	755	849	50	36	2.61	20	4.002
BPX3MA5042	724	811	901	50	42	2.61	23	4.634
BPX3MA5048	779	863	955	50	48	2.61	24	5.266
BPX3MA5054	830	916	1006	50	54	2.61	25	5.898
BPX3MA5060	885	970	1062	50	60	2.61	27	6.530
BPX3MA5066	958	1073	1198	50	66	2.61	33	7.265
BPX3MA5072	1029	1146	-	50	72	2.61	40	8.000
BPX3MA5418	535	575	621	54	18	2.61	14	2.406
BPX3MA5424	586	629	673	54	24	2.61	16	3.181
BPX3MA5430	643	686	727	54	30	2.61	19	3.907
BPX3MA5436	694	780	870	54	36	2.61	22	4.602
BPX3MA5442	751	835	928	54	42	2.61	25	5.306
BPX3MA5448	804	888	982	54	48	2.61	26	5.966
BPX3MA5454	857	942	1034	54	54	2.61	27	7.287
BPX3MA5460	913	997	1089	54	60	2.61	30	7.539
BPX3MA6618	596	668	745	66	18	2.61	14	2.755
BPX3MA6624	656	725	802	66	24	2.61	17	3.581
BPX3MA6630	711	780	854	66	30	2.61	20	4.407
BPX3MA6636	766	882	1000	66	36	2.61	24	5.234
BPX3MA6642	826	938	1061	66	42	2.61	26	6.060
BPX3MA6648	883	996	1117	66	48	2.61	28	6.887
BPX3MA6654	937	1052	1171	66	54	2.61	30	7.713
BPX3MA6660	996	1108	1231	66	60	2.61	32	8.539

BPX3MAH • Monolithic Acoustical Hallway Panel

- Provides visual and acoustic privacy.
- Centre septum above raceway overlaid on either side with 1 1/8" "Sound absorbent mineral board".
- One side is with raceway at base, other side has full fabric.
- Acoustic rating of .70 NRC and 25 STC.
- OPT* = Laminate or Whiteboard
- No Knockouts* option for raceways available at no additional charge. Please choose option for interior and/or exterior raceways.

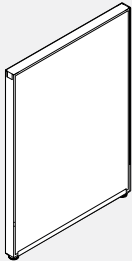
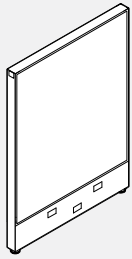

Outside

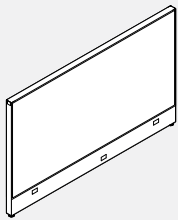

72" Wide

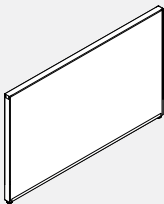

72" Wide Outside

PRODUCT CODE	PRICE			SIZE/ INCHES			WEIGHT LBS	VOL FT ³
	GR 1	GR 2	OPT*	H	W	D		
BPX3MAH3418	371	392	415	34	18	2.61	11	1.34
BPX3MAH3424	411	433	455	34	24	2.61	12	1.74
BPX3MAH3430	452	475	495	34	30	2.61	13	2.14
BPX3MAH3436	491	537	580	34	36	2.61	15	2.54
BPX3MAH3442	537	578	623	34	42	2.61	16	2.94
BPX3MAH3448	577	619	661	34	48	2.61	18	3.34
BPX3MAH3454	621	660	709	34	54	2.61	20	3.74
BPX3MAH3460	658	699	747	34	60	2.61	22	4.14
BPX3MAH3466	697	757	823	34	66	2.61	26	4.61
BPX3MAH3472	737	796	-	34	72	2.61	30	5.08
BPX3MAH4218	398	426	456	42	18	2.61	12	1.78
BPX3MAH4224	442	472	501	42	24	2.61	13	2.32
BPX3MAH4230	485	514	544	42	30	2.61	15	2.85
BPX3MAH4236	527	584	645	42	36	2.61	17	3.39
BPX3MAH4242	574	630	691	42	42	2.61	19	3.92
BPX3MAH4248	619	676	736	42	48	2.61	21	4.46
BPX3MAH4254	660	720	780	42	54	2.61	23	4.99
BPX3MAH4260	701	759	820	42	60	2.61	25	5.53
BPX3MAH4266	774	888	1012	42	66	2.61	29	6.15
BPX3MAH4272	840	956	-	42	72	2.61	34	6.77
BPX3MAH5018	512	552	600	50	18	2.61	13	2.11
BPX3MAH5024	565	607	653	50	24	2.61	15	2.74
BPX3MAH5030	621	660	709	50	30	2.61	17	3.37
BPX3MAH5036	671	755	849	50	36	2.61	20	4.00
BPX3MAH5042	724	811	901	50	42	2.61	23	4.63
BPX3MAH5048	779	863	955	50	48	2.61	24	5.27
BPX3MAH5054	830	916	1006	50	54	2.61	25	5.90
BPX3MAH5060	885	970	1062	50	60	2.61	27	6.53
BPX3MAH5066	958	1073	1198	50	66	2.61	33	7.27
BPX3MAH5072	1029	1146	-	50	72	2.61	40	8.00
BPX3MAH5418	535	575	621	54	18	2.61	14	2.41
BPX3MAH5424	586	629	673	54	24	2.61	16	3.18
BPX3MAH5430	643	686	727	54	30	2.61	19	3.91
BPX3MAH5436	694	780	870	54	36	2.61	22	4.60
BPX3MAH5442	751	835	928	54	42	2.61	25	5.31
BPX3MAH5448	804	888	982	54	48	2.61	26	5.97
BPX3MAH5454	857	942	1034	54	54	2.61	27	7.29
BPX3MAH5460	913	997	1089	54	60	2.61	30	7.54
BPX3MAH6618	596	668	745	66	18	2.61	14	2.76
BPX3MAH6624	656	725	802	66	24	2.61	17	3.58
BPX3MAH6630	711	780	854	66	30	2.61	20	4.41
BPX3MAH6636	766	882	1000	66	36	2.61	24	5.23
BPX3MAH6642	826	938	1061	66	42	2.61	26	6.06
BPX3MAH6648	883	996	1117	66	48	2.61	28	6.89
BPX3MAH6654	937	1052	1171	66	54	2.61	30	7.71
BPX3MAH6660	996	1108	1231	66	60	2.61	32	8.54

BPX3MV • Monolithic Acoustical Panel with Vertical Wire Channel

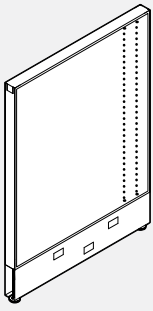

- Provides visual and acoustic privacy and allows for vertical cable passage from top lay-in channel to bottom raceway within panel.
- Centre septum above raceway overlaid on either side with 1 1/8" "Sound absorbent mineral board".
- Acoustic rating of .70 NRC and 25 STC. Includes integrated vertical wire channel.
- OPT* = Laminate or Whiteboard
- "No Knockouts" option for raceways available at no additional charge. Please choose option for interior and/or exterior raceways.

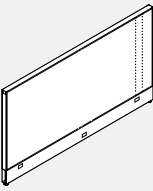

72" Wide

PRODUCT CODE	PRICE			SIZE/ INCHES			WEIGHT LBS	VOL FT ³
	GR 1	GR 2	OPT*	H	W	D		
BPX3MV3430	486	509	534	34	30	2.61	15	2.139
BPX3MV3436	527	570	614	34	36	2.61	17	2.540
BPX3MV3442	569	610	656	34	42	2.61	18	2.941
BPX3MV3448	610	654	697	34	48	2.61	20	3.342
BPX3MV3454	654	694	741	34	54	2.61	22	3.743
BPX3MV3460	692	734	780	34	60	2.61	24	4.144
BPX3MV3466	783	842	907	34	66	2.61	29	4.612
BPX3MV3472	785	845	-	34	72	2.61	34	5.080
BPX3MV4230	535	562	591	42	30	2.61	17	2.852
BPX3MV4236	574	630	691	42	36	2.61	19	3.387
BPX3MV4242	622	680	740	42	42	2.61	21	3.921
BPX3MV4248	660	720	780	42	48	2.61	23	4.456
BPX3MV4254	707	762	824	42	54	2.61	25	4.991
BPX3MV4260	749	806	867	42	60	2.61	27	5.525
BPX3MV4266	827	943	1066	42	66	2.61	32	6.148
BPX3MV4272	898	1017	-	42	72	2.61	38	6.770
BPX3MV5030	672	715	759	50	30	2.61	19	3.370
BPX3MV5036	727	814	907	50	36	2.61	22	4.002
BPX3MV5042	780	864	956	50	42	2.61	25	4.634
BPX3MV5048	835	920	1012	50	48	2.61	26	5.266
BPX3MV5054	886	971	1063	50	54	2.61	27	5.898
BPX3MV5060	942	1027	1119	50	60	2.61	29	6.530
BPX3MV5066	1026	1142	1265	50	66	2.61	35	7.265
BPX3MV5072	1108	1225	-	50	72	2.61	40	8.000
BPX3MV5430	701	746	790	54	30	2.61	19	3.907
BPX3MV5436	758	843	935	54	36	2.61	22	4.602
BPX3MV5442	812	895	987	54	42	2.61	25	5.306
BPX3MV5448	867	952	1043	54	48	2.61	26	5.966
BPX3MV5454	920	1003	1095	54	54	2.61	27	7.287
BPX3MV5460	975	1061	1153	54	60	2.61	30	7.539
BPX3MV6630	791	863	937	66	30	2.61	22	4.407
BPX3MV6636	845	958	1079	66	36	2.61	26	5.234
BPX3MV6642	905	1018	1139	66	42	2.61	28	6.060
BPX3MV6648	960	1073	1196	66	48	2.61	30	6.887
BPX3MV6654	1017	1129	1250	66	54	2.61	32	7.713
BPX3MV6660	1073	1187	1306	66	60	2.61	34	8.539

BPX3MG • Monolithic Glazed Panel

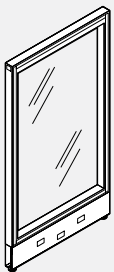

- Full-height glazing provides visual accessibility.
- Glazing is replaceable on site. Tempered clear glass standard.
- Glazing is standard on one side.
- "No Knockouts" option for raceways available at no additional charge. Please choose option for interior and/or exterior raceways.

PRODUCT CODE	PRICE		SIZE/ INCHES			WEIGHT LBS	VOL FT ³
	CLR	FRST	H	W	D		
BPX3MG5024	898	1080	50	24	2.61	25	2.738
BPX3MG5030	1142	1369	50	30	2.61	29	3.370
BPX3MG5036	1209	1450	50	36	2.61	33	4.002
BPX3MG5042	1276	1533	50	42	2.61	36	4.634
BPX3MG5048	1344	1611	50	48	2.61	41	5.266
BPX3MG5424	958	1148	54	24	2.61	29	3.138
BPX3MG5430	1160	1394	54	30	2.61	34	3.807
BPX3MG5436	1236	1483	54	36	2.61	38	4.602
BPX3MG5442	1310	1573	54	42	2.61	43	5.334
BPX3MG5448	1383	1661	54	48	2.61	48	6.066
BPX3MG6624	1121	1345	66	24	2.61	33	3.581
BPX3MG6630	1216	1460	66	30	2.61	39	4.407
BPX3MG6636	1318	1581	66	36	2.61	44	5.234
BPX3MG6642	1411	1694	66	42	2.61	49	6.060
BPX3MG6648	1506	1809	66	48	2.61	54	6.887

BPX3PT • Pass-Thru Panel - Fabric Base

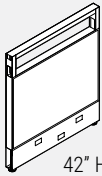

42" High

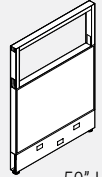

50" High

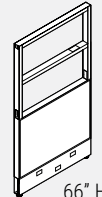

66" High

- Opening allows choice of tile above desk height.
- Solid fabric base up to 34".
- Single 8" opening above 34" for 42" high panels.
- Single 16" opening above 34" for 50" high panels.
- Two individual 16" openings above 34" for 66" high panels.
- Horizontal cable management at 34" height.
- OPT* = Laminate or Whiteboard.
- *No Knockouts* option for raceways available at no additional charge. Please choose option for interior and/or exterior raceways.

PRODUCT CODE	PRICE			SIZE/ H	INCHES			WEIGHT LBS	VOL FT ³
	GR 1	GR 2	OPT*		W	D			
BPX3PT4218	380	409	441	42	18	2.61	14	1.689	
BPX3PT4224	431	457	488	42	24	2.61	16	2.233	
BPX3PT4230	476	505	537	42	30	2.61	17	2.792	
BPX3PT4236	520	548	580	42	36	2.61	19	3.351	
BPX3PT4242	567	593	626	42	42	2.61	21	3.908	
BPX3PT4248	614	644	676	42	48	2.61	23	4.466	
BPX3PT4254	659	689	721	42	54	2.61	26	5.025	
BPX3PT4260	705	733	763	42	60	2.61	27	5.592	
BPX3PT4266	752	812	877	42	66	2.61	32	6.148	
BPX3PT4272	801	860	-	42	72	2.61	38	6.700	
BPX3PT5018	380	409	441	50	18	2.61	15	2.106	
BPX3PT5024	431	457	488	50	24	2.61	17	2.738	
BPX3PT5030	476	505	537	50	30	2.61	18	3.370	
BPX3PT5036	520	548	580	50	36	2.61	20	4.002	
BPX3PT5042	567	593	626	50	42	2.61	22	4.634	
BPX3PT5048	614	644	676	50	48	2.61	24	5.266	
BPX3PT5054	659	689	721	50	54	2.61	27	5.898	
BPX3PT5060	705	733	763	50	60	2.61	29	6.530	
BPX3PT5066	752	812	877	50	66	2.61	34	7.265	
BPX3PT5072	801	860	-	50	72	2.61	40	8.000	
BPX3PT6618	475	505	536	66	18	2.61	19	2.755	
BPX3PT6624	527	557	589	66	24	2.61	21	3.581	
BPX3PT6630	586	615	647	66	30	2.61	23	4.407	
BPX3PT6636	638	668	697	66	36	2.61	25	5.234	
BPX3PT6642	694	724	755	66	42	2.61	27	6.060	
BPX3PT6648	754	784	814	66	48	2.61	30	6.887	
BPX3PT6654	805	835	865	66	54	2.61	33	7.713	
BPX3PT6660	863	893	922	66	60	2.61	36	8.539	

BPX3PTH • Pass-Thru Hallway Panel - Fabric Base

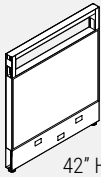

42" High

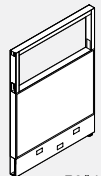
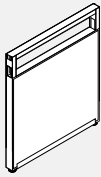

50" High

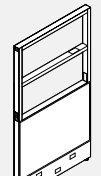
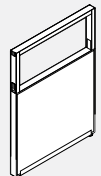

66" High

- Opening allows choice of tile above desk height.
- Solid fabric base up to 34".
- Single 8" opening above 34" for 42" high panels.
- Single 16" opening above 34" for 50" high panels.
- Two individual 16" openings above 34" for 66" high panels.
- One side is with raceway at base, other side has full fabric.
- Horizontal cable management at 34" height.
- OPT* = Laminate or Whiteboard
- *No Knockouts* option for raceways available at no additional charge. Please choose option for interior and/or exterior raceways.

PRODUCT CODE	PRICE			SIZE/ H	INCHES			WEIGHT LBS	VOL FT ³
	GR 1	GR 2	OPT*		W	D			
BPX3PTH4218	380	409	441	42	18	2.61	14	1.69	
BPX3PTH4224	431	457	488	42	24	2.61	16	2.23	
BPX3PTH4230	476	505	537	42	30	2.61	17	2.79	
BPX3PTH4236	520	548	580	42	36	2.61	19	3.35	
BPX3PTH4242	567	593	626	42	42	2.61	21	3.91	
BPX3PTH4248	614	644	676	42	48	2.61	23	4.47	
BPX3PTH4254	659	689	721	42	54	2.61	26	5.03	
BPX3PTH4260	705	733	763	42	60	2.61	27	5.59	
BPX3PTH4266	752	812	877	42	66	2.61	32	6.15	
BPX3PTH4272	801	860	-	42	72	2.61	38	6.70	
BPX3PTH5018	380	409	441	50	18	2.61	15	2.11	
BPX3PTH5024	431	457	488	50	24	2.61	17	2.74	
BPX3PTH5030	476	505	537	50	30	2.61	18	3.37	
BPX3PTH5036	520	548	580	50	36	2.61	20	4.00	
BPX3PTH5042	567	593	626	50	42	2.61	22	4.63	
BPX3PTH5048	614	644	676	50	48	2.61	24	5.27	
BPX3PTH5054	659	689	721	50	54	2.61	27	5.90	
BPX3PTH5060	705	733	763	50	60	2.61	29	6.53	
BPX3PTH5066	752	812	877	50	66	2.61	34	7.27	
BPX3PTH5072	801	860	-	50	72	2.61	40	8.00	
BPX3PTH6618	475	505	536	66	18	2.61	19	2.76	
BPX3PTH6624	527	557	589	66	24	2.61	21	3.58	
BPX3PTH6630	586	615	647	66	30	2.61	23	4.41	
BPX3PTH6636	638	668	697	66	36	2.61	25	5.23	
BPX3PTH6642	694	724	755	66	42	2.61	27	6.06	
BPX3PTH6648	754	784	814	66	48	2.61	30	6.89	
BPX3PTH6654	805	835	865	66	54	2.61	33	7.71	
BPX3PTH6660	863	893	922	66	60	2.61	36	8.54	

BPX3PV • Pass-Thru Panel with Vertical Wire Channel

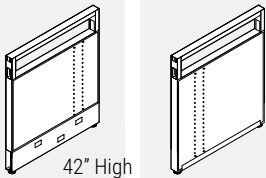

42" High

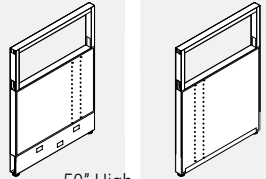

50" High

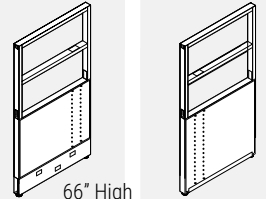

66" High

- Opening allows choice of tile above desk height. Vertical wire channel allows passage of cables from top lay-in channel to bottom raceway within panel.
- Solid fabric base up to 34".
- Single 8" opening above 34" for 42" high panels.
- Single 16" opening above 34" for 50" high panels.
- Two individual 16" openings above 34" for 66" high panels.
- Includes integrated vertical wire channel.
- Horizontal cable management at 34" height.
- OPT* = Laminate or Whiteboard.
- "No Knockouts" option for raceways available at no additional charge. Please choose option for interior and or exterior raceways.

PRODUCT CODE	PRICE			SIZE/ INCHES			WEIGHT LBS	VOL FT ³
	GR 1	GR 2	OPT*	H	W	D		
BPX3PV4230	520	548	580	42	30	2.61	19	2.792
BPX3PV4236	567	593	626	42	36	2.61	21	3.351
BPX3PV4242	614	644	676	42	42	2.61	23	3.908
BPX3PV4248	659	689	721	42	48	2.61	23	4.466
BPX3PV4254	705	733	763	42	54	2.61	28	5.025
BPX3PV4260	755	784	816	42	60	2.61	30	5.592
BPX3PV4266	792	852	917	42	66	2.61	36	6.148
BPX3PV4272	830	891	-	42	72	2.61	42	6.700
BPX3PV5030	520	548	580	50	30	2.61	20	3.370
BPX3PV5036	567	593	626	50	36	2.61	22	4.002
BPX3PV5042	614	644	676	50	42	2.61	24	4.634
BPX3PV5048	659	689	721	50	48	2.61	26	5.266
BPX3PV5054	705	733	763	50	54	2.61	29	5.898
BPX3PV5060	755	784	816	50	60	2.61	31	6.530
BPX3PV5066	792	852	917	50	66	2.61	37	7.265
BPX3PV5072	830	891	-	50	72	2.61	44	8.000
BPX3PV6630	630	659	691	66	30	2.61	25	4.407
BPX3PV6636	688	718	748	66	36	2.61	27	5.234
BPX3PV6642	741	773	801	66	42	2.61	29	6.060
BPX3PV6648	797	827	857	66	48	2.61	32	6.887
BPX3PV6654	852	883	913	66	54	2.61	35	7.713
BPX3PV6660	908	937	969	66	60	2.61	38	8.539

BPX3PF • Pass-Thru Panel - Air Flow Base

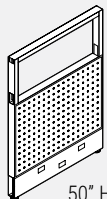

50" High

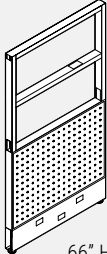

66" High

- Allows air to flow freely through the bottom of the panel.
- Double wall perforated metal base up to 34".
- Single 16" opening above 34" for 50" high panels.
- Two individual 16" openings above 34" for 66" high panels.
- Horizontal cable management at 34" height.
- "No Knockouts" option for raceways available at no additional charge. Please choose option for interior and/or exterior raceways.

PRODUCT CODE	PRICE	SIZE/ INCHES			WEIGHT LBS	VOL FT ³
		H	W	D		
BPX3PF5018	536	50	18	2.61	17	2.106
BPX3PF5024	605	50	24	2.61	18	2.738
BPX3PF5030	673	50	30	2.61	20	3.370
BPX3PF5036	749	50	36	2.61	22	4.002
BPX3PF5042	824	50	42	2.61	23	4.634
BPX3PF5048	895	50	48	2.61	26	5.266
BPX3PF5054	969	50	54	2.61	28	5.898
BPX3PF5060	1038	50	60	2.61	31	6.530
BPX3PF6618	625	66	18	2.61	21	2.755
BPX3PF6624	705	66	24	2.61	23	3.581
BPX3PF6630	791	66	30	2.61	25	4.407
BPX3PF6636	874	66	36	2.61	27	5.234
BPX3PF6642	960	66	42	2.61	29	6.060
BPX3PF6648	1045	66	48	2.61	32	6.887
BPX3PF6654	1129	66	54	2.61	35	7.713
BPX3PF6660	1212	66	60	2.61	37	8.539

BPX3OP • Over Panel Frame

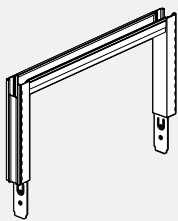

- Attaches to the top of any Boulevard System 3 panel to create a floor-to-ceiling wall.
- Any tile can be attached to either side to enclose the frame.
- Two slotted uprights at either end slide into vertical extrusions on the base panel.
- Shipped without horizontal and vertical trim; the horizontal trim from the base panel will be used.
- Openings in horizontal channels allow for vertical cable passage from top lay-in channel and behind the cover tiles
- Over Panel Frames 18" and 24" wide are not punched for vertical wire channel.
- Boulevard System 3 Over Panel is not compatible with Boulevard 1 panels.
- Hang-on capabilities not to exceed 66" high or in conjunction with glass tiles.

PRODUCT CODE	PRICE	SIZE/ INCHES			WEIGHT LBS	VOL FT ³
		H	W	D		
BPX3OP0818	93	8	18	2.61	3	0.383
BPX3OP0824	102	8	24	2.61	4	0.438
BPX3OP0830	109	8	30	2.61	4	0.656
BPX3OP0836	117	8	36	2.61	4	0.712
BPX3OP0842	131	8	42	2.61	5	0.875
BPX3OP0848	138	8	48	2.61	5	0.930
BPX3OP0854	146	8	54	2.61	6	1.040
BPX3OP0860	156	8	60	2.61	6	1.204
BPX3OP0866	173	8	66	2.61	7	1.310
BPX3OP0872	192	8	72	2.61	8	1.420
BPX3OP1618	93	16	18	2.61	4	0.638
BPX3OP1624	102	16	24	2.61	5	0.730
BPX3OP1630	109	16	30	2.61	5	1.094
BPX3OP1636	117	16	36	2.61	5	1.186
BPX3OP1642	131	16	42	2.61	6	1.459
BPX3OP1648	138	16	48	2.61	6	1.550
BPX3OP1654	146	16	54	2.61	7	1.733
BPX3OP1660	156	16	60	2.61	7	2.006
BPX3OP1666	173	16	66	2.61	9	2.165
BPX3OP1672	192	16	72	2.61	10	2.370

BP3PBEG • Embedded Glass and Top Trim Kit

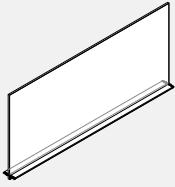

- **Embedded Glass and Top Trim Kit attaches on top of panels to add privacy or divide space.**
- Embedded Glass Top Trim Kit consist of the extruded aluminum channel, die-cast channel end covers, glass partition, gasket and hardware required to secure the trim to the panel's horizontal channel.
- Specify standard metal paint finish.
- Clear tempered glass is standard.
- NOTE: When specifying an application where two panels are side by side at different heights, a special is required to ensure proper fit.

PRODUCT CODE	PRICE		SIZE/INCHES			WEIGHT LBS	VOL FT ³
	CLR	FRST	H	W	D		
BP3PBEG0824	129	213	8	24	2.61	9.42	0.29
BP3PBEG0830	137	220	8	30	2.61	11.79	0.36
BP3PBEG0836	144	229	8	36	2.61	14.15	0.44
BP3PBEG0842	152	237	8	42	2.61	16.52	0.51
BP3PBEG0848	168	262	8	48	2.61	18.88	0.58
BP3PBEG0854	186	291	8	54	2.61	19.52	0.65
BP3PBEG0860	204	320	8	60	2.61	20.58	0.73
BP3PBEG0866	221	350	8	66	2.61	21.55	0.80
BP3PBEG0872	245	385	8	72	2.61	23.62	0.87
BP3PBEG1624	134	218	16	24	2.61	9.89	0.58
BP3PBEG1630	165	264	16	30	2.61	12.38	0.73
BP3PBEG1636	184	311	16	36	2.61	14.86	0.87
BP3PBEG1642	210	357	16	42	2.61	17.35	1.02
BP3PBEG1648	236	404	16	48	2.61	19.82	1.16
BP3PBEG1654	261	425	16	54	2.61	21.25	1.31
BP3PBEG1660	286	496	16	60	2.61	23.62	1.45
BP3PBEG1666	312	543	16	66	2.61	25.98	1.60
BP3PBEG1672	343	595	16	72	2.61	28.35	1.74

BP3PBEF • Embedded PET Felt and Top Trim Kit

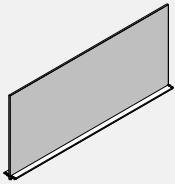

- **Embedded PET Felt and Top Trim Kit attaches on top of panels to add privacy or divide space.**
- Embedded PET Felt Top Trim Kit consist of the extruded aluminum channel, die-cast channel end covers, PET felt partition and hardware required to secure the trim to the panels horizontal channel.
- Specify standard metal paint finish.
- 9mm PET felt material is tackable and comes in 18 different colours. Please specify colour.
- NOTE: When specifying an application where two panels are side by side at different heights, a special is required to ensure proper fit.

PRODUCT CODE	PRICE		SIZE/INCHES			WEIGHT LBS	VOL FT ³
	H	W	D	LBS	FT ³		
BP3PBEF0824	63		8	24	2.61	1.32	0.29
BP3PBEF0830	66		8	30	2.61	1.65	0.36
BP3PBEF0836	88		8	36	2.61	1.99	0.44
BP3PBEF0842	92		8	42	2.61	2.32	0.51
BP3PBEF0848	165		8	48	2.61	2.65	0.58
BP3PBEF0854	169		8	54	2.61	2.98	0.65
BP3PBEF0860	172		8	60	2.61	3.32	0.73
BP3PBEF0866	176		8	66	2.61	3.65	0.80
BP3PBEF0872	185		8	72	2.61	3.98	0.87
BP3PBEF1624	63		16	24	2.61	1.83	0.58
BP3PBEF1630	66		16	30	2.61	2.30	0.73
BP3PBEF1636	88		16	36	2.61	2.76	0.87
BP3PBEF1642	92		16	42	2.61	3.22	1.02
BP3PBEF1648	165		16	48	2.61	3.68	1.16
BP3PBEF1654	169		16	54	2.61	4.14	1.31
BP3PBEF1660	172		16	60	2.61	4.61	1.45
BP3PBEF1666	176		16	66	2.61	5.07	1.60
BP3PBEF1672	185		16	72	2.61	5.53	1.74

BP3PBEFP • Embedded Perforated PET Felt and Top Trim Kit

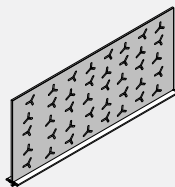

- **Embedded PET Felt and Top Trim Kit attaches on top of panels to add privacy or divide space.**
- Embedded PET Felt Top Trim Kit consist of the extruded aluminum channel, die-cast channel end covers, PET felt partition and hardware required to secure the trim to the panels horizontal channel.
- Specify standard metal paint finish.
- 9mm PET felt material is tackable and comes in 18 different colours. Please specify colour.
- NOTE: When specifying an application where two panels are side by side at different heights, a special is required to ensure proper fit.

PRODUCT CODE	PRICE		SIZE/INCHES			WEIGHT LBS	VOL FT ³
	H	W	D	LBS	FT ³		
BP3PBEFP0824	126		8	24	2.61	1.32	0.29
BP3PBEFP0830	133		8	30	2.61	1.65	0.36
BP3PBEFP0836	175		8	36	2.61	1.99	0.44
BP3PBEFP0842	182		8	42	2.61	2.32	0.51
BP3PBEFP0848	330		8	48	2.61	2.65	0.58
BP3PBEFP0854	337		8	54	2.61	2.98	0.65
BP3PBEFP0860	345		8	60	2.61	3.32	0.73
BP3PBEFP0866	352		8	66	2.61	3.65	0.80
BP3PBEFP0872	371		8	72	2.61	3.98	0.87
BP3PBEFP1624	126		16	24	2.61	1.83	0.58
BP3PBEFP1630	133		16	30	2.61	2.30	0.73
BP3PBEFP1636	175		16	36	2.61	2.76	0.87
BP3PBEFP1642	182		16	42	2.61	3.22	1.02
BP3PBEFP1648	330		16	48	2.61	3.68	1.16
BP3PBEFP1654	337		16	54	2.61	4.14	1.31
BP3PBEFP1660	345		16	60	2.61	4.61	1.45
BP3PBEFP1666	352		16	66	2.61	5.07	1.60
BP3PBEFP1672	371		16	72	2.61	5.53	1.74

BP3DS • Solid Door Panel

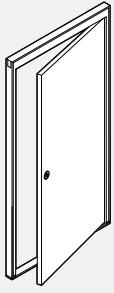

- **Aluminum frame with either high pressure laminate door.**
- 1 3/8" thick hollow core door.
- Actual door size:
79.9" x 32 1/2" in 82" x 36" frame
79.9" x 38 1/2" in 82" x 42" frame
- 42" wide Door Panel permits wheelchair accessibility.
- No hang-on capabilities.
- 180 degree swing.
- Specify Door Knob (DL01) or Door Lever (DL02).
- Lock standard.
- Handedness can be changed on site.
- Please specify Right hand (R) or Left hand (L) hung.
- Includes a Horizontal Lay-in Channel.

PRODUCT CODE	PRICE HP	SIZE/ H	INCHES			WEIGHT VOL	
			W	D	LBS	FT ³	
BP3DS8236R	2331	82	36	2.61	61	6.465	
BP3DS8242R	2539	82	42	2.61	68	7.486	
BP3DS8236L	2331	82	36	2.61	61	6.465	
BP3DS8242L	2539	82	42	2.61	68	7.486	

Door Hanging Directions

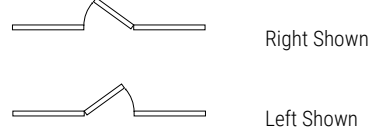

Door Handle Option

- Door Knob - DL01
- Lock Standard
- Door Lever - DL02 (Default)
- Lock Standard
- Lever complies with all accessibility standards



BP3DH • Half Glazed Door Panel

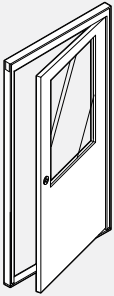

- **Aluminum frame with either high pressure laminate door and window.**
- 1 3/8" thick hollow core door.
- Actual door size:
79.9" x 32 1/2" in 82" x 36" frame
79.9" x 38 1/2" in 82" x 42" frame
- 42" wide Door Panel permits wheelchair accessibility.
- No hang-on capabilities.
- 180 degree swing.
- Specify Door Knob (DL01) or Door Lever (DL02).
- Lock standard.
- Handedness can be changed on site.
- Please specify Right hand (R) or Left hand (L) hung.
- For tempered glass option, add "TG" at the end of the product code and add an upcharge of \$149 for 36" wide doors and \$189 for 42" wide doors.
- Includes a Horizontal Lay-in Channel.

PRODUCT CODE	PRICE HP	SIZE/ H	INCHES			WEIGHT VOL	
			W	D	LBS	FT ³	
BP3DH8236R	2891	82	36	2.61	53	6.465	
BP3DH8242R	3160	82	42	2.61	59	7.486	
BP3DH8236L	2891	82	36	2.61	53	6.465	
BP3DH8242L	3160	82	42	2.61	59	7.486	

Door Hanging Directions

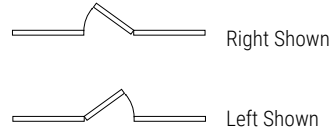

Door Handle Option

- Door Knob - DL01
- Lock Standard
- Door Lever - DL02 (Default)
- Lock Standard
- Lever complies with all accessibility standards



BP3DG • Full Glazed Door Panel

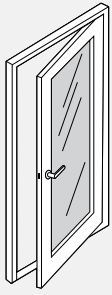

- Aluminum frame with either high pressure laminate door and window.
- 1 3/8" thick hollow core door.
- Actual door size:
79.9" x 32 1/2" in 82" x 36" frame
79.9" x 38 1/2" in 82" x 42" frame
- 42" wide Door Panel permits wheelchair accessibility.
- No hang-on capabilities.
- 180 degree swing.
- Specify Door Knob (DL01) or Door Lever (DL02).
- Lock standard.
- Handedness can be changed on site.
- Please specify Right hand (R) or Left hand (L) hung.
- For tempered glass option, add "TG" at the end of the product code and add an upcharge of \$302 for 36" wide doors and \$376 for 42" wide doors.
- Includes a Horizontal Lay-in Channel.
- Laminate frame is 5" thick at the sides and 4" at the top and bottom.

PRODUCT CODE	PRICE		SIZE/ INCHES			WEIGHT VOL	
	HP		H	W	D	LBS	FT ³
BP3DG8236R	3324		82	36	2.61	53	6.465
BP3DG8242R	3637		82	42	2.61	59	7.486
BP3DG8236L	3324		82	36	2.61	53	6.465
BP3DG8242L	3637		82	42	2.61	59	7.486

Door Hanging Directions



Right Shown

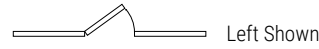

Left Shown

Door Handle Option

Door Knob - DL01

- Lock Standard

Door Lever - DL02 (Default)

- Lock Standard

- Lever complies with all accessibility standards



BPX3NET • Removable Face Tile - Electrical Tile Kit

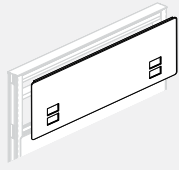
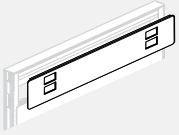

- Attaches to an 8" or 16" opening in a Pass-Thru Panel.
- Fabric covered tile with knock-out for power and data. (Data/Comm blank covers not included).
- 24" wide tiles have one duplex and one data/comm opening. 30" and wider tiles have two duplex and two data/comm openings.
- Easily interchangeable on site.
- Provides access to electrical and data at a required location.
- Specify Tile Electrical Kit separately.
- Duplexes and covers must be specified separately.
- For power outlets on both sides of the panel, specify two Electrical Tiles per panel. For power outlets on one side only, specify one Electrical Tile and a Fabric Tile for the opposite side.
- OPT* = Laminate or Whiteboard.
- For use on panels manufactured after November 1, 2014

PRODUCT CODE	PRICE			SIZE/ INCHES			WEIGHT VOL	
	GR 1	GR 2	OPT*	H	W	D	LBS	FT ³
BPX3NET0824	197	210	225	8	24	0.125	2.0	0.170
BPX3NET0830	221	236	249	8	30	0.125	2.5	0.200
BPX3NET0836	247	262	276	8	36	0.125	2.5	0.250
BPX3NET0842	259	270	284	8	42	0.125	2.5	0.292
BPX3NET0848	263	276	291	8	48	0.125	3.0	0.333
BPX3NET0854	274	286	303	8	54	0.125	3.0	0.375
BPX3NET0860	280	295	309	8	60	0.125	4.5	0.417
BPX3NET0866	312	371	435	8	66	0.125	4.7	0.475
BPX3NET0872	343	405	-	8	72	0.125	5.0	0.500
BPX3NET1624	197	210	225	16	24	0.125	2.5	3.400
BPX3NET1630	221	236	249	16	30	0.125	3.0	0.416
BPX3NET1636	247	262	276	16	36	0.125	3.0	0.500
BPX3NET1642	259	270	284	16	42	0.125	3.0	0.583
BPX3NET1648	263	276	291	16	48	0.125	4.0	0.666
BPX3NET1654	274	286	303	16	54	0.125	4.0	0.750
BPX3NET1660	280	295	309	16	60	0.125	5.0	0.833
BPX3NET1666	312	371	435	16	66	0.125	5.5	0.911
BPX3NET1672	343	405	-	16	72	0.125	6.0	1.000

BP3GT • Removable Face Tile - Glazed

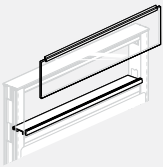

- Attaches to any opening in a Pass-Thru Panel.
- 8" or 16" high glazing provides visual accessibility and light transfer.
- Easily interchangeable on site.
- Specify one Glazed Tile for panel opening of corresponding width.
- Clear tempered glass standard.

PRODUCT CODE	PRICE			SIZE/ INCHES			WEIGHT VOL	
	CLR	FRST		H	W	D	LBS	FT ³
BP3GT0818	103	124		8	18	2.61	2.3	0.146
BP3GT0824	115	138		8	24	2.61	3.1	0.165
BP3GT0830	127	151		8	30	2.61	3.9	0.200
BP3GT0836	148	178		8	36	2.61	4.7	0.250
BP3GT0842	173	208		8	42	2.61	5.5	0.292
BP3GT0848	200	238		8	48	2.61	6.3	0.333
BP3GT0854	225	270		8	54	2.61	7.1	0.375
BP3GT0860	249	301		8	60	2.61	7.8	0.417
BP3GT0866	276	331		8	66	2.61	8.6	0.460
BP3GT0872	301	363		8	72	2.61	9.4	0.500
BP3GT1618	109	131		16	18	2.61	4.3	0.292
BP3GT1624	125	149		16	24	2.61	5.8	0.333
BP3GT1630	144	172		16	30	2.61	7.2	0.416
BP3GT1636	174	210		16	36	2.61	8.7	0.500
BP3GT1642	204	245		16	42	2.61	10.2	0.583
BP3GT1648	235	280		16	48	2.61	11.6	0.666
BP3GT1654	264	317		16	54	2.61	13.1	0.750
BP3GT1660	295	352		16	60	2.61	14.6	0.833
BP3GT1666	324	372		16	66	2.61	16.0	0.911
BP3GT1672	352	406		16	72	2.61	17.5	1.000

BP3DGT • Removable Face Tile - Double Glazed

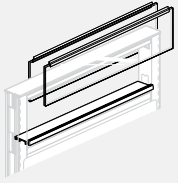

- Attaches to any opening in a Pass-Thru Panel.
- 8" or 16" high glazing provides visual accessibility and light transfer.
- Easily interchangeable on site.
- Specify one Double Glazed Tile for panel opening of corresponding width.
- Clear tempered glass standard.

PRODUCT CODE	PRICE CLR	FRST	SIZE/ INCHES			WEIGHT LBS	VOL FT ³
			H	W	D		
BP3DGT0818	191	227	8	18	2.61	6.0	0.292
BP3DGT0824	210	249	8	24	2.61	8.2	0.330
BP3DGT0830	234	276	8	30	2.61	10.4	0.400
BP3DGT0836	284	340	8	36	2.61	12.6	0.500
BP3DGT0842	331	397	8	42	2.61	14.7	0.584
BP3DGT0848	378	456	8	48	2.61	16.9	0.666
BP3DGT0854	430	514	8	54	2.61	19.0	0.750
BP3DGT0860	477	573	8	60	2.61	21.3	0.834
BP3DGT0866	524	629	8	66	2.61	23.4	0.920
BP3DGT0872	573	687	8	72	2.61	25.6	1.000
BP3DGT1618	202	240	16	18	2.61	10.0	0.584
BP3DGT1624	215	260	16	24	2.61	13.6	0.666
BP3DGT1630	274	328	16	30	2.61	17.1	0.832
BP3DGT1636	333	399	16	36	2.61	20.6	1.000
BP3DGT1642	388	465	16	42	2.61	24.1	1.166
BP3DGT1648	446	536	16	48	2.61	27.7	1.322
BP3DGT1654	503	604	16	54	2.61	31.2	1.500
BP3DGT1660	561	672	16	60	2.61	34.7	1.666
BP3DGT1666	618	711	16	66	2.61	38.2	1.822
BP3DGT1672	672	774	16	72	2.61	41.7	2.000

BP30T • Removable Face Tile - Open Pass-Thru Kit

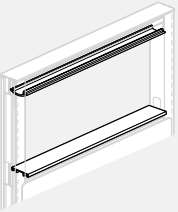

- Attaches to any opening in a Pass-Thru Panel.
- Trims and internal corners included to create an opening.
- Easily interchangeable on site.
- Specify one Pass-Thru Kit for panel opening of corresponding width.
- Kit works for 8" & 16" openings.
- Please specify panel frame colour.

PRODUCT CODE	PRICE	SIZE/ INCHES			WEIGHT LBS	VOL FT ³
		H	W	D		
BP30T1618	19	16	18	2.61	0.4	0.292
BP30T1624	22	16	24	2.61	0.6	0.333
BP30T1630	27	16	30	2.61	0.8	0.416
BP30T1636	31	16	36	2.61	1.0	0.500
BP30T1642	35	16	42	2.61	1.1	0.583
BP30T1648	41	16	48	2.61	1.3	0.666
BP30T1654	45	16	54	2.61	1.5	0.750
BP30T1660	48	16	60	2.61	1.7	0.833
BP30T1666	54	16	66	2.61	1.9	0.911
BP30T1672	56	16	72	2.61	2.0	1.000

BP3AT • Removable Face Tile - Accessory

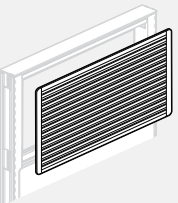

- Attaches to any opening in a Pass-Thru Panel.
- Provides support for accessories.
- Easily interchangeable on site.
- Two tile clips included.
- Specify two tiles per panel opening of corresponding width. Tiles can be combined. For example, Fabric Tile on one side and Accessory Tile on the opposite side of the same panel.
- Accessory Tile cannot be installed opposite an electrical tile.

PRODUCT CODE	PRICE	SIZE/ INCHES			WEIGHT LBS	VOL FT ³
		H	W	D		
BP3AT0818	97	08	18	0.25	1.7	0.146
BP3AT0824	115	08	24	0.25	2.3	0.167
BP3AT0830	127	08	30	0.25	2.9	0.208
BP3AT0836	149	08	36	0.25	3.5	0.250
BP3AT0842	180	08	42	0.25	4.1	0.292
BP3AT0848	211	08	48	0.25	4.7	0.333
BP3AT0854	227	08	54	0.25	5.3	0.375
BP3AT0860	259	08	60	0.25	5.9	0.417
BP3AT0866	279	08	66	0.25	6.5	0.459
BP3AT0872	303	08	72	0.25	7.0	0.500
BP3AT1618	114	16	18	0.25	3.5	0.292
BP3AT1624	138	16	24	0.25	4.7	0.333
BP3AT1630	147	16	30	0.25	5.7	0.416
BP3AT1636	178	16	36	0.25	7.0	0.500
BP3AT1642	211	16	42	0.25	8.2	0.583
BP3AT1648	245	16	48	0.25	9.4	0.666
BP3AT1654	265	16	54	0.25	10.6	0.750
BP3AT1660	304	16	60	0.25	11.9	0.833
BP3AT1666	336	16	66	0.25	13.0	0.916
BP3AT1672	366	16	72	0.25	14.0	1.000

BP3FT • Removable Face Tile - Fabric

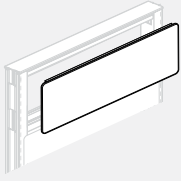

- Attaches to any opening in a Pass-Thru Panel.
- Tile clips included.
- Easily interchangeable on site.
- Specify two tiles per panel opening of corresponding width. Tiles can be combined. For example, Fabric Tile on one side and Accessory Tile on the opposite side of the same panel.
- OPT* = Laminate or Whiteboard.

PRODUCT CODE	PRICE			SIZE/ INCHES			WEIGHT VOL	
	GR1	GR2	OPT*	H	W	D	LBS	FT ³
BP3FT0818	92	100	108	8	18	0.25	1	0.146
BP3FT0824	97	106	113	8	24	0.25	1	0.165
BP3FT0830	106	117	134	8	30	0.25	2	0.200
BP3FT0836	131	144	159	8	36	0.25	2	0.250
BP3FT0842	139	151	169	8	42	0.25	2	0.292
BP3FT0848	145	159	173	8	48	0.25	3	0.333
BP3FT0854	153	169	181	8	54	0.25	3	0.375
BP3FT0860	159	172	187	8	60	0.25	4	0.417
BP3FT0866	180	239	305	8	66	0.25	4	0.460
BP3FT0872	233	307	-	8	72	0.25	4	0.500
BP3FT1618	103	110	116	16	18	0.25	2	0.292
BP3FT1624	109	115	124	16	24	0.25	2	0.333
BP3FT1630	116	132	146	16	30	0.25	3	0.416
BP3FT1636	144	157	172	16	36	0.25	3	0.500
BP3FT1642	153	169	181	16	42	0.25	3	0.583
BP3FT1648	161	174	192	16	48	0.25	4	0.666
BP3FT1654	170	181	199	16	54	0.25	4	0.750
BP3FT1660	187	247	205	16	60	0.25	5	0.833
BP3FT1666	205	264	329	16	66	0.25	5	0.920
BP3FT1672	253	336	-	16	72	0.25	6	1.000

BP3OPFA • Fabric Over Panel

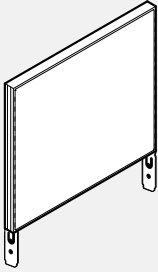

- Attaches to top of a panel to create floor-to-ceiling wall.
- Centre septum overlaid on either side with 1 1/8" "Sound absorbent mineral board".
- Exact height should be specified when ordering, with allowance of at least 1" of free space between over panel and ceiling to accommodate height variations in ceiling and floor. Can be any height from 4.4" minimum to 15.9" maximum. Please tag exact height required.
- Runs of over panels should be captured at either end with full height posts, wall adapters, taller panels, and/or vertical trims.
- OPT* = Laminate or Whiteboard.

PRODUCT CODE	PRICE			SIZE/ INCHES			WEIGHT VOL	
	GR1	GR2	OPT*	H	W	D	LBS	FT ³
BP3OPFA18	241	259	271	16	18	2.61	8	0.730
BP3OPFA24	274	286	303	16	24	2.61	8	0.730
BP3OPFA30	313	328	342	16	30	2.61	10	0.912
BP3OPFA36	353	369	383	16	36	2.61	12	1.094
BP3OPFA42	385	399	415	16	42	2.61	12	1.094
BP3OPFA48	425	439	454	16	48	2.61	14	1.277
BP3OPFA54	465	480	494	16	54	2.61	14	1.277
BP3OPFA60	495	510	523	16	60	2.61	15	1.368

BP3OPFV • Fabric Over Panel with Vertical Wire Channel

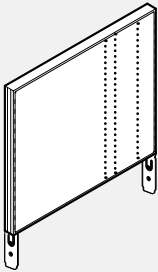

- Attaches to top of a panel to create floor-to-ceiling wall.
- Centre septum overlaid on either side with 1" sound absorbent mineral board.
- Exact height should be specified when ordering, with allowance of at least 1" of free space between over panel and ceiling to accommodate height variations in ceiling and floor. Can be any height from 4.4" minimum to 15.9" maximum. Please tag exact height required.
- Runs of over panels should be captured at either end with full height posts, wall adapters, taller panels, and/or vertical trims.
- OPT* = Laminate or Whiteboard.

PRODUCT CODE	PRICE			SIZE/ INCHES			WEIGHT VOL	
	GR1	GR2	OPT*	H	W	D	LBS	FT ³
BP3OPFV18	286	301	314	16	18	2.61	8	0.73
BP3OPFV24	317	331	344	16	24	2.61	8	0.73
BP3OPFV30	355	371	385	16	30	2.61	10	0.912
BP3OPFV36	398	411	426	16	36	2.61	12	1.094
BP3OPFV42	431	443	457	16	42	2.61	12	1.094
BP3OPFV48	471	483	499	16	48	2.61	14	1.277
BP3OPFV54	510	522	540	16	54	2.61	14	1.277
BP3OPFV60	540	551	568	16	60	2.61	15	1.368

BA3PAS • Glass Over Panel with Round Pucks for System 3

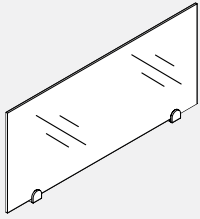

- **Glass Over Panel creates division.**
- Glass Over Panel with no frame sits on top of a System 3 Panel with clamps that are secured to the top of the panel.
- Tempered glass is 16" high.
- Custom sizes available, contact your Customer Service Representative.
- For application where the over panel is sandwiched between two taller panels, please request a special as the glass will not fit due to trims.

PRODUCT CODE	PRICE CLR	FRST	SIZE/ INCHES			WEIGHT VOL	
			H	W	D	LBS	FT ³
BA3PAS0824	204	235	8	24	1.3	4	0.22
BA3PAS0830	229	262	8	30	1.3	5	0.30
BA3PAS0836	241	283	8	36	1.3	6	0.37
BA3PAS0842	262	306	8	42	1.3	7	0.43
BA3PAS0848	281	323	8	48	1.3	8	0.48
BA3PAS1624	218	248	16	24	1.3	8	0.44
BA3PAS1630	241	276	16	30	1.3	10	0.59
BA3PAS1636	260	299	16	36	1.3	12	0.73
BA3PAS1642	276	320	16	42	1.3	14	0.85
BA3PAS1648	281	339	16	48	1.3	16	0.96

BA3PASS • Glass Over Panel with Square Pucks for System 3

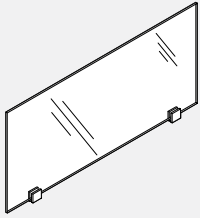

- **Glass Over Panel creates division.**
- Glass Over Panel with no frame sits on top of a System 3 Panel with clamps that are secured to the top of the panel.
- Tempered glass is 16" high.
- Custom sizes available, contact your Customer Service Representative.
- For application where the over panel is sandwiched between two taller panels, please request a special as the glass will not fit due to trims.

PRODUCT CODE	PRICE CLR	FRST	SIZE/ INCHES			WEIGHT VOL	
			H	W	D	LBS	FT ³
BA3PASS0824	218	248	8	24	1.3	4	0.22
BA3PASS0830	241	276	8	30	1.3	5	0.30
BA3PASS0836	262	299	8	36	1.3	6	0.37
BA3PASS0842	276	320	8	42	1.3	7	0.43
BA3PASS0848	298	339	8	48	1.3	8	0.48
BA3PASS1624	235	264	16	24	1.3	8	0.44
BA3PASS1630	260	291	16	30	1.3	10	0.59
BA3PASS1636	274	313	16	36	1.3	12	0.73
BA3PASS1642	291	338	16	42	1.3	14	0.85
BA3PASS1648	299	352	16	48	1.3	16	0.96

BPMB • Raceway Cover Caps



- **To provide clean detail for the punch-outs of a raceway cover when the punch-outs are not in use. Order only when required.**
- Made of injection molded ABS.
- B = Black
- G = Grey
- W = White

PRODUCT CODE	PRICE	SIZE/ INCHES			WEIGHT VOL	
		H	W	D	LBS	FT ³
BPMB020104B	10	1.5	3	0.125	0.04	0.02
BPMB020104G	10	1.5	3	0.125	0.04	0.02
BPMB020104W	10	1.5	3	0.125	0.04	0.02

BH3PS • 90 Degree Post



- **Enables connection for multiple panel runs such as 90°, 3 way and 4 way.**
- Includes 2 "Capture Strip" panel connectors, 4 end strips, 2 pairs of raceway end caps, and 1 post cap.
- Posts are designed to accept the following:
 - 75 cables 5.6mm (0.220") diameter
 - 60 ccables 5.6mm (0.220") diameter with 1 power feed
 - 45 cables 5.6mm (0.220") diameter with 2 power feeds

PRODUCT CODE	PRICE	SIZE/ INCHES			WEIGHT VOL	
		H	W	D	LBS	FT ³
BH3PS034	126	27	2.61	2.61	4	0.14
BH3PS042	138	35	2.61	2.61	5	0.18
BH3PS050	156	43	2.61	2.61	7	0.22
BH3PS054	174	47	2.61	2.61	7	0.27
BH3PS058	179	51	2.61	2.61	8	0.29
BH3PS066	187	59	2.61	2.61	8	0.31

BH3PS45 • 45 Degree Post



- **Enables connection for two panels at 45°.**
- Includes 2 "Capture Strip" panel connectors and 1 post cap.
- 45 degree post does not accept End Trim.
- No power infeed capabilities.
- Posts are designed to accept the following:
 - 30 cables 5.6mm (0.220") diameter

PRODUCT CODE	PRICE	SIZE/ INCHES			WEIGHT VOL	
		H	W	D	LBS	FT ³
BH3PS45034	126	27	2.61	2.61	4	0.14
BH3PS45042	138	35	2.61	2.61	5	0.18
BH3PS45050	156	43	2.61	2.61	7	0.22
BH3PS45054	174	47	2.61	2.61	7	0.27
BH3PS45058	179	51	2.61	2.61	8	0.29
BH3PS45066	187	59	2.61	2.61	8	0.31

BH3PS60 • 60 Degree Post



- **Enables connection for multiple panel runs such as 120° and 3 way.**
- Includes 2 "Capture Strip" panel connectors and 1 post cap.
- No power infeed capabilities.
- Posts are designed to accept the following:
 - 35 cables 5.6mm (0.220") diameter

PRODUCT CODE	PRICE	SIZE/ INCHES			WEIGHT VOL	
		H	W	D	LBS	FT ³
BH3PS60034	126	27	2.61	2.61	4	0.14
BH3PS60042	138	35	2.61	2.61	5	0.18
BH3PS60050	156	43	2.61	2.61	7	0.22
BH3PS60054	174	47	2.61	2.61	7	0.27
BH3PS60058	179	51	2.61	2.61	8	0.29
BH3PS60066	187	59	2.61	2.61	8	0.31

BH3PE • Post Extension for Over Panels

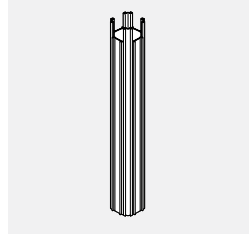

- Provides route for ceiling data or electrical cables through the post to the panel.
- Includes 2 "Capture Strip" panel connectors.

PRODUCT CODE	PRICE	SIZE/ INCHES			WEIGHT VOL	
		H	W	D	LBS	FT ³
BH3PE008	30	8	2.61	2.61	1	0.03
BH3PE016	54	16	2.61	2.61	2	0.07
BH3PE032	78	32	2.61	2.61	4	0.14
BH3PE45016	54	16	2.61	2.61	2	0.07
BH3PE45032	78	32	2.61	2.61	4	0.14
BH3PE60016	54	16	2.61	2.61	2	0.07
BH3PE60032	78	32	2.61	2.61	4	0.14

BH3PA • Off-Module Connector (Panel to Panel Adapter)

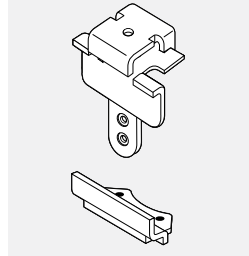

- Connects Boulevard System 3 panel to another perpendicular Boulevard System 3 Monolithic Panel off-module.
- Top and bottom brackets bolt to panel vertical of one panel and engage to top and bottom "fabric" edges of adjacent, perpendicular Monolithic Panel of even height.
- While connecting tile panel to Monolithic Panel is possible, never attempt to secure Off-Module Connectors to a tile panel.
- Once an off-module panel is secure to Monolithic Panel spine with Off-Module Connecting Kit, the raceway on the spine panel cannot be accessed and can only be opened from the opposite side.
- Special top trim required, provide application to your Customer Service Representative.
- This connector is not a load-bearing connection.
- Not to be used on the panel seam, with over panels or laminate and metal faced panels.

PRODUCT CODE	PRICE	SIZE/ H	INCHES		WEIGHT VOL	
			W	D	LBS	FT ³
BH3PA02	93	3.5			0.5	0.035

RCX3WMP2 • Raceway Cover with Punchouts Both Sides

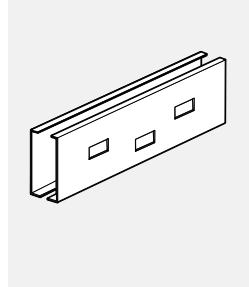

- Metal raceway organizes cables at the base.
- Snaps directly into the base of the panel.
- When opened, cover's side rests on the floor, providing unobstructed access to data/power installation.
- 18" Raceway Covers do not have power and data/communication punch-outs.
- 24" Raceway covers have electrical and one data opening.
- Data opening sizing is as follows: 1.38" x 2.71".
- Comes standard with all System 3 panels.
- "No Knockouts" option for raceways available at no additional charge. Please choose option for interior and/or exterior raceways.

PRODUCT CODE	PRICE	SIZE/ INCHES			WEIGHT VOL	
		H	W	D	LBS	FT ³
RCX3WM24P2	63	5.62	24	2.61	3.3	0.21
RCX3WM30P2	68	5.62	30	2.61	4.1	0.26
RCX3WM36P2	78	5.62	36	2.61	4.9	0.31
RCX3WM42P2	90	5.62	42	2.61	5.7	0.36
RCX3WM48P2	95	5.62	48	2.61	6.6	0.42
RCX3WM54P2	104	5.62	54	2.61	7.4	0.47
RCX3WM60P2	113	5.62	60	2.61	8.3	0.52
RCX3WM66P2	117	5.62	66	2.61	9.1	0.57
RCX3WM72P2	127	5.62	72	2.61	9.8	0.62

RCX3WMP1 • Raceway Cover with Punchouts One Side, None Other Side

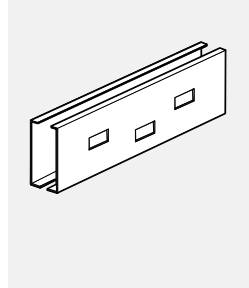

- Metal raceway organizes cables at the base.
- Snaps directly into the base of the panel.
- When opened, cover's side rests on the floor, providing unobstructed access to data/power installation.
- 18" Raceway Covers do not have power and data/communication punch-outs.
- 24" Raceway covers have electrical and one data opening.
- Data opening sizing is as follows: 1.38" x 2.71".
- Comes standard with all System 3 panels.
- "No Knockouts" option for raceways available at no additional charge. Please choose option for interior and/or exterior raceways.

PRODUCT CODE	PRICE	SIZE/ INCHES			WEIGHT VOL	
		H	W	D	LBS	FT ³
RCX3WM24P1	63	5.62	24	2.61	3.3	0.21
RCX3WM30P1	68	5.62	30	2.61	4.1	0.26
RCX3WM36P1	78	5.62	36	2.61	4.9	0.31
RCX3WM42P1	90	5.62	42	2.61	5.7	0.36
RCX3WM48P1	95	5.62	48	2.61	6.6	0.42
RCX3WM54P1	104	5.62	54	2.61	7.4	0.47
RCX3WM60P1	113	5.62	60	2.61	8.3	0.52
RCX3WM66P1	117	5.62	66	2.61	9.1	0.57
RCX3WM72P1	127	5.62	72	2.61	9.8	0.62

RCX3WMNP • Raceway Cover with No Punchouts Both Sides

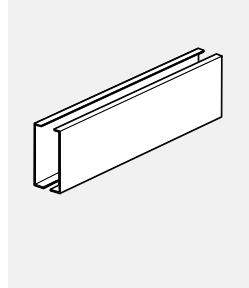

- Metal raceway organizes cables at the base.
- Snaps directly into the base of the panel.
- When opened, cover's side rests on the floor, providing unobstructed access to data/power installation.
- Specified separately for reconfiguration purposes.

PRODUCT CODE	PRICE	SIZE/ INCHES			WEIGHT VOL	
		H	W	D	LBS	FT ³
RCX3WM18NP	56	5.62	18	2.61	2.4	0.16
RCX3WM24NP	63	5.62	24	2.61	3.3	0.21
RCX3WM30NP	68	5.62	30	2.61	4.1	0.26
RCX3WM36NP	78	5.62	36	2.61	4.9	0.31
RCX3WM42NP	90	5.62	42	2.61	5.7	0.36
RCX3WM48NP	95	5.62	48	2.61	6.6	0.42
RCX3WM54NP	104	5.62	54	2.61	7.4	0.47
RCX3WM60NP	113	5.62	60	2.61	8.3	0.52
RCX3WM66NP	117	5.62	66	2.61	9.1	0.57
RCX3WM72NP	127	5.62	72	2.61	9.8	0.62

B3HWA • Wall Adapter

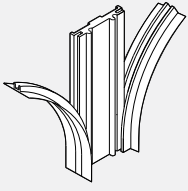

- Starts a run of panels off an existing wall.
- Includes 2 "Capture Strip" panel connectors and 1 pair of raceway end caps.
- Mounting hardware not included.
- Mounting hardware selection should be based on wall or wall stud material.
- Wall Adapter adds 5/16" to a panels run.

PRODUCT CODE	PRICE	SIZE/ INCHES			WEIGHT VOL	
		H	W	D	LBS	FT ³
B3HWA034	61	34	2.61	0.375	2	0.011
B3HWA042	64	42	2.61	0.375	3	0.015
B3HWA050	68	50	2.61	0.375	3	0.018
B3HWA054	74	54	2.61	0.375	3	0.020
B3HWA058	78	58	2.61	0.375	4	0.021
B3HWA066	80	66	2.61	0.375	4	0.021

BHWASL • Adapter Sleeve



- Wall Adapter Sleeve is attached to the building to provide flexible support to a panel run.

- As opposed to the BHW wall adapter, which connects to the panels rigidly to a wall, B1 and B3 Boulevard panels rest inside of the vertical "U" channel, providing up to 3.5" of flexible adjustment.
- For panel runs taller than 66" order two Wall Adapter Sleeves and either have it cut short on the site below ceiling, or cut a rectangular hole in the ceiling tile. Rectangular slots in the Channels correspond to 66", 58", 54", 50" and 42" high B1 and B3 panels.
- Powder coated steel; specify metal finish.
- Note: the Wall Adapter Sleeve provides flexible, non-structural connection, blocks vertical 1" increment clots and cannot, therefore, be used to support over-heads and worksurfaces, they must be supported by perpendicular panels, c-legs or gables.
- Note: no fasteners are provided with the Wall Adapter Sleeve. Select the appropriate fasteners according to a structurally sound connection.
- Cannot be used to support a door or panel and cannot be used with laminate, airflow or metal skin panels.

PRODUCT CODE	PRICE	SIZE/ INCHES			WEIGHT VOL	
		H	W	D	LBS	FT ³
BHWASL42	149	34.7	4	2	2.5	0.161
BHWASL50	162	42.7	4	2	3.6	0.148
BHWASL54	170	46.7	4	2	4.2	0.216
BHWASL58	174	52.7	4	2	5.1	0.244
BHWASL66	187	58.7	4	2	6.0	0.272

BH3CS • Capture Strip Slot Cover

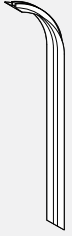

- An extruded PVC channel to adjoin two panels or a panel to a post. Runs the full length of the panel on both sides providing a positive connection of the "Knuckle-Loc" design.
- Priced per pair.
- Pliable side membranes cover panel slots.
- Included with panel components.
- Only to be ordered separately if required.

PRODUCT CODE	PRICE	SIZE/ INCHES			WEIGHT VOL	
		H	W	D	LBS	FT ³
BH3CS34	12	37			0.24	0.11
BH3CS42	12	42			0.28	0.13
BH3CS50	13	50			0.33	0.15
BH3CS54	13	54			0.31	0.17
BH3CS66	21	66			0.4	0.19

BH3CE • End Strip Slot Cover



- End strips with pliable side membrane covers panel slots at end of run.
- Priced per pair.
- Included with panel components.
- Only to be ordered separately if required.

PRODUCT CODE	PRICE	SIZE/ INCHES			WEIGHT VOL	
		H	W	D	LBS	FT ³
BH3CE34	12	37			0.12	0.05
BH3CE42	12	42			0.14	0.06
BH3CE50	13	50			0.16	0.07
BH3CE54	13	54			0.31	0.08
BH3CE66	14	66			0.20	0.09

BA3VTR • Vertical Aluminum End Trim



- Finishes the vertical edges of panels and posts (90 and 60 degree).
- In the case of the panel, the trim runs from the top of the panel to the bottom of the raceway, enclosing the horizontal channel openings and the raceway opening.
- In the case of the Over Panel, the trim runs from the top of the Over Panel to the bottom of the Over Panel, enclosing the horizontal channel openings.

PRODUCT CODE	PRICE	TYPE	SIZE/ INCHES			WEIGHT VOL	
			H	W	D	LBS	FT ³
BA3VTR34	38	REGULAR PANEL	34	2.61	0.25	1.1	0.03
BA3VTR42	46		42	2.61	0.25	1.4	0.03
BA3VTR50	56		50	2.61	0.25	1.7	0.04
BA3VTR54	64		54	2.61	0.25	1.9	0.04
BA3VTR58	67		58	2.61	0.25	2.1	0.05
BA3VTR66	75		66	2.61	0.25	2.2	0.05
BA3VTE16	24	OVER PANEL	16	2.61	0.25	0.5	0.03
BA3VTE32	38		32	2.61	0.25	1.1	0.06

BA3VTS • Vertical Aluminum End Trim Standard Step Down

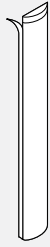

- Finishes the vertical edges of panels and posts (90 and 60 degree).
- Trims run from the top of one panel to the top of lower panel enclosing the horizontal channel opening.

PRODUCT CODE	PRICE	SIZE/ INCHES			WEIGHT VOL	
		H	W	D	LBS	FT ³
BA3VTS04	12	4	2.61	0.25	0.2	0.010
BA3VTS08	14	8	2.61	0.25	0.3	0.015
BA3VTS12	21	12	2.61	0.25	0.4	0.022
BA3VTS16	24	16	2.61	0.25	0.5	0.030
BA3VTS20	29	20	2.61	0.25	0.7	0.039
BA3VTS24	31	24	2.61	0.25	0.9	0.045
BA3VTS32	38	32	2.61	0.25	1.1	0.060

BV3VTR • Vertical PVC End Trim



- Finishes the vertical edges of panels and posts (90 and 60 degree).
- In the case of the panel, the trim runs from the top of the panel to the bottom of the raceway, enclosing the horizontal channel openings and the raceway opening.
- In the case of the over panel, the trim runs from the top of the over panel to the bottom of the over panel, enclosing the horizontal channel openings.

PRODUCT CODE	PRICE	TYPE	SIZE/ INCHES			WEIGHT VOL	
			H	W	D	LBS	FT ³
BV3VTR34	29	REGULAR PANEL	34	2.61	0.25	0.6	0.030
BV3VTR42	30		42	2.61	0.25	0.7	0.030
BV3VTR50	35		50	2.61	0.25	0.9	0.040
BV3VTR54	37		54	2.61	0.25	1.0	0.045
BV3VTR58	40		58	2.61	0.25	1.0	0.047
BV3VTR66	43		66	2.61	0.25	1.1	0.050
BV3VTE16	22	OVER PANEL	16	2.61	0.25	0.3	0.030
BV3VTE32	29		32	2.61	0.25	0.6	0.060

BV3VTS • Vertical PVC End Trim Standard Step Down



- Finishes the vertical edges of panels and posts (90 and 60 degree).
- Trims run from the top of one panel to the top of lower panel enclosing the horizontal channel opening.

PRODUCT CODE	PRICE	SIZE/ INCHES			WEIGHT VOL	
		H	W	D	LBS	FT ³
BV3VTS04	12	3.75	2.61	0.25	0.1	0.010
BV3VTS08	14	7.75	2.61	0.25	0.1	0.015
BV3VTS12	21	11.75	2.61	0.25	0.2	0.020
BV3VTS16	23	15.75	2.61	0.25	0.3	0.030
BV3VTS20	30	19.75	2.61	0.25	0.3	0.035
BV3VTS24	25	23.75	2.61	0.25	0.4	0.045
BV3VTS32	29	31.75	2.61	0.25	0.6	0.060

BA3VTRF • Vertical Aluminum Flat End Trim



- Finishes the vertical edges of panels and posts (90 and 60 degree).
- In the case of the panel, the trim runs from the top of the panel to the bottom of the raceway, enclosing the horizontal channel openings and the raceway opening.
- In the case of the over panel, the trim runs from the top of the over panel to the bottom of the over panel, enclosing the horizontal channel openings.
- BABVTRF119 cannot ship via courier and must be combined with other product.

PRODUCT CODE	PRICE	TYPE	SIZE/ INCHES			WEIGHT VOL	
			H	W	D	LBS	FT ³
BA3VTRF34	38	REGULAR PANEL	34	2.61	0.125	1.1	0.03
BA3VTRF42	46		42	2.61	0.125	1.4	0.03
BA3VTRF50	56		50	2.61	0.125	1.7	0.04
BA3VTRF54	64		54	2.61	0.125	1.9	0.04
BA3VTRF58	67		58	2.61	0.125	1.9	0.04
BA3VTRF66	69		66	2.61	0.125	2.2	0.05
BA3VTRF119	134		119	2.61	0.125	3.6	0.08
BA3VTEF8	11	OVER PANEL	8	2.61	0.125	0.2	0.01
BA3VTEF16	24		16	2.61	0.125	0.5	0.03
BA3VTEF32	38		32	2.61	0.125	1.1	0.06

BA3VTSF • Vertical Aluminum Flat End Trim Standard Step Down

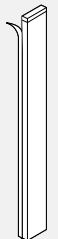

- Finishes the vertical edges of panels and posts (90 and 60 degree).
- Trims run from the top of one panel to the top of lower panel enclosing the horizontal channel opening.

PRODUCT CODE	PRICE	SIZE/ INCHES			WEIGHT VOL	
		H	W	D	LBS	FT ³
BA3VTSF04	12	3.75	2.61	0.125	0.1	0.010
BA3VTSF08	14	7.75	2.61	0.125	0.3	0.015
BA3VTSF12	21	11.75	2.61	0.125	0.4	0.020
BA3VTSF16	24	15.75	2.61	0.125	0.5	0.030
BA3VTSF20	29	19.75	2.61	0.125	0.8	0.035
BA3VTSF24	31	23.75	2.61	0.125	0.9	0.045
BA3VTSF32	38	31.75	2.61	0.125	1.1	0.060

B3LEP-NC • End of Run Gallery Panel in a T configuration, No Connectors for Additional Gallery Panels

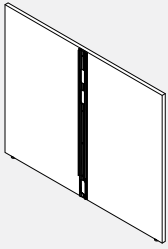

- Provides floor standing support while enclosing the end of a panel run on two sides.
- Attaches to the end of a Boulevard 1 or System 3 Panel with capture strips to form a T configuration.
- Connection is on the interior face center.
- Includes all attachment hardware and glides.
- Total height is inclusive of panel glides extended to their full height.
- 51" wide gallery panel accommodates two 24" deep surfaces while the 63" wide accommodates two 30" deep surfaces and 75" wide two 36" deep surfaces.
- Please specify LP laminate finish and PVC edge finish.
- If a wood grain laminate is chosen, grain direction run horizontally.
- Edged in PVC on three exposed edges and self edged on bottom.

PRODUCT CODE	PRICE LP	SIZE /INCHES			WEIGHT LBS	VOL FT³
		H	W	D		
B3LEP4227NC	416	42	26.5	1	29.49	0.64
B3LEP4251NC	653	42	51	1	55.17	1.24
B3LEP4263NC	731	42	63	1	68.01	1.53
B3LEP4275NC	814	42	75	1	80.86	1.82
B3LEP5027NC	485	50	26.5	1	35.25	0.77
B3LEP5051NC	758	50	51	1	65.92	1.48
B3LEP5063NC	854	50	63	1	81.27	1.82
B3LEP5075NC	964	50	75	1	96.62	2.17
B3LEP5427NC	485	54	26.5	1	38.12	0.83
B3LEP5451NC	781	54	51	1	71.3	1.59
B3LEP5463NC	880	54	63	1	87.9	1.97
B3LEP5475NC	994	54	75	1	104.49	2.34

B3LSEPL-NC • Left End of Run Single Gallery Panel in L Configuration, No Connectors for Additional Gallery Panels



- Provides floor standing support while enclosing the end of a panel run on one side.
- Attaches to the end of a Boulevard 1 or System 3 Panel with capture strips to form an L configuration.
- Connection is on interior face near it's right end.
- Includes all attachment hardware and glides.
- Total height is inclusive of panel glides extended to their full height.
- 27" wide gallery panel accommodates a 24" deep surface while the 33" wide accommodates a 30" deep surface and 39" wide a 36" deep surface.
- Please specify LP laminate finish and PVC edge finish.
- If a wood grain laminate is chosen, grain direction run horizontally.
- Edged in PVC on three exposed edges and self edged on bottom.

PRODUCT CODE	PRICE LP	SIZE /INCHES			WEIGHT LBS	VOL FT³
		H	W	D		
B3LSEPL4215NC	342	42	14.25	1	16.64	0.35
B3LSEPL4227NC	497	42	27	1	29.47	0.66
B3LSEPL4233NC	537	42	33	1	35.89	0.80
B3LSEPL4239NC	564	42	39	1	42.32	0.95
B3LSEPL5015NC	389	50	14.25	1	19.9	0.41
B3LSEPL5027NC	565	50	27	1	35.23	0.78
B3LSEPL5033NC	613	50	33	1	42.9	0.95
B3LSEPL5039NC	656	50	39	1	50.57	1.13
B3LSEPL5415NC	389	54	14.25	1	21.52	0.45
B3LSEPL5427NC	582	54	27	1	38.1	0.84
B3LSEPL5433NC	632	54	33	1	46.4	1.03
B3LSEPL5439NC	677	54	39	1	54.7	1.22

B3LSEPR-NC • Right End of Run Single Gallery Panel in L Configuration, No Connectors for Additional Gallery Panels



- Provides floor standing support while enclosing the end of a panel run on one side.
- Attaches to the end of a Boulevard 1 or System 3 Panel with capture strips to form an L configuration.
- Connection is on interior face near it's right end.
- Includes all attachment hardware and glides.
- Total height is inclusive of panel glides extended to their full height.
- 27" wide gallery panel accommodates a 24" deep surface while the 33" wide accommodates a 30" deep surface and 39" wide a 36" deep surface.
- Please specify LP laminate finish and PVC edge finish.
- If a wood grain laminate is chosen, grain direction run horizontally.
- Edged in PVC on three exposed edges and self edged on bottom.

PRODUCT CODE	PRICE LP	SIZE /INCHES			WEIGHT LBS	VOL FT³
		H	W	D		
B3LSEPR4215NC	342	42	14.25	1	16.64	0.35
B3LSEPR4227NC	497	42	27	1	29.47	0.66
B3LSEPR4233NC	537	42	33	1	35.89	0.80
B3LSEPR4239NC	564	42	39	1	42.32	0.95
B3LSEPR5015NC	389	50	14.25	1	19.9	0.41
B3LSEPR5027NC	565	50	27	1	35.23	0.78
B3LSEPR5033NC	613	50	33	1	42.9	0.95
B3LSEPR5039NC	656	50	39	1	50.57	1.13
B3LSEPR5415NC	389	54	14.25	1	21.52	0.45
B3LSEPR5427NC	582	54	27	1	38.1	0.84
B3LSEPR5433NC	632	54	33	1	46.4	1.03
B3LSEPR5439NC	677	54	39	1	54.7	1.22

B3LMP-NC • Middle of Run Single Gallery Panel in X Configuration, No Connectors for Additional Gallery Panels

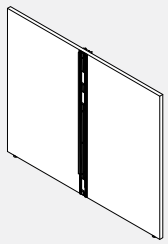

- Provides floor standing support in the middle of a panel run.
- Attaches between panels in a straight Boulevard 1 or System 3 Panel run with capture strips to form an X configuration.
- Connections are at the center of the interior and exterior faces.
- Includes all attachment hardware and glides.
- Total height is inclusive of panel glides extended to their full height.
- 51" wide gallery panel accommodates two 24" deep surfaces while the 63" wide accommodates two 30" deep surfaces and 75" wide two 36" deep surfaces.
- Please specify LP laminate finish and PVC edge finish.
- If a wood grain laminate is chosen, grain direction run horizontally.
- Edged in PVC on three exposed edges and self edged on bottom.

PRODUCT CODE	PRICE LP	SIZE /INCHES			WEIGHT LBS	VOL FT³
		H	W	D		
B3LMP4251NC	865	42	51	1	55.98	1.24
B3LMP4263NC	942	42	63	1	68.83	1.53
B3LMP4275NC	1028	42	75	1	81.68	1.85
B3LMP5051NC	981	50	51	1	66.97	1.48
B3LMP5063NC	1077	50	63	1	82.32	1.82
B3LMP5075NC	1188	50	75	1	97.67	2.17
B3LMP5451NC	1009	54	51	1	72.46	1.59
B3LMP5463NC	1109	54	63	1	89.06	1.97
B3LMP5475NC	1223	54	75	1	105.66	2.34

B3LSMP-NC • Middle of Run Single Gallery Panel in T Configuration, No Connectors for Additional Gallery Panels



- Provides floor standing support at the middle of a panel run.
- Attaches in the middle of a straight Boulevard 1 or System 3 panel run with capture strips to form a T configuration.
- Connections are on the interior and exterior faces of one end.
- Includes all attachment hardware and glides.
- Total height is inclusive of panel glides extended to their full height.
- 27" wide gallery panel accommodates a 24" deep surface while the 33" wide accommodates a 30" deep surface and 39" wide a 36" deep surface.
- Please specify LP laminate finish and PVC edge finish.
- If a wood grain laminate is chosen, grain direction run horizontally.
- Edged in PVC on three exposed edges and self edged on bottom.

PRODUCT CODE	PRICE LP	SIZE /INCHES			WEIGHT LBS	VOL FT³
		H	W	D		
B3LSMP4227NC	712	42	27	1	30.28	0.66
B3LSMP4233NC	749	42	33	1	36.71	0.80
B3LSMP4239NC	778	42	39	1	43.13	0.95
B3LSMP5027NC	788	50	27	1	36.28	0.78
B3LSMP5033NC	835	50	33	1	43.95	0.95
B3LSMP5039NC	879	50	39	1	51.63	1.13
B3LSMP5427NC	812	54	27	1	39.26	0.84
B3LSMP5433NC	861	54	33	1	47.56	1.03
B3LSMP5439NC	905	54	39	1	55.86	1.22

B3LEP • End of Run Gallery Panel in a T configuration, with Connectors for Additional Gallery Panels

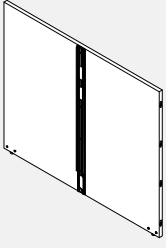

- Provides floor standing support while enclosing the end of a panel run.
- Attaches to the end of a Boulevard 1 or System 3 panel with capture strips to form a T configuration.
- Connections at both ends as well as on the middle of interior face.
- The end connections are to connect other Gallery Panels.
- The side right is compatible with right hand Gallery Panels (B3LXPRxxxx and B3LX-PRxxxxNC, B3L2PRxxxx and B3L3PRxxxx) only.
- The left side is compatible with left hand Gallery Panels (B3LXPLxxxx and B3LX-PLxxxxNC, B3L2PLxxxx and B3L3PLxxxx) only.
- The middle interior face connections are for Boulevard panels.
- Includes all attachment hardware and glides.
- Total height is inclusive of panel glides extended to their full height.
- 51" wide gallery panel accommodates two 24" deep surface while the 63" wide accommodates two 30" deep surfaces and 75" wide two 36" deep surfaces.
- Please specify LP laminate finish and PVC edge finish.
- If a wood grain laminate is chosen, grain direction run horizontally.
- Gallery panel is edged in PVC on exposed top edge only and self edged on the three other edges.

PRODUCT CODE	PRICE LP	SIZE /INCHES			WEIGHT LBS	VOL FT³
		H	W	D		
B3LEP4251	667	42	51	1	55.25	1.24
B3LEP4263	745	42	63	1	68.1	1.53
B3LEP4275	828	42	75	1	80.95	1.82
B3LEP5051	773	50	51	1	66.01	1.48
B3LEP5063	868	50	63	1	81.36	1.82
B3LEP5075	979	50	75	1	96.71	2.17
B3LEP5451	795	54	51	1	71.38	1.59
B3LEP5463	894	54	63	1	87.98	1.97
B3LEP5475	1008	54	75	1	104.58	2.34

B3LSEPL • Left End of Run Single Gallery Panel in L Configuration, with Connectors for Additional Gallery Panels



- Provides floor standing support while enclosing the end of a panel run.
- Attaches at the end of a Boulevard 1 or System 3 panel with capture strips to form an L configuration.
- Connection to the Boulevard panel is on interior face near it's right end.
- Connections for a Gallery Panel are on the left edge.
- Compatible with left hand Gallery Panels (B3LXPLxxxx and B3LXPLxxxxNC, B3L2PLxxxx and B3L3PLxxxx) only.
- Includes all attachment hardware and glides.
- Total height is inclusive of panel glides extended to their full height.
- 27" wide gallery panel accommodates a 24" deep surface while the 33" wide accommodates a 30" deep surface and 39" wide a 36" deep surface.
- Please specify LP laminate finish and PVC edge finish.
- If a wood grain laminate is chosen, grain direction run horizontally.
- Edged in PVC on two exposed edges, self edged on connecting to gallery panel edge and the bottom.

PRODUCT CODE	PRICE LP	SIZE /INCHES			WEIGHT LBS	VOL FT³
		H	W	D		
B3LSEPL4227	505	42	27	1	29.51	0.66
B3LSEPL4233	544	42	33	1	35.94	0.80
B3LSEPL4239	571	42	39	1	42.36	0.95
B3LSEPL5027	573	50	27	1	35.27	0.78
B3LSEPL5033	621	50	33	1	42.94	0.95
B3LSEPL5039	664	50	39	1	50.62	1.13
B3LSEPL5427	589	54	27	1	38.14	0.84
B3LSEPL5433	639	54	33	1	46.44	1.03
B3LSEPL5439	683	54	39	1	54.74	1.22

B3LSEPR • Right End of Run Single Gallery Panel in L Configuration, with Connectors for additional Gallery Panels



- Provides floor standing support while enclosing the end of a panel run.
- Attaches at the end of a Boulevard 1 or System 3 panel with capture strips to form an L configuration.
- Connection to the Boulevard panel is on interior face near it's left end.
- Connections for a Gallery Panel are on the right edge.
- Compatible with right hand Gallery Panels (B3LXPRxxxx and B3LXPRxxxxNC, B3L2PRxxxx and B3L3PRxxxx) only.
- Includes all attachment hardware and glides.
- Total height is inclusive of panel glides extended to their full height.
- 27" wide gallery panel accommodates a 24" deep surface while the 33" wide accommodates a 30" deep surface and 39" wide a 36" deep surface.
- Please specify LP laminate finish and PVC edge finish.
- If a wood grain laminate is chosen, grain direction run horizontally.
- Edged in PVC on two exposed edges, self edged on connecting to gallery panel edge and the bottom.

PRODUCT CODE	PRICE LP	SIZE /INCHES			WEIGHT LBS	VOL FT³
		H	W	D		
B3LSEPR4227	505	42	27	1	29.51	0.66
B3LSEPR4233	544	42	33	1	35.94	0.80
B3LSEPR4239	571	42	39	1	42.36	0.95
B3LSEPR5027	573	50	27	1	35.27	0.78
B3LSEPR5033	621	50	33	1	42.94	0.95
B3LSEPR5039	664	50	39	1	50.62	1.13
B3LSEPR5427	589	54	27	1	38.14	0.84
B3LSEPR5433	639	54	33	1	46.44	1.03
B3LSEPR5439	683	54	39	1	54.74	1.22

B3LMP • Middle of Run Single Gallery Panel in X Configuration, with Connectors for Additional Gallery Panels

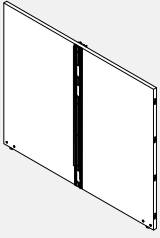

- Provides floor standing support in the middle of a panel run.
- Attached in the middle of a straight Boulevard 1 or System 3 panel run with capture strips to form an X configuration.
- Connections at both ends (for Gallery Panels) as well as on the middle of the interior and exterior faces (for Boulevard Panels).
- The right side is compatible with right hand Gallery Panels (B3LXPRxxxx and B3LX-PRxxxxNC, B3L2PRxxxx and B3L3PRxxxx) only.
- The left side is compatible with left hand Gallery Panels (B3LXPLxxxx and B3LX-PLxxxxNC, B3L2PLxxxx and B3L3PLxxxx) only.
- Includes all attachment hardware and glides.
- Total height is inclusive of panel glides extended to their full height.
- 51" wide gallery panel accommodates two 24" deep surface while the 63" wide accommodates two 30" deep surfaces and 75" wide two 36" deep surfaces.
- Please specify LP laminate finish and PVC edge finish.
- If a wood grain laminate is chosen, grain direction run horizontally.
- Edged in PVC on exposed top edge only and self edged on the three other.

PRODUCT CODE	PRICE LP	SIZE /INCHES			WEIGHT LBS	VOL FT ³
		H	W	D		
B3LMP4251	880	42	51	1	56.07	1.24
B3LMP4263	958	42	63	1	68.91	1.53
B3LMP4275	1041	42	75	1	81.76	1.82
B3LMP5051	995	50	51	1	67.06	1.48
B3LMP5063	1090	50	63	1	82.41	1.82
B3LMP5075	1201	50	75	1	97.76	2.17
B3LMP5451	1024	54	51	1	72.55	1.59
B3LMP5463	1123	54	63	1	89.15	1.97
B3LMP5475	1237	54	75	1	105.74	2.34

B3LSMP - Middle of Run Single Gallery Panel in T Configuration, with Connectors for Additional Gallery Panels

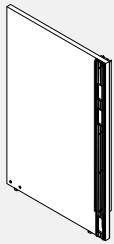

- Provides floor standing support at the middle of a panel run.
- Attached in the middle of a straight Boulevard 1 or System 3 panel run with capture strips to form a T configuration.
- Connections are on the exposed edge (for Gallery Panel) and near the opposite end on both interior and exterior faces (for Boulevard Panels).
- Compatible with left hand gallery panels (B3LXPLxxxx and B3LXPLxxxxNC, B3L2PLxxxx and B3L3PLxxxx) only.
- Includes all attachment hardware and glides.
- Total height is inclusive of panel glides extended to their full height.
- 27" wide gallery panel accommodates a 24" deep surface while the 33" wide accommodates a 30" deep surface and 39" wide a 36" deep surface.
- Please specify LP laminate finish and PVC edge finish.
- If a wood grain laminate is chosen, grain direction run horizontally.
- Edged in PVC on two exposed edges, self edged on connecting to gallery panel edge and the bottom.

PRODUCT CODE	PRICE LP	SIZE /INCHES			WEIGHT LBS	VOL FT ³
		H	W	D		
B3LSMP4227	717	42	27	1	30.33	0.66
B3LSMP4233	757	42	33	1	36.75	0.80
B3LSMP4239	784	42	39	1	43.17	0.95
B3LSMP5027	795	50	27	1	36.32	0.78
B3LSMP5033	843	50	33	1	43.99	0.95
B3LSMP5039	886	50	39	1	51.67	1.13
B3LSMP5427	819	54	27	1	39.31	0.84
B3LSMP5433	868	54	33	1	47.61	1.03
B3LSMP5439	913	54	39	1	55.91	1.22

B3LXPL • Left Gallery Panel Extension, with Connectors for Additional Gallery Panels

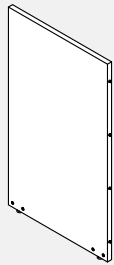

- Provides floor standing support while extending the Gallery Panels run.
- Attaches to the left edge of a Gallery Panel by the pin connectors to allow for additional Gallery Panels to be added on the left side.
- Pin connectors on the right edge and modular connectors on the left edge of the interior face.
- The right side is compatible with Gallery Panels (B3LEPxxx, B3LSEPL, B3LMPxxx, B3LSMP and B3LXPLxxx) only.
- The left side is compatible with left hand Gallery Panels (B3LXPLxxxx and B3LX-PLxxxxNC, B3L2PLxxxx and B3L3PLxxxx) only.
- Includes all attachment hardware and glides.
- Total height is inclusive of panel glides extended to their full height.
- Please specify LP laminate finish and PVC edge finish.
- If a wood grain laminate is chosen, grain direction run horizontally.
- Edged in PVC on exposed top edge only and self edges on the three other.
- Edged in PVC on two exposed edges, self edged on connecting to gallery panel edge and the bottom.

PRODUCT CODE	PRICE LP	SIZE /INCHES			WEIGHT LBS	VOL FT ³
		H	W	D		
B3LXPL4224	260	42	24	1	25.83	0.58
B3LXPL4230	299	42	30	1	32.26	0.73
B3LXPL4236	338	42	36	1	38.68	0.88
B3LXPL4242	376	42	42	1	45.11	1.02
B3LXPL4248	415	42	48	1	51.53	1.17
B3LXPL5024	309	50	24	1	30.83	0.69
B3LXPL5030	357	50	30	1	38.51	0.87
B3LXPL5036	406	50	36	1	46.18	1.04
B3LXPL5042	453	50	42	1	53.86	1.22
B3LXPL5048	502	50	48	1	61.53	1.39
B3LXPL5424	319	54	24	1	33.34	0.75
B3LXPL5430	369	54	30	1	41.64	0.94
B3LXPL5436	417	54	36	1	49.94	1.13
B3LXPL5442	466	54	42	1	58.24	1.31
B3LXPL5448	518	54	48	1	66.54	1.50

B3LXPR • Right Gallery Panel Extension, with Connectors for Additional Gallery Panels



- Provides floor standing support while extending the Gallery Panels run.
- Attaches to the right edge of a Gallery Panel by the pin connectors to allow for additional Gallery Panels to be added on the right side.
- Pin connectors on the right edge and modular connectors on the left edge of the interior face.
- The right side is compatible with right hand Gallery Panels (B3LXPRxxxx and B3LXPRxxxxNC, B3L2PRxxxx and B3L3PRxxxx) only.
- The left side is compatible with Gallery Panels (B3LEPxxx, B3LSEPRxxx, B3LMPxxx and B3LXPRxxx) only.
- Includes all attachment hardware and glides.
- Total height is inclusive of panel glides extended to their full height.
- Please specify LP laminate finish and PVC edge finish.
- If a wood grain laminate is chosen, grain direction run horizontally.
- Edged in PVC on exposed top edge only and self edges on the three other.

PRODUCT CODE	PRICE LP	SIZE /INCHES			WEIGHT LBS	VOL FT ³
		H	W	D		
B3LXPR4224	260	42	24	1	25.83	0.58
B3LXPR4230	299	42	30	1	32.26	0.73
B3LXPR4236	338	42	36	1	38.68	0.88
B3LXPR4242	376	42	42	1	45.11	1.02
B3LXPR4248	415	42	48	1	51.53	1.17
B3LXPR5024	309	50	24	1	30.83	0.69
B3LXPR5030	357	50	30	1	38.51	0.87
B3LXPR5036	406	50	36	1	46.18	1.04
B3LXPR5042	453	50	42	1	53.86	1.22
B3LXPR5048	502	50	48	1	61.53	1.39
B3LXPR5424	319	54	24	1	33.34	0.75
B3LXPR5430	369	54	30	1	41.64	0.94
B3LXPR5436	417	54	36	1	49.94	1.13
B3LXPR5442	466	54	42	1	58.24	1.31
B3LXPR5448	518	54	48	1	66.54	1.50

B3LXPL-NC • Left Gallery Panel Extension, No Connectors for Additional Gallery Panels

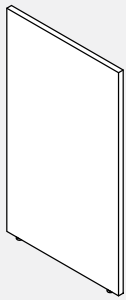

- Provides floor standing support while enclosing the end of a Gallery Panel left run.
- Attached to the left edge of a Gallery Panel by the pin connectors to finish the run.
- Pin connectors are on the right edge of the interior face.
- Compatible with gallery panels (B3LEPxxxx, B3LSEPLxxxx, B3LMPxxxx, B3LMPxxxx and B3LXPLxxxx) only.
- Includes all attachment hardware and glides.
- Total height is inclusive of panel glides extended to their full height.
- Please specify LP laminate finish and PVC edge finish.
- If a wood grain laminate is chosen, grain direction run horizontally.
- Edged in PVC on two exposed edges, self edged on connecting to gallery panel edge and the bottom.

PRODUCT CODE	PRICE LP	SIZE /INCHES			WEIGHT LBS	VOL FT ³
		H	W	D		
B3LXPL4212NC	142	42	12	1	12.95	0.29
B3LXPL4224NC	252	42	24	1	25.8	0.58
B3LXPL4230NC	291	42	30	1	32.22	0.73
B3LXPL4236NC	330	42	36	1	38.65	0.88
B3LXPL4242NC	370	42	42	1	45.07	1.02
B3LXPL4248NC	408	42	48	1	51.5	1.17
B3LXPL5012NC	177	50	12	1	15.45	0.35
B3LXPL5024NC	303	50	24	1	30.8	0.69
B3LXPL5030NC	350	50	30	1	38.47	0.87
B3LXPL5036NC	398	50	36	1	46.15	1.04
B3LXPL5042NC	448	50	42	1	53.82	1.22
B3LXPL5048NC	495	50	48	1	61.5	1.39
B3LXPL5412NC	177	54	12	1	16.7	0.38
B3LXPL5424NC	312	54	24	1	33.3	0.75
B3LXPL5430NC	362	54	30	1	41.6	0.94
B3LXPL5436NC	410	54	36	1	49.9	1.13
B3LXPL5442NC	460	54	42	1	58.2	1.31
B3LXPL5448NC	509	54	48	1	66.5	1.50

B3LXPR-NC • Right Gallery Panel Extension, No Connectors for Additional Gallery Panels

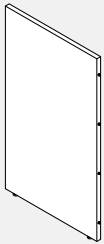

- Provides floor standing support while enclosing the end of a Gallery Panel right run.
- Attached to the right edge of a Gallery Panel by the pin connectors to finish the run.
- Pin connectors are on the left edge of the interior face.
- Compatible with gallery panels (B3LEPxxxx, B3LSEPRxxxx, B3LMPxxxx and B3LXPRxxxx) only.
- Includes all attachment hardware and glides.
- Total height is inclusive of panel glides extended to their full height.
- Please specify LP laminate finish and PVC edge finish.
- If a wood grain laminate is chosen, grain direction run horizontally.
- Edged in PVC on two exposed edges, self edged on connecting to gallery panel edge and the bottom.

PRODUCT CODE	PRICE LP	SIZE /INCHES			WEIGHT LBS	VOL FT ³
		H	W	D		
B3LXPR4212NC	142	42	12	1	12.95	0.29
B3LXPR4224NC	252	42	24	1	25.8	0.58
B3LXPR4230NC	291	42	30	1	32.22	0.73
B3LXPR4236NC	330	42	36	1	38.65	0.88
B3LXPR4242NC	370	42	42	1	45.07	1.02
B3LXPR4248NC	408	42	48	1	51.5	1.17
B3LXPR5012NC	177	50	12	1	15.45	0.35
B3LXPR5024NC	303	50	24	1	30.8	0.69
B3LXPR5030NC	350	50	30	1	38.47	0.87
B3LXPR5036NC	398	50	36	1	46.15	1.04
B3LXPR5042NC	448	50	42	1	53.82	1.22
B3LXPR5048NC	495	50	48	1	61.5	1.39
B3LXPR5412NC	177	54	12	1	16.7	0.38
B3LXPR5424NC	312	54	24	1	33.3	0.75
B3LXPR5430NC	362	54	30	1	41.6	0.94
B3LXPR5436NC	410	54	36	1	49.9	1.13
B3LXPR5442NC	460	54	42	1	58.2	1.31
B3LXPR5448NC	509	54	48	1	66.5	1.50

B3L2PR • Right Gallery Panel End of Run Return

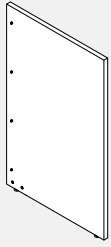

- Provides floor standing support while enclosing the end of a Gallery Panel run.
- Attaches at the Gallery Panel right edge with connectors to form an L configuration.
- Connections to Gallery Panel are on the interior face near it's left end.
- Compatible with Gallery Panels (B3LEPxxxx, B3LSEPRxxxx, B3LMPxxxx and B3LX-PRxxxx) only.
- Includes all attachment hardware and glides.
- Total height is inclusive of panel glides extended to their full height.
- 25" wide gallery panel accomodates a 24" deep surface while the 31" wide accomo- dates a 30" deep surface and 37" wide a 36" deep surface.
- Please specify LP laminate finish and PVC edge finish.
- If a wood grain laminate is chosen, grain direction run horizontally.
- Edged in PVC on three exposed edges and self edged on the bottom edge.

PRODUCT CODE	PRICE LP	SIZE /INCHES			WEIGHT LBS	VOL FT³
		H	W	D		
B3L2PR4213	153	42	13	1	14.02	0.32
B3L2PR4225	291	42	25	1	26.87	0.61
B3L2PR4231	330	42	31	1	33.29	0.75
B3L2PR4237	357	42	37	1	39.72	0.90
B3L2PR5013	192	50	13	1	16.73	0.38
B3L2PR5025	350	50	25	1	32.08	0.72
B3L2PR5031	398	50	31	1	39.75	0.90
B3L2PR5037	441	50	37	1	47.43	1.07
B3L2PR5413	192	54	13	1	18.08	0.41
B3L2PR5425	362	54	25	1	34.68	0.78
B3L2PR5431	410	54	31	1	42.98	0.97
B3L2PR5437	454	54	37	1	51.28	1.16

B3L2PL • Left Gallery Panel End of Run Return

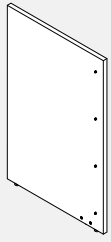

- Provides floor standing support while enclosing the end of a gallery panel run.
- Attaches at the Gallery Panel left edge with connectors to form an L configuration.
- Connections to Gallery Panel are on the interior face near it's right end .
- Compatible with Gallery Panels (B3LEPxxxx, B3LSEPLxxxx, B3LMPxxxx, B3LS- MPxxxx and B3LXPLxxxx) only.
- Includes all attachment hardware and glides.
- Total height is inclusive of panel glides extended to their full height.
- 25" wide gallery panel accomodates a 24" deep surface while the 31" wide accomo- dates a 30" deep surface and 37" wide a 36" deep surface.
- Please specify LP laminate finish and PVC edge finish.
- If a wood grain laminate is chosen, grain direction run horizontally.
- Edged in PVC on three exposed edges and self edged on the bottom edge.

PRODUCT CODE	PRICE LP	SIZE /INCHES			WEIGHT LBS	VOL FT³
		H	W	D		
B3L2PL4213	153	42	13	1	14.02	0.32
B3L2PL4225	291	42	25	1	26.87	0.61
B3L2PL4231	330	42	31	1	33.29	0.75
B3L2PL4237	357	42	37	1	39.72	0.90
B3L2PL5013	192	50	13	1	16.73	0.38
B3L2PL5025	350	50	25	1	32.08	0.72
B3L2PL5031	398	50	31	1	39.75	0.90
B3L2PL5037	441	50	37	1	47.43	1.07
B3L2PL5413	192	54	13	1	18.08	0.41
B3L2PL5425	362	54	25	1	34.68	0.78
B3L2PL5431	410	54	31	1	42.98	0.97
B3L2PL5437	454	54	37	1	51.28	1.16

B3L3PL • Left Gallery Panel End of Run 3-Way Return

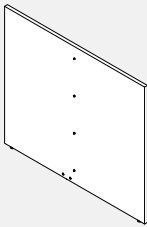

- Provides floor standing support while enclosing the end of a Gallery Panel run.
- Attaches to the Gallery Panel left edge with connectors to form an T configuration.
- Connections to Gallery Panel are on the interior face in the middle.
- Compatible with Gallery Panels (B3LEPxxxx, B3LSEPLxxxx, B3LMPxxxx, B3LS- MPxxxx and B3LXPLxxxx) only.
- Includes all attachment hardware and glides.
- Total height is inclusive of panel glides extended to their full height.
- 49" wide gallery panel accomodates two 24" deep surfaces while the 61" wide accomodates two 30" deep surface and 73" wide two 36" deep surface.
- Please specify LP laminate finish and PVC edge finish.
- If a wood grain laminate is chosen, grain direction run horizontally.
- Edged in PVC on three exposed edges and self edged on the bottom edge.

PRODUCT CODE	PRICE LP	SIZE /INCHES			WEIGHT LBS	VOL FT³
		H	W	D		
B3L3PL4225	229	42	25	1	26.87	0.61
B3L3PL4249	396	42	49	1	52.57	1.19
B3L3PL4261	524	42	61	1	65.41	1.48
B3L3PL4273	609	42	73	1	78.26	1.77
B3L3PL5025	286	50	25	1	32.08	0.72
B3L3PL5049	543	50	49	1	62.77	1.42
B3L3PL5061	639	50	61	1	78.12	1.77
B3L3PL5073	749	50	73	1	93.47	2.11
B3L3PL5425	286	54	25	1	34.68	0.78
B3L3PL5449	559	54	49	1	67.88	1.53
B3L3PL5461	658	54	61	1	84.48	1.91
B3L3PL5473	773	54	73	1	101.08	2.28

B3L3PR • Right Gallery Panel End of Run 3-Way Return

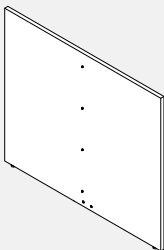

- Provides floor standing support while enclosing the end of a Gallery Panel run.
- Attaches to the Gallery Panel right edge with connectors to form an T configuration.
- Connections to Gallery Panel are on the interior face in the middle.
- Compatible with gallery panels (B3LEPxxxx, B3LSEPRxxxx, B3LMPxxxx and B3LXPRxxxx) only.
- Includes all attachment hardware and glides.
- Total height is inclusive of panel glides extended to their full height.
- 49" wide gallery panel accomodates two 24" deep surfaces while the 61" wide accomodates two 30" deep surface and 73" wide two 36" deep surface.
- Please specify LP laminate finish and PVC edge finish.
- If a wood grain laminate is chosen, grain direction run horizontally.
- Edged in PVC on three exposed edges and self edged on the bottom edge.

PRODUCT CODE	PRICE LP	SIZE /INCHES			WEIGHT LBS	VOL FT³
		H	W	D		
B3L3PR4225	229	42	25	1	26.87	0.61
B3L3PR4249	396	42	49	1	52.57	1.19
B3L3PR4261	524	42	61	1	65.41	1.48
B3L3PR4273	609	42	73	1	78.26	1.77
B3L3PR5025	286	50	25	1	32.08	0.72
B3L3PR5049	543	50	49	1	62.77	1.42
B3L3PR5061	639	50	61	1	78.12	1.77
B3L3PR5073	749	50	73	1	93.47	2.11
B3L3PR5425	286	54	25	1	34.68	0.78
B3L3PR5449	559	54	49	1	67.88	1.53
B3L3PR5461	658	54	61	1	84.48	1.91
B3L3PR5473	773	54	73	1	101.08	2.28

B3HLPBB01 • Gallery Panel Bottom Inline Bracket

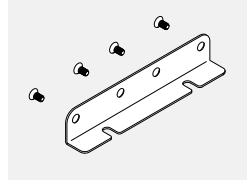

- Gallery Panel Bottom Inline Bracket connects two Gallery Panels at the bottom with screws.
- Available in standard paint colors.

PRODUCT CODE	PRICE	SIZE /INCHES			WEIGHT LBS	VOL FT ³
		H	W	D		
B3HLPBB01	35	7	1.5	8	1	0.5

B3HLPCB01 • Gallery Panel Corner Bracket

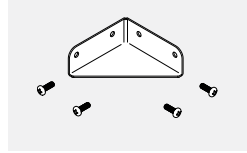

- Gallery Panel Corner Bottom bracket connects two Gallery Panels at 90 degrees.
- Available in standard paint colors.

PRODUCT CODE	PRICE	SIZE /INCHES			WEIGHT LBS	VOL FT ³
		H	W	D		
B3HLPCB01	34	7	1.5	4	4	0.5

B3PMP-GI-W • Privacy Glass for 1" Laminate Panels

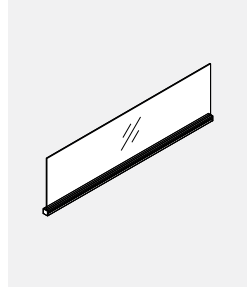

- Privacy glass integrated with aluminum top trim.
- Attaches on top of gallery panels to add privacy or divide space.
- Includes aluminum trim with channel, end caps and glass tile.
- Top rail may also be used to hang accessories.
- Glass and attachment hardware ship separately.
- Please specify standard paint finish for the channel.
- Standard in clear (CLR) or frosted (FRST).

PRODUCT CODE	PRICE		SIZE /INCHES			WEIGHT LBS	VOL FT ³
	CLR	FRST	H	W	D		
B3PMP24GI8W	201	251	8	24	1	4.84	0.11
B3PMP30GI8W	219	276	8	30	1	6.06	0.14
B3PMP36GI8W	235	291	8	36	1	7.28	0.17
B3PMP42GI8W	251	313	8	42	1	8.5	0.19
B3PMP48GI8W	262	327	8	48	1	9.72	0.22
B3PMP24GI16W	201	251	16	24	1	8.92	0.22
B3PMP30GI16W	219	276	16	30	1	11.17	0.28
B3PMP36GI16W	235	291	16	36	1	13.43	0.33
B3PMP42GI16W	251	313	16	42	1	15.68	0.39
B3PMP48GI16W	262	327	16	48	1	17.92	0.44

B3PFD-W • Felt divider for 1" Laminate Panels

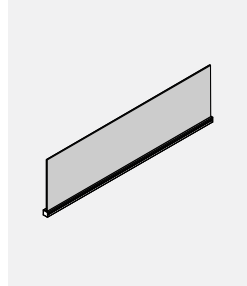

- Privacy felt integrated with aluminum top trim.
- Attaches on top of gallery panels to add privacy or divide space.
- Includes aluminum trim with channel, end caps and felt tile.
- Top rail may also be used to hang accessories.
- Felt and attachment hardware ship separately.
- Please specify standard paint finish for the channel.
- Please specify standard felt finish.

PRODUCT CODE	PRICE		SIZE /INCHES			WEIGHT LBS	VOL FT ³
	CLR	FRST	H	W	D		
B3PFD0824W	72		8	24	1	1.32	0.11
B3PFD0830W	88		8	30	1	1.65	0.14
B3PFD0836W	102		8	36	1	1.99	0.17
B3PFD0842W	114		8	42	1	2.32	0.19
B3PFD0848W	170		8	48	1	2.65	0.22
B3PFD0854W	183		8	54	1	2.98	0.25
B3PFD0860W	199		8	60	1	3.32	0.28
B3PFD0866W	210		8	66	1	3.65	0.31
B3PFD0872W	238		8	72	1	3.98	0.33
B3PFD1624W	83		16	24	1	1.83	0.22
B3PFD1630W	98		16	30	1	2.3	0.28
B3PFD1636W	116		16	36	1	2.76	0.33
B3PFD1642W	130		16	42	1	3.22	0.39
B3PFD1648W	193		16	48	1	3.68	0.44
B3PFD1654W	210		16	54	1	4.14	0.50
B3PFD1660W	226		16	60	1	4.61	0.56
B3PFD1666W	238		16	66	1	5.07	0.61
B3PFD1672W	271		16	72	1	5.53	0.67

Electrical

Affordability and widespread availability of wireless networking is gradually diminishing the need for extensive cable capacity housing. However, as our desk top equipment still requires electricity, providing access to power from within a work station is an integral part of any work place design.

The Global Contract family of power components has been assembled to address a variety of common requirements as well as to satisfy specific customer needs and budgets.

Global Contract can now offer the option of 3 duplex per panel, please contact your Customer Service Representative.

Direct Access:

When office equipment plugs directly into a wall or raised floor power source, cable troughs, as well the Boulevard panel internal cavity serve the purpose of organizing cables.

Extensions:

Keeping minimal installation costs in mind, the next natural step is the employment of fused and surge protected power bars, worksurface-clamped receptacles or floor standing power towers.

Four circuit power systems:

In the absence of a raised floor, or when office equipment is to be installed further away from wall outlets, the Boulevard panel or Bridges unit the building power supply - office equipment gap by distributing power at either floor or desk height level, or both.

While Boulevard panels are capable of surrounding a given work station with power and data outlets at multiple levels, it is important to remember that the most economical way of providing four-circuit power distribution is if the harness, junction box and receptacle system remained within the central spine structure. The cost savings here come from a number and lengths of individual connecting power harnesses.

Should there be a need to branch power from Boulevard or central spine onto adjacent, perpendicular work surfaces, the employment of fused and surge protected power bars will assist in keeping the cost under control.

However, the very same, 4-circuit system is capable of delivering a considerable amount of power as there can be up to six, 8 wire-4 circuit systems accommodated within System3 pass-thru panel. For instance: three systems at the floor level and two systems at the desk height.

Various ceiling or floor level power entry feeds are available. See the following pages for individual component description and technical specifications.

Technical Information

Wire Schematic

4-2-2 Wiring Schematic

8-Wire Shared Neutral

"3+1" -3 Utility circuits, 1 dedicated circuit.

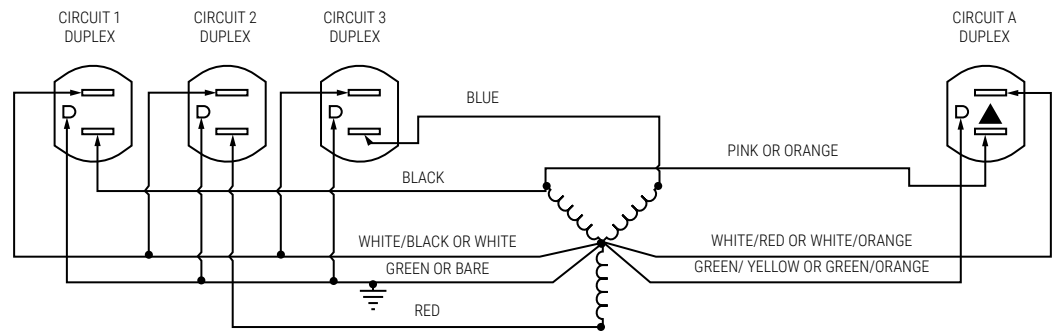

8 Wires

4 Lines (12 ga.)
2 Neutrals (10 ga.)
2 Grounds (12 ga.)

4 Circuits

3 Utility Circuits
1 Dedicated Circuits

Receptacles

Duplex – Up to 6 duplex
receptacles per circuit
(Up to 48 infeed)

Specifications

System rated for connection to a grounded 120/240 V, single phase*, 20A, 60Hz or 120/208 V, 3 phase, 20A, 60Hz branch circuit for U.S. and 15A if product is marked with a C-UL Mark. Outlets rated 15A max.

* When connected to Single Phase. Only
Circuit 1,3 & A are available.

UL Recognised CSA Certified

Warning: It is recommended that installation of the electrical harness be made under the supervision of a licensed electrician in accordance with applicable codes and regulations.

Special Note: Always determine that harness is electrically connected to only one power supply.

STEP-BY-STEP SPECIFICATION - 8 WIRE ELECTRICAL FOR BOULEVARD 1 AND RACEWAY PANELS

STEP 1: Determine the location of the source power entry entering the panel through a post.

a) From the floor:

i) Choose from a selection of single or double Base Feeds (BE81BF721, BE81BF722, BE81BF1441, BE81BF1442) to bring the power from the floor to the raceway channel.

ii) Select a post adjacent to the panel (or panels if using a Double Base Feed) to which the end of the Base Feed will be attached. This panel requires a Power Distribution Housing and must be located next to the post through which the Base Feed is entering.

Note: If it is not practical to have a Power Distribution Housing in a panel adjacent to the selected Base Feed Post, use a BE8CPxxHJ Housing-to-Jumper Pass-Thru Cable to transition through the adjacent non-powered panel(s) that are between the Base Feed Post and the first powered panel. The length of the cable will equal the combined width of the non-powered panel(s).

b) From the Ceiling:

i) Choose from a selection of single or double Ceiling Feeds (BE81CF1201, BE81CF120-2, BE81CF1441, BE81CF1442) to bring the power from the ceiling to the raceway.

ii) Select a post adjacent to the panel (or panels if using a Double Ceiling Feed) to which the Ceiling Feed will be attached. This panel requires a Power Distribution Housing and must be located next to the post through which the Ceiling Feed is entering.

STEP 2: Determine which panels are to be powered.

a) Use a BE81D Concealed Desk Height Power Distribution Housing or a BE8U2D Face Mount Desk Height Power Distribution Housing that corresponds with the width of each panel selected to be powered.

Note: Specify Face Mount Raceway Covers for panels that contain BE8U2D Face Mount Desk Height Power Distribution Housings.

STEP 3: Connect power to the panels.

a) Use a BE8JC16 Jumper between two adjacent powered panels.

b) Use a BE8JC20 Jumper between two powered panels separated by a post.

c) **Use a BE8JM19 Shielded Mesh Jumper between two powered panels separated by a post.**

d) Use a BE8CPxxHJ Housing-to-Jumper Pass-Thru Cable to electrically connect a BE8JM19 Shielded Mesh Jumper and a powered panel when the two are separated by one or more non-powered panels in a straight line application only.

i) The length of the BE8CPxxHJ Housing-to-Jumper Pass-Thru Cable will equal the combined width of the non-powered panel(s).

e) Use a BE8CPxxHH Housing-to-Housing Pass-Thru Cable to electrically connect two powered panel separated by one or more non-powered panels in a straight line application only.

i) The length of the Pass-Thru Cable corresponds with the width(s) of the non-powered panels that separate two powered panels plus 16" (the termination blocks of the Power Distribution Housing are 8" in from the edge of the powered panel), plus 4" for each post.

f) Connect two jumpers or cables together by using the I-Connector BE8CI1. This functions as a female-female adapter and it allows the male ends of jumpers and pass-thru cables to connect together.

STEP 4: Designate which circuit each duplex is to tap into.

a) Each powered panel has four (4) potential locations for duplex receptacles - 2 per side. (Exception: 24" wide panel has only two (2) potential locations - 1 per side, 18" wide panel has no locations for receptacles).

b) At each location there is a choice of four (4) circuit options. Select the circuit option for each location.

Circuit Selections : Circuits 1, 2, and 3 are utility circuits, all sharing a ground and a neutral. Circuit A is a dedicated circuit with its own ground and neutral.

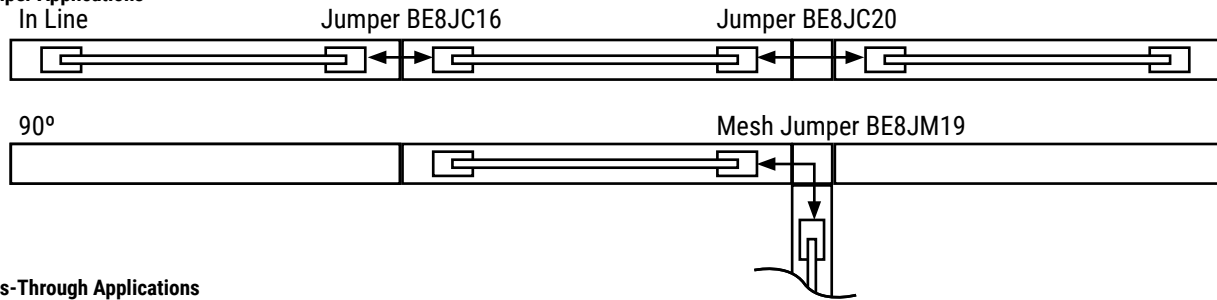
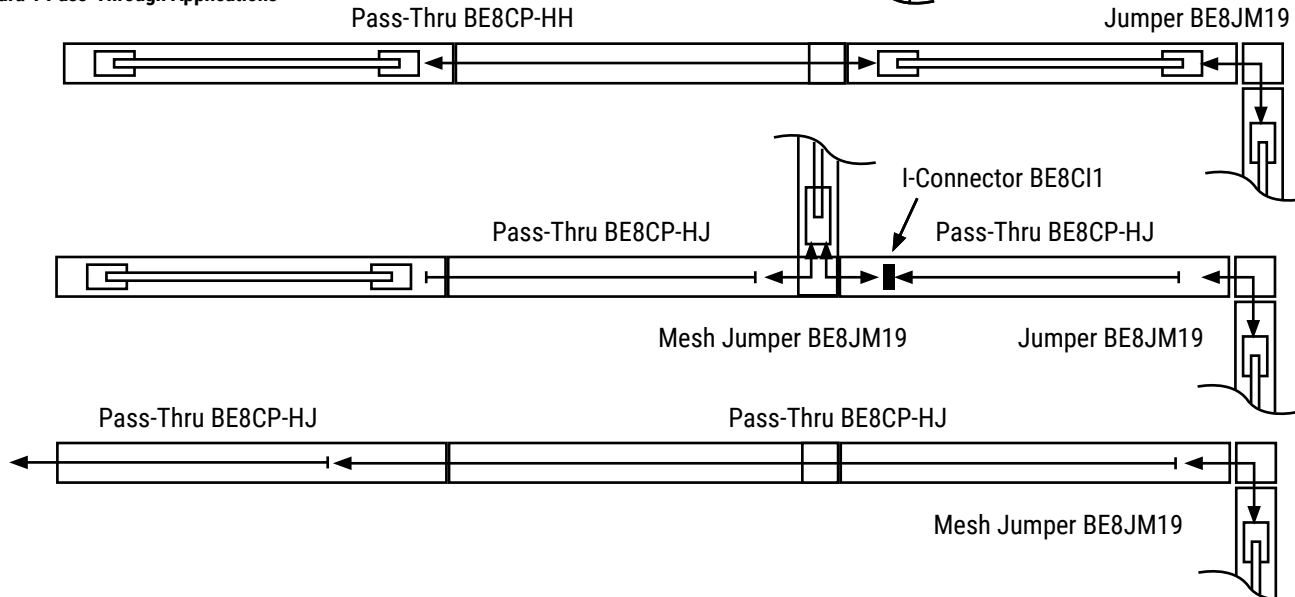
SPECIFICATION APPLICATIONS**Boulevard 1 Jumper Applications****Boulevard 1 Pass-Through Applications**

STEP-BY-STEP SPECIFICATION - 8 WIRE ELECTRICAL FOR BOULEVARD SYSTEM 3 BASE RACEWAY

STEP 1: Determine the location of the source power entry entering the panel.

- a. At the base of a panel:
 - i. Use a BE8BFxx Base Feed.
 - ii. Select the panel to which the Base Feed will be attached. This panel requires a BE83D Power Distribution Housing.
 - iii. Select the side of the panel and the receptacle outlet to which the Base Feed is to be attached.
- b. From the ceiling:
 - i. Use a BE8CFxx-1or -2 (single or double).
 - ii. Select the post through which to feed the Ceiling Feed.
 - iii. One panel adjacent to the selected post requires a BE83D Power Distribution Housing. Attach the Ceiling Feed to the nearest end of the Power Distribution Housing.

Note: If it is not practical to have a Power Distribution Housing in a panel adjacent to the selected Ceiling Feed Post, use a BE8CPxxHJ Housing-to-Jumper Pass-Thru Cable to transition through the adjacent non-powered panel(s) that are between the Ceiling Feed Post and the first powered panel. The length of the cable will equal the combined width of the non-powered panel(s).

- c. At the base of an adjoining panel:
 - i. Use a BE83BFR72 Raceway Entry Base Feed
 - ii. Select a non-powered panel adjacent to the panel with a Power Distribution Housing.
 - iii. Choose a duplex opening on either side of the panel to insert and attach the Raceway Entry Base Feed at that point.
 - iv. The Raceway Entry Base Feed will attach to the nearest end of the Power Distribution Housing (similar to the Ceiling Feed attachment).

STEP 2: Determine which panels are to be powered.

- a. Use a BE83D Power Distribution Housing that corresponds with the width of the selected panel.

STEP 3: Connect power to the panels.

- a. Use a BE8JC16 Jumper between two adjacent powered panels.
- b. Use a BE8JC20 Jumper between two powered panels separated by a post.
- c. Use a BE8CPxxHH Housing-to-Housing Pass-Thru Cable to connect two powered panels separated by one or more non-powered panels. i. The length of the Pass-Thru Cable corresponds with the width(s) of the non-powered panels that separate two powered panels plus 16" (the termination blocks of the Power Distribution Housing are 8" in from the edge of the powered panel plus 4" for each post).

STEP 4: Designate which circuit each duplex is to tap into.

- a. Each powered panel has four (4) potential locations for duplex receptacles - 2 per side. (Exception: 24" wide panel has only two (2) potential locations - 1 per side, 18" wide panel has no locations for receptacles).
- b. At each location there is a choice of four (4) circuit options. Select the circuit option for each location.

Circuit Selections : Circuits 1, 2, and 3 are utility circuits, all sharing a ground and a neutral. Circuit A is a dedicated circuit with its own ground and neutral.

SPECIFICATION APPLICATIONS

Boulevard System 3 Jumper Applications

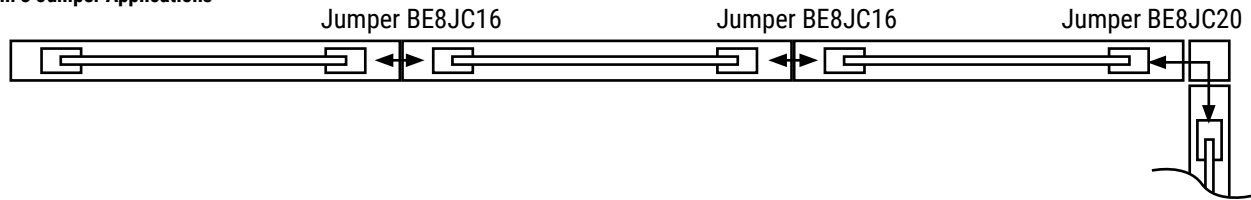

Boulevard System 3 Jumper Applications

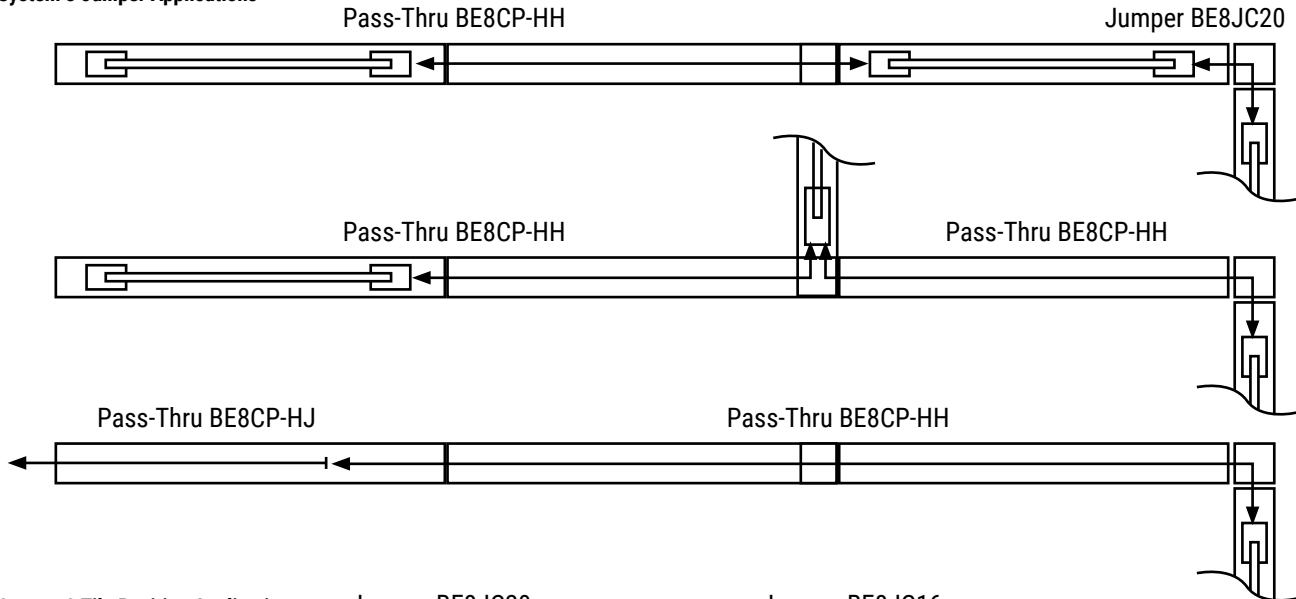

Boulevard System 3 Tile Position Application

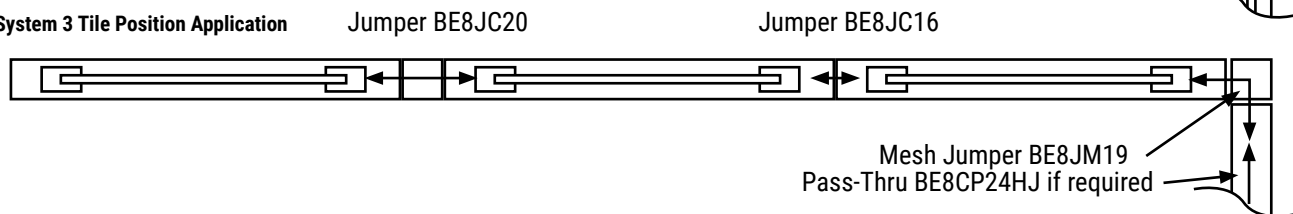

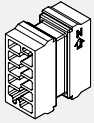
BE8CI-1 • "I" Connector

- Connects two Pass Thru Cables.
- Inline coupler used to connect two BE8CPxxHH Pass-Thru Cables.

PRODUCT CODE	PRICE	SIZE/ INCHES			WEIGHT VOL	
		H	W	D	LBS	FT ³
BE8CI1	85	1.5	1.5	4.625	0.06	0.03

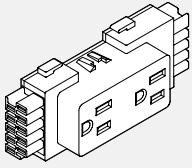
BE8D • Duplex Receptacles

- Snaps into Power Distribution Housing.
- Up to 6 duplex receptacles per circuit.
- BE8D1 = Circuit #1 (utility circuit)
- BE8D2 = Circuit #2 (utility circuit)
- BE8D3 = Circuit #3 (utility circuit)
- BE8DA - Circuit #A (dedicated circuit)

PRODUCT CODE	PRICE	SIZE/ INCHES			WEIGHT VOL	
		H	W	D	LBS	FT ³
BE8D1	35	2	4.625	1.25	0.10	0.01
BE8D2	35	2	4.625	1.25	0.10	0.01
BE8D3	35	2	4.625	1.25	0.10	0.01
BE8DA	35	2	4.625	1.25	0.10	0.01

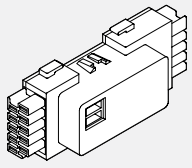
BE8D • USB Receptacles

- Snaps into Power Distribution Housing.
- USB charging module provides convenient charging power access through dual ports on face of receptacles.
- Two USB ports.
- 2 amp output, considered as circuit #1.

PRODUCT CODE	PRICE	SIZE/ INCHES			WEIGHT VOL	
		H	W	D	LBS	FT ³
BE8DU1-B	238	2	4.625	1.25	0.10	0.01
BE8DU1-W	238	2	4.625	1.25	0.10	0.01

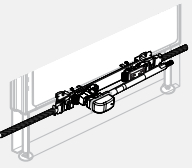
BE83BF • Reversible Base Feed (Boulevard System 3 only)

- Provides single power entry from floor circuit to raceway.
- Takes the place of a duplex receptacle by connecting to the base raceway channel of a Boulevard System 3 panel.
- BE83BF72 includes 72" long liquid-tite conduit, BE83BF144 includes 144" long liquid-tite conduit.
- Must be hard wired to power source by a licensed electrician.

PRODUCT CODE	PRICE	SIZE/ INCHES			WEIGHT VOL	
		H	L	D	LBS	FT ³
BE83BF72	353	3	72	3	3.82	2
BE83BF144	450	3	144	3	6.98	2

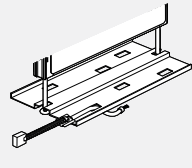
BE83BFR72 • Raceway Entry Base Feed (Boulevard System 3 only)

- Brings power to an adjacent panel by entering a non-powered raceway of a Boulevard System 3 panel through a duplex opening.
- Includes 72" long liquid-tite conduit.
- Must be hard wired to power source by a licensed electrician.

PRODUCT CODE	PRICE	SIZE/ INCHES			WEIGHT VOL	
		H	L	D	LBS	FT ³
BE83BFR72	437	3	88	3	4.82	2

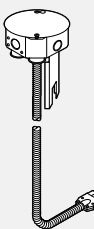
BE8CF-1 • Ceiling Feed - Single

- Provides single power entry from ceiling, through post and into raceway channel.
- Power entry cable penetrates 8" into a panel and plugs into either a Power Distribution Housing or BE8CPxxHJ Pass-Thru Harness.
- Specify Post Extension separately.
- Must be hard wired to power source by a licensed electrician.

PRODUCT CODE	PRICE	SIZE/ INCHES			WEIGHT VOL	
		H	L	D	LBS	FT ³
BE8CF1201	353	6	120	6	5.24	2
BE8CF1441	479	6	144	6	5.96	2

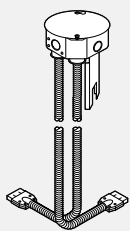
BE8CF-2 • Ceiling Feed - Double

- Provides dual power entry from ceiling, through post and into raceway channel.
- Power entry cable penetrates 8" into a panel and plugs into either a Power Distribution Housing or a BE8CPxxHJ Pass-Thru Harness.
- Use 1) In middle of run to distribute power in two directions.
2) At beginning of run where second Ceiling Feed harness is connected to BE8CPxxHJ and distributes power underneath Power Distribution Housing to pick-up second circuit grouping in long panel run.
- Specify Post Extension separately.
- Must be hard wired to power source by a licensed electrician.

PRODUCT CODE	PRICE	SIZE/ INCHES			WEIGHT VOL	
		H	L	D	LBS	FT ³
BE8CF1202	620	6	120	3	5.24	2
BE8CF1442	701	6	144	3	5.96	2

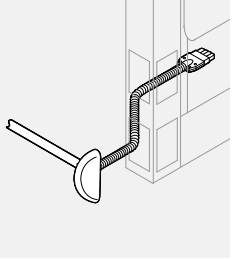
BE81BF-1 • Base Feed - Single (Boulevard 1 only)

- Provides single power entry from floor, through post and into Boulevard 1 raceway channel.
- Power entry cable penetrates 8" into a panel and plugs into either a Power Distribution Housing or a BE8CPxxHJ Pass-Thru Harness.
- Power entry dome available in black only, but "Capture Strip" connector will match the post colour as standard.
- 2 1/2" clearance in depth and 5 1/2" away from any obstructions required from power entry point.
- Comes with 32" harness attached. Liquid-tite whip 72" and 144".
- Must be hard wired to power source by a licensed electrician.

PRODUCT CODE	PRICE	SIZE/ INCHES			WEIGHT VOL	
		H	L	D	LBS	FT ³
BE81BF721	349	6	107	3	3.82	2
BE81BF1441	466	6	179	3	5.96	2

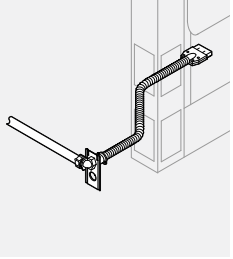
BE81BF-1FL • Base Feed - Single (Boulevard 1 only)

- Provides single power entry from floor, through post and into Boulevard 1 raceway channel.
- Power entry cable penetrates 8" into a panel and plugs into either a Power Distribution Housing or a BE8CPxxHJ Pass-Thru Harness.
- Power entry plate available in black only, but "Capture Strip" connector will match the post colour as standard.
- 2 1/2" clearance in depth and 5 1/2" away from any obstructions required from power entry point.
- Comes with 32" harness attached. Liquid-tite whip 72" and 144".
- Must be hard wired to power source by a licensed electrician.

PRODUCT CODE	PRICE	SIZE/ INCHES			WEIGHT VOL	
		H	L	D	LBS	FT ³
BE81BF721FL	349	6	107	3	3.82	2
BE81BF1441FL	466	6	179	3	3.82	2

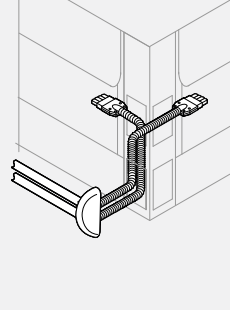
BE81BF-2 • Base Feed - Double (Boulevard 1 only)

- Provides dual power entry from floor, through post and into Boulevard 1 raceway channel.
- Power entry cable penetrates 8" into a panel and plugs into either a Power Distribution Housing or a BE8CPxxHJ Pass-Thru Harness.
- Use 1) In middle of run to distribute power in two directions.
2) At beginning of run where second Base Feed Harness is connected to BE8CPxxHJ and distributes power underneath Power Distribution Housing to pick-up second circuit grouping in long panel run.
- Liquitite whip 72" and 144".
- Power entry box available in black only, but "Capture Strip" connector will match the post colour as standard.
- 2 1/2" clearance in depth and 5 1/2" away from any obstructions required from power entry point.
- Comes with 32" harness attached.
- Must be hard wired to power source by a licensed electrician.

PRODUCT CODE	PRICE	SIZE/ INCHES			WEIGHT VOL	
		H	L	D	LBS	FT ³
BE81BF722	737	6	107	3	6.98	2
BE81BF1442	983	6	179	3	6.98	2

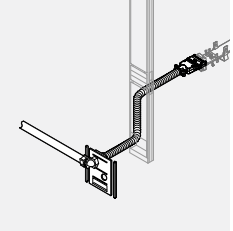
BE81BF601 • Base Feed - Single (Boulevard 1 only)

- Provides single power entry from floor, through 6" panel and into Boulevard 1 raceway panel.
- Power entry cable penetrates 8" into a panel and plugs into either a Power Distribution Housing or a BE8CPxxHJ Pass-Thru Harness.
- For 6" Power/Cable Access Panel only.
- Comes with 32" harness attached.
- Liquitite whip 72".
- Must be hard wired to power source by a licensed electrician.

PRODUCT CODE	PRICE	SIZE/ INCHES			WEIGHT VOL	
		H	L	D	LBS	FT ³
BE81BF601	380	6	107	3	4.90	0.062

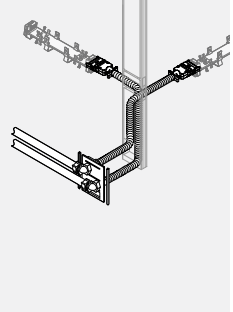
BE81BF602 • Base Feed - Double (Boulevard 1 only)

- Provides dual power entry from floor, through 6" panel and into Boulevard 1 raceway panel.
- Power entry cable penetrates 8" into a panel and plugs into either a Power Distribution Housing or a BE8CPxxHJ Pass-Thru Harness.
- Use 1. In middle of run to distribute power in two directions.
2. At beginning of run where second Base Feed Harness is connected to BE8CPxxHJ and distributes power underneath Power Distribution Housing to pick-up second circuit grouping in long panel run.
- For 6" Power/Cable Access Panel only.
- Comes with 2x32" harness attached.
- Liquitite whip 72".
- Must be hard wired to power source by a licensed electrician.

PRODUCT CODE	PRICE	SIZE/ INCHES			WEIGHT VOL	
		H	L	D	LBS	FT ³
BE81BF602	761	6	107	3	5.30	0.071

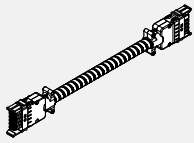
BE8JC • Jumper Cable

- **Electrically connects two Power Distribution Housings.**
- The BE8JC16 electrically connects two powered panels positioned side by side.
- The BE8JC20 electrically connects two powered panels separated by a post.
- Wires are concealed in a flexible metal conduit.
- Cannot go through a Boulevard 1 post in a corner application. (Please use the Jumper Cable Mesh)

PRODUCT CODE	PRICE	SIZE/ H	INCHES			WEIGHT VOL	
			L	D	LBS	FT ³	
BE8JC16	160	2	16.75	0.5	0.66	1.17	
BE8JC20	162	2	20.75	0.5	0.78	1.17	

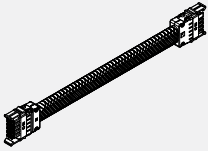
BE8JM19 • Jumper Cable Mesh

- **Electrically connects two Power Distribution Housings in Boulevard 1 panels that are separated by a post in a corner application.**
- BE8JM19 - Wires are covered with a durable nylon mesh.
- BE8JMS19 - Wires are concealed in a flexible metal shroud and covered with a durable nylon mesh.
- Used in System 3 Panels at tile position passing through post at corner application.

PRODUCT CODE	PRICE	SIZE/ H	INCHES			WEIGHT VOL	
			L	D	LBS	FT ³	
BE8JM19	162	2	19	0.5	0.75	1.17	
BE8JMS19	184	2	19	0.5	0.75	1.17	

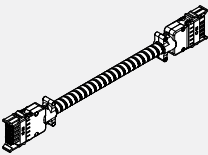
BE83BT • Base-to-Tile Cable

- **Electrically connects a Base Raceway Power Distribution Housing to a Face Mount Tile Power Distribution Housing within a System 3 PV panel.**
- Wires are concealed in a flexible metal conduit.
- BE83BT82 to be used on panels manufactured before November 1st, 2014 and BE83BT40 after.

PRODUCT CODE	PRICE	SIZE/ H	INCHES			WEIGHT VOL	
			L	D	LBS	FT ³	
BE83BT82	191	2	82.5	0.5	3.05	1.38	
BE83BT40	161	2	40.5	0.5	1.44	1.17	

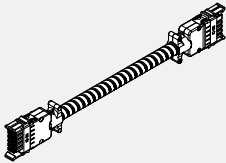
BE8CP-HH • Housing-to-Housing Pass-Thru Cable

- **Electrically connects two Power Distribution Housings in panels separated by one or more non-powered panels.**
- Wires are concealed in a flexible metal conduit.
- **NOTE:** In Boulevard 1 and or System 3 tile position applications, the Housing-to-Housing Pass-Thru Cables can only be used in a straight run.

PRODUCT CODE	PRICE	SIZE/ H	INCHES			WEIGHT VOL	
			L	D	LBS	FT ³	
BE8CP40HH	161	2	40.5	0.5	1.44	1.17	
BE8CP46HH	167	2	46.5	0.5	1.71	1.17	
BE8CP52HH	177	2	52.5	0.5	1.95	1.17	
BE8CP58HH	184	2	58.5	0.5	2.21	1.17	
BE8CP64HH	190	2	64.5	0.5	2.37	1.17	
BE8CP70HH	196	2	70.5	0.5	2.6	1.17	
BE8CP76HH	204	2	76.5	0.5	2.81	1.17	
BE8CP82HH	213	2	82.5	0.5	3.03	1.17	
BE8CP88HH	221	2	88.5	0.5	3.05	1.17	
BE8CP94HH	226	2	94.5	0.5	3.30	1.17	
BE8CP100HH	233	2	100.5	0.5	3.47	1.17	
BE8CP106HH	242	2	106.5	0.5	3.87	1.17	
BE8CP118HH	256	2	118.5	0.5	4.08	1.17	
BE8CP130HH	268	2	130.5	0.5	4.73	1.17	
BE8CP142HH	282	2	142.5	0.5	4.99	1.17	

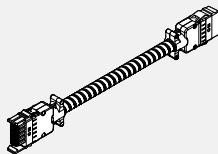
BE8CP-HJ • Housing-to-Jumper Pass-Thru Cable

- **Electrically connects a Power Distribution Housing to a Housing connection of a harness.**
- Wires are concealed in a flexible metal conduit.
- **NOTE:** In both Boulevard 1 and System 3 Tile Position applications, the Housing-to-Jumper Pass-Thru Cables can only be used in a straight run.

PRODUCT CODE	PRICE	SIZE/ H	INCHES			WEIGHT VOL	
			L	D	LBS	FT ³	
BE8CP24HJ	144	2	24	0.5	0.9	1.17	
BE8CP30HJ	151	2	30	0.5	1.3	1.17	
BE8CP36HJ	156	2	36	0.5	1.44	1.17	
BE8CP42HJ	169	2	42	0.5	1.71	1.17	
BE8CP48HJ	177	2	48	0.5	1.95	1.17	
BE8CP54HJ	188	2	54	0.5	2.21	1.17	
BE8CP60HJ	196	2	60	0.5	2.37	1.17	
BE8CP72HJ	204	2	72	0.5	2.81	1.17	
BE8CP84HJ	220	2	84	0.5	3.05	1.17	
BE8CP96HJ	233	2	96	0.5	3.3	1.17	
BE8CP108HJ	243	2	108	0.5	3.87	1.17	
BE8CP120HJ	257	2	120	0.5	4.08	1.17	
BE8CP144HJ	293	2	144	0.5	4.59	1.17	

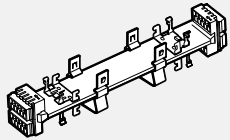
BE81D • Power Distribution Housing Kit - Concealed Desk Height (Boulevard 1 only)

- Provides two duplex receptacles per panel for all panel widths above 24" wide.
- Power Distribution Housing is specified per panel size. eg. BE81D36 is for use with a 36" panel.

PRODUCT CODE	PRICE	SIZE/ H	INCHES		WEIGHT VOL	
			L	D	LBS	FT ³
BE81D24	198	2	9.25	2.61	0.83	1.17
BE81D30	208	2	15.25	2.61	1.28	1.17
BE81D36	220	2	21.25	2.61	1.62	1.65
BE81D42	226	2	27.25	2.61	2.00	2.00
BE81D48	238	2	33.25	2.61	2.32	2.54
BE81D54	242	2	39.25	2.61	2.66	3.20
BE81D60	243	2	45.25	2.61	3.04	3.20
BE81D66	310	2	51.25	2.61	3.49	3.25
BE81D72	341	2	57.2	2.61	3.76	3.30

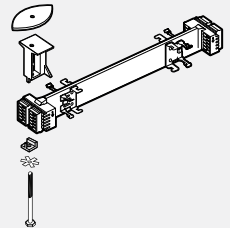
BE8U2D • Power Distribution Housing Kit - Face Mount Desk Height (Boulevard 1 only)

- Provides two duplex receptacles per panel side for all panel widths above 24" wide.
- Power Distribution Housing is specified per panel size. eg. BE8U2D36 is for use with a 36" panel.
- 24" wide panel allows for only one (1) duplex receptacle per panel side.

PRODUCT CODE	PRICE	SIZE/ H	INCHES		WEIGHT VOL	
			L	D	LBS	FT ³
BE8U2D24	198	2	9.25	2.61	0.83	1.17
BE8U2D30	208	2	15.25	2.61	1.28	1.17
BE8U2D36	220	2	21.25	2.61	1.62	1.65
BE8U2D42	226	2	27.25	2.61	2.00	2.00
BE8U2D48	238	2	33.25	2.61	2.32	2.54
BE8U2D54	242	2	39.25	2.61	2.66	3.20
BE8U2D60	243	2	45.25	2.61	3.04	3.20
BE8U2D66	310	2	51.25	2.61	3.49	3.25
BE8U2D72	341	2	57.25	2.61	3.76	3.30

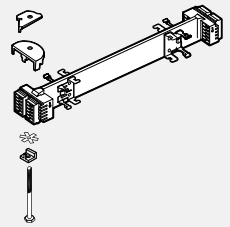
BE83D • Power Distribution Housing Kit - Base Raceway (Boulevard System 3 only)

- Provides two duplex receptacles per panel side for all panel widths above 24" wide.
- Power Distribution Housing is specified per panel size. eg. BE83D36 is for use with a 36" panel.
- 24" wide panel allows for only one (1) duplex receptacle per panel side.

PRODUCT CODE	PRICE	SIZE/ H	INCHES		WEIGHT VOL	
			L	D	LBS	FT ³
BE83D24	198	2	9.25	2.61	0.83	1.17
BE83D30	208	2	15.25	2.61	1.28	1.17
BE83D36	220	2	21.25	2.61	1.62	1.65
BE83D42	226	2	27.25	2.61	2.00	2.00
BE83D48	238	2	33.25	2.61	2.32	2.54
BE83D54	242	2	39.25	2.61	2.66	3.20
BE83D60	243	2	45.25	2.61	3.04	3.20
BE83D66	310	2	51.25	2.61	3.49	3.25
BE83D72	341	2	57.25	2.61	3.76	3.30

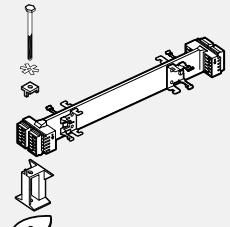
BE8U3FM • Power Distribution Housing Kit - Face Mount Tile (Boulevard System 3 only)

- Provides two duplex receptacles for all tile widths above 24". 24" wide tile allows for one (1) duplex receptacle.
- Housing and mounting hardware included.
- Specify duplexes, cables and tiles separately.
- BE83BT40 Base-to-Tile Cable is used to connect the tile mounted housing to the Power Distribution Housing tile in the base of the same "PV" panel.
- 24" wide tiles have one duplex and one data/comm opening. 30" and wider tiles have two data/comm openings.
- Note: Not compatible with panels built prior November 1st, 2014.

PRODUCT CODE	PRICE	SIZE/ H	INCHES		WEIGHT VOL	
			L	D	LBS	FT ³
BE8U3FM24	198	2	9.25	2.61	0.83	1.17
BE8U3FM30	208	2	15.25	2.61	1.28	1.17
BE8U3FM36	220	2	21.25	2.61	1.62	1.65
BE8U3FM42	226	2	27.25	2.61	2.00	2.00
BE8U3FM48	238	2	33.25	2.61	2.32	2.54
BE8U3FM54	242	2	39.25	2.61	2.66	3.20
BE8U3FM60	243	2	45.25	2.61	3.04	3.20
BE8U3FM66	310	2	51.25	2.61	3.49	3.25
BE8U3FM72	341	2	57.25	2.61	3.76	3.30

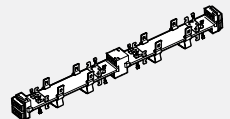
BE81D-CM • Centermount Power Distribution Housing Quad Kit - Concealed Desk Height (B1 only)

- Provides four duplex receptacles per panel for widths 36" and above.
- Centermount Distribution Housing is specified per panel size. ie. BE81D36CM is for 36" panel.
- Not available for panels less than 36" wide.

PRODUCT CODE	PRICE	SIZE/ H	INCHES		WEIGHT VOL	
			L	D	LBS	FT ³
BE81D36CM	363	2	21.99	2.61	3.24	1.65
BE81D42CM	374	2	27.99	2.61	4.00	2.00
BE81D48CM	382	2	33.99	2.61	4.64	2.54
BE81D54CM	389	2	39.99	2.61	5.32	3.20
BE81D60CM	396	2	45.99	2.61	6.04	3.20
BE81D66CM	462	2	51.99	2.61	6.98	3.25
BE81D72CM	529	2	57.99	2.61	7.52	3.30

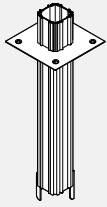
BEPE • Post Extension

- **Lightweight aluminum pole to be used to bring power and/or data/communication cables from ceiling to a panel through a post.**
- Attaches to ceiling and post.
- Includes connectors, ceiling trim plate and screws.
- Post extension will accept:
 - 75 cables 5.6mm (0.220") dia. data cables
 - 60 cables 5.6mm (0.220") dia. data cables with 1 power feed
 - 45 cables 5.6mm (0.220") dia. data cables with 2 power feeds.
- Ceiling bezel is white only.

PRODUCT CODE	PRICE	SIZE/	INCHES			WEIGHT VOL	
			L	D	LBS	FT ³	
BEPE49	124	49	2.61	2.61	5.00	0.258	
BEPE81	188	81	2.61	2.61	9.00	0.424	

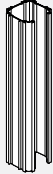
BHPOST • Lay in Post Extension

- **Three sided lightweight aluminum pole to be used to bring power and/or data/communication cables from ceiling to a panel. True lay-in application use**
- Attaches to ceiling and post.
- Includes connectors and ceiling bezel plate and screws.
- Requires vertical end trim to enclose when used in 2 way and 3 way panel run application.
- Trim encloses lay-in cable post extension, sold separately.

PRODUCT CODE	PRICE	TYPE	SIZE/	INCHES			WEIGHT VOL	
				H	L	D	LBS	FT ³
BHPOST66	195	BASE	66	2.61	2.61	8	0.346	
BHPOSTE30	91	EXTENSION	30	2.61	2.61	5	0.195	
BHPOSTE78	237	EXTENSION	78	2.61	2.61	9	0.430	

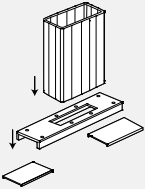
BE2PE • Off-Module Post Extension

- **An alternative to the existing Ceiling Post, allows for an off-module Ceiling Feed location.**
- Attaches to the top of horizontal trim.
- Panel ceiling post consists of two aluminum extrusions for a true lay-in application.
- Includes brackets, hardware and ceiling trim plate and screws.
- Harness length will vary in length depending on post location along the panel.
- Can only be used with Boulevard System 3 "PV" and "MV" Panels.
- Requires on site cutting of top trim for placement along panel.

PRODUCT CODE	PRICE	SIZE/	INCHES			WEIGHT VOL	
			H	L	D	LBS	FT ³
BE2PE49	281	49	7.61	3.00	5	0.258	
BE2PE81	415	81	7.61	3.00	9	0.424	

Worksurfaces

Global Contract offers a wide variety of worksurfaces and user friendly worksurface shapes to support a variety of tasks, applications and personal preferences.

- 1 1/16" particle board.
- 45 lb. density
- 100% recycled from post consumer industrial material
- "Scoops" for cable management.
- All worksurfaces have threaded inserts for metal-to-metal connection of support hardware.

- High and Low pressure worksurfaces are 3mm edge banded.
- Wood veneer surfaces or solid wood edges available.

Technical Information

Worksurfaces

- All worksurfaces have threaded inserts for metal-to-metal connection of support hardware.
- Back edge features scoop detail.
- Worksurfaces 48" or less have one scoop while those that are 54" or more have a double scoop feature with a 1/2" wire passage trough between the scoops.
- LP and HP worksurfaces are 3mm edge banded.
- LP worksurfaces are 1" thick particle board with laminate finish.
- HP worksurfaces are 1 1/16" thick particle board with laminate finish.
- T worksurfaces are 1 1/16" thick particle board with laminate finish and wood trim.
- W worksurfaces are 1 3/16" thick particle board with wood veneer finish. Edge is solid wood edge banded.
- One universal cantilever supports two abutting worksurfaces.

- 20" deep worksurfaces available at same price as 24" deep worksurfaces.
- Support hardware must be ordered separately.
- Edge banded worksurfaces without scoops available, substitute "NFL" for "SCP" at the end of the code.

Transaction Worksurfaces

- To install transaction worksurfaces to a 42" high panel, use BHBT02 bracket.
- To install transaction worksurfaces to a 37" high panel, use BHBT37 bracket.

WORKSURFACE COMPONENTS - GUIDELINES FOR ORDERING PRODUCT

Codes

The price list uses a numbering system with meaningful alphanumeric characters to create a simple-to-understand product number. This makes specifying the product much easier and more accurate.

Example of Worksurface: **BWS2460PHPMR71TCHR**

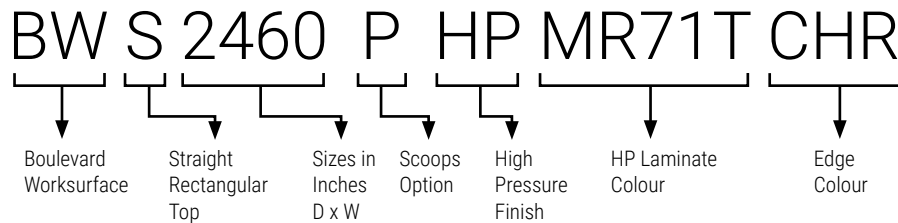

How to Specify

- Specify Boulevard worksurface type and size by code.
- Specify scoops option by adding "P" at end of code.
- Specify type of finish.
- Specify High Pressure Laminate Colour.
- Specify PVC edge colour.

Example of Hardware: **BHC24 CHR**

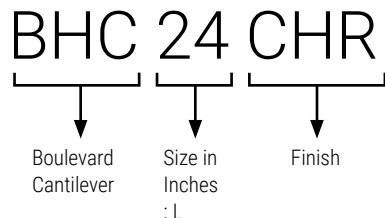

How to Specify

- Specify Boulevard hardware type and size by code.
- Specify type of finish.

BWS • Straight Rectangular Worksurface

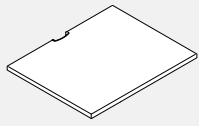

Worksurfaces 54" or Less

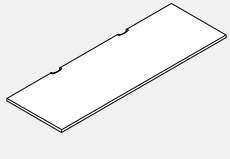

Worksurfaces 60" or Longer

- Straight rectangular worksurfaces are non-handed and can be interchanged on site.
- Please choose from DWT - Designer White, SIL - Silver or BLK - Black for scoop covers.
- Surfaces with wood trim (T) and complete wood (W) will not have the plastic scoop, they will remain with the curve cut scoop.
- To specify wood trim (T) or complete wood (W) surfaces, please remove the last "P" from the code, replace with "SCP" and add either a "T" or "W" and the old scoop style is going to be created.

PRODUCT CODE	PRICE		GROUP			SIZE / INCHES			WEIGHT	VOL
	LP*	HP*	T*	W*	H	W	D	LBS	FT ³	
BWS1818P	127	161	377	494	1	18	18	9	0.29	
BWS1824P	131	174	384	584	1	24	18	12	0.39	
BWS1830P	138	183	413	683	1	30	18	15	0.49	
BWS1836P	159	210	450	780	1	36	18	18	0.59	
BWS1842P	208	278	532	913	1	42	18	21	0.68	
BWS1848P	249	328	540	952	1	48	18	24	0.78	
BWS1854P	293	385	773	1096	1	54	18	27	0.88	
BWS1860P	329	422	780	1115	1	60	18	30	1.00	
BWS1866P	344	452	803	1145	1	66	18	32	1.10	
BWS1872P	363	478	828	1173	1	72	18	35	1.20	
BWS1878P	380	503	999	1250	1	78	18	38	1.30	
BWS1884P	417	546	1026	1325	1	84	18	41	1.40	
BWS2418P	131	168	410	549	1	18	24	12	0.40	
BWS2424P	133	178	419	652	1	24	24	16	0.52	
BWS2430P	145	190	448	768	1	30	24	20	0.65	
BWS2436P	161	213	483	875	1	36	24	23	0.78	
BWS2442P	211	280	565	1030	1	42	24	28	0.90	
BWS2448P	252	339	575	1129	1	48	24	31	1.03	
BWS2454P	299	394	803	1282	1	54	24	35	1.20	
BWS2460P	336	443	809	1313	1	60	24	39	1.30	
BWS2466P	350	462	819	1352	1	66	24	43	1.41	
BWS2472P	366	484	852	1391	1	72	24	47	1.54	
BWS2478P	392	516	922	1486	1	78	24	51	1.70	
BWS2484P	422	553	1023	1584	1	84	24	55	1.80	
BWS3018P	149	192	442	655	1	18	30	15	0.50	
BWS3024P	159	208	450	788	1	24	30	20	0.70	
BWS3030P	170	225	518	911	1	30	30	25	0.97	
BWS3036P	200	264	563	1055	1	36	30	30	1.06	
BWS3042P	283	373	668	1101	1	42	30	34	1.12	
BWS3048P	299	394	679	1176	1	48	30	39	1.30	
BWS3054P	327	420	873	1342	1	54	30	44	1.44	
BWS3060P	350	462	878	1381	1	60	30	49	1.60	
BWS3066P	364	483	908	1472	1	66	30	54	1.80	
BWS3072P	385	510	957	1560	1	72	30	59	2.00	
BWS3078P	410	540	1039	1669	1	78	30	64	2.10	
BWS3084P	456	596	1101	1780	1	84	30	69	2.24	
BWS3672P	544	714	1158	1855	1	72	36	71	2.30	

BWSP • Straight Rectangular Worksurface to span a Post

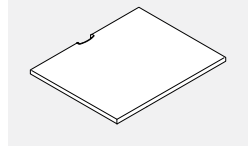

Worksurfaces 57" or Less

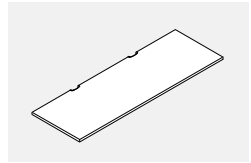

Worksurfaces 63" or Longer

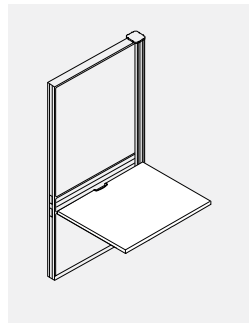

Application of Worksurface

- Straight rectangular worksurfaces are non-handed and can be interchanged on site.
- Worksurface will span the width of a post eliminating a gap between standard sizes.
- Please choose from DWT - Designer White, SIL - Silver or BLK - Black for scoop covers.
- Surfaces with wood trim (T) and complete wood (W) will not have the plastic scoop, they will remain with the curve cut scoop.
- To specify wood trim (T) or complete wood (W) surfaces, please remove the last "P" from the code, replace with "SCP" and add either a "T" or "W" and the old scoop style is going to be created.

PRODUCT CODE	PRICE LP*	GROUP HP*	T*	W*	SIZE / INCHES			WEIGHT LBS	VOL FT ³
					H	W	D		
BWSP1821P	131	174	384	584	1	21	18	10	0.34
BWSP1827P	138	183	413	683	1	27	18	13	0.44
BWSP1833P	159	210	450	780	1	33	18	16	0.53
BWSP1839P	208	278	532	913	1	39	18	19	0.63
BWSP1845P	249	328	540	952	1	45	18	22	0.72
BWSP1851P	293	385	647	972	1	51	18	25	0.82
BWSP1857P	329	422	780	1115	1	57	18	28	0.92
BWSP1863P	344	452	803	1145	1	63	18	31	1.01
BWSP1869P	363	478	828	1173	1	69	18	34	1.11
BWSP1875P	380	503	897	1250	1	75	18	37	1.21
BWSP1881P	417	546	946	1325	1	81	18	40	1.30
BWSP1887P	448	590	996	1405	1	87	18	43	1.40
BWSP2421P	133	178	419	652	1	21	24	14	0.45
BWSP2427P	145	190	448	768	1	27	24	17	0.60
BWSP2433P	161	213	483	875	1	33	24	21	0.70
BWSP2439P	211	280	565	1030	1	39	24	25	0.83
BWSP2445P	252	339	575	1129	1	45	24	29	1.00
BWSP2451P	299	394	678	1158	1	51	24	33	1.10
BWSP2457P	336	443	809	1313	1	57	24	37	1.22
BWSP2463P	350	462	852	1352	1	63	24	41	1.34
BWSP2469P	366	484	896	1391	1	69	24	45	1.47
BWSP2475P	392	516	922	1486	1	75	24	49	1.60
BWSP2481P	422	553	974	1584	1	81	24	53	1.73
BWSP2487P	456	607	1025	1678	1	87	24	57	1.90
BWSP3021P	168	208	450	788	1	21	30	17	0.56
BWSP3027P	170	225	518	911	1	27	30	22	0.72
BWSP3033P	200	264	563	1055	1	33	30	27	0.88
BWSP3039P	283	373	668	1101	1	39	30	32	1.04
BWSP3045P	299	394	679	1176	1	45	30	37	1.20
BWSP3051P	327	420	748	1217	1	51	30	41	1.40
BWSP3057P	350	462	878	1381	1	57	30	46	1.51
BWSP3063P	364	483	908	1472	1	63	30	51	1.67
BWSP3069P	385	510	957	1560	1	69	30	56	1.83
BWSP3075P	410	540	1039	1669	1	75	30	61	2.00
BWSP3081P	456	596	1101	1780	1	81	30	66	2.20
BWSP3087P	503	665	1161	1887	1	87	30	70	2.30
BWSP3675P	557	733	1158	1855	1	75	36	73	2.40

• LP = Thermally Fused Laminate, HP = High Pressure Laminate, T= High Pressure Laminate with Wood Trim, W= Wood Veneer

BWS • Straight Rectangular Worksurface without Flex Lip or Scoops

- Straight rectangular worksurfaces are non-handed and can be interchanged on site.
- Worksurface features no scoop or flex lip.

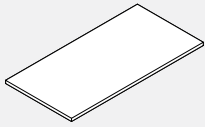

PRODUCT CODE	PRICE LP*	GROUP HP*	T*	W*	SIZE/INCHES			WEIGHT LBS	VOL FT ³
					H	W	D		
BWS1818NFL	127	161	249	367	1	18	18	9	0.28
BWS1824NFL	131	174	259	458	1	24	18	12	0.40
BWS1830NFL	138	183	289	560	1	30	18	15	0.50
BWS1836NFL	159	210	324	655	1	36	18	18	0.59
BWS1842NFL	208	278	407	788	1	42	18	21	0.68
BWS1848NFL	249	328	416	825	1	48	18	24	0.78
BWS1854NFL	293	385	522	847	1	54	18	27	0.88
BWS1860NFL	329	422	530	863	1	60	18	29	0.97
BWS1866NFL	344	452	554	906	1	66	18	32	1.10
BWS1872NFL	363	478	583	922	1	72	18	35	1.20
BWS1878NFL	380	503	647	999	1	78	18	38	1.30
BWS1884NFL	417	546	696	1077	1	84	18	41	1.40
BWS2418NFL	131	168	285	425	1	18	24	12	0.40
BWS2424NFL	133	178	291	528	1	24	24	16	0.52
BWS2430NFL	145	190	321	645	1	30	24	20	0.65
BWS2436NFL	161	213	357	751	1	36	24	24	0.78
BWS2442NFL	211	280	439	902	1	42	24	28	0.90
BWS2448NFL	252	339	449	1004	1	48	24	31	1.03
BWS2454NFL	299	394	554	1033	1	54	24	35	1.20
BWS2460NFL	336	443	561	1063	1	60	24	39	1.30
BWS2466NFL	350	462	600	1104	1	66	24	43	1.41
BWS2472NFL	366	484	645	1142	1	72	24	47	1.54
BWS2478NFL	392	516	670	1239	1	78	24	51	1.70
BWS2484NFL	422	553	722	1334	1	84	24	55	1.80
BWS3018NFL	149	192	318	530	1	18	30	15	0.50
BWS3024NFL	159	208	325	662	1	24	30	20	0.65
BWS3030NFL	170	225	392	784	1	30	30	25	0.81
BWS3036NFL	200	264	437	929	1	36	30	29	1.00
BWS3042NFL	283	373	544	975	1	42	30	34	1.13
BWS3048NFL	299	394	555	1051	1	48	30	39	1.30
BWS3054NFL	327	420	624	1092	1	54	30	44	1.44
BWS3060NFL	350	462	628	1132	1	60	30	49	1.60
BWS3066NFL	364	483	658	1221	1	66	30	54	1.76
BWS3072NFL	385	510	706	1245	1	72	30	59	1.91
BWS3078NFL	410	540	789	1420	1	78	30	64	2.10
BWS3084NFL	456	596	851	1530	1	84	30	69	2.24
BWS3672NFL	544	714	1158	1855	1	72	36	71	2.30

BWSC • Curvelinear Front Edge Worksurface

- Curvelinear front edge worksurface.
- Allows efficient use of a small footprint.
- The curve on the 30" and 36" wide worksurfaces have been modified to allow a pedestal to fit.
- Please choose from DWT - Designer White, SIL - Silver or BLK - Black for scoop covers.
- Surfaces with wood trim (T) and complete wood (W) will not have the plastic scoop, they will remain with the curve cut scoop.
- To specify wood trim (T) or complete wood (W) surfaces, please remove the last "P" from the code, replace with "SCP" and add either a "T" or "W" and the old scoop style is going to be created.
- Surfaces 60" wide will have two scoops, all others have one scoop.

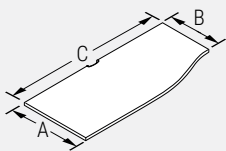

NOTE: BWSC

24	18	30
A	B	C
WIDTH	WIDTH	LENGTH

PRODUCT CODE	PRICE LP*	GROUP HP*	T*	W*	SIZE/INCHES			WEIGHT LBS	VOL FT ³
					H	W	D		
BWSC182430P	182	240	614	1010	1	30	24	18	0.65
BWSC182436P	217	289	659	1156	1	36	24	22	0.78
BWSC182442P	252	339	765	1202	1	42	24	26	0.90
BWSC182448P	289	385	775	1279	1	48	24	30	1.03
BWSC182454P	327	433	967	1445	1	54	24	34	1.20
BWSC182460P	354	483	975	1485	1	60	24	38	1.30
BWSC241830P	182	240	614	1010	1	30	24	18	0.65
BWSC241836P	217	289	659	1156	1	36	24	22	0.78
BWSC241842P	252	339	765	1202	1	42	24	26	0.90
BWSC241848P	289	385	775	1279	1	48	24	30	1.03
BWSC241854P	327	433	967	1445	1	54	24	34	1.2
BWSC241860P	354	483	975	1485	1	60	24	38	1.3
BWSC243030P	192	251	760	1272	1	30	30	23	0.81
BWSC243036P	229	289	819	1378	1	36	30	28	1
BWSC243042P	312	412	958	1629	1	42	30	33	1.13
BWSC243048P	327	433	967	1648	1	48	30	38	1.3
BWSC243054P	364	483	1184	1938	1	54	30	42	1.44
BWSC243060P	391	528	1193	1955	1	60	30	47	1.6
BWSC302430P	192	251	760	1272	1	30	30	23	0.81
BWSC302436P	229	289	819	1378	1	36	30	28	1
BWSC302442P	312	412	958	1629	1	42	30	33	1.13
BWSC302448P	327	433	967	1648	1	48	30	38	1.3
BWSC302454P	364	483	1184	1938	1	54	30	42	1.44
BWSC302460P	391	528	1193	1955	1	60	30	47	1.6

• LP = Thermally Fused Laminate, HP = High Pressure Laminate, T= High Pressure Laminate with Wood Trim, W= Wood Veneer

BWCC • Curved Corner Worksurface

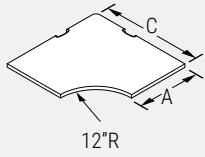

NOTE: BWCC

36 C WIDTH
18 A DEPTH

- Allows efficient use of corner space for computer or printer applications.
- BWCC3624 has a front radius of 12". It is not usable for keyboard support.
- Please choose from DWT - Designer White, SIL - Silver or BLK - Black for scoop covers.
- Surfaces with wood trim (T) and complete wood (W) will not have the plastic scoop, they will remain with the curve cut scoop.
- To specify wood trim (T) or complete wood (W) surfaces, please remove the last "P" from the code, replace with "SCP" and add either a "T" or "W" and the old scoop style is going to be created.

PRODUCT CODE	PRICE LP*	GROUP			SIZE/INCHES			WEIGHT LBS	VOL FT ³
		HP*	T*	W*	H	W	D		
BWCC3618P	397	495	875	1528	1	36	36	29	1.20
BWCC3624P	439	548	875	1528	1	36	36	32	1.20
BWCC4224P	591	736	1111	1762	1	42	42	41	1.60
BWCC4230P	607	759	1111	1762	1	42	42	45	1.60
BWCC4824P	688	857	1377	2243	1	48	48	50	2.00
BWCC4830P	688	857	1377	2243	1	48	48	56	2.00

CODE	RADIUS "R"
BWCC3618P	18"
BWCC3624P	12"
BWCC4224P	18"
BWCC4230P	12"
BWCC4824P	24"
BWCC4830P	18"

NOTE: 12" radius not recommended for keyboards

BWCF • Five Sided Corner Worksurface

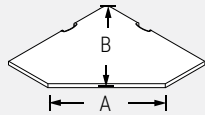

- Creates efficient use of corner space for computer or printer applications.
- Please choose from DWT - Designer White, SIL - Silver or BLK - Black for scoop covers.
- Surfaces with wood trim (T) and complete wood (W) will not have the plastic scoop, they will remain with the curve cut scoop.
- To specify wood trim (T) or complete wood (W) surfaces, please remove the last "P" from the code, replace with "SCP" and add either a "T" or "W" and the old scoop style is going to be created.

PRODUCT CODE	PRICE LP*	GROUP			SIZE/INCHES			WEIGHT LBS	VOL FT ³
		HP*	T*	W*	H	W	D		
BWCF3012P	259	320	828	1366	1	30	30	28	1.00
BWCF3612P	341	425	944	1380	1	36	36	30	1.03
BWCF3618P	341	425	844	1380	1	36	36	31	1.20
BWCF3624P	354	446	844	1380	1	36	36	33	1.20
BWCF3630P	372	465	844	1380	1	36	36	35	1.20
BWCF4218P	485	607	1064	1612	1	42	42	40	1.60
BWCF4224P	503	627	1064	1612	1	42	42	45	1.60
BWCF4230P	517	652	1064	1612	1	42	42	47	1.60
BWCF4818P	550	689	1158	1767	1	48	48	40	1.60
BWCF4824P	567	707	1158	1767	1	48	48	45	1.60
BWCF4830P	596	747	1158	1767	1	48	48	47	1.60

CODE	PANEL SIZES	ADJOINED WORKSURFACE DEPTH	A	B
BWCF3012P	30	12	25.5	29.8
BWCF3612P	36	12	34.0	34.0
BWCF3618P	36	18	25.5	37.9
BWCF3624P	36	24	17.0	42.1
BWCF3630P	36	30	8.5	46.4
BWCF4218P	42	18	33.9	42.1
BWCF4224P	42	24	25.5	46.4
BWCF4230P	42	30	17.0	50.6
BWCF4818P	48	18	42.4	46.4
BWCF4824P	48	24	33.9	50.6
BWCF4830P	48	30	25.5	54.8

BWCL • "L" Corner Worksurface

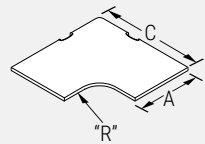

NOTE: BWCL
• 5" radius not recommended for keyboards.

36 C WIDTH
18 A DEPTH

- Creates efficient use of corner space for computer or printer applications.
- Please choose from DWT - Designer White, SIL - Silver or BLK - Black for scoop covers.
- Surfaces with wood trim (T) and complete wood (W) will not have the plastic scoop, they will remain with the curve cut scoop.
- To specify wood trim (T) or complete wood (W) surfaces, please remove the last "P" from the code, replace with "SCP" and add either a "T" or "W" and the old scoop style is going to be created.

PRODUCT CODE	PRICE LP*	GROUP			SIZE/INCHES			WEIGHT LBS	VOL FT ³
		HP*	T*	W*	H	W	D		
BWCL3018P	236	293	463	1336	1	30	30	20	0.80
BWCL3024P	241	305	463	1336	1	30	30	23	0.80
BWCL3618P	354	446	626	1342	1	36	36	27	1.20
BWCL3624P	373	465	626	1342	1	36	36	31	1.20
BWCL3630P	389	485	626	1342	1	36	36	34	1.20
BWCL4218P	518	645	861	1575	1	42	42	32	1.60
BWCL4224P	536	668	861	1575	1	42	42	39	1.60
BWCL4230P	550	689	861	1575	1	42	42	44	1.60
BWCL4818P	567	709	997	1739	1	48	48	38	2.00
BWCL4824P	581	726	997	1739	1	48	48	47	2.00
BWCL4830P	600	749	997	1739	1	48	48	54	2.00

• LP = Thermally Fused Laminate, HP = High Pressure Laminate, T= High Pressure Laminate with Wood Trim, W= Wood Veneer

BWAC45 • Curved Corner Worksurface for 45 Degree Angle

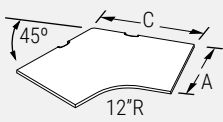

- **Five sided corner unit for 45 degree Corner Posts.**
- Creates efficient use of space for computer or printer application.
- Please choose from DWT - Designer White, SIL - Silver or BLK - Black for scoop covers.
- Surfaces with wood trim (T) and complete wood (W) will not have the plastic scoop, they will remain with the curve cut scoop.
- To specify wood trim (T) or complete wood (W) surfaces, please remove the last "P" from the code, replace with "SCP" and add either a "T" or "W" and the old scoop style is going to be created.

NOTE: BWAC

45°	24	18
	C	A
45° POST	WIDTH	DEPTH

PRODUCT CODE	PRICE LP*	GROUP HP*	T*	W*	SIZE/INCHES			WEIGHT LBS	VOL FT³
					H	W	D		
BWAC452418P	397	495	1077	1437	1	24	18	38	1.14
BWAC452424P	411	516	1624	2168	1	24	24	42	1.29
BWAC452430P	431	537	2146	2864	1	24	30	48	1.45
BWAC453018P	512	638	1309	1742	1	30	18	53	1.61
BWAC453024P	578	723	1556	2075	1	30	24	60	1.80
BWAC453030P	641	802	1991	2655	1	30	30	66	2.01
BWAC453618P	720	895	1515	2022	1	36	18	66	2.01
BWAC453624P	797	998	1868	2486	1	36	24	71	2.16
BWAC453630P	877	1094	2352	3135	1	36	30	76	2.30

BWAC60 • Curved Corner Worksurface for 60 Degree Angle

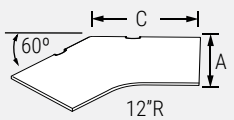

- **Five sided corner unit for 60 degree Corner Posts.**
- Creates efficient use of space for computer or printer application.
- Please choose from DWT - Designer White, SIL - Silver or BLK - Black for scoop covers.
- Surfaces with wood trim (T) and complete wood (W) will not have the plastic scoop, they will remain with the curve cut scoop.
- To specify wood trim (T) or complete wood (W) surfaces, please remove the last "P" from the code, replace with "SCP" and add either a "T" or "W" and the old scoop style is going to be created.

NOTE: BWAC

60°	24	18
	C	A
60° POST	WIDTH	DEPTH

PRODUCT CODE	PRICE LP*	GROUP HP*	T*	W*	SIZE/INCHES			WEIGHT LBS	VOL FT³
					H	W	D		
BWAC602418P	341	425	896	1192	1	24	18	33	0.99
BWAC602424P	354	446	1073	1427	1	24	24	36	1.09
BWAC602430P	372	465	1137	1517	1	24	30	39	1.19
BWAC603018P	465	581	1097	1461	1	30	18	48	1.46
BWAC603024P	508	631	1291	1725	1	30	24	52	1.58
BWAC603030P	544	683	1407	1875	1	30	30	56	1.71
BWAC603618P	661	829	1281	1706	1	36	18	66	2.01
BWAC603624P	712	892	1515	2022	1	36	24	71	2.16
BWAC603630P	762	954	1649	2200	1	36	30	76	2.31

BWCE • Extended Curved Corner Worksurface

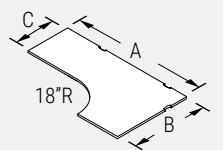

- **Extended curved corner unit with a radius user edge.**
- Creates efficient use of a corner unit.
- Please choose from DWT - Designer White, SIL - Silver or BLK - Black for scoop covers.
- Surfaces with wood trim (T) and complete wood (W) will not have the plastic scoop, they will remain with the curve cut scoop.
- To specify wood trim (T) or complete wood (W) surfaces, please remove the last "P" from the code, replace with "SCP" and add either a "T" or "W" and the old scoop style is going to be created.

NOTE: BWCE

60	42	24
A	B	C
WIDTH	WIDTH	LENGTH

PRODUCT CODE	PRICE LP*	GROUP HP*	T*	W*	SIZE/INCHES			WEIGHT LBS	VOL FT³
					H	W	D		
BWCE426024P	688	857	1316	2161	1	60	42	57	2.2
BWCE426624P	758	947	1376	2254	1	66	42	62	2.5
BWCE427224P	835	1045	1541	2527	1	72	42	66	2.7
BWCE427824P	893	1117	1647	2695	1	78	42	71	2.9
BWCE428424P	962	1201	1772	2905	1	84	42	75	3.1
BWCE486024P	786	984	1635	2682	1	60	48	66	2.5
BWCE486624P	874	1092	1685	2826	1	66	48	71	2.8
BWCE487224P	956	1197	1685	2826	1	72	48	76	3.1
BWCE487824P	1021	1273	1854	3041	1	78	48	83	3.3
BWCE488424P	1083	1352	1854	3041	1	84	48	93	3.6
BWCE486030P	874	1092	1635	2682	1	60	48	68	2.5
BWCE486630P	956	1197	1721	2825	1	66	48	74	2.8
BWCE487230P	1021	1273	1762	2887	1	72	48	80	3.1
BWCE487830P	1083	1352	1910	3131	1	78	48	85	3.3
BWCE488430P	1158	1450	2058	3369	1	84	48	96	3.6
BWCE604224P	688	857	1316	2161	1	42	60	57	2.2
BWCE604824P	786	984	1635	2682	1	48	60	66	2.6
BWCE604830P	874	1092	1635	2682	1	48	60	68	2.6
BWCE664224P	758	947	1376	2254	1	42	66	62	2.5
BWCE664824P	874	1092	1685	2826	1	48	66	71	2.8
BWCE664830P	956	1197	1721	2825	1	48	66	74	2.8
BWCE724224P	835	1045	1541	2527	1	42	72	66	2.7
BWCE724824P	956	1197	1685	2826	1	48	72	76	3.1
BWCE724830P	1021	1273	1762	2887	1	48	72	80	3.1
BWCE784224P	893	1117	1647	2695	1	42	78	71	2.9
BWCE784824P	1021	1273	1854	3041	1	48	78	83	3.3
BWCE784830P	1083	1352	1910	3131	1	48	78	85	3.3
BWCE844224P	962	1201	1772	2905	1	42	84	75	3.1
BWCE844824P	1083	1352	1854	3043	1	48	84	93	3.6
BWCE844830P	1158	1450	2058	3369	1	48	84	96	3.6

• LP = Thermally Fused Laminate, HP = High Pressure Laminate, T= High Pressure Laminate with Wood Trim, W= Wood Veneer

BWCEC • Extended Curvilinear Corner Worksurface

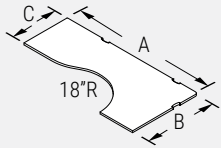

- **Extended curved corner unit with a radius user edge.**
- Creates efficient use of a corner unit.
- Please choose from DWT - Designer White, SIL - Silver or BLK - Black for scoop covers.
- Surfaces with wood trim (T) and complete wood (W) will not have the plastic scoop, they will remain with the curve cut scoop.
- To specify wood trim (T) or complete wood (W) surfaces, please remove the last "P" from the code, replace with "SCP" and add either a "T" or "W" and the old scoop style is going to be created.

NOTE: BWSC

66	42	24
A	B	C
WIDTH	WIDTH	LENGTH

PRODUCT CODE	PRICE LP*	GROUP HP*	T*	W*	SIZE/INCHES			WEIGHT LBS	VOL FT ³
					A	B	C		
BWCEC366024P	645	805	1631	2172	36	60	24	59	0.05
BWCEC366624P	678	846	1692	2254	36	66	24	65	0.60
BWCEC367224P	737	922	1868	2486	36	72	24	71	0.07
BWCEC367824P	801	1000	1976	2633	36	78	24	77	0.07
BWCEC368424P	894	1117	2174	2810	36	84	24	83	0.08
BWCEC426624P	780	973	1972	2629	42	66	24	76	0.07
BWCEC427224P	863	1078	2174	2900	42	72	24	83	0.08
BWCEC427824P	920	1152	2306	3073	42	78	24	90	0.08
BWCEC428424P	992	1238	2461	3281	42	84	24	96	0.09
BWCEC487230P	1053	1317	2402	3200	48	72	30	94	0.09
BWCEC487830P	1132	1416	2564	3415	48	78	30	102	0.09
BWCEC488430P	1196	1495	2726	3629	48	84	30	110	0.10
BWCEC488424P	1131	1416	2461	3281	48	84	24	110	0.10
BWCEC603624P	645	805	1631	2172	60	36	24	59	0.05
BWCEC663624P	678	846	1692	2254	66	36	24	65	0.60
BWCEC664224P	780	973	1972	2629	66	42	24	76	0.07
BWCEC723624P	737	922	1868	2486	72	36	24	71	0.07
BWCEC724224P	863	1078	2174	2900	72	42	24	83	0.08
BWCEC724830P	1053	1317	2402	3200	72	48	30	94	0.09
BWCEC783624P	801	1000	1976	2633	78	36	24	77	0.07
BWCEC784224P	920	1152	2306	3073	78	42	24	89	0.08
BWCEC784830P	1132	1416	2564	3415	78	48	30	102	0.09
BWCEC843624P	894	1117	2174	2810	84	36	24	83	0.08
BWCEC844224P	992	1238	2174	2810	84	42	24	96	0.09
BWCEC844824P	1131	1416	2461	3281	84	48	24	110	0.10
BWCEC844830P	1196	1495	2726	3629	84	48	30	110	0.10

BWSL • Curvilinear Arc Worksurface

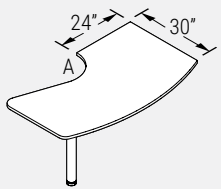

- **Arc shaped worksurface provides an extended conferencing area.**
- 1 BHML03 Monoleg included.
- Not recommended for use with modesty panel due to knee swing interference.
- For chrome finish on leg, please add \$109 list upcharge.

RIGHT HAND SHOWN MONO-LEG MOUNTED ON THE RIGHT USER SIDE.

PRODUCT CODE	PRICE LP*	GROUP HP*	T*	W*	SIZE/INCHES			WEIGHT LBS	VOL FT ³
					H	W	D		
BWSL3060L	893	1062	1214	2063	29	60	30	48	1.69
BWSL3066L	935	1112	1349	2311	29	66	30	53	1.85
BWSL3072L	972	1165	1485	2564	29	72	30	58	2.01
BWSL3060R	893	1062	1214	2063	29	60	30	48	1.69
BWSL3066R	935	1112	1349	2311	29	66	30	53	1.85
BWSL3072R	972	1165	1485	2564	29	72	30	58	2.01

- A = 27" for 60", 66" worksurfaces
- A = 26.5" for 72" worksurfaces

BWSL • Curvilinear Arc Worksurface

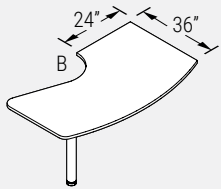

- **Arc shaped worksurface provides an extended conferencing area.**
- 1 BHML03 Monoleg included.
- For chrome finish on leg, please add \$109 list upcharge.

RIGHT HAND SHOWN MONO-LEG MOUNTED ON THE RIGHT USER SIDE.

PRODUCT CODE	PRICE LP*	GROUP HP*	T*	W*	SIZE/INCHES			WEIGHT LBS	VOL FT ³
					H	W	D		
BWSL3660L	1012	1212	1380	2375	29	60	36	57	2.07
BWSL3666L	1095	1317	1541	2663	29	66	36	64	2.26
BWSL3672L	1174	1416	1698	2955	29	72	36	71	2.45
BWSL3660R	1012	1212	1380	2375	29	60	36	57	2.07
BWSL3666R	1095	1317	1541	2663	29	66	36	64	2.26
BWSL3672R	1174	1416	1698	2955	29	72	36	71	2.45

- B = 33" for 60", 66" worksurfaces
- B = 32.5" for 72" worksurfaces

• LP = Thermally Fused Laminate, HP = High Pressure Laminate, T= High Pressure Laminate with Wood Trim, W= Wood Veneer

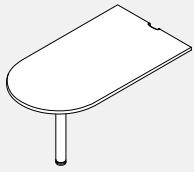
BWD • "D" Worksurface

- **Rounded worksurface for conferencing.**
- Supported by Monoleg at one end and panel at the opposite end.
- 1 BHML03 Monoleg included.
- Modesty panel available, see BWMP (not included).
- For chrome finish on leg, please add \$109 list upcharge.
- Please choose from DWT - Designer White, SIL - Silver or BLK - Black for scoop covers.
- Surfaces with wood trim (T) and complete wood (W) will not have the plastic scoop, they will remain with the curve cut scoop.
- To specify wood trim (T) or complete wood (W) surfaces, please remove the last "P" from the code, replace with "SCP" and add either a "T" or "W" and the old scoop style is going to be created.

PRODUCT CODE	PRICE LP*	GROUP			SIZE/INCHES			WEIGHT LBS	VOL FT ³
		HP*	T*	W*	H	W	D		
BWD2442P	569	659	722	1243	1	42	24	27	0.97
BWD2448P	593	693	754	1285	1	48	24	31	1.11
BWD2454P	610	712	832	1530	1	54	24	35	1.24
BWD2460P	623	725	870	1774	1	60	24	39	1.36
BWD2466P	641	754	908	1840	1	66	24	43	1.52
BWD2472P	661	779	946	1933	1	72	24	47	1.66
BWD3048P	596	695	863	1766	1	48	30	38	1.38
BWD3054P	627	733	897	1826	1	54	30	43	1.56
BWD3060P	665	780	941	1941	1	60	30	48	1.69
BWD3066P	694	817	1010	2036	1	66	30	53	1.82
BWD3072P	731	864	1034	2135	1	72	30	58	2.01
BWD3078P	774	917	1103	2295	1	78	30	63	2.25
BWD3084P	840	999	1173	2457	1	84	30	68	2.42

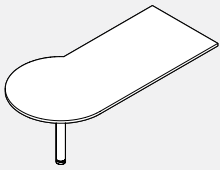
BWP • "P" Worksurface

- **Rounded worksurface provides an extended conferencing area.**
- **36" diameter end.**
- Supported by monoleg at one end and panel at the opposite end.
- 1 BHML03 Monoleg included.
- Modesty panel available, see BWMP (not included).
- For chrome finish on leg, please add \$109 list upcharge.

PRODUCT CODE	PRICE LP*	GROUP			SIZE/INCHES			WEIGHT LBS	VOL FT ³
		HP*	T*	W*	H	W	D		
BWPL3054	877	1038	1203	2567	1	54	36	51	1.87
BWPL3060	916	1088	1214	2593	1	60	36	58	2.03
BWPL3066	992	1182	1245	2915	1	66	36	65	2.24
BWPL3072	1034	1236	1370	3239	1	72	36	70	2.41
BWPL3084	1143	1374	1731	3821	1	84	36	81	2.79
BWPR3054	877	1038	1203	2567	1	54	36	51	1.87
BWPR3060	916	1088	1214	2593	1	60	36	58	2.03
BWPR3066	992	1182	1245	2915	1	66	36	65	2.24
BWPR3072	1034	1236	1370	3239	1	72	36	70	2.41
BWPR3084	1143	1374	1731	3821	1	84	36	81	2.79

LEFT HAND SHOWN

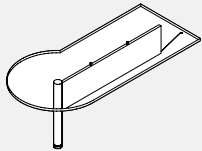
BWMP • "D" and "P" Worksurface Modesty Panel

- **Made of cold rolled steel, fastens to the worksurface and Monoleg for additional privacy.**

PRODUCT CODE	PRICE	SIZE/INCHES			WEIGHT LBS	VOL FT ³
		H	W	D		
BWMP1248	126	1	32	12	12	0.4
BWMP1254	149	1	38	12	15	0.47
BWMP1260	174	1	44	12	17	0.53
BWMP1266	200	1	50	12	20	0.61
BWMP1272	225	1	56	12	22	0.66
BWMP1278	240	1	62	12	25	0.71
BWMP1284	260	1	68	12	27	0.79

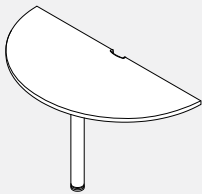
BWR • Radius Worksurface

- **Rounded worksurface for conferencing provides a radius corner.**
- 18" and 24" come with 1 BHML03 Monoleg and 30" comes with 2.
- Radius cut out on the straight edge allows space for aluminum trims.
- For chrome finish on leg, please add \$109 list upcharge for each leg.
- Please choose from DWT - Designer White, SIL - Silver or BLK - Black for scoop covers.
- Surfaces with wood trim (T) and complete wood (W) will not have the plastic scoop, they will remain with the curve cut scoop.
- To specify wood trim (T) or complete wood (W) surfaces, please remove the last "P" from the code and add either a "T" or "W" and the old scoop style is going to be created.

PRODUCT CODE	PRICE LP*	GROUP			SIZE/INCHES			WEIGHT LBS	VOL FT ³
		HP*	T*	W*	H	W	D		
BWR18P	503	578	819	1379	1	38.5	18	27	1.70
BWR24P	577	668	896	1631	1	50.5	24	41	2.20
BWR30P	969	1108	1339	2466	1	62.5	30	59	2.70

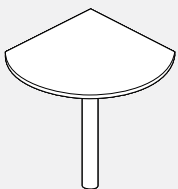
BWRTD • Teardrop Worksurface

- **Rounded worksurface for conferencing provides a radius corner from a worksurface to worksurface.**
- 1 BHML03 Monoleg included.
- For chrome finish on leg, please add \$109 list upcharge.

PRODUCT CODE	PRICE LP*	GROUP			SIZE/INCHES			WEIGHT LBS	VOL FT ³
		HP*	T*	W*	H	W	D		
BWRTD18	324	369	677	831	1	18	18	24	1.60
BWRTD24	391	443	804	1004	1	24	24	33	1.90
BWRTD30	469	569	973	1235	1	30	30	43	2.20

• LP = Thermally Fused Laminate, HP = High Pressure Laminate, T = High Pressure Laminate with Wood Trim, W = Wood Veneer

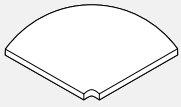
BWRP • Corner Radius Worksurface with Cutout

- **Corner Radius Worksurface with Cut-Out allows worksurface to be used around a post.**
- Cut out fits snug to the post, if trim is attached to the post, the worksurface or PVC trim may need to be cut on site to fit.

PRODUCT CODE	PRICE LP*	GROUP			SIZE/INCHES			WEIGHT LBS	VOL FT ³
		HP*	T*	W*	H	W	D		
BWRP1818	162	202	400	554	1	21	21	12	0.40
BWRP2424	235	293	533	815	1	27	27	19	0.64
BWRP3030	289	364	666	919	1	33	33	29	1.00

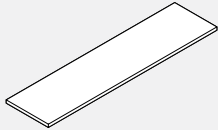
BWT • Transaction Worksurface

- **Attaches to the top of a 37" or 42" high panel to form a transaction worksurface.**
- To attach a Boulevard 1 37" high panel please specify BHBT37, all other heights specify BHBT02.
- To attach a Boulevard 1 panel with flat trim, please specify BHBT37FT or BHBT02FT.

PRODUCT CODE	PRICE LP*	GROUP			SIZE/INCHES			WEIGHT LBS	VOL FT ³
		HP*	T*	W*	H	W	D		
BWT1512	60	77	162	235	1	12	15	5	0.22
BWT1518	74	102	202	269	1	18	15	7	0.30
BWT1524	93	124	245	355	1	24	15	10	0.38
BWT1530	112	146	287	422	1	30	15	12	0.46
BWT1536	128	170	330	459	1	36	15	14	0.54
BWT1542	146	194	380	532	1	42	15	17	0.62
BWT1548	166	217	403	575	1	48	15	19	0.70
BWT1554	178	239	455	601	1	54	15	22	0.78
BWT1560	199	263	472	630	1	60	15	24	0.86
BWT1566	213	284	515	692	1	66	15	28	0.94
BWT1572	234	307	556	727	1	72	15	29	1.02
BWT1578	249	333	600	938	1	78	15	31	1.10
BWT1584	267	353	714	1021	1	84	15	34	1.18

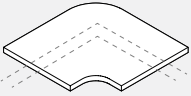
BWTC • Transaction Corner Worksurface

- **Attaches to the top of a 37" or 42" high panel to form a corner transaction worksurface.**
- Covers 12" of a panel.
- To attach a 37" high panel please specify BHBT37, all other heights specify BHBT02.
- To attach a Boulevard 1 panel with flat trim, please specify BHBT37FT or BHBT02FT.

PRODUCT CODE	PRICE LP*	GROUP			SIZE/INCHES			WEIGHT LBS	VOL FT ³
		HP*	T*	W*	H	W	D		
BWTC90	159	199	332	714	1	20.7	20.7	11	0.49
BWTC45	195	241	387	742	1	21.5	21.5	12	0.53
BWTC60	204	241	387	742	1	22.5	22.5	14	0.60

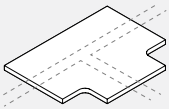
BWTT • Transaction "T" Worksurface

- **Attaches to the top of a 37" or 42" high panel to form a "T" corner transaction worksurface**
- Covers 12" of a panel.
- To attach a 37" high panel please specify BHBT37, all other heights specify BHBT02.

PRODUCT CODE	PRICE LP*	GROUP			SIZE/INCHES			WEIGHT LBS	VOL FT ³
		HP*	T*	W*	H	W	D		
BWTT2721	171	212	349	893	1	21.5	26.5	15	0.6

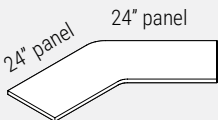
BWTAC • Transaction Worksurface for 45 Degree Corner Worksurface

- **Attaches to the top of 37" or 42" high panel to form a 45 degree corner transaction worksurface.**
- To attach a 37" high panel please specify BHBT37, all other heights specify BHBT02.

PRODUCT CODE	PRICE LP*	GROUP			SIZE/INCHES			WEIGHT LBS	VOL FT ³
		HP*	T*	W*	H	W	D		
BWTAC452415	707	885	948	1294	1	47	15	39	1.38

BWTAC • Transaction Worksurface for 60 Degree Corner Worksurface

- **Attaches to the top of 42" high panel to form a 60 degree corner transaction worksurface.**
- To attach a 37" high panel please specify BHBT37, all other heights specify BHBT02.

PRODUCT CODE	PRICE LP*	GROUP			SIZE/INCHES			WEIGHT LBS	VOL FT ³
		HP*	T*	W*	H	W	D		
BWTAC602415	765	958	1010	1348	1	44	15	38	1.32

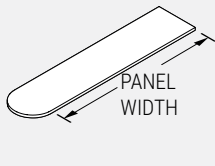
BWTD • Transaction “D” Worksurface

- Attaches to the top of a 37" or 42" high panel to form a transaction worksurface with a radiused end.
- Surface overhangs the panel by 7 1/2" on one side.
- To attach a 37" high panel please specify BHBT37, all other heights specify BHBT02.

PRODUCT CODE	PRICE LP*	GROUP HP*	T*	W*	SIZE/INCHES			WEIGHT LBS	VOL FT ³
					H	W	D		
BWTD1530	145	190	365	590	1	37.5	15	17	0.65
BWTD1536	153	204	386	626	1	43.5	15	19	0.69
BWTD1542	171	229	427	691	1	49.5	15	22	0.74
BWTD1548	192	251	448	748	1	55.5	15	25	0.77
BWTD1554	207	274	465	775	1	61.5	15	27	0.85
BWTD1560	229	303	478	796	1	67.5	15	30	0.94
BWTD1566	245	323	548	913	1	73.5	15	33	1.02
BWTD1572	265	351	615	1025	1	79.5	15	35	1.10

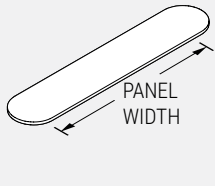
BWTDD • Transaction Double “D” Worksurface

- Attaches to the top of a 37" or 42" high panel to form a transaction worksurface with 2 radius ends.
- Surface overhangs the panel by 7 1/2" on each end.
- To attach a 37" high panel please specify BHBT37, all other heights specify BHBT02.

PRODUCT CODE	PRICE LP*	GROUP HP*	T*	W*	SIZE/ INCHES			WEIGHT LBS	VOL FT ³
					H	W	D		
BWTDD1548	213	284	548	913	1	63	15	28	1.00
BWTDD1554	234	307	564	941	1	69	15	31	1.01
BWTDD1560	249	333	579	965	1	75	15	33	1.04
BWTDD1566	271	355	649	1077	1	81	15	35	1.13
BWTDD1572	289	385	716	1192	1	87	15	38	1.21

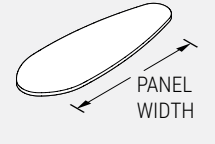
BWTE • Elliptical Transaction Worksurface

- Attaches to the top of a 37" or 42" high panel to form a transaction worksurface.
- To attach a 37" high panel please specify BHBT37, all other heights specify BHBT02.
- Depth different than standard tops.

PRODUCT CODE	PRICE LP*	GROUP HP*	T*	W*	SIZE/ INCHES			WEIGHT LBS	VOL FT ³
					H	W	D		
BWTE36	341	425	1060	1556	1	52	18	22	0.78
BWTE42	389	485	1060	1556	1	58	19	24	0.81

BWTP • Oval Transaction Worksurface

- Attaches to the top of a 37" or 42" high panel to form a transaction worksurface.
- To attach a 37" high panel please specify BHBT37, all other heights specify BHBT02.
- Must be specified at post condition or panel joint.

PRODUCT CODE	PRICE LP*	GROUP HP*	T*	W*	SIZE/ INCHES			WEIGHT LBS	VOL FT ³
					H	W	D		
BWTP1518	245	305	442	638	1	15	18	10	0.35

BWCD • Round Table

- Freestanding round meeting table with 4 prong tubular base.
- For chrome base please upcharge \$109 list.

PRODUCT CODE	PRICE LP*	GROUP HP*	T*	W*	SIZE/ INCHES			WEIGHT LBS	VOL FT ³
					H	W	D		
BWCD30	505	557	885	1150	29	30 dia	30 dia	35	10.0
BWCD36	573	641	1004	1321	29	36 dia	36 dia	42	10.0
BWCD42	701	805	1326	1788	29	42 dia	42 dia	52	11.0

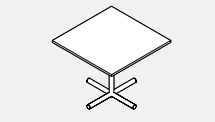
BWSQ • Square Table

- Freestanding square meeting table with 4 prong tubular base.
- For chrome base please upcharge \$109 list.

PRODUCT CODE	PRICE LP*	GROUP HP*	T*	W*	SIZE/ INCHES			WEIGHT LBS	VOL FT ³
					H	W	D		
BWSQ24	483	528	626	819	29	24	24	34	10.0
BWSQ30	505	557	766	1079	29	30	30	38	10.0
BWSQ36	573	641	893	1310	29	36	36	46	11.0
BWSQ42	701	805	1026	1708	29	42	42	57	11.0

BHCL • "C" Leg

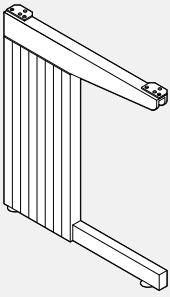

• **Attaches to panel support worksurface or to provide freestanding table support.**

- Steel structure, PVC cover.
- Universal non-handed.
- For a single rectangular freestanding worksurface application, specify two "C" Legs and one Modesty Panel of corresponding width.
- May be used as a shared leg between two adjoining worksurfaces. Specify one "C" Leg, one Modesty Panel of corresponding width, plus one Modesty Panel Extension Bracket.
- For corner worksurfaces, specify two "C" Legs, one Corner Leg and two Modesty Panels 6" shorter than rear sides of the corner worksurface.
- Can be used as a floor support in a panel attached application (similar to a cantilever).
- Includes worksurface mounting brackets with screws, Bracket Retainer Clip and panel bracket.
- Accommodates 15" knee space.
- Intended for use with flexlip worksurfaces. When used on other worksurfaces, modesty panel must be installed upside down.

PRODUCT CODE	PRICE	SIZE/ INCHES			WEIGHT VOL	
		H	W	D	LBS	FT ³
BHCL2618	227	25	1	18	7	0.27
BHCL2624	235	25	1	24	8	0.36
BHCL2918	245	28	1	18	8	0.30
BHCL2924	253	28	1	24	9	0.40

BKC • Corner Leg



• **Five sided worksurface support.**

- Steel construction.
- Non handed.
- Includes bolts for modesty panel attachment.
- For corner worksurfaces, specify two "C" Legs, one Corner Leg and two Modesty Panels 6" shorter than rear sides of the corner worksurface.

PRODUCT CODE	PRICE	SIZE/ INCHES			WEIGHT VOL	
		H	W	D	LBS	FT ³
BKC26	144	25	7	7	3.0	0.02
BKC29	162	28	7	7	3.2	0.02

BKMP • Modesty Panel

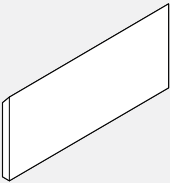

• **For rectangular worksurfaces, specify Modesty Panel of corresponding width. For corner worksurfaces, specify two Modesty Panels 6" shorter than rear side of corner worksurface.**

- Attaches between two "C" Legs, or between one "C" Leg and a Corner Leg, or a shared "C" Leg and "C" Leg at the end of a run.
- Includes brackets and screws to attach Modesty Panel to worksurface.
- For use with flex lip worksurfaces only.
- To install on "SCP" or "NFL" worksurface, modesty panel must be inverted.

PRODUCT CODE	PRICE	SIZE/ INCHES			WEIGHT VOL	
		H	W	D	LBS	FT ³
BKMP1224	170	11	24	0.25	2.75	0.17
BKMP1230	179	11	30	0.25	2.75	0.21
BKMP1236	194	11	36	0.25	3.00	0.25
BKMP1242	201	11	42	0.25	4.00	0.29
BKMP1248	212	11	48	0.25	4.50	0.33
BKMP1254	221	11	54	0.25	5.00	0.38
BKMP1260	235	11	60	0.25	5.50	0.42

BHMEB • Modesty Panel Extension Bracket



• **Modesty Panel Extension Bracket made of cold rolled steel.**

- Attaches the Modesty Panel of an adjoining worksurface to a shared "C" Leg.
- Includes all attachment hardware.

PRODUCT CODE	PRICE	SIZE/ INCHES			WEIGHT VOL	
		H	W	D	LBS	FT ³
BHMEB01	23	10	1.5	0.125	0.5	0.01

BHFG • Full Gable - Self Edged

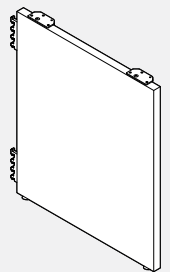

• **Provides floor standing support while enclosing an end of a run of worksurfaces.**

- Includes attachment hardware, Bracket Retainer Clip and levelling glides.
- Non-handed.
- May be used as a shared gable between two adjoining worksurfaces.

PRODUCT CODE	PRICE LP*	GROUP HP*	SIZE/ INCHES			WEIGHT VOL	
			H	W	D	LBS	FT ³
BHFG2608	156	192	25	1	8	7	0.14
BHFG2612	187	234	25	1	12	13	0.21
BHFG2618	229	284	25	1	18	13	0.27
BHFG2624	251	313	25	1	24	19	0.36
BHFG2630	339	420	25	1	30	23	0.45
BHFG2636	422	528	25	1	36	24	0.57
BHFG2908	156	192	28	1	8	7	0.16
BHFG2912	187	234	28	1	12	14	0.30
BHFG2918	229	284	28	1	18	14	0.30
BHFG2924	251	313	28	1	24	17	0.40
BHFG2930	339	420	28	1	30	21	0.50
BHFG2936	422	528	28	1	36	26	0.65

• LP = Thermally Fused Laminate, HP = High Pressure Laminate, T= High Pressure Laminate with Wood Trim, W= Wood Veneer

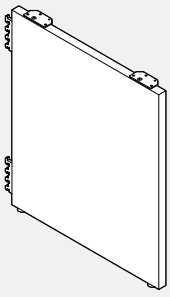
BHFGP • Full Gable - 3mm PVC Edged

- Provides floor standing support while enclosing an end of a run of worksurfaces.
- Includes attachment hardware, Bracket Retainer Clip and levelling glides.
- Provides consistent edging matching the worksurface trim.
- Handed once installed.
- May be used as a shared gable between two adjoining worksurfaces.

PRODUCT CODE	PRICE LP*	GROUP HP*	SIZE/ INCHES			WEIGHT VOL	
			H	W	D	LBS	FT ³
BHFGP2608	146	182	25	1	8	7	0.14
BHFGP2612	187	234	25	1	12	13	0.21
BHFGP2618	229	284	25	1	18	13	0.27
BHFGP2624	251	313	25	1	24	19	0.36
BHFGP2630	339	420	25	1	30	23	0.45
BHFGP2636	422	528	25	1	36	24	0.57
BHFGP2908	146	182	28	1	8	7	0.16
BHFGP2912	187	234	28	1	12	14	0.30
BHFGP2918	229	284	28	1	18	14	0.30
BHFGP2924	251	313	28	1	24	17	0.40
BHFGP2930	339	420	28	1	30	21	0.50
BHFGP2936	422	528	28	1	36	26	0.65

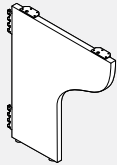
BHPG • "P" Shaped Full Gable - 3mm PVC Edged

- Provides floor standing support while enclosing an end of a run of worksurfaces.
- Includes attachment hardware, Bracket Retainer Clip and levelling glides.
- Handed due to hardware attachment and PVC edge.

PRODUCT CODE	PRICE LP*	GROUP HP*	SIZE/ INCHES			WEIGHT VOL	
			H	W	D	LBS	FT ³
BHPG2624L	251	313	25	1	24	19	0.36
BHPG2924L	251	313	28	1	24	17	0.40
BHPG2624R	251	313	25	1	24	19	0.36
BHPG2924R	251	313	28	1	24	17	0.40

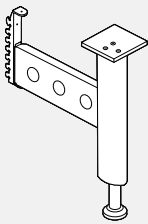
BHLEG • Gable Leg

- Support the worksurface and enhances the stability of connected panels.
- Universal leg plate bolts to the underside of the worksurface.
- Can be configured on-site for left, right or shared worksurface support application on front edge
- Back edge does not have shared support.
- Tubular leg section adjusts in 1" increments, the leveller can be used for fine adjustment.
- 1" increment leg adjustment and 1" increment panel slots allow the leg of installed worksurface to be supported from 26" to 32". (Leg must be removed from panel to manually adjust.)
- Side plate is secured to the slots in the vertical of the Boulevard 1 or System 3 panels and the leg plate bolts to underside of the worksurface.
- Made of extruded aluminum and steel.
- Includes all mounting hardware to connect to panel and worksurface.

PRODUCT CODE	PRICE	GROUP	SIZE/ INCHES			WEIGHT VOL	
			H	W	D	LBS	FT ³
BHLEG	211		28	6	23	8	0.15

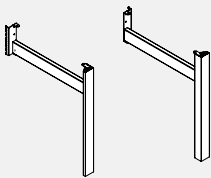
BRTBLEG • Boulevard Leg Assembly

- Boulevard Leg Assembly attaches to a Boulevard panel for applications which require functionality of Boulevard panels with an open environment of Bridges tables.
- One leg with horizontal member connecting to 1" increment slots in panel's vertical frame member. Provides support to panel and panel-connected worksurface at the end of a run; design coordinated with Bridges freestanding tables.
- Supports 24" and 30" deep worksurfaces. By adding 2 BHBF01 flat brackets and 1 BHBC02 corner bracket, a single leg can then support the adjoining worksurface. Leveling glide is standard. No worksurface supporting beams, use panel cantilevers and storage for worksurface support. One aluminum leg with steel structure - specify Left or Right and 24" or 30" deep for corresponding worksurface depths. Panel bracket, dislodgment clip and worksurface hardware included.
- Anodized aluminum leg upcharge \$31.
- Please specify paint finish for support.

PRODUCT CODE	PRICE	GROUP	SIZE/ INCHES			WEIGHT VOL	
			H	W	D	LBS	FT ³
BRTBLEG24LL	317		28	2.5	24	9	1.25
BRTBLEG24RL	317		28	2.5	24	9	1.25
BRTBLEG30LL	333		28	2.5	30	11	1.45
BRTBLEG30RL	333		28	2.5	30	11	1.45

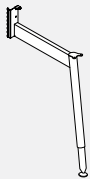
BRTBL • Boulevard Leg Assembly

- Boulevard Leg Assembly attaches to a Boulevard panel for applications which require functionality of Boulevard panels with an open environment of Bridge 2 tables.
- Panel bracket secures the leg to the panel in 1" increments, within a 24" to 32" height range.
- Panel mounting bracket is reversible for non-handed applications.
- Supports 24" and 30" deep worksurfaces. By adding 2 BHBF01 flat brackets and 1 BHBC02 corner bracket, a single leg can then support the adjoining worksurface. Leveling glide is standard. No worksurface supporting beams, use panel cantilevers and storage for worksurface support. Panel bracket, dislodgment clip and worksurface hardware included.
- Leveling glide is standard.

PRODUCT CODE	PRICE	GROUP	SIZE/ INCHES			WEIGHT VOL	
			H	W	D	LBS	FT ³
BRTBL	338		28	3	24	12	1.25

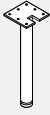
BHML • Monoleg

- **3" diameter Monoleg provides support for worksurfaces.**
- Top plate welded to leg.
- 8" x 8" plated attached to worksurface with #10 3/4" wood screws, included.
- 1" height adjustment range.
- For chrome finish on leg, please add \$109 list upcharge.

PRODUCT CODE	PRICE	SIZE/ INCHES			WEIGHT VOL	
		H	W	D	LBS	FT ³
BHML03	207	28	3	3	8	0.15

LATBL • Tapered Leg

- **Tapered leg provides support for worksurfaces.**
- Top plate welded to leg.
- 8" x 8" plated attached to worksurface with #10 3/4" wood screws, included.
- 1" height adjustment range.
- For chrome finish on leg, please add \$109 list upcharge.

PRODUCT CODE	PRICE	SIZE/ INCHES			WEIGHT VOL	
		H	W	D	LBS	FT ³
LATBL28	195	28	3	3	8	0.15

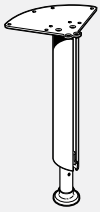
VVLEGLV • Leg with Leveler

- **The Viceversa leg features a push button height adjustment mechanism. This mechanism allows the user to easily set the height of a table. The universal mounting plate can be used to gang 2 tables without metal skirt simply by rotating 45 degrees to span both tops.**
- The Viceversa Leg has a wire management channel that neatly organizes electrical and communication cables running from the worksurface to the floor.
- Legs have a height range of 25" to 32" in 1" increments (includes 1" top).
- The wire channel is covered by a clear PVC snap-on cover.
- Levelers have a 1/2" height range.
- Levelers come in charcoal only.
- Includes mounting hardware.

PRODUCT CODE	PRICE	SIZE/ INCHES			WEIGHT VOL	
		H	D	W	LBS	FT ³
VVLEGLV	182	25-32	8	10	8	1.5

VVLEGLC • Leg with Caster

- **The Viceversa leg features a push button height adjustment mechanism. This mechanism allows the user to easily set the height of a table. The universal mounting plate can be used to gang 2 tables without metal skirt simply by rotating 45 degrees to span both tops.**
- The Viceversa Leg has a wire management channel that neatly organizes electrical and communication cables running from the worksurface to the floor.
- Legs have a height range of 26" to 33" in 1" increments.
- The wire channel is covered by a clear PVC snap-on cover.
- Casters come in grey with black only.
- Includes mounting hardware.

PRODUCT CODE	PRICE	SIZE/ INCHES			WEIGHT VOL	
		H	D	W	LBS	FT ³
VVLEGLC	182	26-33	8	10	8	1.5

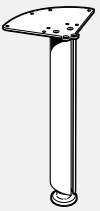
VVLEGF • Fixed Height Leg

- **The Viceversa fixed height leg with leveler supports the worksurface at a fixed height of 29".**
- The Viceversa leg has a wire management channel that neatly organizes electrical and communication cables running from the worksurface to the floor.
- Leg can be installed for each corner of the worksurface or can be shared at adjoining surfaces.
- The wire channel is covered by a clear PVC snap-on cover.
- Levelers have a 1/2" height range.
- Levelers come in charcoal only.
- Includes mounting hardware.

PRODUCT CODE	PRICE	SIZE/ INCHES			WEIGHT VOL	
		H	D	W	LBS	FT ³
VVLEGF	145	28	8	10	8	1.5

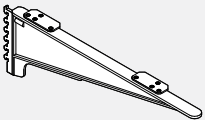
BHC • Cantilever

- **Universal cantilever with steel attachment bracket constructed of cast aluminum to provide support for worksurfaces.**
- Attaches a worksurface to a panel.
- May be used for shared worksurface support.
- Interchangeable in the field for left or right positioning.
- Includes Bracket Retainer Clip.

PRODUCT CODE	PRICE	SIZE/ INCHES			WEIGHT VOL	
		H	W	D	LBS	FT ³
BHC18	104	7	17	2.5	17	0.04
BHC24	122	7	23	2.5	23	0.05

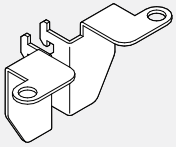
BHBC • Corner End Bracket

- Formed steel bracket for a corner worksurface or a straight worksurface.
- Attaches a corner of any worksurface to a panel through the panel vertical slots.
- Priced one left and one right per package.
- Includes Bracket Retainer Clip.

PRODUCT CODE	PRICE	SIZE/ INCHES			WEIGHT VOL	
		H	W	D	LBS	FT ³
BHBC02	26	3.3	1.5	2.3	2	0.007

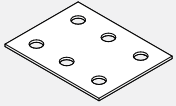
BHBF • Flat Bracket

- Flat Bracket made of cold rolled steel.
- May be used to ensure alignment of neighboring worksurfaces.

PRODUCT CODE	PRICE	SIZE/ INCHES			WEIGHT VOL	
		H	W	D	LBS	FT ³
BHBF01	13	0.1	3	4	0.5	0.007

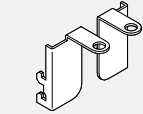
BHBT • Transaction Bracket

- For use on 34", 42", 50", 58", 66", 74" and 82" high Boulevard panels.
- Transaction Bracket made of cold rolled steel.
- To provide a secure attachment of a transaction worksurface.
- Priced one left and one right per package.
- Includes Bracket Retainer Clip.

PRODUCT CODE	PRICE	SIZE/ INCHES			WEIGHT VOL	
		H	W	D	LBS	FT ³
BHBT02	26	3.3	1.5	2.3	2	0.001

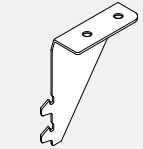
BHBT • Transaction Bracket for 37" High Boulevard 1 Panels

- Transaction Bracket made of cold rolled steel.
- To provide a secure attachment of a transaction worksurface for a 37" high Boulevard 1 panel only. Transaction Bracket engages with the top slots in the 37" high panel to supported for the transaction worksurface.
- Priced one left and one right per package.
- Includes Bracket Retainer Clip.

PRODUCT CODE	PRICE	SIZE/ INCHES			WEIGHT VOL	
		H	W	D	LBS	FT ³
BHBT37	31	4	1	3	0.5	0.007

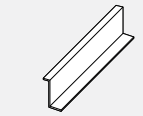
BHBZ • "Z" Bracket

- Attaches two different heights of worksurfaces.
- To be used in conjunction with a cantilever.

PRODUCT CODE	PRICE	SIZE/ INCHES			WEIGHT VOL	
		H	W	D	LBS	FT ³
BHBZ03	81	4	21	4	2	0.190

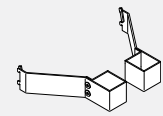
FTATB • Boulevard Connector Kit

- FreeFit to Boulevard kit secures FreeFit height adjustable freestanding tables to parallel Boulevard panels.
- It provides panel/table alignment, preventing moving parts from rubbing against panel vertical surfaces and maintains 1" clearance around table surface perimeter.
- Standard metal finishes.
- All hardware included.
- Sold as a pair.

PRODUCT CODE	PRICE	SIZE/ INCHES			WEIGHT VOL	
		H	W	D	LBS	FT ³
FTATB	144	10	6.5	10	7.00	0.50

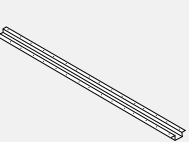
LHC • HAT Channel

PRODUCT CODE	PRICE	SIZE/ INCHES			WEIGHT VOL	
		H	W	D	LBS	FT ³
LHC40	58	1.4	40	5	4	0.20
LHC46	64	1.4	46	5	6	0.22
LHC52	68	1.4	52	5	7	0.25
LHC58	78	1.4	58	5	8	0.28
LHC64	88	1.4	64	5	9	0.31
LHC70	94	1.4	70	5	10	0.33

Technical Information for 9300 Series Pedestals

General Information:

9300 Series Pedestals feature center pull handles (models ending in "C") and full pull handles (models ending in "P"). Freestanding, mobile, and worksurface supporting options available. Quality steel construction. File drawers hold letter or A4 front to back and legal side to side configurations. Products are finished in a highly durable dry epoxy powder coating and drawer body interiors are finished with 100% recycled paint. Counterweights are included in freestanding and mobile pedestals to meet applicable ANSI/BIFMA X5.9.

Features:

- Cold rolled steel construction consisting of 16 ga front and back base with 22 ga case
- Reinforced welded construction
- Inset drawer fronts and flush base
- Double wall construction on all drawer fronts
- Full extension ball bearing slides on file drawers and $\frac{3}{4}$ extension on box drawers
- Rubber bumpers on slides for quietness
- Worksurface supporting option available (includes mounting holes at top of unit)
- 1 pencil tray and 1 drawer divider are included with each unit containing a box drawer
- Each file drawer includes a hanging file bar
- Levelers provide 1" height adjustment
- Counterweights included for freestanding and mobile pedestals
- Includes lock with 2 keys
- Lock is located at the top right of the case above the top drawer
- Keyed alike option available and can be keyed alike to other storage components

Technical Information for Prime Series

General Information:

Prime premium filing and storage products pre-configured to suit your needs; featuring fixed front or receding doors with center pull handles and fully welded seamless tops to deliver strength and clean aesthetics. Premium quality steel construction. File drawers accommodate legal, letter or A4 sizes in back-to-front and side-to-side configurations. Products are finished in a highly durable dry epoxy powder coating and drawer body interiors are finished with 100% recycled paint.

Counterweights are recommended for use in all laterals, pedestals and freestanding files of all widths and heights to meet applicable ANSI/BIFMA X5.9. (Counterweights are offered as an option on all products where required to meet applicable ANSI/BIFMA standard)

Features

- Premium steel construction, 18-22 gauge steel components
- Full welded and reinforced case construction
- Interlock system allows only one drawer to open at a time for safety
- Most products feature full overlay fronts, with some exceptions such as units with receding doors where the front is inset in the case
- Double wall construction on all drawer and door fronts
- Full extension roller bearing glides on all drawers
- Anti-bounce-back safety feature prevents drawers from sliding open
- Receding doors slide into the cabinet and allow the shelf to be pulled out
- All pedestals are equipped with four levelling glides, providing 1.5" of height adjustment
- All other units equipped with four levelling glides providing 1" height adjustment and can be accessed from the interior of the cabinets for ease of adjustment
- On units with drawers and hinged doors, locks are located at the center of the case above the top opening
- Lock position on towers with wardrobes is below the handle when center pull is selected
- Each lock includes 2 keys; locks are standard with removable cores
- Key assignment is random or can be specified for specific key number for key alike applications

Overhead Storage:

- Overhead cabinets - 7 widths in 6" increments
- 14 5/8" high cases with interior clear height of 12"
- 13" deep units have interior clear dimension of 12.7"
- 16" deep units have interior clear dimension of 15.7"
- Open shelves - 7 widths in 6" increments
- Shelves are 12 1/2" deep with 7 1/2" high side gables

Sizes:

- 15" width
- 19", 23", 29" depths
- Interior drawer depths:

19" Deep pedestals
17 1/4" deep box drawers
16 1/16" deep file drawers

23" deep pedestals
20 3/16" deep box drawers
19 7/16" deep file drawers

29" deep pedestals
26 5/16" deep box drawers
26 1/16" deep file drawers

Drawer Heights:

Box drawer fronts are 6"H with 5" interior height
File drawer fronts are 12"H with 10 9/16" interior height

Pedestals:

- Freestanding and worksurface supporting options available
- Worksurface supporting includes mounting holes at top of unit
- 1 pencil tray and 1 drawer divider are included with each unit containing a box drawer
- File drawers hold legal, letter or A4 sizes in back-to-front and side-to-side configurations
- Each file drawer includes a hanging file bar and conversion rails
- Freestanding units BSPF can be specified with optional non-locking casters to convert to a mobile unit
- 15" width x 18", 22", 28" depths

Interior drawer depth is as follows:

- 15" deep drawers for 18" deep pedestals
- 19" deep drawers for 22" deep pedestals
- 25" deep drawers for 28" deep pedestals

File drawer capacity:

- 14 3/8" filing capacity for file drawers in 18" pedestal
- 18 3/8" filing capacity for file drawers in 22" pedestal
- 24 3/8" filing capacity for file drawers in 28" pedestal

Laterals:

- 18" depth with interior depth of 16"
- 30", 36", 42" widths
- Available in 2 to 6 drawer high (28"h - 77.6"h)

File Drawer Capacity:

30" wide units

- Letter & legal side-to-side = 26 5/8"
- Letter front-to-back = 30 1/2"
- Legal front-to-back = 15 1/4" + 10" side space

36" wide units

- Letter & legal side-to-side = 32 5/8"
- Letter front-to-back = 30 1/2" + 6 1/2" side space
- Legal front-to-back = 30 1/2"

42" wide units

- Letter & legal side-to-side = 58 5/8"
- Letter front-to-back = 45 3/4"
- Legal front-to-back = 30 1/2" + 6 1/2" side space

Technical Information for Prime Series

Storage Cabinets:

- 18" depth
- 30", 36", 42" widths
- Available in 2 to 5 high configurations (28"h – 65.6"h)

Towers:

- Include coat rod and shelf to accommodate personal items
- The top of the storage compartment is perforated for ventilation

- Includes locks with 2 keys each
 - Closed storage comes with 3 locks – one of the drawers, one for the cupboard, and one for the wardrobe
 - Side open storage comes with 2 locks – one of the drawers and one for the wardrobe
- 24" width
- 50", 54", and 66" nominal heights available to coordinate with Global's panel systems

STORAGE COMPONENTS - GUIDELINES FOR ORDERING PRODUCT

Codes

The price list uses a numbering system with meaningful alphanumeric characters to create a simple-to-understand product number. This makes specifying the product much easier and more accurate.

How to Specify

- Specify storage pedestal type and size by code, including depth.
- Specify metal color (eg. BLK for Black)
- Specify key random, key list provided, or key number (eg. 401)
- Specify worksurface supporting (1 = Yes, 2 = No)
- Specify counterweight if pedestal is not worksurface supporting (NN = No Counterweight)

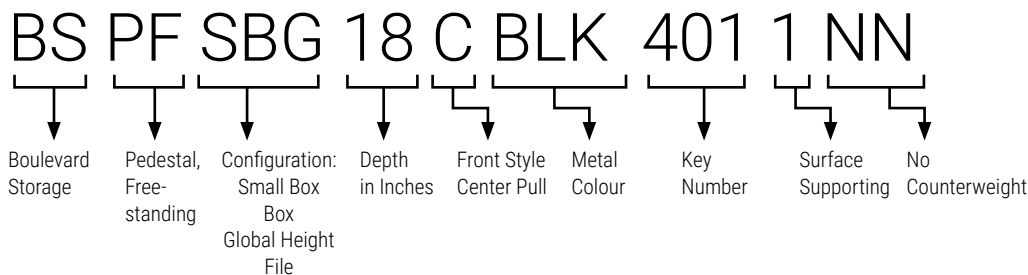

BSKSS • Panel Mount Shelf

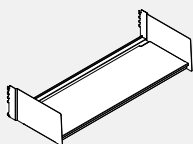

- 14" deep panel mounted storage shelf with backlip.
- Mounting brackets are included.

PRODUCT CODE	PRICE	SIZE/INCHES			WEIGHT LBS	VOL FT ³
		H	W	D		
BSKSS24	133	7.45	23.44	14.73	12.8	1.5
BSKSS30	141	7.45	29.44	14.73	14.8	1.9
BSKSS36	155	7.45	35.44	14.73	16.8	2.3
BSKSS42	161	7.45	41.44	14.73	18.8	2.6
BSKSS48	172	7.45	47.44	14.73	20.8	3.0
BSKSS54	179	7.45	53.44	14.73	22.8	3.4
BSKSS60	184	7.45	59.44	14.73	24.8	3.8

BLSLF • Flush Front Overhead Cabinet

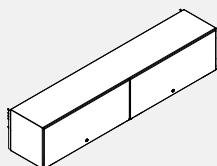
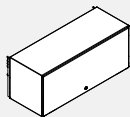

- Flush Front Overhead Cabinet is panel mounted lockable storage unit.
- The door retracts inside/within the overhead cabinet.
- Locks can be keyed alike to match other lockable storage components or keyed random to provide a dedicated lock.
- Available in 13" and 16" depths, 24" to 60" widths at 6" increments.
- Cabinets 54" and 60" wide come with two doors.
- Includes mounting hardware as specified, lock and keys.
- Lock secures into bottom shelf.
- Can be mounted at any height, however 66"h panels are recommended.
- Shipped assembled.

Cabinets 54" and 60" wide come with two doors

PRODUCT CODE	PRICE	SIZE/INCHES			WEIGHT LBS	VOL FT ³
		H	W	D		
BLSLF1324MN	540	14.62	23.87	13.5	39.3	2.7
BLSLF1330MN	558	14.62	29.87	13.5	44.3	3.4
BLSLF1336MN	614	14.62	35.87	13.5	49.3	4.1
BLSLF1342MN	672	14.62	41.87	13.5	54.3	4.8
BLSLF1348MN	731	14.62	47.87	13.5	59.3	5.5
BLSLF1354MN	788	14.62	53.87	13.5	64.3	6.2
BLSLF1360MN	844	14.62	59.87	13.5	69.3	6.8
BLSLF1624MN	893	14.62	23.87	16.5	38.6	3.4
BLSLF1630MN	916	14.62	29.87	16.5	43.9	4.2
BLSLF1636MN	960	14.62	35.87	16.5	49.2	5.0
BLSLF1642MN	1024	14.62	41.87	16.5	54.5	5.8
BLSLF1648MN	1089	14.62	47.87	16.5	59.8	6.7
BLSLF1654MN	1148	14.62	53.87	16.5	65.1	7.5
BLSLF1660MN	1200	14.62	59.87	16.5	70.4	8.4

BSADA-PM • Panel Mounted Overhead Storage Unit - AODA Compliant

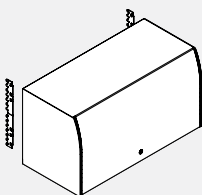

- Panel mounted metal overhead storage with opaque acrylic door. The mechanism lifts the door up and stores it out of the way, above the storage unit.
- Meets CSA B651 Barrier Free Design & AODA (Accessibility for Ontarians with Disabilities Act).
- 16" high units accept standard and A4 binders.
- All shelves are reinforced for proper weight distribution.
- Inside dimensions: 14.25" high x 13.4" deep.
- Unit includes attachment hardware, lock and mounting brackets. Back not included.
- Not recommended for use with wall rails.
- Unit can be converted to Up-Mount Overhead Storage Unit in the field by adding BSADAxKIT.
- Shipped partially assembled.

PRODUCT CODE	PRICE	SIZE/INCHES			WEIGHT LBS	VOL FT ³
		H	W	D		
BSADA24PM	780	16	24	14.2	22	4.3
BSADA30PM	839	16	30	14.2	27	5.3
BSADA36PM	906	16	36	14.2	32	6.3
BSADA42PM	970	16	42	14.2	37	7.3
BSADA48PM	1037	16	48	14.2	42	8.3
BSADA54PM	1101	16	54	14.2	47	9.3
BSADA60PM	1167	16	60	14.2	53	10.3

BSADA-UM • Up-Mount Overhead Storage Unit - AODA Compliant

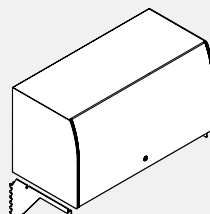

- Up mounted storage can reduce furniture costs by reducing the height of all panels to 50". Complete 50" panel installations simplify cable routing at one level, within the top lay-in channel. Up-mounted cantilevers maintain accessibility and functionality of the panels' top lay-in channel.
- Meets CSA B651 Barrier Free Design & AODA (Accessibility for Ontarians with Disabilities Act).
- 16" high units accept standard and A4 binders.
- All shelves are reinforced for proper weight distribution.
- Inside dimensions: 14.25" high x 13.4" deep.
- Unit includes attachment hardware, lock, mounting cantilevers and has a finished back.
- Unit can be converted to a Panel Mounted Overhead Storage Unit in the field by adding BSADAPMxxKIT.
- Shipped partially assembled.

PRODUCT CODE	PRICE	SIZE/INCHES			WEIGHT LBS	VOL FT ³
		H	W	D		
BSADA24UM	956	16	24	14.2	25	4.3
BSADA30UM	999	16	30	14.2	33	5.3
BSADA36UM	1046	16	36	14.2	40	6.3
BSADA42UM	1105	16	42	14.2	46	7.3
BSADA48UM	1166	16	48	14.2	53	8.3
BSADA54UM	1222	16	54	14.2	59	9.3
BSADA60UM	1293	16	60	14.2	66	10.3

BSADA-KIT • Up-Mount Conversion Kit

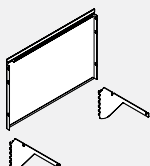

- Converts an existing Panel Mounted Overhead Storage Unit BSADA-PM to an Up-Mounted Overhead Storage unit BSADA-UM.
- When used on a 50" high panel, the top of the overhead will match the height of 66" high panels.
- Kit includes a back panel for the Overhead and Up-Mount Cantilevers.

PRODUCT CODE	PRICE	SIZE/INCHES			WEIGHT LBS	VOL FT ³
		H	W	D		
BSADA24KIT	194	16	24	2	6	0.6
BSADA30KIT	201	16	30	2	8	0.6
BSADA36KIT	210	16	36	2	10	0.7
BSADA42KIT	225	16	42	2	11	0.8
BSADA48KIT	235	16	48	2	13	0.9
BSADA54KIT	247	16	54	2	14	1.0
BSADA60KIT	261	16	60	2	15	1.1

BSADA-OMKIT • Off-Module Conversion Kit

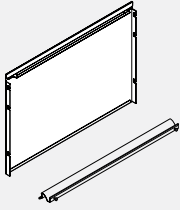

- Converts an existing Panel Mounted Storage Unit BSADA-PM to Off-Module Overhead Storage unit BSADA-OMKIT.
- Kit includes a back panel with integrated hanging bracket and an extruded bottom bracket.
- **IMPORTANT:** BSADA Overhead with Off-Module Conversion kit can only be installed on B3 fabric tile. Tiles below the overhead can be fabric, laminate and accessory tile. However, the tile the overhead is hanging on must be fabric.
- BSADA Overhead with Off-Module Conversion Kit can be suspended off of a single fabric tile, or can span two fabric tiles on two adjacent, directly interconnected panels.
- BSADA Overhead with Off-Module Conversion Kit **CANNOT** be suspended off of two panels separated by a post.

PRODUCT CODE	PRICE	SIZE/INCHES			WEIGHT VOL	
		H	W	D	LBS	FT ³
BSADA240MKIT	194	16	24	2	6	0.5
BSADA300MKIT	201	16	30	2	8	0.6
BSADA360MKIT	210	16	36	2	10	0.7
BSADA420MKIT	225	16	42	2	11	0.8
BSADA480MKIT	235	16	48	2	13	0.9
BSADA540MKIT	247	16	54	2	14	1.0
BSADA600MKIT	261	16	60	2	15	1.1

BSADA-KIT • Panel Mount Conversion Kit



- Converts an existing Up-Mount Overhead Storage Unit BSADA-UM to a Panel Mounted Overhead Storage Unit BSADA-PM.
- Kit includes panel mounting brackets.

PRODUCT CODE	PRICE	SIZE/INCHES			WEIGHT VOL	
		H	W	D	LBS	FT ³
BSADAPMKIT	40	16	0.5	2	2	0.009

BSP1DO • Overhead Divider Storage for Boulevard 1 - Open Double Sided

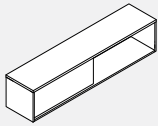

- Panel top mount allows access on both sides.
- Storage compartment internal height: 14".
- Overhead available in standard GC laminate finishes.
- Top mount on panels.
- Connecting hardware included.

PRODUCT CODE	PRICE		SIZE/INCHES			WEIGHT VOL	
	LP	HP	H	W	D	LBS	FT ³
BSP1DO36	655	737	16	36	16	81	7
BSP1DO42	675	766	16	42	16	96	8
BSP1DO48	700	808	16	48	16	100	9

BSP1LDS • Overhead Divider Storage for Boulevard 1 - Open Double Sided with Sliding Laminate Door

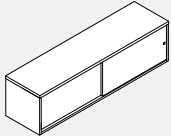

- Panel top mount allows access on both sides.
- Storage compartment internal height: 14".
- Overhead available in standard GC laminate finishes.
- Top mount on panels.
- Connecting hardware included.
- Sliding laminate doors are not locking.

PRODUCT CODE	PRICE		SIZE/INCHES			WEIGHT VOL	
	LP	HP	H	W	D	LBS	FT ³
BSP1LDS36	2057	2136	16	36	16	87	7
BSP1LDS42	2103	2199	16	42	16	103	8
BSP1LDS48	2131	2240	16	48	16	108	9

BSP1GDS • Overhead Divider Storage for Boulevard 1 - Open Double Sided with Sliding Glass Door

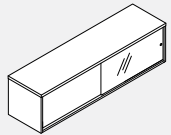

- Panel top mount allows access on both sides.
- Storage compartment internal height: 14".
- Overhead available in standard GC laminate finishes.
- Top mount on panels.
- Connecting hardware included.
- Sliding glass doors are not locking.

PRODUCT CODE	PRICE		SIZE/INCHES			WEIGHT VOL	
	LP	HP	H	W	D	LBS	FT ³
BSP1GDS36	2129	2210	16	36	16	92	7
BSP1GDS42	2165	2261	16	42	16	108	8
BSP1GDS48	2196	2304	16	48	16	113	9

BSP3DO • Overhead Divider Storage for Boulevard System 3 - Open Double Sided

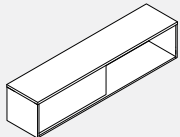

- Panel top mount allows access on both sides.
- Storage compartment internal height: 14".
- Overhead available in standard GC laminate finishes.
- Top mount on panels.
- Connecting hardware included.

PRODUCT CODE	PRICE		SIZE/INCHES			WEIGHT VOL	
	LP	HP	H	W	D	LBS	FT ³
BSP3DO36	633	716	16	36	16	81	9
BSP3DO42	660	756	16	42	16	96	10.5
BSP3DO48	689	796	16	48	16	100	12

BSP3LDS • Overhead Divider Storage for Boulevard System 3 - Open Double Sided with Sliding Laminate Door

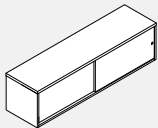

- Panel top mount allows access on both sides.
- Storage compartment internal height: 14".
- Overhead available in standard GC laminate finishes.
- Top mount on panels.
- Connecting hardware included.
- Sliding laminate doors are not locking.

PRODUCT CODE	PRICE		SIZE/INCHES			WEIGHT VOL	
	LP	HP	H	W	D	LBS	FT ³
BSP3LDS36	2036	2117	16	36	16	106	7
BSP3LDS42	2086	2178	16	42	16	126	8
BSP3LDS48	2110	2221	16	48	16	134	9

BSP3GDS • Overhead Divider Storage for Boulevard System 3 - Open Double Sided with Sliding Glass Door

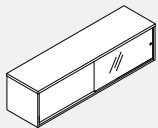

- Panel top mount allows access on both sides.
- Storage compartment internal height: 14".
- Overhead available in standard GC laminate finishes.
- Top mount on panels.
- Connecting hardware included.
- Sliding glass doors are not locking.

PRODUCT CODE	PRICE		SIZE/INCHES			WEIGHT VOL	
	LP	HP	H	W	D	LBS	FT ³
BSP3GDS36	2108	2190	16	36	16	87	6
BSP3GDS42	2143	2240	16	42	16	103	7
BSP3GDS48	2174	2284	16	48	16	107	9

BS93FPxxBFC • 9300 Series Freestanding Box File Pedestal

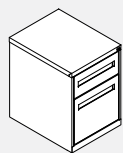

- One box and one file drawer pedestal.
- Freestanding, counterweight included.
- All drawers are locking.
- Box drawer includes pencil tray.

PRODUCT CODE	PRICE	SIZE/INCHES			WEIGHT LBS	VOL FT ³
		H	W	D		
BS93FP19BFC	559	21.31	15	19	50	5.1
BS93FP23BFC	566	21.31	15	23	55	6.0
BS93FP29BFC	678	21.31	15	29	64	7.5

BS93FPxxBBFC • 9300 Series Freestanding Box Box File Pedestal

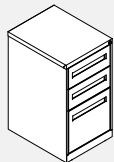

- Two box and one file drawer pedestal.
- Freestanding, counterweight included.
- All drawers are locking.
- Top box drawer includes pencil tray.

PRODUCT CODE	PRICE	SIZE/INCHES			WEIGHT LBS	VOL FT ³
		H	W	D		
BS93FP19BBFC	617	27.87	15	19	55	6.5
BS93FP23BBFC	628	27.87	15	23	68	7.7
BS93FP29BBFC	741	27.87	15	29	78	9.6

BS93FPxxFFC • 9300 Series Freestanding File File Pedestal

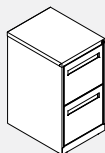

- Two file drawer pedestal.
- Freestanding, counterweight included.
- All drawers are locking.

PRODUCT CODE	PRICE	SIZE/INCHES			WEIGHT LBS	VOL FT ³
		H	W	D		
BS93FP19FFC	589	27.87	15	19	53	6.5
BS93FP23FFC	597	27.87	15	23	60	7.7
BS93FP29FFC	699	27.87	15	29	70	9.6

BS93WPxxBBFC • 9300 Series Worksurface Supporting Box Box File Pedestal

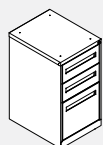

- Two box and one file drawer pedestal.
- Worksurface supporting, includes mounting holes in the top.
- All drawers are locking.
- Top box drawer includes pencil tray.
- Includes filler and brackets.

PRODUCT CODE	PRICE	SIZE/INCHES			WEIGHT LBS	VOL FT ³
		H	W	D		
BS93WP19BBFC	613	27.87	15	19	55	6.5
BS93WP23BBFC	621	27.87	15	23	68	7.7
BS93WP29BBFC	711	27.87	15	29	78	9.6

BS93WPxxFFC • 9300 Series Worksurface Supporting File File Pedestal

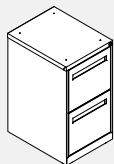

- Two file drawer pedestal.
- Worksurface supporting, includes mounting holes in the top.
- All drawers are locking.
- Includes filler and brackets.

PRODUCT CODE	PRICE	SIZE/INCHES			WEIGHT LBS	VOL FT ³
		H	W	D		
BS93WP19FFC	582	27.87	15	19	53	6.5
BS93WP23FFC	587	27.87	15	23	60	7.7
BS93WP29FFC	700	27.87	15	29	70	9.6

BS93MPxxBFC • 9300 Series Mobile Box File Pedestal

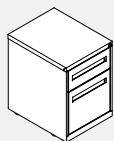

- One box and one file drawer mobile pedestal.
- Casters preinstalled, casters non-locking.
- Counterweight included.
- All drawers locking.
- Box drawer includes pencil tray.
- NOTE: Cannot be used as guest seating.

PRODUCT CODE	PRICE	SIZE/INCHES			WEIGHT LBS	VOL FT ³
		H	W	D		
BS93MP19BFC	659	21.87	15	19	66	5.2
BS93MP23BFC	681	21.87	15	23	72	6.2
BS93MP29BFC	730	21.87	15	29	92	7.6

BS93MPxxBBFC • 9300 Series Mobile Box Box File Pedestal

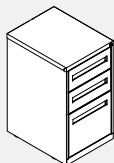

- Two box and one file drawer mobile pedestal.
- Casters preinstalled, casters non-locking.
- Counterweight included.
- All drawers locking.
- Top box drawer includes pencil tray.
- NOTE: Cannot be used as guest seating.

PRODUCT CODE	PRICE	SIZE/INCHES			WEIGHT LBS	VOL FT ³
		H	W	D		
BS93MP19BBFC	695	27.93	15	19	76	6.5
BS93MP23BBFC	702	27.93	15	23	85	7.7
BS93MP29BBFC	757	27.93	15	29	94	9.6

BS93MPxxFFC • 9300 Series Mobile File File Pedestal

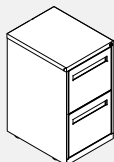

- Two file drawer pedestal.
- Casters preinstalled, casters non-locking.
- Counterweight included.
- All drawers locking.
- NOTE: Cannot be used as guest seating.

PRODUCT CODE	PRICE	SIZE/INCHES			WEIGHT LBS	VOL FT ³
		H	W	D		
BS93MP19FFC	654	27.93	15	19	73	6.5
BS93MP23FFC	681	27.93	15	23	81	7.7
BS93MP29FFC	748	27.93	15	29	90	9.6

BSPF0BFxxC • Prime Freestanding Box File Pedestal

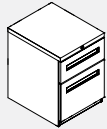

- One box and one file drawer pedestal.
- All drawers are locking.
- Box drawer includes pencil tray.
- For freestanding, to add counterweight (W2 option), add \$50 list.
- For mobile to add casters and counterweight (W1 option), add \$75 list. Adds 0.5" to height.
- NOTE: Cannot be used as guest seating.

PRODUCT CODE	PRICE	SIZE/INCHES			WEIGHT VOL	
		H	W	D	LBS	FT³
BSPF0BF18C	571	20.8	15	18	52.4	4.2
BSPF0BF22C	579	20.8	15	22	58.8	5.0
BSPF0BF28C	656	20.8	15	28	68.7	6.3

BSPFSBGxxC • Prime Box Box File Pedestal

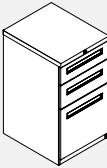

- Two box and one file drawer pedestal.
- All drawers are locking.
- Top box drawer includes pencil tray.
- For freestanding, to add counterweight (W2 option), add \$50 list.
- For mobile to add casters and counterweight (W1 option), add \$75 list. Adds 0.5" to height.
- Top box drawer 4.8"h; middle box drawer 6.4"h; bottom file drawer 13.6"h (interior 12.5"h).
- When worksurface supporting option selected, unit includes pre-drilled top holes for attaching and filler/brackets.

PRODUCT CODE	PRICE	SIZE/INCHES			WEIGHT VOL	
		H	W	D	LBS	FT³
BSPFSBG18C	637	28	15	18	67.5	5.5
BSPFSBG22C	644	28	15	22	75.0	6.6
BSPFSBG28C	710	28	15	28	86.8	8.3

BSPF0FGxxC • Prime File File Pedestal

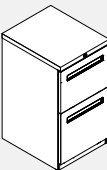

- Two file drawer pedestal.
- All drawers are locking.
- For freestanding, to add counterweight (W2 option), add \$50 list.
- For mobile to add casters and counterweight (W1 option), add \$75 list. Adds 0.5" to height.
- Top file drawer 11.2"h (interior 10.6"h); bottom file drawer 13.6"h (interior 12.5"h).
- When worksurface supporting option selected, unit includes pre-drilled top holes for attaching and filler/brackets.

PRODUCT CODE	PRICE	SIZE/INCHES			WEIGHT VOL	
		H	W	D	LBS	FT³
BSPF0FG18C	637	28	15	18	67.5	5.5
BSPF0FG22C	644	28	15	22	75.0	6.6
BSPF0FG28C	710	28	15	28	86.8	8.3

BSPW0BFxxC • Prime Mobile Box File Pedestal



- Mobile one box and one file drawer pedestal.
- All drawers are locking.
- 60mm casters.
- Front casters are locking.

PRODUCT CODE	PRICE	SIZE/INCHES			WEIGHT VOL	
		H	W	D	LBS	FT³
BSPW0BF18C	758	23.3	15	18	73.5	4.6
BSPW0BF22C	763	23.3	15	22	79.1	5.6
BSPW0BF28C	878	23.3	15	28	87.7	7.0

BSTC • Pedestal/Lateral Seat Cushion

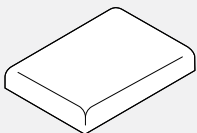

PRODUCT CODE	YRDS	SIZE/ INCHES			WEIGHT VOL	
		H	W	D	LBS	FT³
BSTCP1518	0.75	2	15	18	5.00	0.41
BSTCP1522	0.75	2	15	22	5.25	0.45
BSTCP1528	1.00	2	15	28	5.5	0.55
BSTCL1830	1.00	2	18	30	6.0	0.55
BSTCL1836	1.25	2	18	36	6.5	0.65

PRODUCT CODE	PRICE	GR																		
		GR1	GR2	GR3	GR4	GR5	GR6	GR7	GR8	GR9	GR10	GR11	GR12	GR13	GR14	GR15	GR16	GR17	GR18	GR19
BSTCP1518	202	233	252	280	323	364	401	435	477	518	574	652	724	802	972	1142	1312	1482	1652	1839
BSTCP1522	212	240	264	291	333	372	411	448	486	528	582	659	736	813	984	1153	1324	1495	1661	1848
BSTCP1528	267	305	336	371	426	480	534	579	631	688	759	864	964	1065	1294	1517	1747	1973	2198	2448
BSTCL1830	289	328	355	394	450	503	552	603	655	712	783	886	987	1089	1317	1541	1772	1996	2221	2471
BSTCL1836	343	391	430	475	543	608	673	733	801	869	960	1089	1214	1343	1628	1908	2194	2474	2757	3070

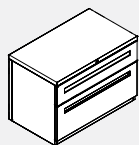
BSLPS0BF18xxC • Prime Box File Lateral

- One and a half height lateral filing cabinet.
- Fixed front drawers, top box drawer front 4.8" bottom file drawer front 13.6" (interior 12.5").
- Locking.
- Side to side hanging bars included.
- To add counterweight (W2 option), add \$410 list.

PRODUCT CODE	PRICE	SIZE/INCHES			WEIGHT LBS	VOL FT ³
		H	W	D		
BSLPS0BF1830C	1268	20.98	30	18.06	119.96	8.0
BSLPS0BF1836C	1320	20.98	36	18.06	129.86	9.5
BSLPS0BF1842C	1364	20.98	42	18.06	165.45	11.1

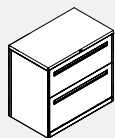
BSLF20G18xxC • Prime 2 High Lateral File

- Two high lateral filing cabinet.
- Fixed front file drawers, top drawer front 11.2" (interior 10.6") bottom drawer front 13.6" (interior 12.5").
- Locking.
- Side to side hanging bars included.
- To add counterweight (W2 option), add \$200 list.

PRODUCT CODE	PRICE	SIZE/INCHES			WEIGHT LBS	VOL FT ³
		H	W	D		
BSLF20G1830C	1268	28	30	18	98.7	10.5
BSLF20G1836C	1327	28	36	18	114.4	12.5
BSLF20G1842C	1399	28	42	18	129.4	14.5

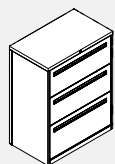
BSLF30G18xxC • Prime 3 High Lateral File

- Three high lateral filing cabinet.
- Fixed front file drawers, top & middle drawer front 11.2" (interior 10.6") bottom drawer front 13.6" (interior 12.5").
- Locking.
- Side to side hanging bars included.
- Will not line up with 42" high panels.
- To add counterweight (W2 option), add \$200 list.

PRODUCT CODE	PRICE	SIZE/INCHES			WEIGHT LBS	VOL FT ³
		H	W	D		
BSLF30G1830C	1662	39.2	30	18	127.9	14.5
BSLF30G1836C	1749	39.2	36	18	147.6	17.2
BSLF30G1842C	1849	39.2	42	18	167.5	20.0

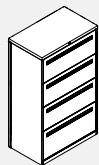
BSLF40H18xxC • Prime 4 High FFFF Lateral File

- Four high fixed front lateral filing cabinet.
- Fixed front file drawers, top drawer front 10.4" (interior 9.8") , second and third drawers 11.2" (interior 10.6") bottom drawer front 13.6" (interior 12.5").
- Locking.
- Side to side hanging bars included.
- To add counterweight (W2 option), add \$200 list.

PRODUCT CODE	PRICE	SIZE/INCHES			WEIGHT LBS	VOL FT ³
		H	W	D		
BSLF40G1830C	1950	49.6	30	18	159.1	18.2
BSLF40G1836C	2052	49.6	36	18	183.4	21.6
BSLF40G1842C	2176	49.6	42	18	208.5	25.1

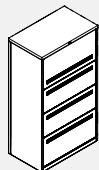
BSLF40H18xxC • Prime 4 High RFFF Lateral File

- Four high receding top door and remaining fixed front lateral filing cabinet.
- Top opening receding door + roll-out shelf 14.4" front, accepts binder height; fixed front drawers second and third drawers 11.2" (interior 10.6") bottom drawer front 13.6" (interior 12.5").
- Locking.
- Side to side hanging bars included.
- To add counterweight (W2 option), add \$200 list.

PRODUCT CODE	PRICE	SIZE/INCHES			WEIGHT LBS	VOL FT ³
		H	W	D		
BSLF40H1830C	2112	53.6	30	18	171.9	19.6
BSLF40H1836C	2226	53.6	36	18	198.2	23.3
BSLF40H1842C	2352	53.6	42	18	225.3	27.0

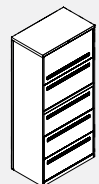
BSLF50P18xxC • Prime 5 High RFFFF Lateral File

- Five high receding top door and remaining fixed front lateral filing cabinet.
- Locking.
- Side to side hanging bars included.
- Top opening receding door + roll-out shelf 14.4" front, accepts binder height; fixed front drawers below - second and third 11.2" (interior 10.6") bottom drawer front 13.6" (interior 12.5").
- To add counterweight (W2 option), add \$200 list.

PRODUCT CODE	PRICE	SIZE/INCHES			WEIGHT LBS	VOL FT ³
		H	W	D		
BSLF50P1830C	2751	65.6	30	18	208.9	23.9
BSLF50P1836C	2896	65.6	36	18	239.9	28.4
BSLF50P1842C	3061	65.6	42	18	272.7	32.9

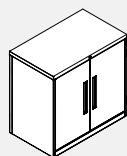
BSSC21G18xxC • Prime 2 High Storage Cabinet

- Two high storage cabinet.
- One adjustable shelf + fixed bottom shelf.
- Locking.

PRODUCT CODE	PRICE	SIZE/INCHES			WEIGHT LBS	VOL FT ³
		H	W	D		
BSSC21G1830C	1040	28	30	18	75.08	10.5
BSSC21G1836C	1161	28	36	18	86.48	12.5
BSSC21G1842C	1262	28	42	18	95.78	14.5

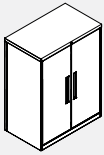
BSSC31G18xxC • Prime 3 High Storage Cabinet

- Three high storage cabinet.
- Two adjustable shelves + fixed bottom shelf.
- Will not line up to 42" high panels.
- Locking.

PRODUCT CODE	PRICE	SIZE/INCHES			WEIGHT LBS	VOL FT ³
		H	W	D		
BSSC31G1830C	1297	39.2	30	18	96.69	14.5
BSSC31G1836C	1459	39.2	36	18	111.59	17.2
BSSC31G1842C	1612	39.2	42	18	124.49	20.0

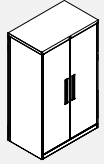
BSSC41G18xxC • Prime 4 High Storage Cabinet

- Three high storage cabinet to line up to 50" high panels.
- Three adjustable shelves + fixed bottom shelf.
- Locking.

PRODUCT CODE	PRICE	SIZE/INCHES			WEIGHT LBS	VOL FT ³
		H	W	D		
BSSC41G1830C	1502	49.6	30	18	111.22	18.2
BSSC41G1836C	1577	49.6	36	18	129.32	21.6
BSSC41G1842C	1832	49.6	42	18	145.42	25.1

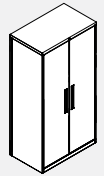
BSSC41H18xxC • Prime 4 High Storage Cabinet

- Four high storage cabinet.
- Three adjustable shelves + fixed bottom shelf.
- Locking.

PRODUCT CODE	PRICE	SIZE/INCHES			WEIGHT LBS	VOL FT ³
		H	W	D		
BSSC41H1830C	1551	53.6	30	18	120.17	19.6
BSSC41H1836C	1734	53.6	36	18	138.27	23.3
BSSC41H1842C	1920	53.6	42	18	154.37	27.0

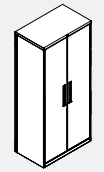
BSSC51C18xxC • Prime 5 High Storage Cabinet

- Five high storage cabinet.
- Four adjustable shelves + fixed bottom shelf.
- Locking.

PRODUCT CODE	PRICE	SIZE/INCHES			WEIGHT LBS	VOL FT ³
		H	W	D		
BSSC51C1830C	1751	65.6	30	18	138.5	23.9
BSSC51C1836C	1961	65.6	36	18	160.4	28.4
BSSC51C1842C	2176	65.6	42	18	180.4	32.9

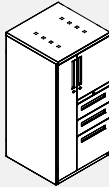
BSSLFxx24BCCL • Prime Tower, Left Wardrobe, Half Height Door, Box Box File Drawers

- Left wardrobe tower with half height door and box box file drawers.
- Wardrobe section includes top shelf and coat bar.
- Hinged door compartment of 50"h and 54"h includes one adjustable shelf; 66"h includes two adjustable open shelves.
- Wardrobe section includes top perforations for ventilation.
- Three locks included - wardrobe door, hinged door shelving compartment and drawers.
- To add counterweight (W2 option), add \$105 list.

PRODUCT CODE	PRICE	SIZE/INCHES			WEIGHT LBS	VOL FT ³
		H	W	D		
BSSLF4G24BCCL	2822	49.6	24	24	176.71	19.2
BSSLF4H24BCCL	2836	53.6	24	24	181.63	19.8
BSSLF5024BCCL	2968	65.6	24	24	204.52	25.2

*4G" Tower Shown

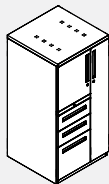
BSSLFxx24BCCR • Prime Tower, Right Wardrobe, Half Height Door, Box Box File Drawers

- Right wardrobe tower with half height door and box box file drawers.
- Wardrobe section includes top shelf and coat bar.
- Hinged door compartment of 50"h and 54"h includes one adjustable shelf; 66"h includes two adjustable open shelves.
- Wardrobe section includes top perforations for ventilation.
- Three locks included - wardrobe door, hinged door shelving compartment and drawers.
- To add counterweight (W2 option), add \$105 list.

PRODUCT CODE	PRICE	SIZE/INCHES			WEIGHT LBS	VOL FT ³
		H	W	D		
BSSLF4G24BCCR	2822	49.6	24	24	176.71	19.2
BSSLF4H24BCCR	2836	53.6	24	24	181.63	19.8
BSSLF5024BCCR	2968	65.6	24	24	204.52	25.2

*4G" Tower Shown

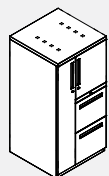
BSSLFxx24FCCL • Prime Tower, Left Wardrobe, Half Height Door, File File Drawers

- Left wardrobe tower with half height door and file file drawers.
- Wardrobe section includes top shelf and coat bar.
- Hinged door compartment of 50"h and 54"h includes one adjustable shelf; 66"h includes two adjustable open shelves.
- Wardrobe section includes top perforations for ventilation.
- Three locks included - wardrobe door, hinged door shelving compartment and drawers.
- To add counterweight (W2 option), add \$105 list.

PRODUCT CODE	PRICE	SIZE/INCHES			WEIGHT LBS	VOL FT ³
		H	W	D		
BSSLF4G24FCCL	2822	49.6	24	24	181.05	19.2
BSSLF4H24FCCL	2836	53.6	24	24	186.43	19.8
BSSLF5024FCCL	2968	65.6	24	24	231.53	25.2

*4G" Tower Shown

BSSLFxx24FCCR • Prime Tower, Right Wardrobe, Half Height Door, File File Drawers

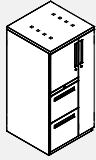

"4G" Tower Shown

- Right wardrobe tower with half height door and file file drawers.
- Wardrobe section includes top shelf and coat bar.
- Hinged door compartment of 50"h and 54"h includes one adjustable shelf; 66"h includes two adjustable open shelves.
- Wardrobe section includes top perforations for ventilation.
- Three locks included - wardrobe door, hinged door shelving compartment and drawers.
- To add counterweight (W2 option), add \$105 list.

PRODUCT CODE	PRICE	SIZE/INCHES			WEIGHT LBS	VOL FT ³
		H	W	D		
BSSLF4G24FCCR	2822	49.6	24	24	181.05	19.2
BSSLF4H24FCCR	2836	53.6	24	24	186.43	19.8
BSSLF5024FCCR	2968	65.6	24	24	231.53	25.2

BSSLSxx2424BOCL • Prime Tower, Left Wardrobe, Side Open Shelf, Box Box File Drawers

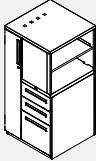

"4G" Tower Shown

- Left wardrobe tower with side open shelving and box box file drawers.
- Wardrobe section includes top shelf and coat bar.
- 50"h and 54"h include open side shelf with one adjustable shelf; 66"h includes open side shelf with two adjustable shelves.
- Wardrobe section includes top perforations for ventilation.
- Two locks included - wardrobe door and drawers.

PRODUCT CODE	PRICE	SIZE/INCHES			WEIGHT LBS	VOL FT ³
		H	W	D		
BSSLS4G2424BOCL	3117	49.6	24	24	186.18	19.2
BSSLS4H2424BOCL	3135	53.6	24	24	186.91	19.8
BSSLS502424BOCL	3131	65.6	24	24	236.34	25.2

BSSLSxx2424BOCR • Prime Tower, Right Wardrobe, Side Open Shelf, Box Box File Drawers

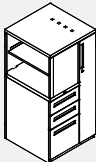

"4G" Tower Shown

- Right wardrobe tower with side open shelving and box box file drawers.
- Wardrobe section includes top shelf and coat bar.
- 50"h and 54"h include open side shelf with one adjustable shelf; 66"h includes open side shelf with two adjustable shelves.
- Wardrobe section includes top perforations for ventilation.
- Two locks included - wardrobe door and drawers.

PRODUCT CODE	PRICE	SIZE/INCHES			WEIGHT LBS	VOL FT ³
		H	W	D		
BSSLS4G2424BOCR	3117	49.6	24	24	186.18	19.2
BSSLS4H2424BOCR	3135	53.6	24	24	186.91	19.8
BSSLS502424BOCR	3131	65.6	24	24	236.34	25.2

BSSLSxx2424FOCL • Prime Tower, Left Wardrobe, Side Open Shelf, File File Drawers

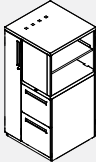

"4G" Tower Shown

- Left wardrobe tower with side open shelving and file file drawers.
- Wardrobe section includes top shelf and coat bar.
- 50"h and 54"h include open side shelf with one adjustable shelf; 66"h includes open side shelf with two adjustable shelves.
- Wardrobe section includes top perforations for ventilation.
- Two locks included - wardrobe door and drawers.

PRODUCT CODE	PRICE	SIZE/INCHES			WEIGHT LBS	VOL FT ³
		H	W	D		
BSSLS4G2424FOCL	3117	49.6	24	24	179.54	19.2
BSSLS4H2424FOCL	3135	53.6	24	24	180.26	19.8
BSSLS502424FOCL	3131	65.6	24	24	232.55	25.2

BSSLSxx2424FOCR • Prime Tower, Right Wardrobe, Side Open Shelf, File File Drawers

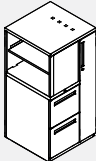

"4G" Tower Shown

- Right wardrobe tower with side open shelving and file file drawers.
- Wardrobe section includes top shelf and coat bar.
- 50"h and 54"h include open side shelf with one adjustable shelf; 66"h includes open side shelf with two adjustable shelves.
- Wardrobe section includes top perforations for ventilation.
- Two locks included - wardrobe door and drawers.

PRODUCT CODE	PRICE	SIZE/INCHES			WEIGHT LBS	VOL FT ³
		H	W	D		
BSSLS4G2424FOCR	3117	49.6	24	24	179.54	19.2
BSSLS4H2424FOCR	3135	53.6	24	24	180.26	19.8
BSSLS502424FOCR	3131	65.6	24	24	232.55	25.2

BSWC51C18xxC • Prime Wardrobe

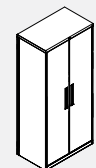

- Wardrobe cabinet.
- 30"w includes full width shelf and side to side coat rod.
- 36" and 42"W are split with shelving on left side, wardrobe on the other.
- Locking.

PRODUCT CODE	PRICE	SIZE/INCHES			WEIGHT LBS	VOL FT ³
		H	W	D		
BSWC51C1830C	1789	65.6	30	18	125.26	23.8
BSWC51C1836C	1998	65.6	36	18	164.97	28.4
BSWC51C1842C	2198	65.6	42	18	180.59	32.9

BSCC31G18xxC • Prime Three High Combination Cabinet

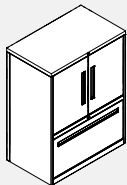

- Multi stor cabinet including hinged door upper section with one adjustable shelf; one fixed front file drawers below.
- Will not line up to 42" high panels.
- Locking.

PRODUCT CODE	PRICE	SIZE/INCHES			WEIGHT LBS	VOL FT ³
		H	W	D		
BSCC31G1830C	2227	39.2	30	18	117.3	14.5
BSCC31G1836C	2426	39.2	36	18	135.5	17.2
BSCC31G1842C	2635	39.2	42	18	152.5	20.0

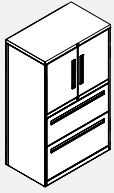
BSCC41G18xxC • Prime Four High Combination Cabinet

- Multi stor cabinet including hinged door upper section with one adjustable shelf; two fixed front file drawers below, lines up to 50" high panels.
- Locking.
- To add counterweight (W2 option), add \$200 list.

PRODUCT CODE	PRICE	SIZE/INCHES			WEIGHT LBS	VOL FT ³
		H	W	D		
BSCC41G1830C	2665	49.6	30	18	149.96	18.2
BSCC41G1836C	2853	49.6	36	18	172.96	21.6
BSCC41G1842C	3072	49.6	42	18	195.36	25.1

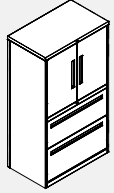
BSCC41H18xxC • Prime Four High Combination Cabinet

- Multi stor cabinet including hinged door upper section with one adjustable shelf; two fixed front file drawers below, lines up to 54" high panels.
- Locking.
- To add counterweight (W2 option), add \$200 list.

PRODUCT CODE	PRICE	SIZE/INCHES			WEIGHT LBS	VOL FT ³
		H	W	D		
BSCC41H1830C	2796	53.6	30	18	154.54	19.6
BSCC41H1836C	2992	53.6	36	18	178.54	23.3
BSCC41H1842C	3225	53.6	42	18	202.04	27.0

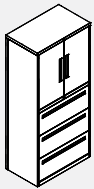
BSCC31C18xxC • Prime Five High Combination Cabinet

- Multi stor cabinet including hinged door upper section with one adjustable shelf; three fixed front file drawers below.
- Locking.
- To add counterweight (W2 option), add \$200 list.

PRODUCT CODE	PRICE	SIZE/INCHES			WEIGHT LBS	VOL FT ³
		H	W	D		
BSCC51C1830C	3083	65.6	30	18	188.5	23.9
BSCC51C1836C	3344	65.6	36	18	216.9	28.4
BSCC51C1842C	3581	65.6	42	18	245.5	32.9

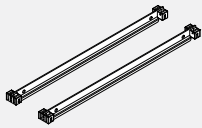
BSLFA0718 • Prime Front to Back File Bars

- Package of two, grey finish.

PRODUCT CODE	PRICE	SIZE/INCHES			WEIGHT LBS	VOL FT ³
		H	W	D		
BSLFA0718	28	1	17.3	1	1	0.04

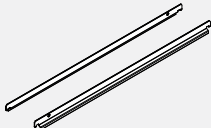
BSLFS • Prime Hanging File Bars

- Package of two, grey finish.

PRODUCT CODE	PRICE	SIZE/INCHES			WEIGHT LBS	VOL FT ³
		H	W	D		
BSLFA01	48	1.3	27.5	0.5	2	0.03
BSLFA02	48	1.3	33.5	0.5	2.4	0.04
BSLFA03	48	1.3	39.5	0.5	2.8	0.05

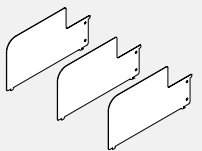
BSLFA1018 • Prime Plate Dividers

- Package of three, grey finish.

PRODUCT CODE	PRICE	SIZE/INCHES			WEIGHT LBS	VOL FT ³
		H	W	D		
BSLFA1018	61	7.25	13.5	0.2	4	0.07

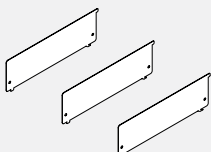
BSLFA2418 • Prime Half Height Plate Dividers

- Package of three, grey finish.

PRODUCT CODE	PRICE	SIZE/INCHES			WEIGHT LBS	VOL FT ³
		H	W	D		
BSLFA2418	45	3.95	13.5	0.2	2.2	0.04

BSLFA2018 • Prime EDP Adapters

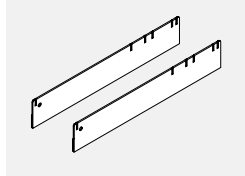

PRODUCT CODE	PRICE	SIZE/INCHES			WEIGHT LBS	VOL FT³
		H	W	D		
BSLFA2018	51	2.6	16.5	0.15	2.5	0.02

BSK • Keys and Replacement Lock Core

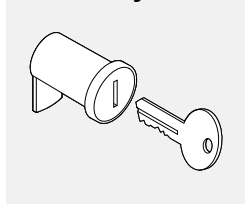

- Set of Extra Keys.
- Replacement Lock and Key.

PRODUCT CODE	PRICE	SIZE/INCHES			WEIGHT LBS	VOL FT³
		H	W	D		
BSKY EXTRA KEY	14	1.75	0.75	0.2	0.2	0.01
BSKC LOCK & KEY	41	2	1	0.5	0.4	0.01

BSSA • Prime Extra Cabinet Shelves

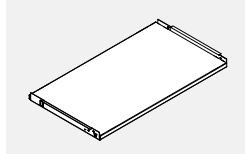

- Shelf, non-slotted.

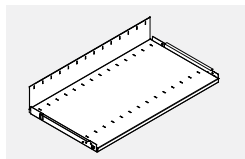

- Shelf, slotted.

PRODUCT CODE	PRICE	SIZE/INCHES			WEIGHT LBS	VOL FT³
		H	W	D		
Shelf, non-slotted.						
BSSA011830	141	0.8	28.4	16	7.2	1.8
BSSA011836	147	0.8	34.4	16	8.4	2.2
BSSA011842	155	0.8	40.4	16	9.5	2.6
Shelf, slotted.						
BSSA021830	154	5.25	28.4	16	8.2	1.8
BSSA021836	160	5.25	34.4	16	9.6	2.2
BSSA021842	176	5.25	40.4	16	10.8	2.6

Diet Panel System

Diet represents an innovative tool for creating an economical, efficient work space, accommodating various tasks. From 42" high panels which provide an open office feel to 50" and 54" high panels, for seated privacy and 66" high panels for standing privacy, Diet effectively supports the creation of various work environments. Diet is simple, easy to comprehend, easy to specify and install, with a minimum of add-on and dedicated/handed components to maximize reconfiguration flexibility. All Diet panels ship with a set of self-leveling connectors that accommodate any angle, but also straight, 90°, three-way T and 120° configurations, as well as four-way "X". Truly universal connectors support the above panel configurations regardless of panel heights. Such a configuration and height independent connecting method eliminates the need to order additional components during future office reconfigurations. Diet is an economical, "soft wire" system with simple means of optional power and data/communication cable management trough that snaps to the bottom of the panel.

With the exception of panels with open area below the mid rail, all Diet panels are built with 6" clearance opening between the floor and the bottom rail. This feature not only serves as a simple passage for cables between back-to-back stations and an interface for a snap on cable trough, but it mainly provides ultimate flexibility of panel station placement even if one panel needs to be located right above a floor monument. Diet's slim appearance, sophisticated industrial design, detailing and advanced engineering communicate high perceived value, exceeding expectations usually related to budget products. Diet can be specified on its own, with integrated worksurface, storage and accessory support, privacy and space organization in free standing office environments. Whether combined with Boulevard system, or raised floors, Diet, as a tool, bridges mobile or stationary freestanding furniture with power/data delivery solutions, that are hard wired to a building power supply.

Technical Information

Panels

- Panels are 1.3" thick.
- Width ranges from 24" to 60" at 6" increments.
- Heights include 42", 50", 54" and 66" (nominal).
- Extruded aluminum frame surrounds a fabric wrapped interior with a 7/8" particle board frame, sandwiched between 2 pieces of 1/8" masonite.
- Panel frame finish is durable epoxy powder coated.
- Finished panel includes top, corner and end caps.
- For glazing - Smoke development index 500.
- For tempered glass, add "TG" to the end of the product code and add 20% to the price regardless of fabric grade.
- Top rail accepts Global Contract accessories, monitor arm supports, off-module shelves, and task light brackets.
- Top rail on Glazed Top Panels is not intended for use with panel mounted shelves and panel mounted overhead.
- Middle rail accepts bracket for off-module worksurface support, Global Contract accessories, off-module shelves and power bar.
- Bottom rail accepts brackets for off-module worksurface support, Global Contract accessories, off-module shelves and optional cable manager and power bar.

- Optional PVC cable manager friction fits into bottom rail.
- Two leveler are included with a 1.75" leveling range.
- Vertical frame members have integrated grooves for additional components.
- Charcoal covers are provided at front of vertical members where connectors attach.
- Panels include 3 sets of hinge connectors, 1 set of spacers and 6 pins.
- Connecting method is simple, accommodating typical configuration, as well as connection of panels at any angle, regardless of height.

Panel Options

- Laminate or whiteboard may be substituted for fabric on panels only, see "OPT" column.
 - Tackboard panels available, please add 25% upcharge.
 - Steel facing available, contact your customer service representative.
- Note:
- 42" High Diet panels do not match Boulevard 42"
 - 50" High Diet panels match Boulevard 50"
 - 54" High Diet panels do not match standard Boulevard 54"
 - 66" High Diet panels matches Boulevard 66"
 - To order 42" and 54" high Diet panels to match Boulevard, please order "BDPFF" and "BDPOF".

HOW DIET REDUCES YOUR COSTS

Finished Panel:

- No inventory costs for connectors, top caps, kick plates and clips.
- Less time required to install, or to disassemble, move and re-install.
- Open bottom panels can reduce cost and improve circulation within the office.

Fewer Parts:

- Only 1 universal cantilever and 3 brackets are needed to build most workstations.
- Easy to attach and remove components from panels.

Simplified Specifications:

- Fewer parts and components make specifying, ordering, and verifying less work.
- Product fits a 6" planning module.

Communications Channel:

- Base communication channel reduces time to install and change cables.

Warranty:

- Limited Lifetime Warranty on materials and workmanship.

DIET PANELS - GUIDELINES FOR ORDERING PRODUCT

Codes

The product guide uses a numbering system with meaningful alphanumeric characters to create a simple-to-understand product number. This makes specifying the product much easier and more accurate.

Example of Panel: **DPFRF6636 CHR**

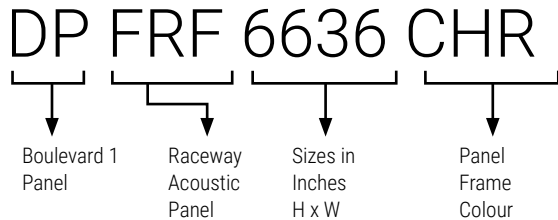

How to Specify

- Specify Diet Panel type and size by code.
- Specify panel frame finish - ie. CHR (Charcoal).
- Specify all six panel fabric options if necessary.

AN50	Inside Lower Fabric
AN50	Inside Middle Fabric
AN50	Inside Upper Fabric
BE21	Outside Lower Fabric
BE21	Outside Middle Fabric
BE21	Outside Upper Fabric

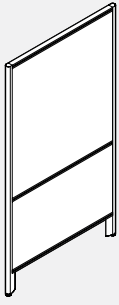
DPFF • Fabric Bottom and Fabric Top Panel

- Fabric above and below the middle rail provides visual privacy.
- Full panel with top, middle and bottom rail.
- OPT* = Laminate or Whiteboard.
- DPFF Panels do not match standard Boulevard heights of 42" and 54".
- DPFF Panels of 50" and 66" height will match standard Boulevard panel heights.

PRODUCT CODE	PRICE			SIZE/ H	INCHES			WEIGHT VOL	
	GR1	GR2	OPT*		W	D	LBS	FT ³	
DPFF4224	388	434	485	42	24	1.3	16	1.32	
DPFF4230	409	455	508	42	30	1.3	19	1.62	
DPFF4236	433	517	609	42	36	1.3	23	1.94	
DPFF4242	455	541	631	42	42	1.3	27	2.24	
DPFF4248	480	565	656	42	48	1.3	31	2.55	
DPFF4254	503	586	680	42	54	1.3	35	2.85	
DPFF4260	523	609	699	42	60	1.3	39	3.16	
DPFF5024	484	534	581	50	24	1.3	16	1.62	
DPFF5030	510	555	608	50	30	1.3	21	2.08	
DPFF5036	537	649	770	50	36	1.3	25	2.47	
DPFF5042	562	673	794	50	42	1.3	30	2.85	
DPFF5048	590	701	824	50	48	1.3	35	3.25	
DPFF5054	614	726	850	50	54	1.3	40	3.63	
DPFF5060	641	754	874	50	60	1.3	45	4.02	
DPFF5424	484	534	581	54	24	1.3	18	1.62	
DPFF5430	510	555	608	54	30	1.3	23	2.08	
DPFF5436	537	649	770	54	36	1.3	27	2.47	
DPFF5442	562	673	794	54	42	1.3	32	2.85	
DPFF5448	590	701	824	54	48	1.3	37	3.25	
DPFF5454	614	726	850	54	54	1.3	42	3.63	
DPFF5460	641	754	874	54	60	1.3	47	4.02	
DPFF6624	527	604	683	66	24	1.3	23	2.04	
DPFF6630	557	633	714	66	30	1.3	29	2.52	
DPFF6636	589	699	823	66	36	1.3	35	3.00	
DPFF6642	619	731	852	66	42	1.3	41	3.46	
DPFF6648	645	758	880	66	48	1.3	47	3.93	
DPFF6654	672	785	907	66	54	1.3	53	4.40	
DPFF6660	699	814	935	66	60	1.3	59	4.90	

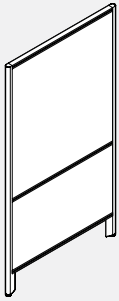
BDPFF • Fabric Bottom and Fabric Top Panel to Match Boulevard Panels

- Fabric above and below the middle rail provides visual privacy.
- Full panel with top, middle and bottom rail.
- OPT* = Laminate or Whiteboard
- Panels will match corresponding Boulevard Panel heights.

PRODUCT CODE	PRICE			SIZE/ H	INCHES			WEIGHT VOL	
	GR1	GR2	OPT*		W	D	LBS	FT ³	
BDPFF4224	388	434	485	42	24	1.3	16	1.32	
BDPFF4230	409	455	508	42	30	1.3	19	1.62	
BDPFF4236	433	517	609	42	36	1.3	23	1.94	
BDPFF4242	455	541	631	42	42	1.3	27	2.24	
BDPFF4248	480	565	656	42	48	1.3	31	2.55	
BDPFF4254	503	586	680	42	54	1.3	35	2.85	
BDPFF4260	523	609	699	42	60	1.3	39	3.16	
BDPFF5424	484	534	581	54	24	1.3	18	1.62	
BDPFF5430	510	555	608	54	30	1.3	23	2.08	
BDPFF5436	537	649	770	54	36	1.3	27	2.47	
BDPFF5442	562	673	794	54	42	1.3	32	2.85	
BDPFF5448	590	701	824	54	48	1.3	37	3.25	
BDPFF5454	614	726	850	54	54	1.3	42	3.63	
BDPFF5460	641	754	874	54	60	1.3	47	4.02	

DPOF • Open Bottom and Fabric Top Panel

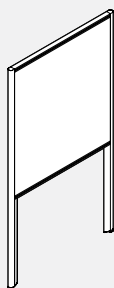

- Fabric above the middle rail provides visual privacy.
- Panel with top and middle rail only.
- Open bottom reduces cost and improves air circulation within the office.
- OPT* = Laminate or Whiteboard.
- DPOF Panels do not match standard Boulevard heights of 42" and 54".
- DPOF Panels of 50" and 66" height will match standard Boulevard panel heights.

PRODUCT CODE	PRICE			SIZE/ H	INCHES			WEIGHT VOL	
	GR1	GR2	OPT*		W	D	LBS	FT³	
DPOF4224	253	268	283	42	24	1.3	9	1.32	
DPOF4230	271	284	301	42	30	1.3	12	1.62	
DPOF4236	313	342	372	42	36	1.3	15	1.94	
DPOF4242	328	354	385	42	42	1.3	17	2.24	
DPOF4248	343	372	404	42	48	1.3	19	2.55	
DPOF4254	361	388	418	42	54	1.3	22	2.85	
DPOF4260	373	404	433	42	60	1.3	24	3.16	
DPOF5024	319	349	378	50	24	1.3	10	1.62	
DPOF5030	340	369	398	50	30	1.3	13	2.08	
DPOF5036	406	462	522	50	36	1.3	16	2.47	
DPOF5042	425	483	543	50	42	1.3	19	2.85	
DPOF5048	446	503	563	50	48	1.3	21	3.25	
DPOF5054	464	521	581	50	54	1.3	25	3.63	
DPOF5060	484	542	603	50	60	1.3	28	4.02	
DPOF5424	319	349	378	54	24	1.3	12	1.62	
DPOF5430	340	369	398	54	30	1.3	15	2.08	
DPOF5436	406	462	522	54	36	1.3	18	2.47	
DPOF5442	425	483	543	54	42	1.3	21	2.85	
DPOF5448	446	503	563	54	48	1.3	24	3.25	
DPOF5454	464	521	581	54	54	1.3	27	3.63	
DPOF5460	484	542	603	54	60	1.3	30	4.02	
DPOF6624	389	448	508	66	24	1.3	17	2.04	
DPOF6630	412	472	534	66	30	1.3	21	2.52	
DPOF6636	485	543	604	66	36	1.3	25	3.00	
DPOF6642	536	591	653	66	42	1.3	29	3.46	
DPOF6648	561	615	678	66	48	1.3	33	3.93	
DPOF6654	582	641	699	66	54	1.3	37	4.40	
DPOF6660	607	661	723	66	60	1.3	41	4.90	

BDPOF • Open Bottom and Fabric Top Panel to Match Boulevard Panels

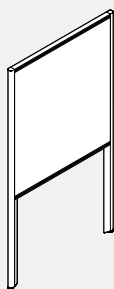

- Fabric above the middle rail provides visual privacy.
- Panel with top and middle rail only.
- Open bottom reduces cost and improves air circulation within the office.
- OPT* = Laminate or Whiteboard
- Panels will match corresponding Boulevard Panel heights.

PRODUCT CODE	PRICE			SIZE/ H	INCHES			WEIGHT VOL	
	GR1	GR2	OPT*		W	D	LBS	FT³	
BDPOF4224	253	268	283	42	24	1.3	9	1.32	
BDPOF4230	271	284	301	42	30	1.3	12	1.62	
BDPOF4236	313	342	372	42	36	1.3	15	1.94	
BDPOF4242	328	354	385	42	42	1.3	17	2.24	
BDPOF4248	343	372	404	42	48	1.3	19	2.55	
BDPOF4254	361	388	418	42	54	1.3	22	2.85	
BDPOF4260	373	404	433	42	60	1.3	24	3.16	
BDPOF5424	319	349	378	54	24	1.3	12	1.62	
BDPOF5430	340	369	398	54	30	1.3	15	2.08	
BDPOF5436	406	462	522	54	36	1.3	18	2.47	
BDPOF5442	425	483	543	54	42	1.3	21	2.85	
BDPOF5448	446	503	563	54	48	1.3	24	3.25	
BDPOF5454	464	521	581	54	54	1.3	27	3.63	
BDPOF5460	484	542	603	54	60	1.3	30	4.02	

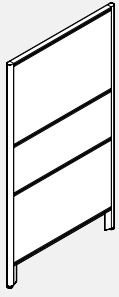
DPFRF • Fabric Bottom, Middle and Top Panel

- Fabric above, below and between the middle rails provides visual privacy.
- Full panel with additional rail at 42" high.
- Upper middle rail accepts Global Contract Accessories, Monitor Arm Support and Off-Module Shelves.
- OPT* = Laminate or Whiteboard

PRODUCT CODE	PRICE			SIZE/ H	INCHES			WEIGHT VOL	
	GR1	GR2	OPT*		W	D	LBS	FT ³	
DPFRF5024	509	553	607	50	24	1.3	16	1.62	
DPFRF5030	537	569	604	50	30	1.3	21	2.08	
DPFRF5036	563	621	681	50	36	1.3	25	2.47	
DPFRF5042	591	658	731	50	42	1.3	30	2.85	
DPFRF5048	621	705	796	50	48	1.3	35	3.25	
DPFRF5054	645	727	823	50	54	1.3	40	3.63	
DPFRF5060	672	774	879	50	60	1.3	45	4.02	
DPFRF5424	509	553	607	54	24	1.3	18	1.62	
DPFRF5430	537	569	604	54	30	1.3	23	2.08	
DPFRF5436	563	621	681	54	36	1.3	27	2.47	
DPFRF5442	591	658	731	54	42	1.3	32	2.85	
DPFRF5448	621	705	796	54	48	1.3	37	3.25	
DPFRF5454	645	727	823	54	54	1.3	42	3.63	
DPFRF5460	672	757	850	54	60	1.3	47	4.02	
DPFRF6624	553	607	659	66	24	1.3	23	2.04	
DPFRF6630	586	638	692	66	30	1.3	29	2.52	
DPFRF6636	619	701	794	66	36	1.3	35	3.00	
DPFRF6642	652	747	850	66	42	1.3	41	3.46	
DPFRF6648	678	775	877	66	48	1.3	47	3.93	
DPFRF6654	707	809	917	66	54	1.3	53	4.40	
DPFRF6660	736	879	1028	66	60	1.3	59	4.90	

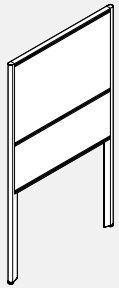
DPORF • Open Bottom Fabric Middle and Top Panel

- Fabric above the middle rail provides visual privacy.
- Open bottom panel with additional rail at 42" high.
- Upper middle rail accepts Global Contract Accessories, Monitor Arm Support and Off-Module Shelves.
- Open bottom reduces cost and improves air circulation within the office.
- OPT* = Laminate or Whiteboard

PRODUCT CODE	PRICE			SIZE/ H	INCHES			WEIGHT VOL	
	GR1	GR2	OPT*		W	D	LBS	FT ³	
DPORF5024	336	369	404	50	24	1.3	10	1.62	
DPORF5030	354	389	422	50	30	1.3	13	2.08	
DPORF5036	425	459	495	50	36	1.3	16	2.47	
DPORF5042	446	488	540	50	42	1.3	19	2.85	
DPORF5048	469	513	562	50	48	1.3	21	3.25	
DPORF5054	486	535	580	50	54	1.3	25	3.63	
DPORF5060	509	561	613	50	60	1.3	28	4.02	
DPORF5424	336	369	404	54	24	1.3	12	1.62	
DPORF5430	354	389	422	54	30	1.3	15	2.08	
DPORF5436	425	459	495	54	36	1.3	18	2.47	
DPORF5442	446	488	540	54	42	1.3	21	2.85	
DPORF5448	469	513	562	54	48	1.3	24	3.25	
DPORF5454	486	540	592	54	54	1.3	27	3.63	
DPORF5460	509	561	613	54	60	1.3	30	4.02	
DPORF6624	409	454	503	66	24	1.3	17	2.04	
DPORF6630	434	480	527	66	30	1.3	21	2.52	
DPORF6636	512	584	661	66	36	1.3	25	3.00	
DPORF6642	562	641	724	66	42	1.3	29	3.46	
DPORF6648	589	660	741	66	48	1.3	33	3.93	
DPORF6654	612	692	778	66	54	1.3	37	4.40	
DPORF6660	636	712	788	66	60	1.3	41	4.90	

DPFFG • Fabric Bottom, Middle and Glazed Top Panel

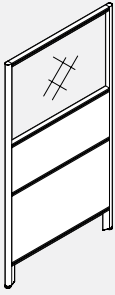

- Fabric below and between the middle rails provides visual privacy.
- Fabric bottom panel with additional rail at 28" high.
- Upper middle rail accepts Global Contract Accessories, Monitor Arm Support and Off-Module Shelves.
- Extruded aluminum frame surrounds acrylic glazing at top.
- PVC Extrusion is only Charcoal.
- For tempered glass, add "TG" to the end of the product code and add 20% to the price regardless of fabric grade.
- OPT* = Laminate or Whiteboard

PRODUCT CODE	PRICE			SIZE/ H	INCHES			WEIGHT VOL	
	GR1	GR2	OPT*		W	D	LBS	FT ³	
DPFFG5024	513	546	580	50	24	1.3	12	1.62	
DPFFG5030	562	593	629	50	30	1.3	15	2.08	
DPFFG5036	610	682	757	50	36	1.3	18	2.47	
DPFFG5042	659	731	806	50	42	1.3	21	2.85	
DPFFG5048	709	779	853	50	48	1.3	24	3.25	
DPFFG5054	759	830	907	50	54	1.3	27	3.63	
DPFFG5060	824	892	963	50	60	1.3	30	4.02	
DPFFG5424	513	546	580	54	24	1.3	17	1.62	
DPFFG5430	562	593	629	54	30	1.3	21	2.08	
DPFFG5436	610	682	757	54	36	1.3	25	2.47	
DPFFG5442	659	731	806	54	42	1.3	29	2.85	
DPFFG5448	709	779	853	54	48	1.3	33	3.25	
DPFFG5454	759	830	907	54	54	1.3	37	3.63	
DPFFG5460	824	894	970	54	60	1.3	41	4.02	
DPFFG6624	608	665	724	66	24	1.3	20	2.04	
DPFFG6630	673	731	791	66	30	1.3	25	2.52	
DPFFG6636	741	814	893	66	36	1.3	30	3.00	
DPFFG6642	809	883	960	66	42	1.3	35	3.46	
DPFFG6648	877	951	1028	66	48	1.3	40	3.93	
DPFFG6654	942	1017	1094	66	54	1.3	45	4.40	
DPFFG6660	1024	1108	1200	66	60	1.3	50	4.90	

DPOFG • Open Bottom, Middle Fabric and Glazed Top Panel

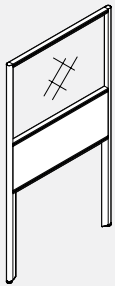

- Fabric between the middle rails.
- Open bottom panel with additional rail at 42" high.
- Upper middle rail accepts Global Contract Accessories, Monitor Arm Support and Off-Module Shelves.
- Extruded aluminum frame surrounds acrylic glazing at top.
- PVC Extrusion is only Charcoal.
- For tempered glass, add "TG" to the end of the product code and add 20% to the price regardless of fabric grade.
- OPT* = Laminate or Whiteboard

PRODUCT CODE	PRICE			SIZE/ H	INCHES			WEIGHT VOL	
	GR1	GR2	OPT*		W	D	LBS	FT ³	
DPOFG5024	405	418	433	50	24	1.3	14	1.62	
DPOFG5030	442	455	472	50	30	1.3	17	2.08	
DPOFG5036	478	490	508	50	36	1.3	20	2.47	
DPOFG5042	517	534	546	50	42	1.3	24	2.85	
DPOFG5048	553	569	582	50	48	1.3	27	3.25	
DPOFG5054	592	622	653	50	54	1.3	30	3.63	
DPOFG5060	636	665	694	50	60	1.3	34	4.02	
DPOFG5424	405	418	433	54	24	1.3	14	1.62	
DPOFG5430	442	455	472	54	30	1.3	17	2.08	
DPOFG5436	478	490	508	54	36	1.3	20	2.47	
DPOFG5442	517	534	546	54	42	1.3	24	2.85	
DPOFG5448	553	569	582	54	48	1.3	27	3.25	
DPOFG5454	592	622	653	54	54	1.3	30	3.63	
DPOFG5460	636	665	694	54	60	1.3	34	4.02	
DPOFG6624	505	517	535	66	24	1.3	17	2.04	
DPOFG6630	561	574	589	66	30	1.3	21	2.52	
DPOFG6636	619	647	678	66	36	1.3	25	3.00	
DPOFG6642	659	689	720	66	42	1.3	29	3.46	
DPOFG6648	718	747	778	66	48	1.3	33	3.93	
DPOFG6654	773	800	829	66	54	1.3	37	4.40	
DPOFG6660	833	863	893	66	60	1.3	41	4.90	

DPFG • Fabric Bottom and Glazed Top Panel

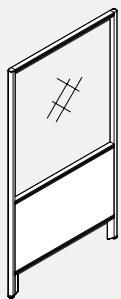

- **Fabric between the middle rails.**
- Open bottom panel with additional rail at 42" high.
- Upper middle rail accepts Global Contract Accessories, Monitor Arm Support and Off-Module Shelves.
- Open bottom reduces cost and improves air circulation within the office.
- Extruded aluminum frame surrounds acrylic glazing at top.
- PVC Extrusion is only Charcoal.
- For tempered glass, add "TG" to the end of the product code and add 20% to the price regardless of fabric grade.
- OPT* = Laminate or Whiteboard

PRODUCT CODE	PRICE			SIZE/ INCHES			WEIGHT VOL	
	GR1	GR2	OPT*	H	W	D	LBS	FT³
DPFG4224	555	575	595	42	24	1.3	11	1.32
DPFG4230	603	621	641	42	30	1.3	14	1.62
DPFG4236	655	672	693	42	36	1.3	16	1.94
DPFG4242	697	755	816	42	42	1.3	18	2.24
DPFG4248	746	802	863	42	48	1.3	21	2.55
DPFG4254	796	853	915	42	54	1.3	23	2.85
DPFG4260	842	897	959	42	60	1.3	26	3.16
DPFG5024	671	689	712	50	24	1.3	12	1.62
DPFG5030	724	745	763	50	30	1.3	15	2.08
DPFG5036	774	790	812	50	36	1.3	18	2.47
DPFG5042	826	884	943	50	42	1.3	21	2.85
DPFG5048	874	931	994	50	48	1.3	24	3.25
DPFG5054	926	984	1043	50	54	1.3	27	3.63
DPFG5060	976	1034	1094	50	60	1.3	29	4.02
DPFG5424	671	689	712	54	24	1.3	13	1.62
DPFG5430	724	745	763	54	30	1.3	16	2.08
DPFG5436	774	790	812	54	36	1.3	20	2.47
DPFG5442	826	884	943	54	42	1.3	23	2.85
DPFG5448	874	931	994	54	48	1.3	26	3.25
DPFG5454	926	984	1043	54	54	1.3	29	3.63
DPFG5460	976	1034	1094	54	60	1.3	32	4.02
DPFG6624	727	748	770	66	24	1.3	17	2.04
DPFG6630	784	802	824	66	30	1.3	21	2.52
DPFG6636	837	894	955	66	36	1.3	24	3.00
DPFG6642	892	949	1007	66	42	1.3	28	3.46
DPFG6648	943	1000	1062	66	48	1.3	32	3.93
DPFG6654	999	1057	1118	66	54	1.3	36	4.40
DPFG6660	1056	1113	1173	66	60	1.3	40	4.90

DPFS • Fabric Bottom Slat Top Panel

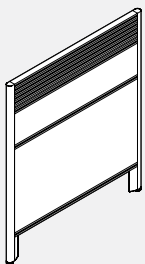

- **Integrated 6" slat rail provides flexibility of use.**
- Panel integrated slat rail accepts Global Contract Accessories, Monitor Arm Support, Off-Module Shelves, Task Light Bracket and Power Bar.
- OPT* = Laminate or Whiteboard

PRODUCT CODE	PRICE			SIZE/ INCHES			WEIGHT VOL	
	GR1	GR2	OPT*	H	W	D	LBS	FT³
DPFS4224	397	421	450	42	24	1.3	19	1.32
DPFS4230	484	510	539	42	30	1.3	23	1.62
DPFS4236	540	609	686	42	36	1.3	28	1.94
DPFS4242	589	658	734	42	42	1.3	33	2.24
DPFS4248	634	707	781	42	48	1.3	37	2.55
DPFS4254	687	757	831	42	54	1.3	42	2.85
DPFS4260	733	804	880	42	60	1.3	47	3.16

DPFSF • Fabric Bottom, Slat Middle and Fabric Top Panel

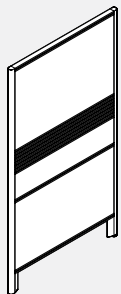

- **Integrated 6" slat rail between the middle rails provides flexibility of use. Fabric at the top provides visual privacy.**
- Panel integrated slat rail accepts Global Contract Accessories, Monitor Arm Support, Off-Module Shelves, Task Light Bracket and Power Bar.
- OPT* = Laminate or Whiteboard

PRODUCT CODE	PRICE			SIZE/ INCHES			WEIGHT VOL	
	GR1	GR2	OPT*	H	W	D	LBS	FT³
DPFSF5024	551	578	605	50	24	1.3	21	1.62
DPFSF5030	610	636	661	50	30	1.3	28	2.08
DPFSF5036	671	744	817	50	36	1.3	34	2.47
DPFSF5042	727	801	877	50	42	1.3	40	2.85
DPFSF5048	790	862	936	50	48	1.3	46	3.25
DPFSF5054	845	916	992	50	54	1.3	52	3.63
DPFSF5060	903	973	1051	50	60	1.3	58	4.02
DPFSF5424	551	578	605	54	24	1.3	23	1.62
DPFSF5430	610	636	661	54	30	1.3	30	2.08
DPFSF5436	671	744	817	54	36	1.3	36	2.47
DPFSF5442	727	801	877	54	42	1.3	42	2.85
DPFSF5448	790	862	936	54	48	1.3	48	3.25
DPFSF5454	845	916	992	54	54	1.3	54	3.63
DPFSF5460	903	973	1051	54	60	1.3	60	4.02
DPFSF6624	633	681	731	66	24	1.3	28	2.04
DPFSF6630	695	745	794	66	30	1.3	35	2.52
DPFSF6636	763	879	998	66	36	1.3	42	3.00
DPFSF6642	826	938	1061	66	42	1.3	49	3.46
DPFSF6648	888	1000	1122	66	48	1.3	56	3.93
DPFSF6654	951	1063	1182	66	54	1.3	63	4.40
DPFSF6660	1011	1123	1243	66	60	1.3	70	4.90

DPOSF • Open Bottom, Slat Middle Panel

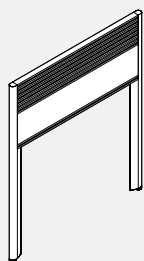

- Integrated 6" slat rail between the middle rails provides flexibility of use.
- Panel integrated slat rail accepts Global Contract Accessories, Monitor Arm Support, Off-Module Shelves, Task Light Bracket and Power Bar.
- OPT* = Laminate or Whiteboard

PRODUCT CODE	PRICE			SIZE/ INCHES			WEIGHT VOL	
	GR1	GR2	OPT*	H	W	D	LBS	FT ³
DPOSF4224	355	366	371	42	24	1.3	12	1.32
DPOSF4230	398	406	411	42	30	1.3	17	1.62
DPOSF4236	441	454	471	42	36	1.3	24	1.94
DPOSF4242	480	491	509	42	42	1.3	28	2.24
DPOSF4248	522	539	551	42	48	1.3	36	2.55
DPOSF4254	563	577	591	42	54	1.3	40	2.85
DPOSF4260	603	614	630	42	60	1.3	44	3.16

DPOSF • Open Bottom, Slat Middle and Fabric Top Panel

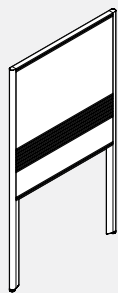

- Integrated 6" slat rail between the middle rails provides flexibility of use. Fabric above middle rail provides privacy.
- Panel integrated slat rail accepts Global Contract Accessories, Monitor Arm Support, Off-Module Shelves, Task Light Bracket and Power Bar.
- Open bottom reduces cost and improves air circulation within the office.
- OPT* = Laminate or Whiteboard

PRODUCT CODE	PRICE			SIZE/ INCHES			WEIGHT VOL	
	GR1	GR2	OPT*	H	W	D	LBS	FT ³
DPOSF5024	475	494	517	50	24	1.3	13	1.62
DPOSF5030	523	546	569	50	30	1.3	14	2.08
DPOSF5036	574	614	659	50	36	1.3	21	2.47
DPOSF5042	625	666	713	50	42	1.3	25	2.85
DPOSF5048	672	715	759	50	48	1.3	29	3.25
DPOSF5054	724	766	813	50	54	1.3	31	3.63
DPOSF5060	774	814	860	50	60	1.3	35	4.02
DPOSF5424	475	494	517	54	24	1.3	15	1.62
DPOSF5430	523	546	569	54	30	1.3	19	2.08
DPOSF5436	574	614	659	54	36	1.3	23	2.47
DPOSF5442	625	666	713	54	42	1.3	27	2.85
DPOSF5448	672	715	759	54	48	1.3	31	3.25
DPOSF5454	724	766	813	54	54	1.3	34	3.63
DPOSF5460	774	814	860	54	60	1.3	38	4.02
DPOSF6624	557	592	630	66	24	1.3	18	2.04
DPOSF6630	612	647	686	66	30	1.3	23	2.52
DPOSF6636	665	736	812	66	36	1.3	28	3.00
DPOSF6642	721	791	867	66	42	1.3	33	3.46
DPOSF6648	775	857	951	66	48	1.3	38	3.93
DPOSF6654	829	915	1004	66	54	1.3	43	4.40
DPOSF6660	883	966	1060	66	60	1.3	47	4.90

DPOSG • Open Bottom, Slat Middle and Glazed Top Panel

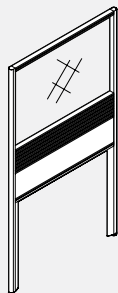

- Integrated 6" slat rail between the middle rails provides flexibility of use.
- Panel integrated slat rail accepts Global Contract Accessories, Monitor Arm Support, Off-Module Shelves, Task Light Bracket and Power Bar.
- Open bottom reduces cost and improves air circulation within the office.
- Extruded aluminum frame surrounds acrylic glazing at top.
- PVC Extrusion is only Charcoal.
- For tempered glass, add "TG" to the end of the product code and add 20% to the price regardless of fabric grade.
- OPT* = Laminate or Whiteboard

PRODUCT CODE	PRICE			SIZE/ INCHES			WEIGHT VOL	
	GR1	GR2	OPT*	H	W	D	LBS	FT ³
DPOSG5024	705	713	718	50	24	1.3	12	1.62
DPOSG5030	759	766	775	50	30	1.3	15	2.08
DPOSG5036	812	825	840	50	36	1.3	18	2.47
DPOSG5042	867	882	895	50	42	1.3	22	2.85
DPOSG5048	918	931	948	50	48	1.3	25	3.25
DPOSG5054	972	986	1000	50	54	1.3	28	3.63
DPOSG5060	1024	1037	1053	50	60	1.3	32	4.02
DPOSG5424	705	713	718	54	24	1.3	14	1.62
DPOSG5430	759	766	775	54	30	1.3	17	2.08
DPOSG5436	812	825	840	54	36	1.3	20	2.47
DPOSG5442	867	882	895	54	42	1.3	24	2.85
DPOSG5448	918	931	948	54	48	1.3	27	3.25
DPOSG5454	972	986	1000	54	54	1.3	30	3.63
DPOSG5460	1024	1037	1053	54	60	1.3	34	4.02
DPOSG6624	765	775	780	66	24	1.3	17	2.04
DPOSG6630	824	830	837	66	30	1.3	21	2.52
DPOSG6636	880	893	908	66	36	1.3	25	3.00
DPOSG6642	936	951	964	66	42	1.3	29	3.46
DPOSG6648	992	1003	1021	66	48	1.3	33	3.93
DPOSG6654	1051	1063	1079	66	54	1.3	37	4.40
DPOSG6660	1108	1122	1137	66	60	1.3	41	4.90

DPFSG • Fabric Bottom, Slat Middle and Glazed Top Panel

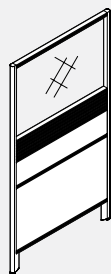

- **Integrated 6" slat rail provides flexibility of use.**
- Panel integrated slat rail accepts Global Contract Accessories, Monitor Arm Support, Off-Module Shelves, Task Light Bracket and Power Bar.
- Extruded aluminum frame surrounds acrylic glazing at top.
- PVC Extrusion is only Charcoal.
- For tempered glass, add "TG" to the end of the product code and add 20% to the price regardless of fabric grade.
- OPT* = Laminate or Whiteboard

PRODUCT CODE	PRICE			SIZE/ INCHES			WEIGHT VOL	
	GR1	GR2	OPT*	H	W	D	LBS	FT ³
DPFSG5024	774	797	825	50	24	1.3	15	1.62
DPFSG5030	831	857	885	50	30	1.3	19	2.08
DPFSG5036	892	962	1037	50	36	1.3	23	2.47
DPFSG5042	951	1022	1095	50	42	1.3	27	2.85
DPFSG5048	1004	1078	1153	50	48	1.3	31	3.25
DPFSG5054	1063	1134	1209	50	54	1.3	35	3.63
DPFSG5060	1122	1194	1267	50	60	1.3	39	4.02
DPFSG5424	774	797	825	54	24	1.3	17	1.62
DPFSG5430	831	857	885	54	30	1.3	21	2.08
DPFSG5436	892	962	1037	54	36	1.3	25	2.47
DPFSG5442	951	1022	1095	54	42	1.3	29	2.85
DPFSG5448	1004	1078	1153	54	48	1.3	33	3.25
DPFSG5454	1063	1134	1209	54	54	1.3	37	3.63
DPFSG5460	1122	1194	1267	54	60	1.3	41	4.02
DPFSG6624	840	865	893	66	24	1.3	20	2.04
DPFSG6630	903	929	956	66	30	1.3	25	2.52
DPFSG6636	962	1033	1108	66	36	1.3	30	3.00
DPFSG6642	1024	1094	1170	66	42	1.3	35	3.46
DPFSG6648	1088	1157	1234	66	48	1.3	40	3.93
DPFSG6654	1147	1218	1294	66	54	1.3	45	4.40
DPFSG6660	1212	1286	1360	66	60	1.3	50	4.90

DPOPF • Diet Over Panel

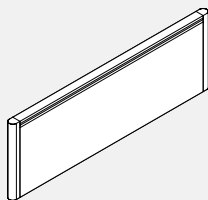

- **Over Panels attach to regular Diet Panels to provide additional visual privacy.**
- Over Panel is secured to regular Diet Panels with 4 brackets and set screws.
- Accessory loading capabilities only.
- Not for use with overhead storage.
- OPT* = Laminate or Whiteboard

PRODUCT CODE	PRICE			SIZE/ INCHES			WEIGHT VOL	
	GR1	GR2	OPT*	H	W	D	LBS	FT ³
DPOPF1224	210	224	238	12	24	1.3	5	0.30
DPOPF1230	239	252	268	12	30	1.3	7	0.60
DPOPF1236	270	299	329	12	36	1.3	8	0.75
DPOPF1242	293	320	351	12	42	1.3	9	0.88
DPOPF1248	324	352	383	12	48	1.3	11	1.00
DPOPF1254	354	384	415	12	54	1.3	12	1.13
DPOPF1260	377	406	435	12	60	1.3	13	1.25
DPOPF2424	291	319	350	24	24	1.3	10	1.00
DPOPF2430	317	344	375	24	30	1.3	14	1.25
DPOPF2436	339	380	425	24	36	1.3	16	1.45
DPOPF2442	361	401	448	24	42	1.3	18	1.75
DPOPF2448	383	425	472	24	48	1.3	22	2.00
DPOPF2454	406	449	491	24	54	1.3	24	2.25
DPOPF2460	431	473	517	24	60	1.3	26	2.50

DTMPP • Table Mounted Diet Panels

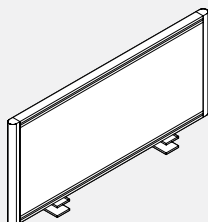

- **Creates privacy and flexibility at the end of work-surfaces.**
- Side Panels for sides of Viceversa® Tables or sides of work-surfaces available 24", and 36" widths (nominal width).
- Back Panels for sides of Viceversa® Tables available 48", 54" and 60" widths.
- Attaches with similar clamp to other clamp on accessories.
- Non tackable, non load-bearing, no hang on capabilities and not for use with transaction tops.
- Not for use with Licence product due to interference of gables and flush modesties.
- OPT* = Laminate or Whiteboard

PRODUCT CODE	PRICE			SIZE/ INCHES			WEIGHT VOL	
	GR1	GR2	OPT*	H	W	D	LBS	FT ³
SIDE PANELS								
DTMPP24	231	241	260	16.5	21	1.3	7	0.75
DTMPP30	247	262	276	16.5	27	1.3	8	0.94
DTMPP36	265	295	324	16.5	33	1.3	10	1.13
BACK PANELS								
DTMPP48	293	320	351	16.5	48	1.3	15	1.53
DTMPP54	320	350	380	16.5	54	1.3	17	1.72
DTMPP60	350	378	409	16.5	60	1.3	18	1.91

DPCBM • Panel Cable Manager

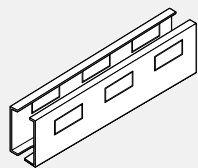

- Provides wire management for the Diet Panels.
- Extruded, dual durometer "U" channel organizes cables below panels.
- Snaps into bottom rail and into mid rail on open bottom panels.
- One data partial knock-out (2.67" wide x 1.36" high) provided on either side of the Raceway Cover accommodates terminal plates from various vendors.
- Panel Cable Manager comes in charcoal only.

PRODUCT CODE	PRICE	SIZE/ INCHES			WEIGHT VOL	
		H	W	D	LBS	FT ³
DPCBM24	16	4	18	1.3	1.3	0.07
DPCBM30	24	4	24	1.3	1.4	0.08
DPCBM36	26	4	30	1.3	1.5	0.10
DPCBM42	29	4	36	1.3	1.6	0.13
DPCBM48	31	4	42	1.3	1.7	0.15
DPCBM54	35	4	48	1.3	1.8	0.16
DPCBM60	37	4	54	1.3	1.9	0.19

DPOFM • Off Module Panel Connector

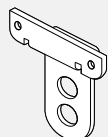

- Connects two perpendicular Diet Panels Off-Module.
- Top and bottom brackets bolt to Diet Panel verticals and engage to top and bottom rails of adjacent, perpendicular panel of even or lower height.
- Connectors can also be used to connect a panel in the middle of perpendicular DPFRR, DPORF, DPFFG, DPFSG ad DPFSF at their 42" height secondary middle rail.
- Top and bottom brackets fit in place of standard hinge connectors.
- All fasteners included.

PRODUCT CODE	PRICE	SIZE/ INCHES			WEIGHT VOL	
		H	W	D	LBS	FT ³
DPOFM	60	4	3	2	1	0.08

DPPWA • Wall Adapter

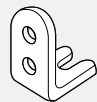
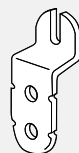

- Connects Diet Panels to walls.
- Bolts to Diet Panel vertical in place of the standard hinge connectors.
- Keyhole openings in Diet adapter slide over fasteners pre-installed to the wall.
- All fasteners included, however, the mounting hardware to affix adapter to wall not included, they will be based on type of wall material.

PRODUCT CODE	PRICE	SIZE/ INCHES			WEIGHT VOL	
		H	W	D	LBS	FT ³
DPPWA	43	40	2.5		1	0.08

DPCSTR • Casters

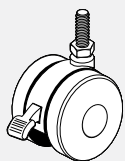

- Changes a freestanding Diet Panel to mobile.
- Must be used on two panels or more.
- Order 1 caster more than the number of panels. (Using only 1 caster where panels connect.) For example, 3 panels, 4 casters or 2 panels, 3 casters.
- Casters raise Diet Panels by a height of 1.1".

PRODUCT CODE	PRICE	SIZE/ INCHES			WEIGHT VOL	
		H	W	D	LBS	FT ³
DPCSTR	12	1.5	1.5	1.5	.25	1.02

DPLTSBKIT • Telescopic Sliding Kit

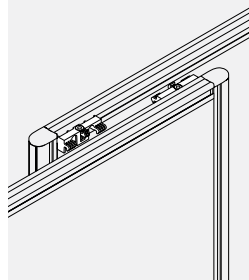

- Diet Telescopic Sliding Kit flexibly connects two standard parallel Diet panels and forms a length-adjustable partition.
- Kit consists of two top and two bottom sliding box assemblies and all the necessary connecting hardware.
- Made of black injection molded resin.
- The panels must be of the same height and equipped with top and bottom standard Diet extrusions.
- The kit can be installed as right or left on site, determining the direction of nesting/sliding.
- The kit offsets the parallel panel and the resulting gap is 12.5mm (½")
- Up to three standard Diet panels can be connected to form the length-adjustable partition.
- The kit is not intended to be used in place of a sliding door.
- The kit cannot be used with Diet overpanels or Diet Linking Panels.

PRODUCT CODE	PRICE	SIZE/ INCHES			WEIGHT VOL	
		H	W	D	LBS	FT ³
DPLTSBKIT	78	0.75	3	0.5	0.04	0.15

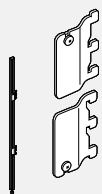
DBSCB • Diet to Boulevard Slot Connector

- Connects a Diet Panel to a Boulevard Panel via slots eliminating the need for the Boulevard Post and reducing the overall length and cost of a panel run.
- Connector can be installed in left or right configuration.
- Comes as a pair (Upper and lower brackets).
- Worksurfaces should be ordered based on application keeping in mind that this connector will align to the left or right of the end of the Boulevard Panel.
- Application drawings and layout must be provided for specials.

PRODUCT CODE	PRICE	SIZE/ INCHES			WEIGHT VOL	
		H	W	D	LBS	FT ³
DBSCB02	58	3	0.5	00.0	1	0.05

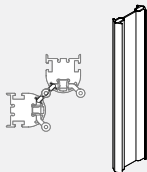
DAPPF • Diet Gap Filler

- Closes the gap between panels.
- Must be used on two or more panels.
- Order 1 DAPPF36 for a 42" high panel, 1 DAPPF36 and 1 DAPPF12 for a 54" high panel, or 1 DAPPF36 and 2 DAPPF12 for 66" high panel.

PRODUCT CODE	PRICE	SIZE/ INCHES			WEIGHT VOL	
		H	W	D	LBS	FT ³
DAPPF12	10	11.5				
DAPPF36	23	36.33				

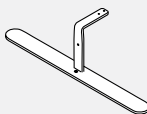
DHFFA • Single Flat Foot

- Used to create a freestanding panel
- Foot is flat to the floor with no adjustable glides
- No load capabilities on freestanding panel
- Only for use with Fabric Bottom panels
- Can be used to retro fit existing Diet panels on site
- Not for use with Diet Linking Panels
- Specify standard panel frame paint finishes

PRODUCT CODE	PRICE	SIZE/ INCHES			WEIGHT VOL	
		H	W	D	LBS	FT ³
DHFFA	100	6	20	2	3.48	0.15

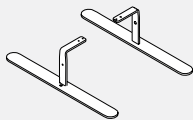
DHFFA02 • Flat Foot Kit

- Used to create a freestanding panel
- Feet are flat to the floor with no adjustable glides
- No load capabilities on freestanding panel
- Cannot be used with open bottom panels or Linking Panels.
- Can be used to retro fit existing Diet panels on site
- Not for use with Diet Linking Panels
- Specify standard panel frame paint finishes

PRODUCT CODE	PRICE	SIZE/ INCHES			WEIGHT VOL	
		H	W	D	LBS	FT ³
DHFFA02	197	6	20	2	7	0.3

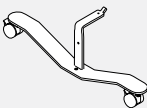
DHCFAN • Single Caster Foot

- Used to create a mobile panel
- Casters are locking
- No load capabilities on mobile panel
- Only for use with Fabric Bottom panels
- Can be used to retro fit existing Diet panels on site
- Not for use with Diet Linking Panels
- Specify standard panel frame paint finishes

PRODUCT CODE	PRICE	SIZE/ INCHES			WEIGHT VOL	
		H	W	D	LBS	FT ³
DHCFAN	131	6	20	2	3.87	0.15

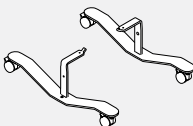
DHCFAN02 • Caster Foot Kit

- Used to create a mobile panel
- Casters are locking
- No load capabilities on mobile panel
- Only for use with Fabric Bottom panels
- Can be used to retro fit existing Diet panels on site
- Not for use with Diet Linking Panels
- Specify standard panel frame paint finishes

PRODUCT CODE	PRICE	SIZE/ INCHES			WEIGHT VOL	
		H	W	D	LBS	FT ³
DHCFAN02	261	6	20	2	7.7	0.3

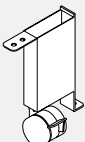
DHCFAL01 • Diet Caster Assembly Kit

- To be used on one side to create a mobile panel with DHCFAN on the other side.
- Caster is locking.
- No load capabilities on mobile panel
- Only for use with Fabric Bottom panels.
- Can be used to retrofit existing Diet panels on site.
- Not for use with Diet Linking Panels.
- Specify standard panel frame paint finishes.

PRODUCT CODE	PRICE	SIZE/ INCHES			WEIGHT VOL	
		H	W	D	LBS	FT ³
DHCFAL01	63	6	1	4.8	1	0.02

DB-P-X • Diet to Boulevard Slim Connector in "X" Configuration

- Creates a perpendicular connection between Diet Panel and Boulevard Panel that eliminates the need for special sized worksurfaces.
- Note: For use with new BDPFF & BDPOF panels.

Diet to Boulevard 1 "X" Configuration

PRODUCT CODE	PRICE	B1 HEIGHT	DIET PANEL HEIGHT	SIZE/ H	INCHES W	D	WEIGHT LBS	VOL FT ³
BDB1P4242X	132	42"	42"	42	1.3	2.6	4	0.207
BDB1P4250X	147	50"	42"	50	1.3	2.6	5	0.245
BDB1P4254X	156	54"	42"	54	1.3	2.6	5	0.264
BDB1P4258X	162	58"	42"	58	1.3	2.6	6	0.283
BDB1P4266X	178	66"	42"	66	1.3	2.6	7	0.322
BDB1P4274X	194	74"	42"	74	1.3	2.6	8	0.360
BDB1P4282X	208	82"	42"	82	1.3	2.6	9	0.399
BDB1P5050X	178	50"	50"	50	1.3	2.6	5	0.245
BDB1P5054X	178	54"	50"	54	1.3	2.6	5	0.264
BDB1P5058X	178	58"	50"	58	1.3	2.6	6	0.283
BDB1P5066X	178	66"	50"	66	1.3	2.6	7	0.322
BDB1P5074X	194	74"	50"	74	1.3	2.6	8	0.360
BDB1P5082X	208	82"	50"	82	1.3	2.6	9	0.399
BDB1P5454X	149	54"	54"	54	1.3	2.6	5	0.264
BDB1P5458X	162	58"	54"	58	1.3	2.6	6	0.283
BDB1P5466X	178	66"	54"	66	1.3	2.6	7	0.322
BDB1P5474X	194	74"	54"	74	1.3	2.6	8	0.360
BDB1P5482X	208	82"	54"	82	1.3	2.6	9	0.399
BDB1P6666X	178	66"	66"	66	1.3	2.6	7	0.322
BDB1P6674X	194	74"	66"	74	1.3	2.6	8	0.360
BDB1P6682X	208	82"	66"	82	1.3	2.6	9	0.399

Diet to System 3 "X" Configuration

PRODUCT CODE	PRICE	SYSTEM 3 HEIGHT	DIET PANEL HEIGHT	SIZE/ H	INCHES W	D	WEIGHT LBS	VOL FT ³
BDB3P4242X	132	42"	42"	42	1.3	2.6	4	0.207
BDB3P4250X	147	50"	42"	50	1.3	2.6	5	0.245
BDB3P4254X	149	54"	42"	54	1.3	2.6	6	0.260
BDB3P4266X	178	66"	42"	66	1.3	2.6	7	0.322
BDB3P5050X	178	50"	50"	50	1.3	2.6	5	0.245
BDB3P5054X	149	54"	50"	54	1.3	2.6	6	0.260
BDB3P5066X	178	66"	50"	66	1.3	2.6	7	0.322
BDB3P5454X	149	54"	54"	54	1.3	2.6	6	0.260
BDB3P5466X	178	66"	54"	66	1.3	2.6	7	0.322
BDB3P6666X	178	66"	66"	66	1.3	2.6	7	0.322

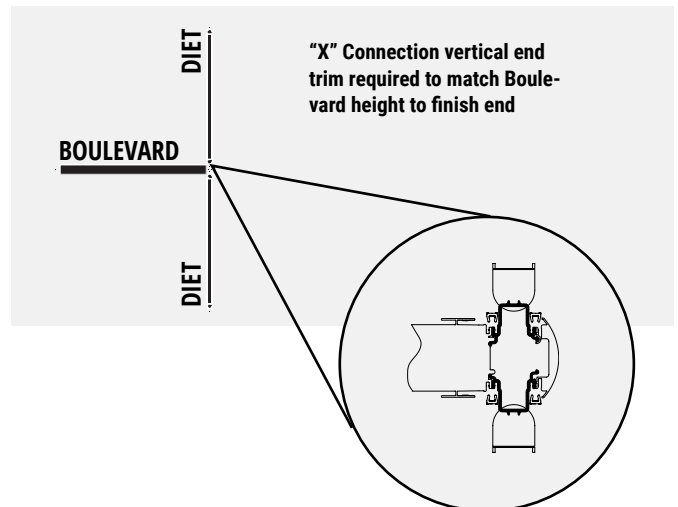
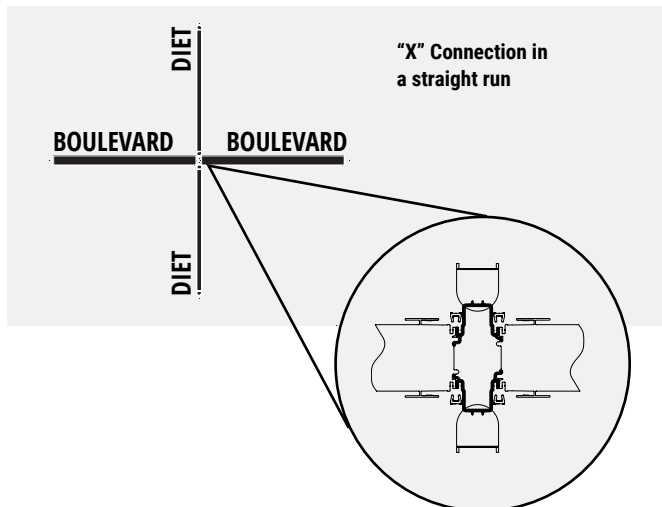

* Please specify separate end trim (round or flat) to close end.

DBXP-T • Diet to Boulevard Slim Connector in "T" Configuration

- Creates a perpendicular connection between Diet Panel and Boulevard Panel that eliminates the need for special sized worksurfaces.
- Note: For use with new BDPFF & BDPOF panels.

Diet to Boulevard 1 "T" Configuration

PRODUCT CODE	PRICE	B1 HEIGHT	DIET PANEL HEIGHT	SIZE/ H	INCHES W	D	WEIGHT LBS	VOL FT ³
BDB1P4242T	132	42"	42"	42	1.3	2.6	4	0.207
BDB1P4250T	147	50"	42"	50	1.3	2.6	5	0.245
BDB1P4254T	156	54"	42"	54	1.3	2.6	5	0.264
BDB1P4258T	162	58"	42"	58	1.3	2.6	6	0.283
BDB1P4266T	178	66"	42"	66	1.6	2.6	7	0.322
BDB1P4274T	194	74"	42"	74	1.3	2.6	8	0.360
BDB1P4282T	208	82"	42"	82	1.3	2.6	9	0.399
BDB1P5050T	178	50"	50"	50	1.3	2.6	5	0.245
BDB1P5054T	178	54"	50"	54	1.3	2.6	5	0.264
BDB1P5058T	178	58"	50"	58	1.3	2.6	6	0.283
BDB1P5066T	178	66"	50"	66	1.3	2.6	7	0.322
BDB1P5074T	194	74"	50"	74	1.3	2.6	8	0.360
BDB1P5082T	208	82"	50"	82	1.3	2.6	9	0.399
BDB1P5454T	149	54"	54"	54	1.3	2.6	6	0.245
BDB1P5458T	162	58"	54"	58	1.3	2.6	6	0.283
BDB1P5466T	178	66"	54"	66	1.3	2.6	7	0.322
BDB1P5474T	194	74"	54"	74	1.3	2.6	8	0.360
BDB1P5482T	208	82"	54"	82	1.3	2.6	9	0.399
BDB1P6666T	178	66"	66"	66	1.3	2.6	7	0.322
BDB1P6674T	194	74"	66"	74	1.3	2.6	8	0.360
BDB1P6682T	208	82"	66"	82	1.3	2.6	9	0.399

Diet to System 3 "T" Configuration

PRODUCT CODE	PRICE	SYSTEM 3 HEIGHT	DIET PANEL HEIGHT	SIZE/ H	INCHES W	D	WEIGHT LBS	VOL FT ³
BDB3P4242T	132	42"	42"	42	1.3	2.6	4	0.207
BDB3P4250T	147	50"	42"	50	1.3	2.6	5	0.245
BDB3P4254T	149	54"	42"	54	1.3	2.6	6	0.245
BDB3P4266T	178	66"	42"	66	1.3	2.6	7	0.322
BDB3P5050T	178	50"	50"	50	1.3	2.6	5	0.245
BDB3P5054T	149	54"	50"	54	1.3	2.6	6	0.245
BDB3P5066T	178	66"	50"	66	1.3	2.6	7	0.322
BDB3P5454T	149	54"	54"	54	1.3	2.6	6	0.245
BDB3P5466T	178	66"	54"	66	1.3	2.6	7	0.322
BDB3P6666T	178	66"	66"	66	1.3	2.6	7	0.322

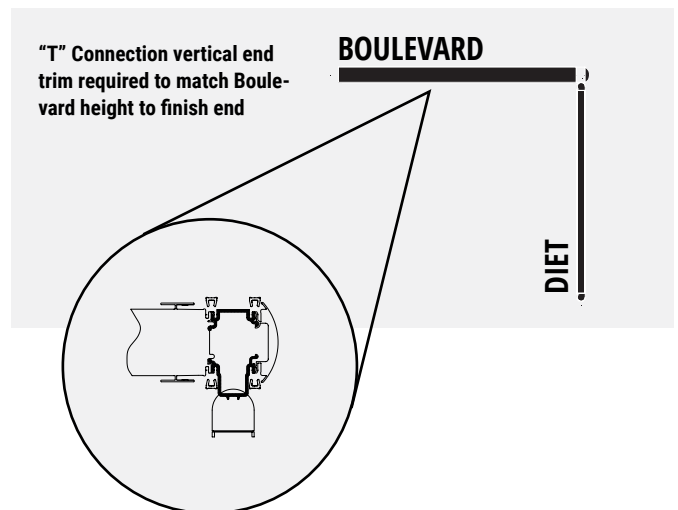
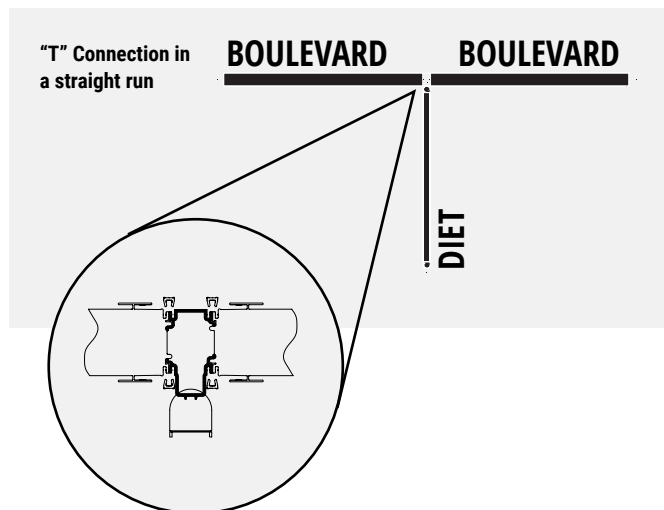

* Please specify separate end trim (round or flat) to close end.

DB-P-X • Diet to Boulevard Slim Connector in "X" Configuration

- Creates a perpendicular connection between Diet Panel and Boulevard Panel that eliminates the need for special sized worksurfaces.
- Note: For use with regular DP panels.

Diet to Boulevard 1 "X" Configuration

PRODUCT CODE	PRICE	B1 HEIGHT	DIET PANEL HEIGHT	SIZE/ H	INCHES W	D	WEIGHT LBS	VOL FT ³
DB1P4242X	132	42"	42"	42	1.3	2.6	4	0.207
DB1P4250X	147	50"	42"	50	1.3	2.6	5	0.245
DB1P4254X	159	54"	42"	54	1.3	2.6	6	0.266
DB1P4266X	178	66"	42"	66	1.3	2.6	7	0.322
DB1P4274X	194	74"	42"	74	1.3	2.6	8	0.360
DB1P4282X	208	82"	42"	82	1.3	2.6	9	0.399
DB1P5050X	178	50"	50"	50	1.3	2.6	5	0.245
DB1P5054X	178	54"	50"	54	1.3	2.6	6	0.266
DB1P5058X	178	58"	50"	58	1.3	2.6	6	0.283
DB1P5066X	178	66"	50"	66	1.3	2.6	7	0.322
DB1P5074X	194	74"	50"	74	1.3	2.6	8	0.360
DB1P5082X	208	82"	50"	82	1.3	2.6	9	0.399
DB1P5458X	162	58"	54"	58	1.3	2.6	6	0.283
DB1P5466X	178	66"	54"	66	1.3	2.6	7	0.322
DB1P5474X	194	74"	54"	74	1.3	2.6	8	0.360
DB1P5482X	208	82"	54"	82	1.3	2.6	9	0.399
DB1P6666X	178	66"	66"	66	1.3	2.6	7	0.322
DB1P6674X	194	74"	66"	74	1.3	2.6	8	0.360
DB1P6682X	208	82"	66"	82	1.3	2.6	9	0.399

Diet to System 3 "X" Configuration

PRODUCT CODE	PRICE	SYSTEM 3 HEIGHT	DIET PANEL HEIGHT	SIZE/ H	INCHES W	D	WEIGHT LBS	VOL FT ³
DB3P4242X	132	42"	42"	42	1.3	2.6	4	0.207
DB3P4250X	147	50"	42"	50	1.3	2.6	5	0.245
DB3P4266X	178	66"	42"	66	1.3	2.6	7	0.322
DB3P5050X	178	50"	50"	50	1.3	2.6	5	0.245
DB3P5066X	178	66"	50"	66	1.3	2.6	7	0.322
DB3P5466X	178	66"	54"	66	1.3	2.6	7	0.322
DB3P5454X	178	54"	54"	54	1.3	2.6	6	0.266
DB3P6666X	178	66"	66"	66	1.3	2.6	7	0.322

Diet to Boulevard 1 Overpanels

PRODUCT CODE	PRICE	OVERPANEL HEIGHT	SIZE/ H	INCHES W	D	WEIGHT LBS	VOL FT ³
DB1OPPC08X	60	8"	8	1.3	2.6	0.8	0.043
DB1OPPC16X	64	16"	16	1.3	2.6	1.6	0.082
DB1OPPC24X	66	24"	24	1.3	2.6	2.5	0.120
DB1OPPC37X	74	37"	37	1.3	2.6	3.5	0.183
DB1OPPC42X	83	42"	42	1.3	2.6	4.0	0.207

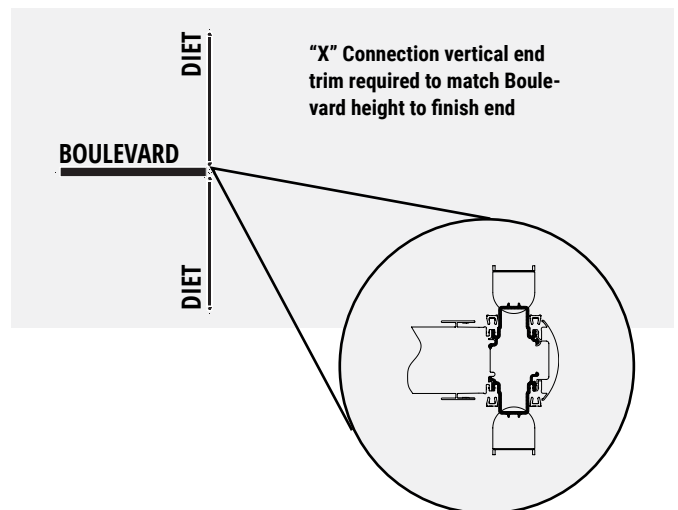
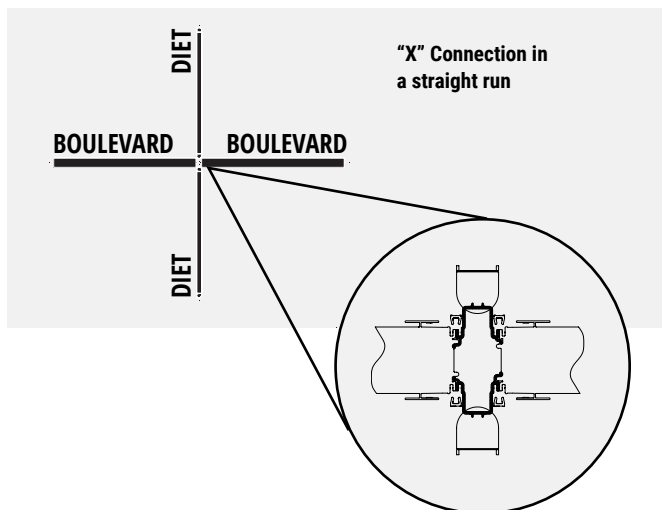

DBXP-T • Diet to Boulevard Slim Connector in "T" Configuration

- Creates a perpendicular connection between Diet Panel and Boulevard Panel that eliminates the need for special sized worksurfaces.
- Note: For use with regular DP panels.

Diet to Boulevard 1 "T" Configuration

PRODUCT CODE	PRICE	B1 HEIGHT	DIET PANEL HEIGHT	SIZE/ H	INCHES W	D	WEIGHT LBS	VOL FT ³
DB1P4242T	132	42"	42"	42	1.3	2.6	4	0.207
DB1P4250T	147	50"	42"	50	1.3	2.6	5	0.245
DB1P4258T	162	58"	42"	58	1.3	2.6	6	0.283
DB1P4266T	178	66"	42"	66	1.6	2.6	7	0.322
DB1P4274T	194	74"	42"	74	1.3	2.6	8	0.360
DB1P4282T	208	82"	42"	82	1.3	2.6	9	0.399
DB1P5050T	178	50"	50"	50	1.3	2.6	5	0.245
DB1P5058T	178	58"	50"	58	1.3	2.6	6	0.283
DB1P5066T	178	66"	50"	66	1.3	2.6	7	0.322
DB1P5074T	194	74"	50"	74	1.3	2.6	8	0.360
DB1P5082T	208	82"	50"	82	1.3	2.6	9	0.399
DB1P5458T	162	58"	54"	58	1.3	2.6	6	0.283
DB1P5466T	178	66"	54"	66	1.3	2.6	7	0.322
DB1P5474T	194	74"	54"	74	1.3	2.6	8	0.360
DB1P5482T	208	82"	54"	82	1.3	2.6	9	0.399
DB1P6666T	178	66"	66"	66	1.3	2.6	7	0.322
DB1P6674T	194	74"	66"	74	1.3	2.6	8	0.360
DB1P6682T	208	82"	66"	82	1.3	2.6	9	0.399

Diet to System 3 "T" Configuration

PRODUCT CODE	PRICE	SYSTEM 3 HEIGHT	DIET PANEL HEIGHT	SIZE/ H	INCHES W	D	WEIGHT LBS	VOL FT ³
DB3P4242T	132	42"	42"	42	1.3	2.6	4	0.207
DB3P4250T	147	50"	42"	50	1.3	2.6	5	0.245
DB3P4266T	178	66"	42"	66	1.3	2.6	7	0.322
DB3P5050T	178	50"	50"	50	1.3	2.6	5	0.245
DP3P5066T	178	66"	50"	66	1.3	2.6	7	0.322
DB3P5466T	178	66"	54"	66	1.3	2.6	7	0.322
DB3P6666T	178	66"	66"	66	1.3	2.6	7	0.322

Diet to System 3 Overpanels

PRODUCT CODE	PRICE	OVERPANEL HEIGHT	SIZE/ H	INCHES W	D	WEIGHT LBS	VOL FT ³
DB30PPC16	64	16"	16	1.3	2.6	1.6	0.082
DB30PPC32	74	32"	32	1.3	2.6	3.2	0.159

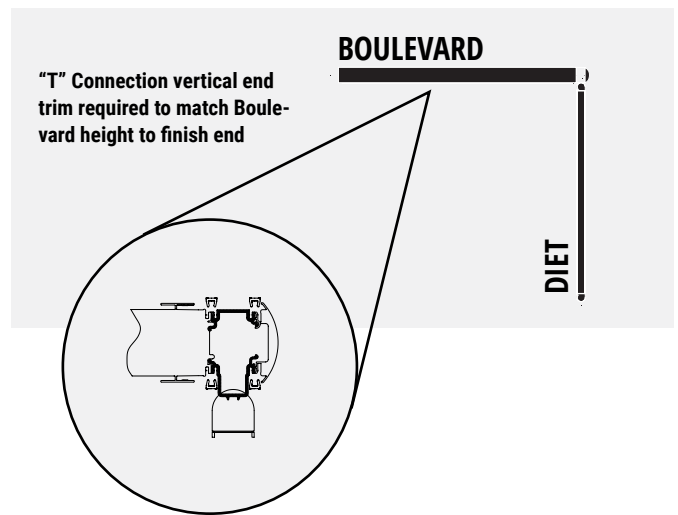
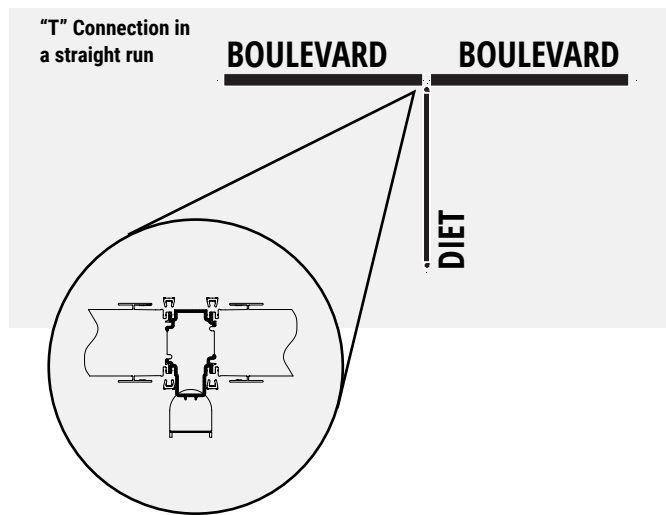

* Please specify separate end trim (round or flat) to close end.

DEK • Jumper Harness



DEK24



DEK30



DEK36-60

• **Kit includes all components to add power to Diet Panels.**

- Typical kit includes: 2 Duplex Receptacle Blocks (either circuit #1 or circuit #2), the Jumper Harness between the Duplex Receptacle Blocks, the Jumper Harness to the next panel, the pre-punched Raceway Cover, the aluminum Raceway Junction Cover, 2 PVC Duplex Receptacle Block Spacers and the hardware to attach the components.
- The length of the Jumper Harness between two Duplex Receptacle Blocks is based on the panel width.
- Jumper Harness going into the next panel and the aluminum Raceway Junction Covers are standard size.
- Raceway Cover and Raceway Junction Cover are Charcoal (CHR) only.
- Each kit is identified as circuit #1 (ie. DEK240*1") or circuit #2 (ie. DEK240*2").
- 24" wide panels have a single Duplex Receptacle Block only.
- 30" wide panels have 2 Duplex Receptacle Blocks, however they must be facing the same direction.
- 24" and 30" wide panels are not pre-punched for data.
- 36" to 60" wide panels are pre-punched for Duplex Receptacle Blocks on either side and for data just off-center on both sides.

PRODUCT CODE	PRICE	SIZE/ INCHES			WEIGHT VOL	
		H	W	D	LBS	FT ³
DEK2401	202	4	18	1.3	4.90	0.07
DEK3001	294	4	24	1.3	5.25	0.08
DEK3601	306	4	30	1.3	5.70	0.10
DEK4201	319	4	36	1.3	6.00	0.13
DEK4801	331	4	42	1.3	6.40	0.15
DEK5401	347	4	48	1.3	7.10	0.16
DEK6001	363	4	54	1.3	7.60	0.19
DEK2402	202	4	18	1.3	4.90	0.07
DEK3002	294	4	24	1.3	5.25	0.08
DEK3602	306	4	30	1.3	5.70	0.10
DEK4202	319	4	36	1.3	6.00	0.13
DEK4802	331	4	42	1.3	6.40	0.15
DEK5402	347	4	48	1.3	7.10	0.16
DEK6002	363	4	54	1.3	7.60	0.19

DEJH • Diet Pass-Thru Kit

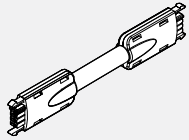

• **Kit allows electrical to pass through a Diet Panel.**

- Kit includes: female-female jumper harness, Raceway Cover and Raceway Junction Cover.
- Pass-Thru harness connects to a Duplex Receptacle Block within one powered panel; passes through a non-powered panel, and the opposite end connects to another Receptacle Block within the second powered panel.
- Raceway Cover and Raceway Junction Cover are Charcoal (CHR) only.

PRODUCT CODE	PRICE	SIZE/ INCHES			WEIGHT VOL	
		H	L	D	LBS	FT ³
DEJH24	140	2	42	1	1.81	0.025
DEJH30	155	2	48	1	2.07	0.028
DEJH36	171	2	54	1	2.12	0.032
DEJH42	184	2	60	1	2.60	0.035
DEJH48	196	2	66	1	2.86	0.038
DEJH54	213	2	72	1	3.13	0.041
DEJH60	226	2	78	1	3.39	0.044

DEBF • Diet Base Feed

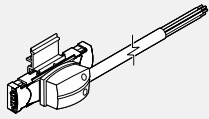

• **Provides single power entry from floor into raceway.**

- Single Ceiling Feed has a 6' whip, liquid tight.
- Raceway connection replaces one Duplex Receptacle Block in a standard kit.

PRODUCT CODE	PRICE	SIZE/ INCHES			WEIGHT VOL	
		H	L	D	LBS	FT ³
DEBF01	197	2	72	2	5.6	0.06

DECF • Diet Ceiling Feed



• **Provides single power entry from ceiling through a post into raceway.**

- Raceway connection replaces one Duplex Receptacle Block in a standard kit.

PRODUCT CODE	PRICE	SIZE/ INCHES			WEIGHT VOL	
		H	L	D	LBS	FT ³
DECF01	299	2	144	2	5.6	0.06

DEPE • Diet Post Extension



• **Lightweight aluminum pole manages power and data cables between ceiling and floor level raceway.**

- Aluminum extrusion with PVC extruded cover secures to the outside of the panel and passes through the worksurface scoop.
- Includes all hardware and bezel.
- Intended for use on Diet panels with fabric bottoms.

PRODUCT CODE	PRICE	SIZE/ INCHES			WEIGHT VOL	
		H	W	D	LBS	FT ³
DEPE116	179	116	4.5	1	7	0.82

DERJC • Raceway Junction Cover

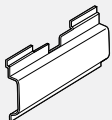

- **Provides an external cover for cables passing between adjacent, in-line panels and off-module "X" panel configurations. Also, capable of bridging two in-line panels in a "T" configuration (outside).**
- Aluminum, powder coated finish.

PRODUCT CODE	PRICE	SIZE/ INCHES			WEIGHT VOL	
		H	W	D	LBS	FT ³
DERJC	23	4.3	10	1	0.5	0.1

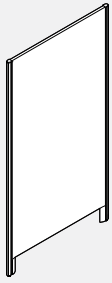
DPL • Linking Panel - Levelers on both legs

- **Diet Linking Panel provides privacy.**
- Aluminum extrusion comes in powder coated paint finish, DWT - Designer White or TUN - Tungsten.
- Laminate core available in DWTLPL - Designer White or ACJLP - Absolute Acajou.
- Edge banded to match laminate finish.
- Standard height of 54", 66", width in 6" increments from 24" to 60".
- Comes complete with hinge kits and levelers on both legs.

PRODUCT CODE	PRICE	SIZE/ INCHES			WEIGHT VOL	
		H	W	D	LBS	FT ³
DPL5424	397	54	24	1.3	18	1.62
DPL5430	441	54	30	1.3	23	2.08
DPL5436	484	54	36	1.3	27	2.47
DPL5442	527	54	42	1.3	32	2.85
DPL5448	573	54	48	1.3	37	3.25
DPL5454	615	54	54	1.3	42	3.63
DPL5460	658	54	60	1.3	47	4.02
DPL6624	450	66	24	1.3	23	2.04
DPL6630	499	66	30	1.3	29	2.52
DPL6636	547	66	36	1.3	35	3.00
DPL6642	593	66	42	1.3	41	3.46
DPL6648	644	66	48	1.3	47	3.93
DPL6654	691	66	54	1.3	53	4.40
DPL6660	739	66	60	1.3	59	4.90

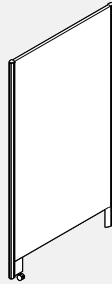
DPLSCH • Diet Laminate Panel - Single caster on one leg, leveler on the other

- **Diet Linking Panel provides privacy.**
- Aluminum extrusion comes in powder coated paint finish, DWT - Designer White or TUN - Tungsten.
- Laminate core available in DWTLPL - Designer White or ACJLP - Absolute Acajou.
- Edge banded to match laminate finish.
- Standard height of 54", 66", width in 6" increments from 24" to 60".
- Comes complete with hinge kits, caster on one leg and leveler on the other.

PRODUCT CODE	PRICE	SIZE/ INCHES			WEIGHT VOL	
		H	W	D	LBS	FT ³
DPLSCH5424	476	54	24	1.3	18	1.62
DPLSCH5430	522	54	30	1.3	23	2.08
DPLSCH5436	568	54	36	1.3	27	2.47
DPLSCH5442	613	54	42	1.3	32	2.85
DPLSCH5448	658	54	48	1.3	37	3.25
DPLSCH5454	705	54	54	1.3	42	3.63
DPLSCH5460	751	54	60	1.3	47	4.02
DPLSCH6624	530	66	24	1.3	23	2.04
DPLSCH6630	580	66	30	1.3	29	2.52
DPLSCH6636	630	66	36	1.3	35	3
DPLSCH6642	681	66	42	1.3	41	3.46
DPLSCH6648	731	66	48	1.3	47	3.93
DPLSCH6654	800	66	54	1.3	53	4.4
DPLSCH6660	830	66	60	1.3	59	4.9

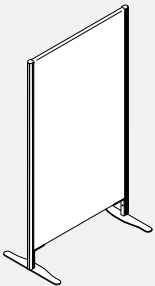
DPLDF • Diet Linking Panel - Flat foot on both legs

- **Diet Linking Panel provides privacy.**
- Aluminum extrusion comes in powder coated paint finish, DWT - Designer White or TUN - Tungsten.
- Laminate core available in DWTLPL - Designer White or ACJLP - Absolute Acajou.
- Edge banded to match laminate finish.
- Standard height of 54", 66", width in 6" increments from 24" to 60".
- Comes complete with hinge kits and flat foot on both legs.

PRODUCT CODE	PRICE	SIZE/ INCHES			WEIGHT VOL	
		H	W	D	LBS	FT ³
DPLDF5424	544	54	24	1.3	40.2	1.6
DPLDF5430	582	54	30	1.3	47.6	2.1
DPLDF5436	619	54	36	1.3	54.9	2.5
DPLDF5442	657	54	42	1.3	62.3	2.9
DPLDF5448	695	54	48	1.3	69.6	3.3
DPLDF5454	734	54	54	1.3	77.0	3.6
DPLDF5460	774	54	60	1.3	84.3	4.0
DPLDF6624	589	66	24	1.3	48.6	2.0
DPLDF6630	630	66	30	1.3	57.9	2.5
DPLDF6636	673	66	36	1.3	67.3	3.0
DPLDF6642	714	66	42	1.3	76.6	3.5
DPLDF6648	757	66	48	1.3	85.9	3.9
DPLDF6654	797	66	54	1.3	95.2	4.4
DPLDF6660	840	66	60	1.3	104.5	4.9

DPLMN • Diet Linking Panel - Double caster base on both legs

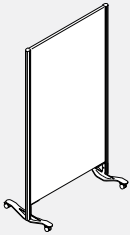

- **Diet Linking Panel provides privacy.**
- Aluminum extrusion comes in powder coated paint finish, DWT - Designer White or TUN - Tungsten.
- Laminate core available in DWTL - Designer White or ACJLP - Absolute Acajou.
- Edge banded to match laminate finish.
- Standard height of 54", 66", width in 6" increments from 24" to 60".
- Comes complete with hinge kits, and double caster foot on both legs.

PRODUCT CODE	PRICE	SIZE/ INCHES			WEIGHT VOL	
		H	W	D	LBS	FT ³
DPLMN5424	578	54	24	1.3	41.8	1.6
DPLMN5430	627	54	30	1.3	49.1	2.1
DPLMN5436	679	54	36	1.3	56.5	2.5
DPLMN5442	726	54	42	1.3	63.8	2.9
DPLMN5448	779	54	48	1.3	71.2	3.3
DPLMN5454	828	54	54	1.3	78.5	3.6
DPLMN5460	879	54	60	1.3	85.8	4.0
DPLMN6624	641	66	24	1.3	50.2	2.0
DPLMN6630	693	66	30	1.3	59.5	2.5
DPLMN6636	749	66	36	1.3	68.8	3.0
DPLMN6642	805	66	42	1.3	78.1	3.5
DPLMN6648	860	66	48	1.3	87.4	3.9
DPLMN6654	916	66	54	1.3	96.8	4.4
DPLMN6660	971	66	60	1.3	106.1	4.9

DPLDCMN • Diet Linking Panel - Single caster on one leg and double caster base on the other

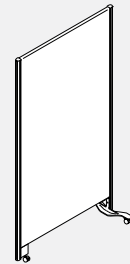

- **Diet Linking Panel provides privacy.**
- Aluminum extrusion comes in powder coated paint finish, DWT - Designer White or TUN - Tungsten.
- Laminate core available in DWTL - Designer White or ACJLP - Absolute Acajou.
- Edge banded to match laminate finish.
- Standard height of 54", 66", width in 6" increments from 24" to 60".
- Comes complete with hinge kits, single caster on the one leg and double caster foot on the other.

PRODUCT CODE	PRICE	SIZE/ INCHES			WEIGHT VOL	
		H	W	D	LBS	FT ³
DPLDCMN5424	543	54	24	1.3	37.6	1.6
DPLDCMN5430	591	54	30	1.3	45.0	2.1
DPLDCMN5436	639	54	36	1.3	52.3	2.5
DPLDCMN5442	688	54	42	1.3	59.7	2.9
DPLDCMN5448	736	54	48	1.3	67.0	3.3
DPLDCMN5454	783	54	54	1.3	74.4	3.6
DPLDCMN5460	830	54	60	1.3	81.7	4.0
DPLDCMN6624	602	66	24	1.3	46.0	2.0
DPLDCMN6630	654	66	30	1.3	55.3	2.5
DPLDCMN6636	707	66	36	1.3	64.7	3.0
DPLDCMN6642	758	66	42	1.3	74.0	3.5
DPLDCMN6648	812	66	48	1.3	83.3	3.9
DPLDCMN6654	863	66	54	1.3	92.6	4.4
DPLDCMN6660	917	66	60	1.3	101.9	4.9

DPLDCHN • Diet Linking Panel - Leveler on one leg and double caster base on the other



- **Diet Linking Panel provides privacy.**
- Aluminum extrusion comes in powder coated paint finish, DWT - Designer White or TUN - Tungsten.
- Laminate core available in DWTL - Designer White or ACJLP - Absolute Acajou.
- Edge banded to match laminate finish.
- Standard height of 54", 66", width in 6" increments from 24" to 60".
- Comes complete with hinge kits, leveler on one leg and double caster foot on the other.

PRODUCT CODE	PRICE	SIZE/ INCHES			WEIGHT VOL	
		H	W	D	LBS	FT ³
DPLDCHN5424	512	54	24	1.3	37.1	1.6
DPLDCHN5430	556	54	30	1.3	44.5	2.1
DPLDCHN5436	608	54	36	1.3	51.8	2.5
DPLDCHN5442	655	54	42	1.3	59.2	2.9
DPLDCHN5448	701	54	48	1.3	66.5	3.3
DPLDCHN5454	751	54	54	1.3	73.9	3.6
DPLDCHN5460	799	54	60	1.3	81.2	4.0
DPLDCHN6624	568	66	24	1.3	45.5	2.0
DPLDCHN6630	621	66	30	1.3	54.9	2.5
DPLDCHN6636	673	66	36	1.3	64.2	3.0
DPLDCHN6642	724	66	42	1.3	73.5	3.5
DPLDCHN6648	779	66	48	1.3	82.8	3.9
DPLDCHN6654	830	66	54	1.3	92.1	4.4
DPLDCHN6660	885	66	60	1.3	101.4	4.9

DPLWA • Wall Connection for Linking Panels

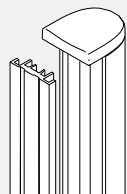

- **Wall Connection connects Linking**
- Panels to walls.
- Aluminum extrusion comes in powder coated paint finish, DWT - Designer White or TUN - Tungsten.
- Kit consists of Diet vertical extrusion, charcoal PVC cover and hinge kits.

PRODUCT CODE	PRICE	SIZE/ INCHES			WEIGHT VOL	
		H	W	D	LBS	FT ³
DPLWA54	103	54	2	2	2.3	0.13
DPLWA66	115	66	2	2	3.5	0.15

DPLEKIT • Expanding Kit

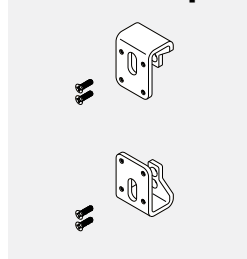

- **Expanding Kit connects two linking panels in a straight line.**
- This kit will accommodate any special width by overlapping the panels.
- Aluminum extrusion comes in powder coated paint finish, DWT - Designer White or TUN - Tungsten.
- Kit consists of a top and bottom bracket and all the hardware needed.

PRODUCT CODE	PRICE	SIZE/ INCHES			WEIGHT VOL	
		H	W	D	LBS	FT ³
DPLEKIT	179	3	2	2.0	1	0.05

DP • Door and Door Catch Kit for Linking Panels

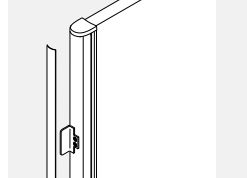

- **Door Catch Kit converts any Linking Panel into a door.**
- Aluminum extrusion comes in powder coated paint finish, DWT - Designer White or TUN - Tungsten.
- Kit consists of striker plate, two hinge kits, single caster foot assembly and 1" Diet caster

PRODUCT CODE	PRICE	SIZE/ INCHES			WEIGHT VOL	
		H	W	D	LBS	FT ³
DPDC01	112	6	3	1.3	2	0.50

DP • Over Panel for Linking Panels

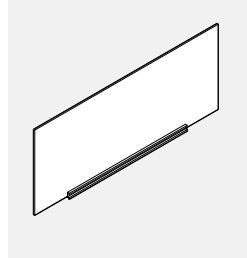

- **Over Panel sits atop of Linking Panel and bridges the gap between the top of 66" high Linking Panel and the top of the Screening Booth.**
- Kit contains aluminum extrusion and felt insert.
- Aluminum extrusion comes in powder coated paint finish, DWT - Designer White or TUN - Tungsten.

PRODUCT CODE	PRICE	SIZE/ INCHES			WEIGHT VOL	
		H	W	D	LBS	FT ³
DPLOP24	92	16.8	24	1.05	1.74	0.39
DPLOP30	108	16.8	30	1.05	2.20	0.49
DPLOP36	128	16.8	36	1.05	2.67	0.59
DPLOP42	143	16.8	42	1.05	3.14	0.70
DPLOP48	212	16.8	48	1.05	3.60	0.80
DPLOP54	231	16.8	54	1.05	4.07	0.90
DPLOP60	248	16.8	60	1.05	4.35	1.01

DP • Booth to Linking Panel Connector

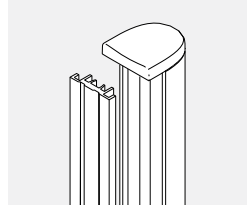

- **Booth to Linking Panel Connector facilitates the connection of a Linking Panel to the back gable edge of the Screening Booth.**
- Aluminum extrusion comes in powder coated paint finish, DWT - Designer White or TUN - Tungsten.
- Kit includes a Diet vertical extrusion, charcoal PVC cover and all hardware.

PRODUCT CODE	PRICE	SIZE/ INCHES			WEIGHT VOL	
		H	W	D	LBS	FT ³
DEBPA	79	66	3	1.3	3.5	0.15

DPVAC • Diet VAC Laminate Panels

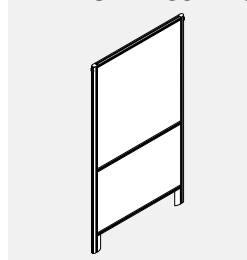

- **Special panel construction designed specifically for clinical applications.**
- Segmentented panels offer a thermally fused laminate lower and high pressure upper pressed on a lightweight core.
- Minimal footprint for storage.
- Easy to connect.
- Easy to reconfigure.
- Easy to clean.
- Laminate core available in DWTL/HP Designer White or ACJLP/ACJHP Absolute Acajou.
- Aluminum extrusion comes in powder coated paint finish. DWT Designer White or TUN Tungsten.
- Comes completed with hinge kits and levelers on both legs.

PRODUCT CODE	PRICE	SIZE/ INCHES			WEIGHT VOL	
		H	W	D	LBS	FT ³
DPVAC6636	689	66	36	1.3	35	3.00
DPVAC6642	711	66	42	1.3	41	3.46
DPVAC6648	724	66	48	1.3	47	3.93
DPVAC6660	1091	66	60	1.3	59	4.90

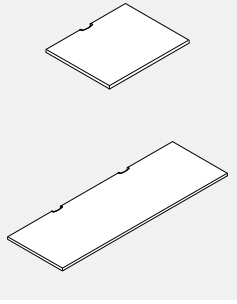
DWS • Worksurface for Diet Panels

- **Worksurfaces have scoops at back to allow wires and cables to pass to and from floor level.**
- Includes support brackets (DHBRKT), 4 for work-surfaces up to 48", and 5 for any worksurface longer than 48".
- Please choose from DWT - Designer White, SIL - Silver or BLK - Black for scoop covers.

PRODUCT CODE	PRICE LP*	HP*	SIZE/ INCHES			WEIGHT VOL	
			H	W	D	LBS	FT ³
DWS2424P	149	187	1	24	24	15	0.60
DWS2430P	159	199	1	30	24	19	0.72
DWS2436P	180	225	1	36	24	23	0.85
DWS2442P	235	295	1	42	24	27	0.98
DWS2448P	283	353	1	48	24	31	1.11
DWS2454P	333	412	1	54	24	35	1.23
DWS2460P	373	465	1	60	24	39	1.36
DWS2466P	389	485	1	66	24	43	1.49
DWS2472P	408	509	1	72	24	48	1.62
DWS3024P	174	218	1	24	30	19	0.74
DWS3030P	190	236	1	30	30	24	0.90
DWS3036P	221	278	1	36	30	29	1.06
DWS3042P	313	392	1	42	30	34	1.22
DWS3048P	333	412	1	48	30	39	1.38
DWS3054P	364	454	1	54	30	43	1.54
DWS3060P	389	485	1	60	30	48	1.69
DWS3066P	406	508	1	66	30	53	1.85
DWS3072P	430	537	1	72	30	58	2.01

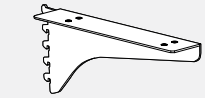
BHC • Diet/Boulevard Worksurface 12" Cantilever Support

- An economical way to connect rear part of the side edge of a worksurface to the Boulevard Panel.
- Front part of the side edge of the worksurface must be supported by an off-module Diet Worksurface Bracket and locked into the adjacent Diet Panel.
- This cantilever is not a shared support

PRODUCT CODE	PRICE	SIZE/ INCHES			WEIGHT VOL	
		H	W	D	LBS	FT ³
BHC12L	41	6	2	12	2	0.03
BHC12R	41	6	2	12	2	0.03

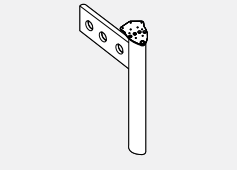
DHLEG • Diet Gable Leg

- **Universal leg, plate and side panel are non handed.**
- Supports the worksurface at 29° and enhances the stability of connected panels.
- Side plate is secured to the side of the Diet panel and leg plate bolts to worksurface.
- Made of extruded aluminum and steel.
- Levelers have 1.75" height adjustment.
- Includes all mounting hardware to connect to panel and worksurface.
- Must attach to Diet Panel vertical.

PRODUCT CODE	PRICE	SIZE/ INCHES			WEIGHT VOL	
		H	W	D	LBS	FT ³
DHLEG	211	28	23	6	12	2.02

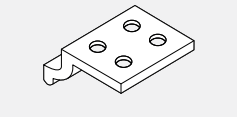
DHBRKT • Diet Worksurface Bracket

- **Extruded aluminum bracket that is bolted to the underside of the worksurface.**
- Bracket supports worksurface at any location along the mid rail of panel.
- Includes mounting hardware.
- Brackets are included for all worksurfaces DWS, 4 for worksurfaces up to 48", and 5 for any worksurface longer than 48".

PRODUCT CODE	PRICE	SIZE/ INCHES			WEIGHT VOL	
		H	W	D	LBS	FT ³
DHBRKT	11	0.75	2.25	3.25	0.1	0.05

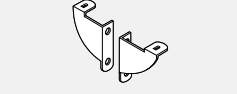
DHTBRKT • Diet Transaction Bracket

- Connects transaction tops to Diet Panels.
- Includes 1 set of two brackets and all hardware.

PRODUCT CODE	PRICE	SIZE/ INCHES			WEIGHT VOL	
		H	W	D	LBS	FT ³
DHTBRKT	41	2.5	1.2	2.5	3	0.01

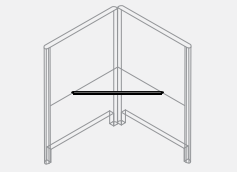
DWSCSB • Diet Support Bar

- **Supports worksurface in 90 degree corner application and eliminates the need for a leg.**
- Diagonally installed.
- If using a keyboard, spacers will be required.

PRODUCT CODE	PRICE	SIZE/ INCHES			WEIGHT VOL	
		H	W	D	LBS	FT ³
DWSCSB46	109	1	46	1	7	0.116
DWSCSB80	157	1	80	1	12	0.189

For corner application where 24" deep or smaller adjoining worksurface:
For corner application where adjoining worksurface is larger than 24":

DHOMC • Diet Off-Module Cantilever

- **To be used with Diet Panels that have a fabric bottom.**
- Installs on horizontal rails of panels to provide worksurface support.
- Frees up space under the worksurface.

PRODUCT CODE	PRICE	SIZE/ INCHES			WEIGHT VOL	
		H	W	D	LBS	FT ³
DHOMC	109	21	3	12	4	0.42

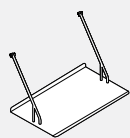
DSOMSHLF • Diet Off Module 24" Shelf

- Shelf hangs anywhere along Diet panel rails or Boulevard System 3 panel accessory tile.
- Can create a supplementary surface at worksurface level when suspended from a 42" high Diet panel.
- Shelves may be stacked, one hanging above the other from a higher rail.
- Shelf made of formed steel and includes suspended arms made of steel.

PRODUCT CODE	PRICE	SIZE/	INCHES			WEIGHT VOL	
		H	W	D	LBS	FT ³	
DSOMSHLF	246	11.5	24	12	4	1.00	

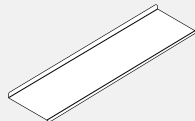
DSOS • Diet Panel Mounted Shelf

- Provides overhead storage capacity on top of 42" and 54" high Diet panels.
- Made of formed steel and includes steel mounting brackets.
- Support brackets lock to the top of Diet rail at the back and both sides of overhead.
- Must be installed on a "U" or "H" panel configuration.
- Due to structural issues, this product may not be used on top of glazed or partially glazed panels.

PRODUCT CODE	PRICE	SIZE/	INCHES			WEIGHT VOL	
		H	W	D	LBS	FT ³	
DSOS48	297	15	48	13.5	40	5.60	
DSOS60	316	15	60	13.5	52	7.00	

DOHLS • Diet Overhead Support

- To be used with Diet back panel and Diet wing panel either left or right. The support leg will support only one side and eliminate the need for a third panel.
- To be used and supported on worksurface installed at standard height. Ensure the worksurface that the leg sits on is properly supported.

PRODUCT CODE	PRICE	SIZE/	INCHES			WEIGHT VOL	
		H	W	D	LBS	FT ³	
DOHLS42	375	12	2	3.5	4	0.139	
DOHLS54	406	24	2	3.5	6	0.278	

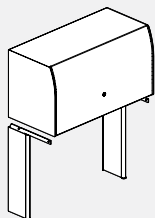
DSADA • Easy-Up Diet Overhead

- Diet Panel mounted metal overhead storage with opaque acrylic door. The Metal finish (page A.29). mechanism lifts the door up and stores it out of the way, above the storage unit.
- Meets CSA B651 Barrier Free Design & AODA (Accessibility for Ontarians with Disabilities Act).
- Meets CSA B651 Barrier Free Design & ADA (Americans with Disabilities Act).
- 16" high units accept standard and A4 binders.
- All shelves are reinforced for proper weight distribution.
- Inside dimensions: 14.375" high x 12" deep.
- Unit includes back, support cantilevers, attachment hardware, and lock.
- Shipped partially assembled.

PRODUCT CODE	PRICE	SIZE/	INCHES			WEIGHT VOL	
		H	W	D	LBS	FT ³	
DSADA30PM	1050	16	30	14.4	33	5.3	
DSADA36PM	1095	16	36	14.4	38	6.3	
DSADA42PM	1145	16	42	14.4	43	7.3	
DSADA48PM	1201	16	48	14.4	48	8.3	
DSADA54PM	1256	16	54	14.4	53	9.3	
DSADA60PM	1317	16	60	14.4	59	10.3	

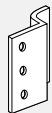
DHPEDB • Pedestal Bracket Kit for Diet Panels

- Attaches to a metal Worksurface Supporting Pedestal at the back and connects the pedestal to the Diet Panel vertical.

PRODUCT CODE	PRICE	SIZE/	INCHES			WEIGHT VOL	
		H	W	D	LBS	FT ³	
DHPEDB	36	8	1	1	0.5	0.001	

Introduction

Compile Systems - Protecting the Environment for Future Generations

- Our environmental success story began with the challenge to create an office system that would meet today's business requirements while maintaining a firm commitment to save and protect the environment.
- Sustainability became a part of the creative focus and development of Compile that incorporates the latest technology and design features to provide excellent performance at a competitive price.
- As government and industry environment ratings such as LEED & Greenguard become more prevalent, Compile offers designers and architects functional, attractive, and economical office designs that meet these standards.
- Global Contract is a leader in reducing waste in the manufacturing of its products as well as utilizing recycled materials wherever possible. We make extensive use of recycled plastic and wood waste from other Global factories.
- Global Contract is committed to the continuous improvement of our environmental systems, the prevention of pollution, and to comply with both the spirit and the letter of all relevant environmental legislation.

- Compile Panels are 82.3% recyclable at the end of their lifespan. Nothing from a Compile Panel needs to end up in a landfill.

Compile Systems - Product Information

- Compile offers fabrics that are made from 100% recycled polyester, which means less waste going to landfills. These fabrics also reduced the demand for petroleum products, and decrease the environmental impacts of processing those petroleum products into polyester.
- Compile's epoxy powder coating process involves no liquids and is solvent free. It contains no harmful VOC's or lead. Up to 99% of over sprayed powder is reclaimed, mixed with virgin powder and resused.
- Compile's entire panel is up to 82.3% recycled.
- Compile masonite is up to 85% recycled.
- Compile recycled wood for worksurfaces is up to 85% recycled.
- Compile's entire product line is up to 99.9% recyclable.

Components • Panel Configuration

Many components make up a panel configuration. This page provides an exploded view of a sample configuration highlighting each panel component required when specifying this configuration.

- A) CMET66 66"h. End of Run Trim Insert for Panel
- B) CMFF6636 66"h. x 36"w Single Segmented Fabric Panel
- C) CHP66 66"h. Universal Corner Post
- D) CMETP66 Trim Insert for 66"h. Universal Corner Post
- E) CMPC2 Post Base Cover for 2-Way Application
- F) CMET24 24"h Trim Insert for Step Down
- G) CMFF4236N1 42"h. x 36"w Single Segmented Fabric Panel, Punchouts on one side.
- H) CMET42 42"h. End of Run Trim Insert for Panel
- I) CMRC36NP 36"w Raceway Cover without Knockouts (if ordered separately)
- J) Panel Connectors, comes standard with panels and universal corner post

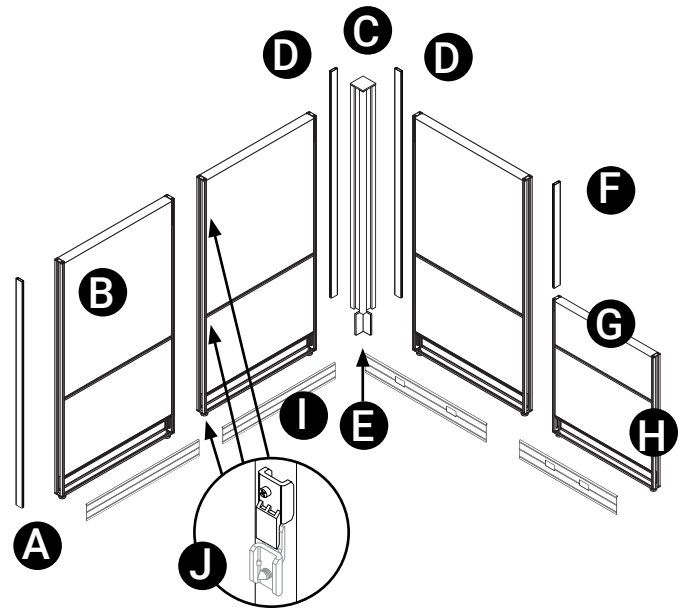

Components • Worksurfaces

- Compile thermally fused Worksurfaces are 1" thick and are finished with 3 mm PVC edging on all sides.
- Worksurfaces have pilot holes to enable proper alignment with worksurface supports.
- Most standard laminate offerings are available in thermally-fused. See laminate listings for details.
- Wood grain laminates on corner worksurfaces up to 42" available with laminate running diagonally at an upcharge. Otherwise, standard horizontal application of laminate will be used, as per drawings at right.
- Most wood grain laminate worksurfaces will have matching woodgrain trim unless specified otherwise.
- Depth of the worksurface scoops are 1 1/8" when measured from the panel the worksurface is attached to.
- All worksurfaces require support items. These are priced separately within this section.
- Grain direction for worksurfaces are as follows:
- Communication and electrical wires are routed through a cable scoop located at the back of the worksurface. When specifying a Straight Worksurface (CWS) or a Curvilinear Worksurface (CWVL), note that the number of cable scoops depends upon the width of the worksurface. All other Worksurface shapes have one scoop on panel edges.

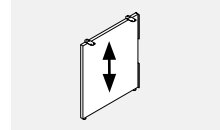

CHEP End Panels

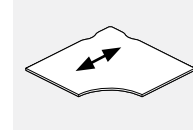

CWCC Worksurfaces

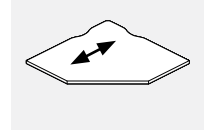

CWCF Worksurfaces

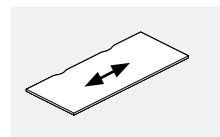

CWS Worksurfaces

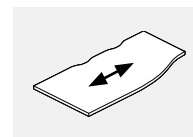

CWVL/R Worksurfaces

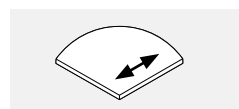
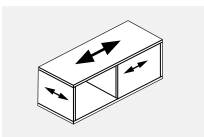

CWQRC Worksurfaces



One Scoop CWVL
24" - 54"



Two Scoop CWVL
60" - 84"

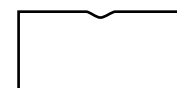

One Scoop CWS
24" - 54"

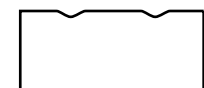

Two Scoop CWS
60" - 84"

Components • Electrical

2+2 Configuration (8 wire, 4 circuit)

Two Utility Circuits [Compile's #1 & #2 circuits] share one neutral wire and one (system) ground wire. (2 hot [circuit] wires + 1 neutral wire*** + 1 green ground wire* = 4 wires)

Two Dedicated Circuits [Compile's "A" & "B" circuits] share one neutral wire and one (isolated) ground wire. (2 hot [circuit] wires + neutral wire *** + 1 green/yellow ground wire** = 4 wires)

Note: It is the ground wire that makes the difference between "Utility" and "Dedicated" circuits. Refer to Wiring Schematics found above.

*A Green ground wire is a "system" ground. This means it could be grounded to any piece of metal, including the panel.

**A Green/Yellow ground wire is isolated, within the wiring conduit, all the way back to the box at the source (building ground).

***All neutral wires are 10 gauge rather than 12 gauge meaning they are larger than normal allowing greater protection against 'noise' or interference on the circuit.

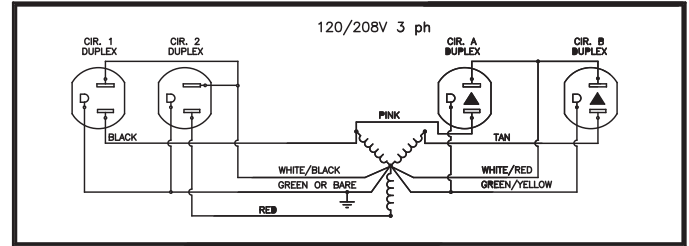
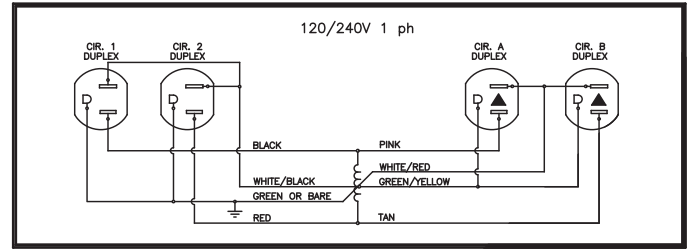

UL RECOGNIZED AND CSA CERTIFIED

Warning: It is recommended that installation of the electrical harness be made under the supervision of a licensed electrician in accordance with applicable codes and regulations.

Special Note: Always ensure that harness is electrically connected to only one power supply.

Components • Panel Configuration - Electrical

Many components make up a configuration. This page provides an exploded view of a sample configuration highlighting each Electrical component required when specifying this configuration.

A) CE8PD36 Power Distribution Housing

Note: 8 wire, 4 circuits, 2+2 configuration

B) CE8CP17 Flexible Mesh Jumper Cable (connects two panels side by side or separated by a post in a corner application)

C) CE8RD Duplex Receptacle

D) CE8CI1 "I" Connector

E) CE8CP Pass-Through Cable

Note: Must run in a straight line application only

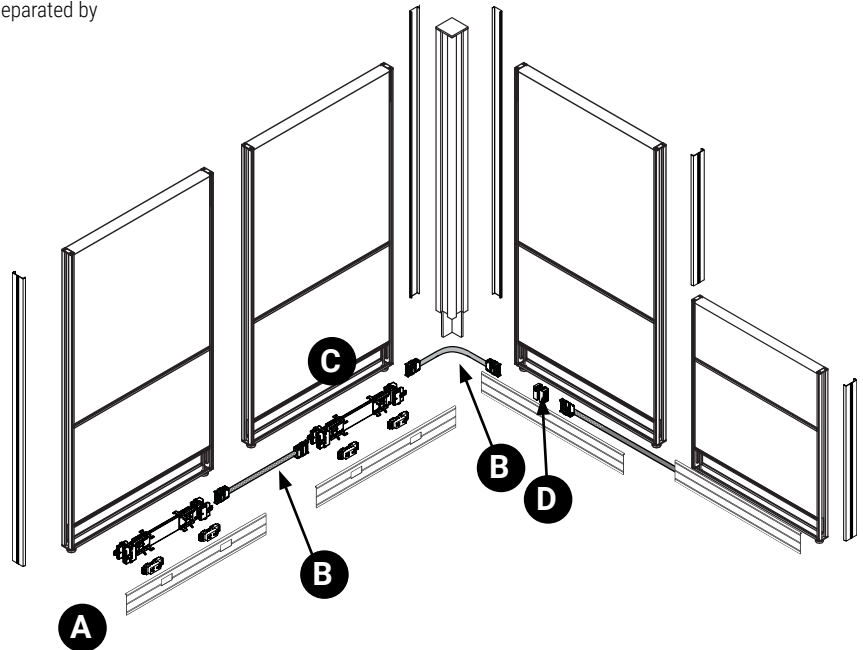

PANEL FINISHES

Panel Frame

Black	BLK
Designer White	DWT
Nevada	NEV
Fog	FOG

Glazing Options

Clear	CLR
Frosted	FRS

COMPILE - GUIDELINES FOR ORDERING PRODUCT

Codes

The product guide uses a numbering system with meaningful alphanumeric characters to create a simple-to-understand product number. This makes specifying the product much easier and more accurate.

Example of Panel **CMFM4236** Product Code

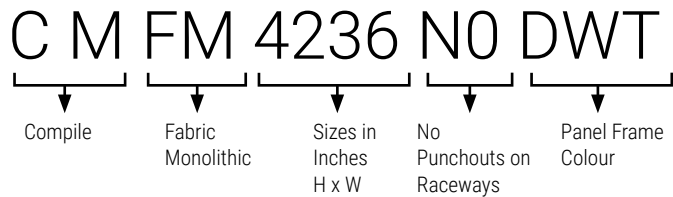

How to Specify

- Specify Compile panel type and size by code.
- Specify panel frame finish - ie. DWT (Designer White)
- Specify raceway power option.
- Specify all necessary panel fabric options.

The information listed below provides you with basic features of Compile Panels.

- Compile Panels can only be stacked one high.
- Available in four (4) basic heights: 30", 42", 54" and 66"; and seven (7) widths: 24", 30" 36", 42", 48", 54" and 60".
- 2 3/8" thick.
- Available in Monolithic and Single Segmented at just below the worksurface.
- Compile panels are not tackable.
- Raceway openings are 1.345" x 2.80".
- Opposite sides of each Module may have a different fabric within the same grade at no upcharge.
- Standard with aluminum frame.
- Individual fabric covered modules incorporated into an aluminum frame.
- Aluminum raceway covers can be ordered separately and shipped separately for reconfigurations. Raceway covers can be replaced in the field to change a panel from non powered to powered (or vice versa).

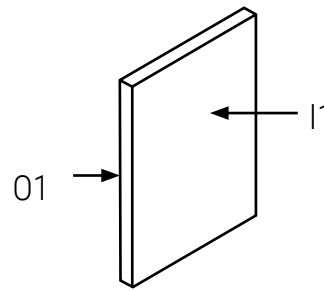

I1 AN50
O1 BE21

Inside Fabric Position #1

Outside Fabric Position #1

NOTE: If different grades of fabric are used on one panel, the entire panel must be priced out at the higher grade.

- On Compile Laminate and Gallery panels, if a wood grain laminate is chosen, grain direction runs horizontally.
- Base raceway lifts up and locks in an upright 90-degree position, or can be removed for open access to base raceway.
- Electric knockouts in the raceway have plastic covers that snap into place from the outside of the cover, when a duplex is not required. Electric knockout covers must be specified separately.
- 3 panel connector brackets per side for 30"h., 42"h. and 54"h. come installed on panels and 60° and 90° posts.
- 4 panel connector brackets per side for 66"h. panels come installed on panels and 60° and 90° posts.
- Panel connector brackets are opposite direction of each other per panel side, and can be removed with one screw per bracket.
- CMFF and CMFM 66" and 72" panels must have fabric railroaded. Please confirm at time of order if all panels or only those need fabric to be railroaded.

CMFM-N0 • Monolithic Non Powered Fabric Panel, No Punchouts

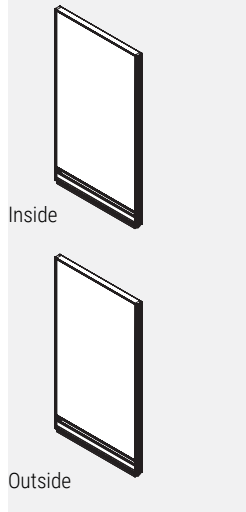

- Individual fabric-covered modules incorporated into an aluminum frame.
- Opposite sides of each module may have a different fabric within the same grade at no upcharge.
- If different grades of fabric are used on one panel, the entire panel must be priced at highest grade.
- Panels are not tackable.
- 3 Panel connector brackets per side come standard with 30”h., 42”h. and 54”h. panels.
- 4 Panel connector brackets per side come standard with 66”h. panels.
- Panels include 2 raceway covers with no punchouts, an integrated aluminum top cap and levelling glides.
- Note: Trim is not required at a straight connection between two panels of the same height.

PRODUCT CODE	PRICE		SIZE/ INCHES			WEIGHT VOL	
	GR 1	GR 2	H	W	D	LBS	FT³
CMFM3024N0	271	298	30	24	2.3	20	2.31
CMFM3030N0	336	363	30	30	2.3	25	2.85
CMFM3036N0	365	412	30	36	2.3	31	3.38
CMFM3042N0	399	450	30	42	2.3	36	3.92
CMFM3048N0	433	483	30	48	2.3	41	4.45
CMFM3054N0	477	524	30	54	2.3	46	4.99
CMFM3060N0	507	553	30	60	2.3	51	5.52
CMFM4224N0	271	298	42	24	2.3	20	2.31
CMFM4230N0	336	363	42	30	2.3	25	2.85
CMFM4236N0	365	412	42	36	2.3	31	3.38
CMFM4242N0	399	450	42	42	2.3	36	3.92
CMFM4248N0	433	483	42	48	2.3	41	4.45
CMFM4254N0	477	524	42	54	2.3	46	4.99
CMFM4260N0	507	553	42	60	2.3	51	5.52
CMFM4824N0	309	340	48	24	2.3	26	2.73
CMFM4830N0	350	380	48	30	2.3	33	3.37
CMFM4836N0	398	443	48	36	2.3	39	4.00
CMFM4842N0	454	514	48	42	2.3	46	4.63
CMFM4848N0	490	551	48	48	2.3	52	5.26
CMFM4854N0	539	596	48	54	2.3	59	5.89
CMFM4860N0	570	630	48	60	2.3	65	6.53
CMFM5424N0	309	340	54	24	2.3	26	2.73
CMFM5430N0	350	380	54	30	2.3	33	3.37
CMFM5436N0	398	443	54	36	2.3	39	4.00
CMFM5442N0	454	514	54	42	2.3	46	4.63
CMFM5448N0	490	551	54	48	2.3	52	5.26
CMFM5454N0	539	596	54	54	2.3	59	5.89
CMFM5460N0	570	630	54	60	2.3	65	6.53
CMFM6624N0	354	396	66	24	2.3	32	3.58
CMFM6630N0	412	452	66	30	2.3	40	4.40
CMFM6636N0	503	578	66	36	2.3	48	5.23
CMFM6642N0	555	631	66	42	2.3	56	6.06
CMFM6648N0	575	652	66	48	2.3	64	6.88
CMFM6654N0	591	666	66	54	2.3	72	7.71
CMFM6660N0	609	686	66	60	2.3	80	8.53

CMFM-N1 • Monolithic Non Powered Fabric Panel, Punchouts on One Side

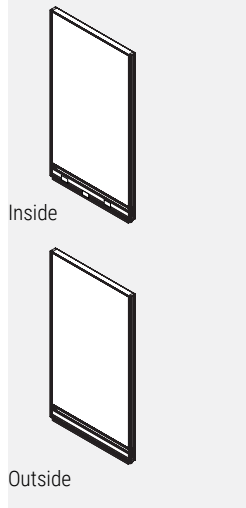

- Individual fabric-covered modules incorporated into an aluminum frame.
- Opposite sides of each module may have a different fabric within the same grade at no upcharge.
- If different grades of fabric are used on one panel, the entire panel must be priced at highest grade.
- Panels are not tackable.
- 3 Panel connector brackets per side come standard with 30" h., 42" h. and 54" h. panels.
- 4 Panel connector brackets per side come standard with 66" h. panels.
- Panels include 1 raceway cover with punchouts on one side, 1 raceway cover with no punchouts on the other, an integrated aluminum top cap and levelling glides.
- 24" wide panels have one punchout, 30" wide panels and wider have 3 punchouts.
- Note: Trim is not required at a straight connection between two panels of the same height.

PRODUCT CODE	PRICE		SIZE/ INCHES			WEIGHT VOL	
	GR 1	GR 2	H	W	D	LBS	FT ³
CMFM3024N1	271	298	30	24	2.3	20	2.31
CMFM3030N1	336	363	30	30	2.3	25	2.85
CMFM3036N1	365	412	30	36	2.3	31	3.38
CMFM3042N1	399	450	30	42	2.3	36	3.92
CMFM3048N1	433	483	30	48	2.3	41	4.45
CMFM3054N1	477	524	30	54	2.3	46	4.99
CMFM3060N1	507	553	30	60	2.3	51	5.52
CMFM4224N1	271	298	42	24	2.3	20	2.31
CMFM4230N1	336	363	42	30	2.3	25	2.85
CMFM4236N1	365	412	42	36	2.3	31	3.38
CMFM4242N1	399	450	42	42	2.3	36	3.92
CMFM4248N1	433	483	42	48	2.3	41	4.45
CMFM4254N1	477	524	42	54	2.3	46	4.99
CMFM4260N1	507	553	42	60	2.3	51	5.52
CMFM4824N1	309	340	48	24	2.3	26	2.73
CMFM4830N1	350	380	48	30	2.3	33	3.37
CMFM4836N1	398	443	48	36	2.3	39	4.00
CMFM4842N1	454	514	48	42	2.3	46	4.63
CMFM4848N1	490	551	48	48	2.3	52	5.26
CMFM4854N1	539	596	48	54	2.3	59	5.89
CMFM4860N1	570	630	48	60	2.3	65	6.53
CMFM5424N1	309	340	54	24	2.3	26	2.73
CMFM5430N1	350	380	54	30	2.3	33	3.37
CMFM5436N1	398	443	54	36	2.3	39	4.00
CMFM5442N1	454	514	54	42	2.3	46	4.63
CMFM5448N1	490	551	54	48	2.3	52	5.26
CMFM5454N1	539	596	54	54	2.3	59	5.89
CMFM5460N1	570	630	54	60	2.3	65	6.53
CMFM6624N1	354	396	66	24	2.3	32	3.58
CMFM6630N1	412	452	66	30	2.3	40	4.40
CMFM6636N1	503	578	66	36	2.3	48	5.23
CMFM6642N1	555	631	66	42	2.3	56	6.06
CMFM6648N1	575	652	66	48	2.3	64	6.88
CMFM6654N1	591	666	66	54	2.3	72	7.71
CMFM6660N1	609	686	66	60	2.3	80	8.53

CMFM-N2 • Monolithic Non Powered Fabric Panel, Punchouts on Both Sides

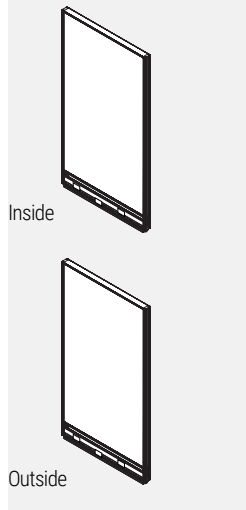

- Individual fabric-covered modules incorporated into an aluminum frame.
- Opposite sides of each module may have a different fabric within the same grade at no upcharge.
- If different grades of fabric are used on one panel, the entire panel must be priced at highest grade.
- Panels are not tackable.
- 3 Panel connector brackets per side come standard with 30”h., 42”h. and 54”h. panels.
- 4 Panel connector brackets per side come standard with 66”h. panels.
- Panels include 2 raceway covers with punchouts on both sides, an integrated aluminum top cap and levelling glides.
- 24” wide panels have two punchouts, one for electrical and one for data.
- 30” wide panels and wider have three punchouts, two for electrical and one for data.
- Note: Trim is not required at a straight connection between two panels of the same height.

PRODUCT CODE	PRICE		SIZE/ INCHES			WEIGHT VOL	
	GR 1	GR 2	H	W	D	LBS	FT ³
CMFM3024N2	271	298	30	24	2.3	20	2.31
CMFM3030N2	336	363	30	30	2.3	25	2.85
CMFM3036N2	365	412	30	36	2.3	31	3.38
CMFM3042N2	399	450	30	42	2.3	36	3.92
CMFM3048N2	433	483	30	48	2.3	41	4.45
CMFM3054N2	477	524	30	54	2.3	46	4.99
CMFM3060N2	507	553	30	60	2.3	51	5.52
CMFM4224N2	271	298	42	24	2.3	20	2.31
CMFM4230N2	336	363	42	30	2.3	25	2.85
CMFM4236N2	365	412	42	36	2.3	31	3.38
CMFM4242N2	399	450	42	42	2.3	36	3.92
CMFM4248N2	433	483	42	48	2.3	41	4.45
CMFM4254N2	477	524	42	54	2.3	46	4.99
CMFM4260N2	507	553	42	60	2.3	51	5.52
CMFM4824N2	309	340	48	24	2.3	26	2.73
CMFM4830N2	350	380	48	30	2.3	33	3.37
CMFM4836N2	398	443	48	36	2.3	39	4.00
CMFM4842N2	454	514	48	42	2.3	46	4.63
CMFM4848N2	490	551	48	48	2.3	52	5.26
CMFM4854N2	539	596	48	54	2.3	59	5.89
CMFM4860N2	570	630	48	60	2.3	65	6.53
CMFM5424N2	309	340	54	24	2.3	26	2.73
CMFM5430N2	350	380	54	30	2.3	33	3.37
CMFM5436N2	398	443	54	36	2.3	39	4.00
CMFM5442N2	454	514	54	42	2.3	46	4.63
CMFM5448N2	490	551	54	48	2.3	52	5.26
CMFM5454N2	539	596	54	54	2.3	59	5.89
CMFM5460N2	570	630	54	60	2.3	65	6.53
CMFM6624N2	354	396	66	24	2.3	32	3.58
CMFM6630N2	412	452	66	30	2.3	40	4.40
CMFM6636N2	503	578	66	36	2.3	48	5.23
CMFM6642N2	555	631	66	42	2.3	56	6.06
CMFM6648N2	575	652	66	48	2.3	64	6.88
CMFM6654N2	591	666	66	54	2.3	72	7.71
CMFM6660N2	609	686	66	60	2.3	80	8.53

CMFM-P1 • Monolithic Fabric Panel with Power Distribution Housing, Punchouts on One Side

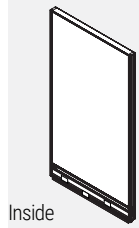

Inside

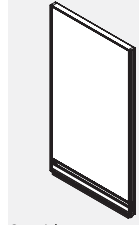

Outside

- Individual fabric-covered modules incorporated into an aluminum frame.
- Opposite sides of each module may have a different fabric within the same grade at no upcharge.
- If different grades of fabric are used on one panel, the entire panel must be priced at highest grade.
- Panels are not tackable.
- 3 Panel connector brackets per side come standard with 30"h., 42"h. and 54"h. panels.
- 4 Panel connector brackets per side come standard with 66"h. panels.
- Panels include 1 raceway cover with punchouts on one side, 1 raceway cover with no punchouts on the other, a power distribution housing, an integrated aluminum top cap and levelling glides.
- 24" wide panels have two punchouts, one for electrical and one for data.
- 30" wide panels and wider have three punchouts, two for electrical and one for data.
- Note: Trim is not required at a straight connection between two panels of the same height.
- Please specify duplex receptacles separately.

PRODUCT CODE	PRICE		SIZE/ INCHES			WEIGHT VOL	
	GR 1	GR 2	H	W	D	LBS	FT ³
CMFM3024P1	410	435	30	24	2.3	20	2.31
CMFM3030P1	521	547	30	30	2.3	25	2.85
CMFM3036P1	561	609	30	36	2.3	31	3.38
CMFM3042P1	603	653	30	42	2.3	36	3.92
CMFM3048P1	647	695	30	48	2.3	41	4.45
CMFM3054P1	693	745	30	54	2.3	46	4.99
CMFM3060P1	723	775	30	60	2.3	51	5.52
CMFM4224P1	410	435	42	24	2.3	20	2.31
CMFM4230P1	521	547	42	30	2.3	25	2.85
CMFM4236P1	561	609	42	36	2.3	31	3.38
CMFM4242P1	603	653	42	42	2.3	36	3.92
CMFM4248P1	647	695	42	48	2.3	41	4.45
CMFM4254P1	693	745	42	54	2.3	46	4.99
CMFM4260P1	723	775	42	60	2.3	51	5.52
CMFM4824P1	449	478	48	24	2.3	26	2.73
CMFM4830P1	539	568	48	30	2.3	33	3.37
CMFM4836P1	593	639	48	36	2.3	39	4.00
CMFM4842P1	656	717	48	42	2.3	46	4.63
CMFM4848P1	707	765	48	48	2.3	52	5.26
CMFM4854P1	754	814	48	54	2.3	59	5.89
CMFM4860P1	788	850	48	60	2.3	65	6.53
CMFM5424P1	449	478	54	24	2.3	26	2.73
CMFM5430P1	539	568	54	30	2.3	33	3.37
CMFM5436P1	593	639	54	36	2.3	39	4.00
CMFM5442P1	656	717	54	42	2.3	46	4.63
CMFM5448P1	707	765	54	48	2.3	52	5.26
CMFM5454P1	754	814	54	54	2.3	59	5.89
CMFM5460P1	788	850	54	60	2.3	65	6.53
CMFM6624P1	494	536	66	24	2.3	32	3.58
CMFM6630P1	602	639	66	30	2.3	40	4.40
CMFM6636P1	697	775	66	36	2.3	48	5.23
CMFM6642P1	758	833	66	42	2.3	56	6.06
CMFM6648P1	788	864	66	48	2.3	64	6.88
CMFM6654P1	809	884	66	54	2.3	72	7.71
CMFM6660P1	827	903	66	60	2.3	80	8.53

CMFM-P2 • Monolithic Fabric Panel with Power Distribution Housing, Punchouts on Both Sides

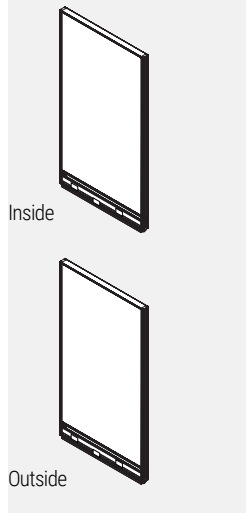

- Individual fabric-covered modules incorporated into an aluminum frame.
- Opposite sides of each module may have a different fabric within the same grade at no upcharge.
- If different grades of fabric are used on one panel, the entire panel must be priced at highest grade.
- Panels are not tackable.
- 3 Panel connector brackets per side come standard with 30”h., 42”h. and 54”h. panels.
- 4 Panel connector brackets per side come standard with 66”h. panels.
- Panels include 2 raceway covers with punchouts on both sides, a power distribution housing, an integrated aluminum top cap and levelling glides.
- 24” wide panels have two punchouts, one for electrical and one for data.
- 30” wide panels and wider have three punchouts, two for electrical and one for data.
- Note: Trim is not required at a straight connection between two panels of the same height.
- Please specify duplex receptacles separately.

PRODUCT CODE	PRICE		SIZE/ INCHES			WEIGHT VOL	
	GR 1	GR 2	H	W	D	LBS	FT³
CMFM3024P2	410	435	30	24	2.3	20	2.31
CMFM3030P2	521	547	30	30	2.3	25	2.85
CMFM3036P2	561	609	30	36	2.3	31	3.38
CMFM3042P2	603	653	30	42	2.3	36	3.92
CMFM3048P2	647	695	30	48	2.3	41	4.45
CMFM3054P2	693	745	30	54	2.3	46	4.99
CMFM3060P2	723	775	30	60	2.3	51	5.52
CMFM4224P2	410	435	42	24	2.3	20	2.31
CMFM4230P2	521	547	42	30	2.3	25	2.85
CMFM4236P2	561	609	42	36	2.3	31	3.38
CMFM4242P2	603	653	42	42	2.3	36	3.92
CMFM4248P2	647	695	42	48	2.3	41	4.45
CMFM4254P2	693	745	42	54	2.3	46	4.99
CMFM4260P2	723	775	42	60	2.3	51	5.52
CMFM4824P2	449	478	48	24	2.3	26	2.73
CMFM4830P2	539	568	48	30	2.3	33	3.37
CMFM4836P2	593	639	48	36	2.3	39	4.00
CMFM4842P2	656	717	48	42	2.3	46	4.63
CMFM4848P2	707	765	48	48	2.3	52	5.26
CMFM4854P2	754	814	48	54	2.3	59	5.89
CMFM4860P2	788	850	48	60	2.3	65	6.53
CMFM5424P2	449	478	54	24	2.3	26	2.73
CMFM5430P2	539	568	54	30	2.3	33	3.37
CMFM5436P2	593	639	54	36	2.3	39	4.00
CMFM5442P2	656	717	54	42	2.3	46	4.63
CMFM5448P2	707	765	54	48	2.3	52	5.26
CMFM5454P2	754	814	54	54	2.3	59	5.89
CMFM5460P2	788	850	54	60	2.3	65	6.53
CMFM6624P2	494	536	66	24	2.3	32	3.58
CMFM6630P2	602	639	66	30	2.3	40	4.40
CMFM6636P2	697	775	66	36	2.3	48	5.23
CMFM6642P2	758	833	66	42	2.3	56	6.06
CMFM6648P2	788	864	66	48	2.3	64	6.88
CMFM6654P2	809	884	66	54	2.3	72	7.71
CMFM6660P2	827	903	66	60	2.3	80	8.53

CMLFM-N0 • Monolithic Non Powered Laminate One Side, Fabric One Side Panel, No Punchouts

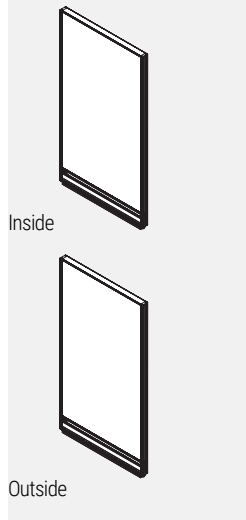

- Individual modules, one in fabric and one in laminate, incorporated into an aluminum frame.
- Panels are not tackable.
- 3 panel connector brackets per side come standard with 30”h., 42”h., and 54”h. panels.
- 4 panel connector brackets per side come standard with 66”h. panels.
- Panels include 2 raceway covers with no punchouts, an integrated aluminum top cap and levelling glides.
- Note: Trim is not required at a straight connection between two panels of the same height.

PRODUCT CODE	PRICE		SIZE/ INCHES			WEIGHT VOL	
	GR 1	GR 2	H	W	D	LBS	FT³
CMLFM3024N0	391	399	30	24	2.3	20	2.31
CMLFM3030N0	456	469	30	30	2.3	25	2.85
CMLFM3036N0	520	535	30	36	2.3	31	3.38
CMLFM3042N0	591	604	30	42	2.3	36	3.92
CMLFM3048N0	639	654	30	48	2.3	41	4.45
CMLFM3054N0	713	725	30	54	2.3	46	4.99
CMLFM3060N0	770	794	30	60	2.3	51	5.52
CMLFM4224N0	464	477	42	24	2.3	20	2.31
CMLFM4230N0	542	553	42	30	2.3	25	2.85
CMLFM4236N0	623	641	42	36	2.3	31	3.38
CMLFM4242N0	707	724	42	42	2.3	36	3.92
CMLFM4248N0	766	788	42	48	2.3	41	4.45
CMLFM4254N0	853	877	42	54	2.3	46	4.99
CMLFM4260N0	935	960	42	60	2.3	51	5.52
CMLFM4824N0	550	573	48	24	2.3	26	2.73
CMLFM4830N0	647	665	48	30	2.3	33	3.37
CMLFM4836N0	741	762	48	36	2.3	39	4.00
CMLFM4842N0	839	863	48	42	2.3	46	4.63
CMLFM4848N0	917	943	48	48	2.3	52	5.26
CMLFM4854N0	1021	1052	48	54	2.3	59	5.89
CMLFM5424N0	550	573	54	24	2.3	65	6.53
CMLFM5430N0	647	665	54	30	2.3	33	3.37
CMLFM5436N0	741	762	54	36	2.3	39	4.00
CMLFM5442N0	839	863	54	42	2.3	46	4.63
CMLFM5448N0	917	943	54	48	2.3	52	5.26
CMLFM5454N0	1021	1052	54	54	2.3	59	5.89
CMLFM6624N0	683	699	66	24	2.3	32	3.58
CMLFM6630N0	796	820	66	30	2.3	40	4.40
CMLFM6636N0	918	947	66	36	2.3	48	5.23
CMLFM6642N0	1046	1078	66	42	2.3	56	6.06
CMLFM6648N0	1139	1174	66	48	2.3	64	6.68

CMLFM-N1 • Monolithic Non Powered Laminate One Side, Fabric Other, Punchouts on One Side

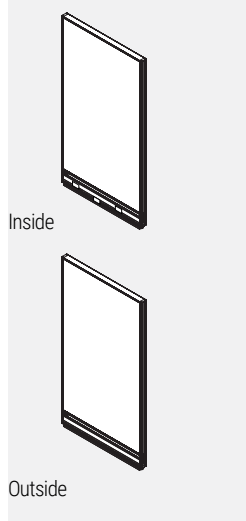

- Individual modules, one in fabric and one in laminate, incorporated into an aluminum frame.
- Panels are not tackable.
- 3 panel connector brackets per side come standard with 30”h., 42”h., and 54”h. panels.
- 4 panel connector brackets per side come standard with 66”h. panels.
- Panels include 1 raceway cover with punchouts on one side, 1 raceway cover with no punchouts on the other, an integrated aluminum top cap and levelling glides.
- 24” wide panels have two punchouts, one for electrical and one for data.
- 30” wide panels and wider have three punchouts, two for electrical and one for data.
- Note: Trim is not required at a straight connection between two panels of the same height.

PRODUCT CODE	PRICE		SIZE/ INCHES			WEIGHT VOL	
	GR 1	GR 2	H	W	D	LBS	FT³
CMLFM3024N1	391	399	30	24	2.3	20	2.31
CMLFM3030N1	456	469	30	30	2.3	25	2.85
CMLFM3036N1	520	535	30	36	2.3	31	3.38
CMLFM3042N1	591	604	30	42	2.3	36	3.92
CMLFM3048N1	639	654	30	48	2.3	41	4.45
CMLFM3054N1	713	725	30	54	2.3	46	4.99
CMLFM3060N1	770	794	30	60	2.3	51	5.52
CMLFM4224N1	464	477	42	24	2.3	20	2.31
CMLFM4230N1	542	553	42	30	2.3	25	2.85
CMLFM4236N1	623	641	42	36	2.3	31	3.38
CMLFM4242N1	707	724	42	42	2.3	36	3.92
CMLFM4248N1	766	788	42	48	2.3	41	4.45
CMLFM4254N1	853	877	42	54	2.3	46	4.99
CMLFM4260N1	935	960	42	60	2.3	51	5.52
CMLFM4824N1	550	573	48	24	2.3	26	2.73
CMLFM4830N1	647	665	48	30	2.3	33	3.37
CMLFM4836N1	741	762	48	36	2.3	39	4.00
CMLFM4842N1	839	863	48	42	2.3	46	4.63
CMLFM4848N1	917	943	48	48	2.3	52	5.26
CMLFM4854N1	1021	1052	48	54	2.3	59	5.89
CMLFM5424N1	550	573	54	24	2.3	65	6.53
CMLFM5430N1	647	665	54	30	2.3	33	3.37
CMLFM5436N1	741	762	54	36	2.3	39	4.00
CMLFM5442N1	839	863	54	42	2.3	46	4.63
CMLFM5448N1	917	943	54	48	2.3	52	5.26
CMLFM5454N1	1021	1052	54	54	2.3	59	5.89
CMLFM6624N1	683	699	66	24	2.3	32	3.58
CMLFM6630N1	796	820	66	30	2.3	40	4.40
CMLFM6636N1	918	947	66	36	2.3	48	5.23
CMLFM6642N1	1046	1078	66	42	2.3	56	6.06
CMLFM6648N1	1139	1174	66	48	2.3	64	6.68

CMLFM-N2 • Monolithic Non Powered Laminate 1 Side, Fabric Other Panel, Punchouts on Both Sides

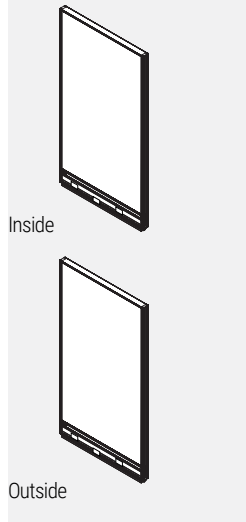

- Individual modules, one in fabric and one in laminate, incorporated into an aluminum frame.
- Panels are not tackable.
- 3 panel connector brackets per side come standard with 30”h., 42”h., and 54”h. panels.
- 4 panel connector brackets per side come standard with 66”h. panels.
- Panels include 2 raceway covers with punchouts, an integrated aluminum top cap and levelling glides.
- 24” wide panels have two punchouts, one for electrical and one for data.
- 30” wide panels and wider have three punchouts, two for electrical and one for data.
- Note: Trim is not required at a straight connection between two panels of the same height.

PRODUCT CODE	PRICE		SIZE/ INCHES			WEIGHT VOL	
	GR 1	GR 2	H	W	D	LBS	FT³
CMLFM3024N2	391	399	30	24	2.3	20	2.31
CMLFM3030N2	456	469	30	30	2.3	25	2.85
CMLFM3036N2	520	535	30	36	2.3	31	3.38
CMLFM3042N2	591	604	30	42	2.3	36	3.92
CMLFM3048N2	639	654	30	48	2.3	41	4.45
CMLFM3054N2	713	725	30	54	2.3	46	4.99
CMLFM3060N2	770	794	30	60	2.3	51	5.52
CMLFM4224N2	464	477	42	24	2.3	20	2.31
CMLFM4230N2	542	553	42	30	2.3	25	2.85
CMLFM4236N2	623	641	42	36	2.3	31	3.38
CMLFM4242N2	707	724	42	42	2.3	36	3.92
CMLFM4248N2	766	788	42	48	2.3	41	4.45
CMLFM4254N2	853	877	42	54	2.3	46	4.99
CMLFM4260N2	935	960	42	60	2.3	51	5.52
CMLFM4824N2	550	573	48	24	2.3	26	2.73
CMLFM4830N2	647	665	48	30	2.3	33	3.37
CMLFM4836N2	741	762	48	36	2.3	39	4.00
CMLFM4842N2	839	863	48	42	2.3	46	4.63
CMLFM4848N2	917	943	48	48	2.3	52	5.26
CMLFM4854N2	1021	1052	48	54	2.3	59	5.89
CMLFM5424N2	550	573	54	24	2.3	65	6.53
CMLFM5430N2	647	665	54	30	2.3	33	3.37
CMLFM5436N2	741	762	54	36	2.3	39	4.00
CMLFM5442N2	839	863	54	42	2.3	46	4.63
CMLFM5448N2	917	943	54	48	2.3	52	5.26
CMLFM5454N2	1021	1052	54	54	2.3	59	5.89
CMLFM6624N2	683	699	66	24	2.3	32	3.58
CMLFM6630N2	796	820	66	30	2.3	40	4.40
CMLFM6636N2	918	947	66	36	2.3	48	5.23
CMLFM6642N2	1046	1078	66	42	2.3	56	6.06
CMLFM6648N2	1139	1174	66	48	2.3	64	6.68

CMLFM-P1 • Monolithic Laminate One Side, Fabric Other Side Panel with PDH, Punchouts on One Side

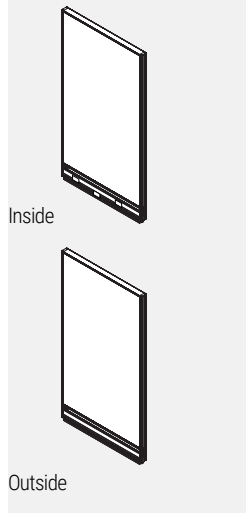

- Individual modules, one in fabric and one in laminate, incorporated into an aluminum frame.
- Panels are not tackable.
- 3 panel connector brackets per side come standard with 30”h., 42”h., and 54”h. panels.
- 4 panel connector brackets per side come standard with 66”h. panels.
- Panels include 1 raceway cover with punchouts on one side, 1 raceway cover with no punchouts on the other, a power distribution housing, an integrated aluminum top cap and levelling glides.
- 24” wide panels have two punchouts, one for electrical and one for data.
- 30” wide panels and wider have three punchouts, two for electrical and one for data.
- Note: Trim is not required at a straight connection between two panels of the same height.
- Please specify duplex receptacles separately.

PRODUCT CODE	PRICE		SIZE/ INCHES			WEIGHT VOL	
	GR 1	GR 2	H	W	D	LBS	FT³
CMLFM3024P1	522	535	30	24	2.3	20	2.31
CMLFM3030P1	645	655	30	30	2.3	25	2.85
CMLFM3036P1	713	720	30	36	2.3	31	3.38
CMLFM3042P1	784	796	30	42	2.3	36	3.92
CMLFM3048P1	843	856	30	48	2.3	41	4.45
CMLFM3054P1	918	933	30	54	2.3	46	4.99
CMLFM3060P1	986	1001	30	60	2.3	51	5.52
CMLFM4224P1	596	609	42	24	2.3	20	2.31
CMLFM4230P1	720	733	42	30	2.3	25	2.85
CMLFM4236P1	811	827	42	36	2.3	31	3.38
CMLFM4242P1	897	918	42	42	2.3	36	3.92
CMLFM4248P1	971	994	42	48	2.3	41	4.45
CMLFM4254P1	1061	1084	42	54	2.3	46	4.99
CMLFM4260P1	1143	1169	42	60	2.3	51	5.52
CMLFM4824P1	683	697	48	24	2.3	26	2.73
CMLFM4830P1	825	843	48	30	2.3	33	3.37
CMLFM4836P1	928	951	48	36	2.3	39	4.00
CMLFM4842P1	1030	1056	48	42	2.3	46	4.63
CMLFM4848P1	1121	1147	48	48	2.3	52	5.26
CMLFM4854P1	1171	1226	48	54	2.3	59	5.89
CMLFM5424P1	683	697	54	24	2.3	65	6.53
CMLFM5430P1	825	843	54	30	2.3	33	3.37
CMLFM5436P1	928	951	54	36	2.3	39	4.00
CMLFM5442P1	1030	1056	54	42	2.3	46	4.63
CMLFM5448P1	1121	1147	54	48	2.3	52	5.26
CMLFM5454P1	1226	1259	54	54	2.3	59	5.89
CMLFM6624P1	816	833	66	24	2.3	32	3.58
CMLFM6630P1	973	998	66	30	2.3	40	4.40
CMLFM6636P1	1106	1132	66	36	2.3	48	5.23
CMLFM6642P1	1238	1269	66	42	2.3	56	6.06
CMLFM6648P1	1343	1378	66	48	2.3	64	6.68

CMLFM-P2 • Monolithic Laminate One Side, Fabric Other Panel with PDH, Punchouts on Both Side

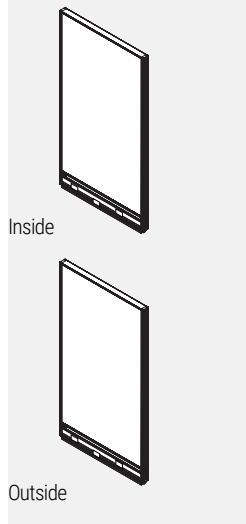

- Individual modules, one in fabric and one in laminate, incorporated into an aluminum frame.
- Panels are not tackable.
- 3 panel connector brackets per side come standard with 30”h., 42”h., and 54”h. panels.
- 4 panel connector brackets per side come standard with 66”h. panels.
- Panels include 2 raceway cover with punchouts, a power distribution housing, an integrated aluminum top cap and levelling glides.
- 24” wide panels have two punchouts, one for electrical and one for data.
- 30” wide panels and wider have three punchouts, two for electrical and one for data.
- Note: Trim is not required at a straight connection between two panels of the same height.
- Please specify duplex receptacles separately.

PRODUCT CODE	PRICE		SIZE/ INCHES			WEIGHT VOL	
	GR 1	GR 2	H	W	D	LBS	FT³
CMLFM3024P2	522	535	30	24	2.3	20	2.31
CMLFM3030P2	645	655	30	30	2.3	25	2.85
CMLFM3036P2	713	720	30	36	2.3	31	3.38
CMLFM3042P2	784	796	30	42	2.3	36	3.92
CMLFM3048P2	843	856	30	48	2.3	41	4.45
CMLFM3054P2	918	933	30	54	2.3	46	4.99
CMLFM3060P2	986	1001	30	60	2.3	51	5.52
CMLFM4224P2	596	609	42	24	2.3	20	2.31
CMLFM4230P2	720	733	42	30	2.3	25	2.85
CMLFM4236P2	811	827	42	36	2.3	31	3.38
CMLFM4242P2	897	918	42	42	2.3	36	3.92
CMLFM4248P2	971	994	42	48	2.3	41	4.45
CMLFM4254P2	1061	1084	42	54	2.3	46	4.99
CMLFM4260P2	1143	1169	42	60	2.3	51	5.52
CMLFM4824P2	683	697	48	24	2.3	26	2.73
CMLFM4830P2	825	843	48	30	2.3	33	3.37
CMLFM4836P2	928	951	48	36	2.3	39	4.00
CMLFM4842P2	1030	1056	48	42	2.3	46	4.63
CMLFM4848P2	1121	1147	48	48	2.3	52	5.26
CMLFM4854P2	1171	1226	48	54	2.3	59	5.89
CMLFM5424P2	683	697	54	24	2.3	65	6.53
CMLFM5430P2	825	843	54	30	2.3	33	3.37
CMLFM5436P2	928	951	54	36	2.3	39	4.00
CMLFM5442P2	1030	1056	54	42	2.3	46	4.63
CMLFM5448P2	1121	1147	54	48	2.3	52	5.26
CMLFM5454P2	1226	1259	54	54	2.3	59	5.89
CMLFM6624P2	816	833	66	24	2.3	32	3.58
CMLFM6630P2	973	998	66	30	2.3	40	4.40
CMLFM6636P2	1106	1132	66	36	2.3	48	5.23
CMLFM6642P2	1238	1269	66	42	2.3	56	6.06
CMLFM6648P2	1343	1378	66	48	2.3	64	6.68

CMLLM-N0 • Monolithic Non Powered Laminate Two Sides Panel, No Punchouts

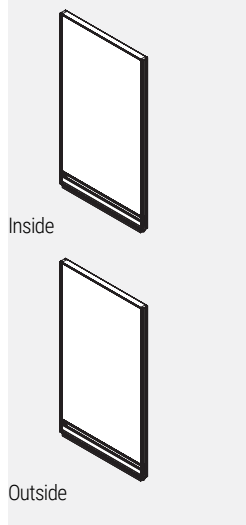

- Individual laminate modules incorporated into an aluminum frame.
- Panels are not tackable.
- 3 panel connector brackets per side come standard with 30”h., 42”h., and 54”h. panels.
- 4 panel connector brackets per side come standard with 66”h. panels.
- Panels include 2 raceway covers with no punchouts, an integrated aluminum top cap and levelling glides.
- Note: Trim is not required at a straight connection between two panels of the same height.

PRODUCT CODE	PRICE		SIZE/ INCHES			WEIGHT VOL	
	GR 1	GR 2	H	W	D	LBS	FT³
CMLLM3024N0	448		30	24	2.3	20	2.31
CMLLM3030N0	527		30	30	2.3	25	2.85
CMLLM3036N0	604		30	36	2.3	31	3.38
CMLLM3042N0	687		30	42	2.3	36	3.92
CMLLM3048N0	766		30	48	2.3	41	4.45
CMLLM3054N0	850		30	54	2.3	46	4.99
CMLLM3060N0	918		30	60	2.3	51	5.52
CMLLM4224N0	527		42	24	2.3	20	2.31
CMLLM4230N0	622		42	30	2.3	25	2.85
CMLLM4236N0	722		42	36	2.3	31	3.38
CMLLM4242N0	825		42	42	2.3	36	3.92
CMLLM4248N0	922		42	48	2.3	41	4.45
CMLLM4254N0	1017		42	54	2.3	46	4.99
CMLLM4260N0	1107		42	60	2.3	51	5.52
CMLLM4824N0	625		48	24	2.3	26	2.73
CMLLM4830N0	741		48	30	2.3	33	3.37
CMLLM4836N0	860		48	36	2.3	39	4.00
CMLLM4842N0	983		48	42	2.3	46	4.63
CMLLM4848N0	1107		48	48	2.3	52	5.26
CMLLM4854N0	1216		48	54	2.3	59	5.89
CMLLM5424N0	625		54	24	2.3	65	6.53
CMLLM5430N0	741		54	30	2.3	33	3.37
CMLLM5436N0	860		54	36	2.3	39	4.00
CMLLM5442N0	983		54	42	2.3	46	4.63
CMLLM5448N0	1107		54	48	2.3	52	5.26
CMLLM5454N0	1216		54	54	2.3	59	5.89
CMLLM6624N0	788		66	24	2.3	32	3.58
CMLLM6630N0	935		66	30	2.3	40	4.40
CMLLM6636N0	1087		66	36	2.3	48	5.23
CMLLM6642N0	1244		66	42	2.3	56	6.06
CMLLM6648N0	1395		66	48	2.3	64	6.68

CMLLM-N1 • Monolithic Non Powered Laminate Two Sides Panel, Punchouts on One Side

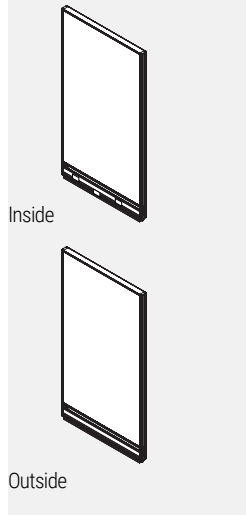

- Individual laminate modules incorporated into an aluminum frame.
- Panels are not tackable.
- 3 panel connector brackets per side come standard with 30”h., 42”h., and 54”h. panels.
- 4 panel connector brackets per side come standard with 66”h. panels.
- Panels include 1 raceway cover with punchouts on one side, 1 raceway cover with no punchouts on the other, an integrated aluminum top cap and levelling glides.
- 24” wide panels have two punchouts, one for electrical and one for data.
- 30” wide panels and wider have three punchouts, two for electrical and one for data.
- Note: Trim is not required at a straight connection between two panels of the same height.

PRODUCT CODE	PRICE	SIZE/ INCHES			WEIGHT VOL	
		H	W	D	LBS	FT³
CMLLM3024N1	448	30	24	2.3	20	2.31
CMLLM3030N1	527	30	30	2.3	25	2.85
CMLLM3036N1	604	30	36	2.3	31	3.38
CMLLM3042N1	687	30	42	2.3	36	3.92
CMLLM3048N1	766	30	48	2.3	41	4.45
CMLLM3054N1	850	30	54	2.3	46	4.99
CMLLM3060N1	918	30	60	2.3	51	5.52
CMLLM4224N1	527	42	24	2.3	20	2.31
CMLLM4230N1	622	42	30	2.3	25	2.85
CMLLM4236N1	722	42	36	2.3	31	3.38
CMLLM4242N1	825	42	42	2.3	36	3.92
CMLLM4248N1	922	42	48	2.3	41	4.45
CMLLM4254N1	1017	42	54	2.3	46	4.99
CMLLM4260N1	1107	42	60	2.3	51	5.52
CMLLM4824N1	625	48	24	2.3	26	2.73
CMLLM4830N1	741	48	30	2.3	33	3.37
CMLLM4836N1	860	48	36	2.3	39	4.00
CMLLM4842N1	983	48	42	2.3	46	4.63
CMLLM4848N1	1107	48	48	2.3	52	5.26
CMLLM4854N1	1216	48	54	2.3	59	5.89
CMLLM5424N1	625	54	24	2.3	65	6.53
CMLLM5430N1	741	54	30	2.3	33	3.37
CMLLM5436N1	860	54	36	2.3	39	4.00
CMLLM5442N1	983	54	42	2.3	46	4.63
CMLLM5448N1	1107	54	48	2.3	52	5.26
CMLLM5454N1	1216	54	54	2.3	59	5.89
CMLLM6624N1	788	66	24	2.3	32	3.58
CMLLM6630N1	935	66	30	2.3	40	4.40
CMLLM6636N1	1087	66	36	2.3	48	5.23
CMLLM6642N1	1244	66	42	2.3	56	6.06
CMLLM6648N1	1395	66	48	2.3	64	6.68

CMLLM-N2 • Monolithic Non Powered Laminate Two Sides Panel, Punchouts on Both Sides

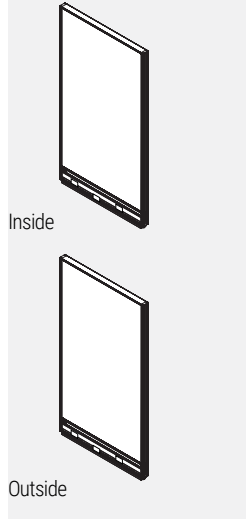

- Individual laminate modules incorporated into an aluminum frame.
- Panels are not tackable.
- 3 panel connector brackets per side come standard with 30”h., 42”h., and 54”h. panels.
- 4 panel connector brackets per side come standard with 66”h. panels.
- Panels include 2 raceway covers with punchouts, an integrated aluminum top cap and levelling glides.
- 24” wide panels have two punchouts, one for electrical and one for data.
- 30” wide panels and wider have three punchouts, two for electrical and one for data.
- Note: Trim is not required at a straight connection between two panels of the same height.

PRODUCT CODE	PRICE	SIZE/ INCHES			WEIGHT VOL	
		H	W	D	LBS	FT³
CMLLM3024N2	448	30	24	2.3	20	2.31
CMLLM3030N2	527	30	30	2.3	25	2.85
CMLLM3036N2	604	30	36	2.3	31	3.38
CMLLM3042N2	687	30	42	2.3	36	3.92
CMLLM3048N2	766	30	48	2.3	41	4.45
CMLLM3054N2	850	30	54	2.3	46	4.99
CMLLM3060N2	918	30	60	2.3	51	5.52
CMLLM4224N2	527	42	24	2.3	20	2.31
CMLLM4230N2	622	42	30	2.3	25	2.85
CMLLM4236N2	722	42	36	2.3	31	3.38
CMLLM4242N2	825	42	42	2.3	36	3.92
CMLLM4248N2	922	42	48	2.3	41	4.45
CMLLM4254N2	1017	42	54	2.3	46	4.99
CMLLM4260N2	1107	42	60	2.3	51	5.52
CMLLM4824N2	625	48	24	2.3	26	2.73
CMLLM4830N2	741	48	30	2.3	33	3.37
CMLLM4836N2	860	48	36	2.3	39	4.00
CMLLM4842N2	983	48	42	2.3	46	4.63
CMLLM4848N2	1107	48	48	2.3	52	5.26
CMLLM4854N2	1216	48	54	2.3	59	5.89
CMLLM5424N2	625	54	24	2.3	65	6.53
CMLLM5430N2	741	54	30	2.3	33	3.37
CMLLM5436N2	860	54	36	2.3	39	4.00
CMLLM5442N2	983	54	42	2.3	46	4.63
CMLLM5448N2	1107	54	48	2.3	52	5.26
CMLLM5454N2	1216	54	54	2.3	59	5.89
CMLLM6624N2	788	66	24	2.3	32	3.58
CMLLM6630N2	935	66	30	2.3	40	4.40
CMLLM6636N2	1087	66	36	2.3	48	5.23
CMLLM6642N2	1244	66	42	2.3	56	6.06
CMLLM6648N2	1395	66	48	2.3	64	6.68

CMLLM-P1 • Monolithic Laminate Two Sides Panel with PDH, Punchouts on One Side

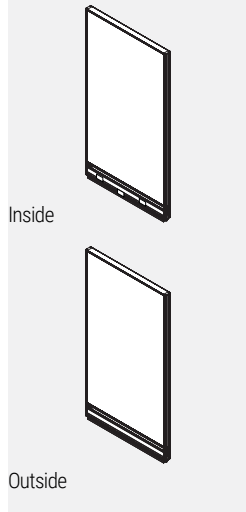

- Individual laminate modules incorporated into an aluminum frame.
- Panels are not tackable.
- 3 panel connector brackets per side come standard with 30”h., 42”h., and 54”h. panels.
- 4 panel connector brackets per side come standard with 66”h. panels.
- Panels include 1 raceway cover with punchouts on one side, 1 raceway cover with no punchouts on the other, a power distribution housing, an integrated aluminum top cap and levelling glides.
- 24” wide panels have two punchouts, one for electrical and one for data.
- 30” wide panels and wider have three punchouts, two for electrical and one for data.
- Note: Trim is not required at a straight connection between two panels of the same height.
- Please specify duplex receptacles separately.

PRODUCT CODE	PRICE	SIZE/ INCHES			WEIGHT VOL	
		H	W	D	LBS	FT³
CMLLM3024P1	579	30	24	2.3	20	2.31
CMLLM3030P1	707	30	30	2.3	25	2.85
CMLLM3036P1	790	30	36	2.3	31	3.38
CMLLM3042P1	880	30	42	2.3	36	3.92
CMLLM3048P1	971	30	48	2.3	41	4.45
CMLLM3054P1	1056	30	54	2.3	46	4.99
CMLLM3060P1	1126	30	60	2.3	51	5.52
CMLLM4224P1	659	42	24	2.3	20	2.31
CMLLM4230P1	800	42	30	2.3	25	2.85
CMLLM4236P1	909	42	36	2.3	31	3.38
CMLLM4242P1	1018	42	42	2.3	36	3.92
CMLLM4248P1	1126	42	48	2.3	41	4.45
CMLLM4254P1	1224	42	54	2.3	46	4.99
CMLLM4260P1	1315	42	60	2.3	51	5.52
CMLLM4824P1	757	48	24	2.3	26	2.73
CMLLM4830P1	918	48	30	2.3	33	3.37
CMLLM4836P1	1046	48	36	2.3	39	4.00
CMLLM4842P1	1174	48	42	2.3	46	4.63
CMLLM4848P1	1310	48	48	2.3	52	5.26
CMLLM4854P1	1424	48	54	2.3	59	5.89
CMLLM5424P1	757	54	24	2.3	65	6.53
CMLLM5430P1	918	54	30	2.3	33	3.37
CMLLM5436P1	1046	54	36	2.3	39	4.00
CMLLM5442P1	1174	54	42	2.3	46	4.63
CMLLM5448P1	1310	54	48	2.3	52	5.26
CMLLM5454P1	1424	54	54	2.3	59	5.89
CMLLM6624P1	921	66	24	2.3	32	3.58
CMLLM6630P1	1113	66	30	2.3	40	4.40
CMLLM6636P1	1272	66	36	2.3	48	5.23
CMLLM6642P1	1438	66	42	2.3	56	6.06
CMLLM6648P1	1600	66	48	2.3	64	6.68

CMLLM-P2 • Monolithic Laminate Two Sides Panel with PDH, Punchouts on Both Side

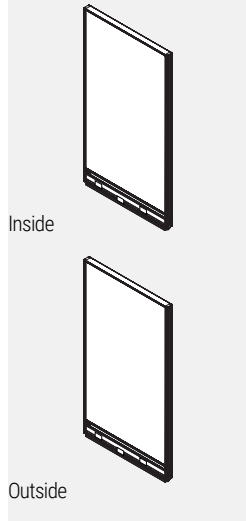

- Individual laminate modules incorporated into an aluminum frame.
- Panels are not tackable.
- 3 panel connector brackets per side come standard with 30”h., 42”h., and 54”h. panels.
- 4 panel connector brackets per side come standard with 66”h. panels.
- Panels include 2 raceway cover with punchouts, a power distribution housing, an integrated aluminum top cap and levelling glides.
- 24” wide panels have two punchouts, one for electrical and one for data.
- 30” wide panels and wider have three punchouts, two for electrical and one for data.
- Note: Trim is not required at a straight connection between two panels of the same height.
- Please specify duplex receptacles separately.

PRODUCT CODE	PRICE	SIZE/ INCHES			WEIGHT VOL	
		H	W	D	LBS	FT³
CMLLM3024P2	579	30	24	2.3	20	2.31
CMLLM3030P2	707	30	30	2.3	25	2.85
CMLLM3036P2	790	30	36	2.3	31	3.38
CMLLM3042P2	880	30	42	2.3	36	3.92
CMLLM3048P2	971	30	48	2.3	41	4.45
CMLLM3054P2	1056	30	54	2.3	46	4.99
CMLLM3060P2	1126	30	60	2.3	51	5.52
CMLLM4224P2	659	42	24	2.3	20	2.31
CMLLM4230P2	800	42	30	2.3	25	2.85
CMLLM4236P2	909	42	36	2.3	31	3.38
CMLLM4242P2	1018	42	42	2.3	36	3.92
CMLLM4248P2	1126	42	48	2.3	41	4.45
CMLLM4254P2	1224	42	54	2.3	46	4.99
CMLLM4260P2	1315	42	60	2.3	51	5.52
CMLLM4824P2	757	48	24	2.3	26	2.73
CMLLM4830P2	918	48	30	2.3	33	3.37
CMLLM4836P2	1046	48	36	2.3	39	4.00
CMLLM4842P2	1174	48	42	2.3	46	4.63
CMLLM4848P2	1310	48	48	2.3	52	5.26
CMLLM4854P2	1424	48	54	2.3	59	5.89
CMLLM5424P2	757	54	24	2.3	65	6.53
CMLLM5430P2	918	54	30	2.3	33	3.37
CMLLM5436P2	1046	54	36	2.3	39	4.00
CMLLM5442P2	1174	54	42	2.3	46	4.63
CMLLM5448P2	1310	54	48	2.3	52	5.26
CMLLM5454P2	1424	54	54	2.3	59	5.89
CMLLM6624P2	921	66	24	2.3	32	3.58
CMLLM6630P2	1113	66	30	2.3	40	4.40
CMLLM6636P2	1272	66	36	2.3	48	5.23
CMLLM6642P2	1438	66	42	2.3	56	6.06
CMLLM6648P2	1600	66	48	2.3	64	6.68

CMFF-N0 • Single Segmented Non Powered Fabric Panel, No Punchouts

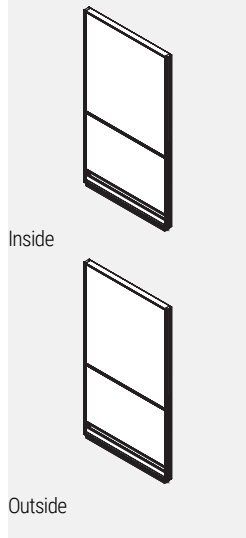

- Individual fabric-covered modules incorporated into an aluminum frame.
- Opposite sides of each module may have a different fabric within the same grade at no upcharge.
- If different grades of fabric are used on one panel, the entire panel must be priced at highest grade.
- Panels are not tackable.
- Note: Trim is not required at a straight connection between two panels of the same height.
- 3 Panel connector brackets per side come standard with 42”h. and 54”h. panels.
- 4 Panel connector brackets per side come standard with 66”h. panels.
- Panels include 2 raceway covers with no punchouts, an integrated aluminum top cap and levelling glides.

PRODUCT CODE	PRICE		SIZE/ INCHES			WEIGHT VOL	
	GR 1	GR 2	H	W	D	LBS	FT³
CMFF4224N0	295	319	42	24	2.3	20	2.31
CMFF4230N0	366	391	42	30	2.3	25	2.85
CMFF4236N0	394	443	42	36	2.3	31	3.38
CMFF4242N0	451	501	42	42	2.3	36	3.92
CMFF4248N0	482	534	42	48	2.3	41	4.45
CMFF4254N0	524	577	42	54	2.3	46	4.99
CMFF4260N0	578	627	42	60	2.3	51	5.52
CMFF4266N0	748	857	42	66	2.3	55	6.05
CMFF4272N0	786	895	42	72	2.3	60	6.60
CMFF4824N0	344	375	48	24	2.3	26	2.73
CMFF4830N0	394	422	48	30	2.3	33	3.37
CMFF4836N0	449	491	48	36	2.3	39	4.00
CMFF4842N0	514	575	48	42	2.3	46	4.63
CMFF4848N0	547	608	48	48	2.3	52	5.26
CMFF4854N0	602	659	48	54	2.3	59	5.89
CMFF4860N0	636	695	48	60	2.3	65	6.53
CMFF5424N0	344	375	54	24	2.3	26	2.73
CMFF5430N0	394	422	54	30	2.3	33	3.37
CMFF5436N0	449	491	54	36	2.3	39	4.00
CMFF5442N0	514	575	54	42	2.3	46	4.63
CMFF5448N0	547	608	54	48	2.3	52	5.26
CMFF5454N0	602	659	54	54	2.3	59	5.89
CMFF5460N0	636	695	54	60	2.3	65	6.53
CMFF6624N0	382	420	66	24	2.3	32	3.58
CMFF6630N0	425	464	66	30	2.3	40	4.40
CMFF6636N0	510	584	66	36	2.3	48	5.23
CMFF6642N0	578	654	66	42	2.3	56	6.06
CMFF6648N0	605	681	66	48	2.3	64	6.88
CMFF6654N0	660	737	66	54	2.3	72	7.71
CMFF6660N0	707	781	66	60	2.3	80	8.53

CMFF-N1 • Single Segmented Non Powered Fabric Panel, Punchouts on One Side

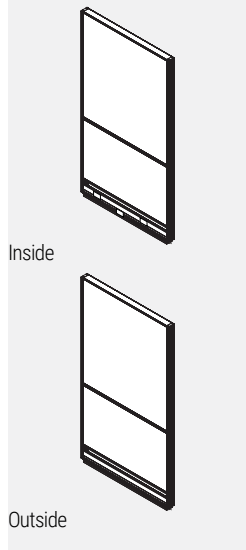

- Individual fabric-covered modules incorporated into an aluminum frame.
- Opposite sides of each module may have a different fabric within the same grade at no upcharge.
- If different grades of fabric are used on one panel, the entire panel must be priced at highest grade.
- Panels are not tackable.
- Note: Trim is not required at a straight connection between two panels of the same height.
- 3 Panel connector brackets per side come standard with 42”h. and 54”h. panels.
- 4 Panel connector brackets per side come standard with 66”h. panels.
- Panels include 1 raceway cover with punchouts on one side, 1 raceway cover with no punchouts on the other, an integrated aluminum top cap and levelling glides.
- 24” wide panels have two punchouts, one for electrical and one for data.
- 30” wide panels and wider have three punchouts, two for electrical and one for data.

PRODUCT CODE	PRICE		SIZE/ INCHES			WEIGHT VOL	
	GR 1	GR 2	H	W	D	LBS	FT³
CMFF4224N1	295	319	42	24	2.3	20	2.31
CMFF4230N1	366	391	42	30	2.3	25	2.85
CMFF4236N1	394	443	42	36	2.3	31	3.38
CMFF4242N1	451	501	42	42	2.3	36	3.92
CMFF4248N1	482	534	42	48	2.3	41	4.45
CMFF4254N1	524	577	42	54	2.3	46	4.99
CMFF4260N1	578	627	42	60	2.3	51	5.52
CMFF4266N1	748	857	42	66	2.3	55	6.05
CMFF4272N1	786	895	42	72	2.3	60	6.60
CMFF4824N1	344	375	48	24	2.3	26	2.73
CMFF4830N1	394	422	48	30	2.3	33	3.37
CMFF4836N1	449	491	48	36	2.3	39	4.00
CMFF4842N1	514	575	48	42	2.3	46	4.63
CMFF4848N1	547	608	48	48	2.3	52	5.26
CMFF4854N1	602	659	48	54	2.3	59	5.89
CMFF4860N1	636	695	48	60	2.3	65	6.53
CMFF5424N1	344	375	54	24	2.3	26	2.73
CMFF5430N1	394	422	54	30	2.3	33	3.37
CMFF5436N1	449	491	54	36	2.3	39	4.00
CMFF5442N1	514	575	54	42	2.3	46	4.63
CMFF5448N1	547	608	54	48	2.3	52	5.26
CMFF5454N1	602	659	54	54	2.3	59	5.89
CMFF5460N1	636	695	54	60	2.3	65	6.53
CMFF6624N1	382	420	66	24	2.3	32	3.58
CMFF6630N1	425	464	66	30	2.3	40	4.40
CMFF6636N1	510	584	66	36	2.3	48	5.23
CMFF6642N1	578	654	66	42	2.3	56	6.06
CMFF6648N1	605	681	66	48	2.3	64	6.88
CMFF6654N1	660	737	66	54	2.3	72	7.71
CMFF6660N1	707	781	66	60	2.3	80	8.53

CMFF-N2 • Single Segmented Non Powered Fabric Panel, Punchouts on Both Sides

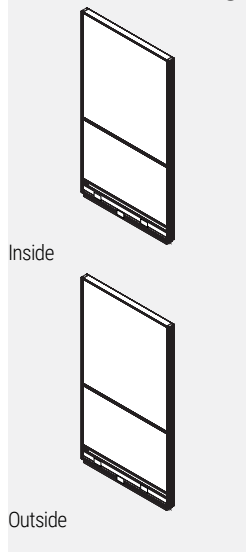

- Individual fabric-covered modules incorporated into an aluminum frame.
- Opposite sides of each module may have a different fabric within the same grade at no upcharge.
- If different grades of fabric are used on one panel, the entire panel must be priced at highest grade.
- Panels are not tackable.
- Note: Trim is not required at a straight connection between two panels of the same height.
- 3 Panel connector brackets per side come standard with 42”h. and 54”h. panels.
- 4 Panel connector brackets per side come standard with 66”h. panels.
- Panels include 2 raceway covers with punchouts on both sides, an integrated aluminum top cap and levelling glides.
- 24” wide panels have two punchouts, one for electrical and one for data.
- 30” wide panels and wider have three punchouts, two for electrical and one for data.

PRODUCT CODE	PRICE		SIZE/ H	INCHES			WEIGHT VOL	
	GR 1	GR 2		W	D	LBS	FT³	
CMFF4224N2	295	319	42	24	2.3	20	2.31	
CMFF4230N2	366	391	42	30	2.3	25	2.85	
CMFF4236N2	394	443	42	36	2.3	31	3.38	
CMFF4242N2	451	501	42	42	2.3	36	3.92	
CMFF4248N2	482	534	42	48	2.3	41	4.45	
CMFF4254N2	524	577	42	54	2.3	46	4.99	
CMFF4260N2	578	627	42	60	2.3	51	5.52	
CMFF4266N2	748	857	42	66	2.3	55	6.05	
CMFF4272N2	786	895	42	72	2.3	60	6.60	
CMFF4824N2	344	375	48	24	2.3	26	2.73	
CMFF4830N2	394	422	48	30	2.3	33	3.37	
CMFF4836N2	449	491	48	36	2.3	39	4.00	
CMFF4842N2	514	575	48	42	2.3	46	4.63	
CMFF4848N2	547	608	48	48	2.3	52	5.26	
CMFF4854N2	602	659	48	54	2.3	59	5.89	
CMFF4860N2	636	695	48	60	2.3	65	6.53	
CMFF5424N2	344	375	54	24	2.3	26	2.73	
CMFF5430N2	394	422	54	30	2.3	33	3.37	
CMFF5436N2	449	491	54	36	2.3	39	4.00	
CMFF5442N2	514	575	54	42	2.3	46	4.63	
CMFF5448N2	547	608	54	48	2.3	52	5.26	
CMFF5454N2	602	659	54	54	2.3	59	5.89	
CMFF5460N2	636	695	54	60	2.3	65	6.53	
CMFF6624N2	382	420	66	24	2.3	32	3.58	
CMFF6630N2	425	464	66	30	2.3	40	4.40	
CMFF6636N2	510	584	66	36	2.3	48	5.23	
CMFF6642N2	578	654	66	42	2.3	56	6.06	
CMFF6648N2	605	681	66	48	2.3	64	6.88	
CMFF6654N2	660	737	66	54	2.3	72	7.71	
CMFF6660N2	707	781	66	60	2.3	80	8.53	

CMFF-P1 • Single Segmented Powered Fabric Panel, Punchouts on One Side

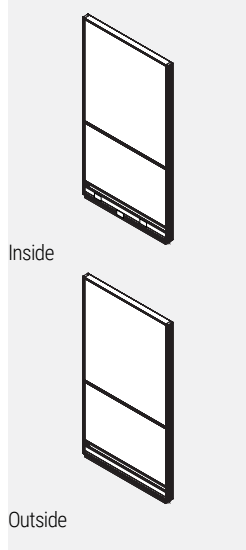

- Individual fabric-covered modules incorporated into an aluminum frame.
- Opposite sides of each module may have a different fabric within the same grade at no upcharge.
- If different grades of fabric are used on one panel, the entire panel must be priced at highest grade.
- Panels are not tackable.
- Note: Trim is not required at a straight connection between two panels of the same height.
- 3 Panel connector brackets per side come standard with 42”h. and 54”h. panels.
- 4 Panel connector brackets per side come standard with 66”h. panels.
- Panels include 1 raceway cover with punchouts on one side, 1 raceway cover with no punchouts on the other, a power distribution housing, an integrated aluminum top cap and levelling glides.
- 24” wide panels have two punchouts, one for electrical and one for data.
- 30” wide panels and wider have three punchouts, two for electrical and one for data.
- Please specify duplex receptacles separately.

PRODUCT CODE	PRICE		SIZE/ H	INCHES			WEIGHT VOL	
	GR 1	GR 2		W	D	LBS	FT³	
CMFF4224P1	433	457	42	24	2.3	20	2.31	
CMFF4230P1	551	578	42	30	2.3	25	2.85	
CMFF4236P1	590	639	42	36	2.3	31	3.38	
CMFF4242P1	654	701	42	42	2.3	36	3.92	
CMFF4248P1	694	746	42	48	2.3	41	4.45	
CMFF4254P1	745	792	42	54	2.3	46	4.99	
CMFF4260P1	796	846	42	60	2.3	51	5.52	
CMFF4266P1	975	1086	42	66	2.3	55	6.05	
CMFF4272P1	1022	1130	42	72	2.3	60	6.60	
CMFF4824P1	484	514	48	24	2.3	26	2.73	
CMFF4830P1	580	610	48	30	2.3	33	3.37	
CMFF4836P1	644	689	48	36	2.3	39	4.00	
CMFF4842P1	717	778	48	42	2.3	46	4.63	
CMFF4848P1	761	823	48	48	2.3	52	5.26	
CMFF4854P1	817	879	48	54	2.3	59	5.89	
CMFF4860P1	854	916	48	60	2.3	65	6.53	
CMFF5424P1	484	514	54	24	2.3	26	2.73	
CMFF5430P1	580	610	54	30	2.3	33	3.37	
CMFF5436P1	644	689	54	36	2.3	39	4.00	
CMFF5442P1	717	778	54	42	2.3	46	4.63	
CMFF5448P1	761	823	54	48	2.3	52	5.26	
CMFF5454P1	817	879	54	54	2.3	59	5.89	
CMFF5460P1	854	916	54	60	2.3	65	6.53	
CMFF6624P1	520	561	66	24	2.3	32	3.58	
CMFF6630P1	612	653	66	30	2.3	40	4.40	
CMFF6636P1	707	781	66	36	2.3	48	5.23	
CMFF6642P1	780	854	66	42	2.3	56	6.06	
CMFF6648P1	819	894	66	48	2.3	64	6.88	
CMFF6654P1	880	955	66	54	2.3	72	7.71	
CMFF6660P1	925	999	66	60	2.3	80	8.53	

CMFF-P2 • Single Segmented Powered Fabric Panel, Punchouts on Both Sides

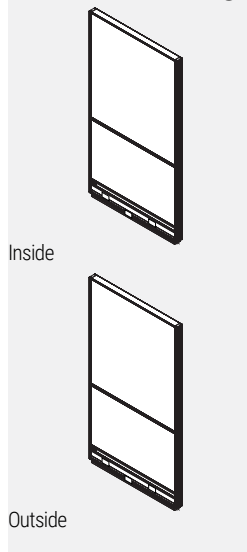

- Individual fabric-covered modules incorporated into an aluminum frame.
- Opposite sides of each module may have a different fabric within the same grade at no upcharge.
- If different grades of fabric are used on one panel, the entire panel must be priced at highest grade.
- Panels are not tackable.
- Note: Trim is not required at a straight connection between two panels of the same height.
- 3 Panel connector brackets per side come standard with 42”h. and 54”h. panels.
- 4 Panel connector brackets per side come standard with 66”h. panels.
- Panels include 2 raceway covers with punchouts on both sides, a power distribution housing, an integrated aluminum top cap and levelling glides.
- 24” wide panels have two punchouts, one for electrical and one for data.
- 30” wide panels and wider have three punchouts, two for electrical and one for data.
- Please specify duplex receptacles separately.

PRODUCT CODE	PRICE		SIZE/ INCHES			WEIGHT VOL	
	GR 1	GR 2	H	W	D	LBS	FT ³
CMFF4224P2	433	457	42	24	2.3	20	2.31
CMFF4230P2	551	578	42	30	2.3	25	2.85
CMFF4236P2	590	639	42	36	2.3	31	3.38
CMFF4242P2	654	701	42	42	2.3	36	3.92
CMFF4248P2	694	746	42	48	2.3	41	4.45
CMFF4254P2	745	792	42	54	2.3	46	4.99
CMFF4260P2	796	846	42	60	2.3	51	5.52
CMFF4266P2	975	1086	42	66	2.3	55	6.05
CMFF4272P2	1022	1130	42	72	2.3	60	6.60
CMFF4824P2	484	514	48	24	2.3	26	2.73
CMFF4830P2	580	610	48	30	2.3	33	3.37
CMFF4836P2	644	689	48	36	2.3	39	4.00
CMFF4842P2	717	778	48	42	2.3	46	4.63
CMFF4848P2	761	823	48	48	2.3	52	5.26
CMFF4854P2	817	879	48	54	2.3	59	5.89
CMFF4860P2	854	916	48	60	2.3	65	6.53
CMFF5424P2	484	514	54	24	2.3	26	2.73
CMFF5430P2	580	610	54	30	2.3	33	3.37
CMFF5436P2	644	689	54	36	2.3	39	4.00
CMFF5442P2	717	778	54	42	2.3	46	4.63
CMFF5448P2	761	823	54	48	2.3	52	5.26
CMFF5454P2	817	879	54	54	2.3	59	5.89
CMFF5460P2	854	916	54	60	2.3	65	6.53
CMFF6624P2	520	561	66	24	2.3	32	3.58
CMFF6630P2	612	653	66	30	2.3	40	4.40
CMFF6636P2	707	781	66	36	2.3	48	5.23
CMFF6642P2	780	854	66	42	2.3	56	6.06
CMFF6648P2	819	894	66	48	2.3	64	6.88
CMFF6654P2	880	955	66	54	2.3	72	7.71
CMFF6660P2	925	999	66	60	2.3	80	8.53

CMFL-N0 • Single Segmented Non Powered Laminate One Side Panel, No Punchouts

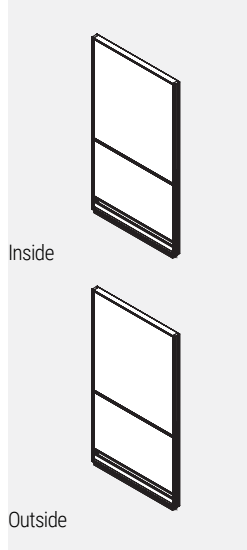

- Individual fabric or laminate covered modules incorporated into an aluminum frame.
- Modules have laminate on one side and fabric on the other.
- If different grades of fabric are used on one panel, the entire panel must be priced at highest grade.
- Panels are not tackable.
- Note: Trim is not required at a straight connection between two panels of the same height.
- 3 Panel connector brackets per side come standard with 30” to 54”h. panels.
- 4 Panel connector brackets per side come standard with 66”h. panels.
- Panels include 2 raceway covers with no punchouts, an integrated aluminum top cap and levelling glides.

PRODUCT CODE	PRICE		SIZE/ INCHES			WEIGHT VOL	
	GR 1	GR 2	H	W	D	LBS	FT ³
CMFL4224N0	464	477	42	24	2.3	20	2.31
CMFL4230N0	542	553	42	30	2.3	25	2.85
CMFL4236N0	623	641	42	36	2.3	31	3.38
CMFL4242N0	707	724	42	42	2.3	36	3.92
CMFL4248N0	766	788	42	48	2.3	41	4.45
CMFL4254N0	853	879	42	54	2.3	46	4.99
CMFL4260N0	935	962	42	60	2.3	51	5.52
CMFL4824N0	550	567	48	24	2.3	26	2.73
CMFL4830N0	647	665	48	30	2.3	33	3.37
CMFL4836N0	741	762	48	36	2.3	39	4.00
CMFL4842N0	839	864	48	42	2.3	46	4.63
CMFL4848N0	917	947	48	48	2.3	52	5.26
CMFL4854N0	1021	1052	48	54	2.3	59	5.89
CMFL4860N0	1122	1156	48	60	2.3	65	6.53
CMFL5424N0	550	567	54	24	2.3	26	2.73
CMFL5430N0	647	665	54	30	2.3	33	3.37
CMFL5436N0	741	762	54	36	2.3	39	4.00
CMFL5442N0	839	864	54	42	2.3	46	4.63
CMFL5448N0	917	947	54	48	2.3	52	5.26
CMFL5454N0	1021	1052	54	54	2.3	59	5.89
CMFL5460N0	1122	1156	54	60	2.3	65	6.53
CMFL6624N0	683	699	66	24	2.3	32	3.58
CMFL6630N0	796	820	66	30	2.3	40	4.4
CMFL6636N0	918	948	66	36	2.3	48	5.23
CMFL6642N0	1046	1078	66	42	2.3	56	6.06
CMFL6648N0	1139	1174	66	48	2.3	64	6.88
CMFL6654N0	1265	1303	66	54	2.3	72	7.71
CMFL6660N0	1395	1438	66	60	2.3	80	8.53

CMFL-N1 • Single Segmented Non Powered Laminate One Side Panel, Punchouts on One Side

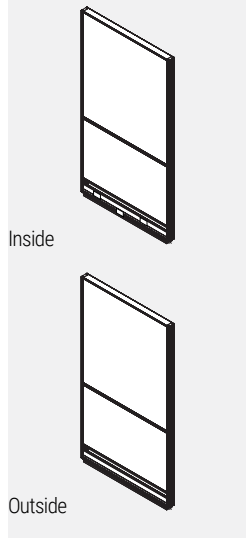

- Individual fabric or laminate covered modules incorporated into an aluminum frame.
- Modules have laminate on one side and fabric on the other.
- If different grades of fabric are used on one panel, the entire panel must be priced at highest grade.
- Panels are not tackable.
- Note: Trim is not required at a straight connection between two panels of the same height.
- 3 Panel connector brackets per side come standard with 30”h. to 54”h. panels.
- 4 Panel connector brackets per side come standard with 66”h. panels.
- Panels include 1 raceway cover with punchouts on one side, 1 raceway cover with no punchouts on the other, an integrated aluminum top cap and levelling glides.
- 24” wide panels have two punchouts, one for electrical and one for data.
- 30” wide panels and wider have three punchouts, two for electrical and one for data.

PRODUCT CODE	PRICE		SIZE/ INCHES			WEIGHT VOL	
	GR 1	GR 2	H	W	D	LBS	FT ³
CMFL4224N1	464	477	42	24	2.3	20	2.31
CMFL4230N1	542	553	42	30	2.3	25	2.85
CMFL4236N1	623	641	42	36	2.3	31	3.38
CMFL4242N1	707	724	42	42	2.3	36	3.92
CMFL4248N1	766	788	42	48	2.3	41	4.45
CMFL4254N1	853	879	42	54	2.3	46	4.99
CMFL4260N1	935	962	42	60	2.3	51	5.52
CMFL4824N1	550	567	48	24	2.3	26	2.73
CMFL4830N1	647	665	48	30	2.3	33	3.37
CMFL4836N1	741	762	48	36	2.3	39	4.00
CMFL4842N1	839	864	48	42	2.3	46	4.63
CMFL4848N1	917	947	48	48	2.3	52	5.26
CMFL4854N1	1021	1052	48	54	2.3	59	5.89
CMFL4860N1	1122	1156	48	60	2.3	65	6.53
CMFL5424N1	550	567	54	24	2.3	26	2.73
CMFL5430N1	647	665	54	30	2.3	33	3.37
CMFL5436N1	741	762	54	36	2.3	39	4.00
CMFL5442N1	839	864	54	42	2.3	46	4.63
CMFL5448N1	917	947	54	48	2.3	52	5.26
CMFL5454N1	1021	1052	54	54	2.3	59	5.89
CMFL5460N1	1122	1156	54	60	2.3	65	6.53
CMFL6624N1	683	699	66	24	2.3	32	3.58
CMFL6630N1	796	820	66	30	2.3	40	4.40
CMFL6636N1	918	948	66	36	2.3	48	5.23
CMFL6642N1	1046	1078	66	42	2.3	56	6.06
CMFL6648N1	1139	1174	66	48	2.3	64	6.88
CMFL6654N1	1265	1303	66	54	2.3	72	7.71
CMFL6660N1	1395	1438	66	60	2.3	80	8.53

CMFL-N2 • Single Segmented Non Powered Laminate One Side Panel, Punchouts on Both Sides

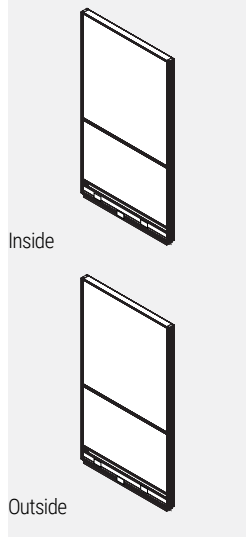

- Individual fabric or laminate covered modules incorporated into an aluminum frame.
- Modules have laminate on one side and fabric on the other.
- If different grades of fabric are used on one panel, the entire panel must be priced at highest grade.
- Panels are not tackable.
- Note: Trim is not required at a straight connection between two panels of the same height.
- 3 Panel connector brackets per side come standard with 30”h. to 54”h. panels.
- 4 Panel connector brackets per side come standard with 66”h. panels.
- Panels include 2 raceway covers with punchouts on both sides, an integrated aluminum top cap and levelling glides.
- 24” wide panels have two punchouts, one for electrical and one for data.
- 30” wide panels and wider have three punchouts, two for electrical and one for data.

PRODUCT CODE	PRICE		SIZE/ INCHES			WEIGHT VOL	
	GR 1	GR 2	H	W	D	LBS	FT ³
CMFL4224N2	464	477	42	24	2.3	20	2.31
CMFL4230N2	542	553	42	30	2.3	25	2.85
CMFL4236N2	623	641	42	36	2.3	31	3.38
CMFL4242N2	707	724	42	42	2.3	36	3.92
CMFL4248N2	766	788	42	48	2.3	41	4.45
CMFL4254N2	853	879	42	54	2.3	46	4.99
CMFL4260N2	935	962	42	60	2.3	51	5.52
CMFL4824N2	550	567	48	24	2.3	26	2.73
CMFL4830N2	647	665	48	30	2.3	33	3.37
CMFL4836N2	741	762	48	36	2.3	39	4.00
CMFL4842N2	839	864	48	42	2.3	46	4.63
CMFL4848N2	917	947	48	48	2.3	52	5.26
CMFL4854N2	1021	1052	48	54	2.3	59	5.89
CMFL4860N2	1122	1156	48	60	2.3	65	6.53
CMFL5424N2	550	567	54	24	2.3	26	2.73
CMFL5430N2	647	665	54	30	2.3	33	3.37
CMFL5436N2	741	762	54	36	2.3	39	4.00
CMFL5442N2	839	864	54	42	2.3	46	4.63
CMFL5448N2	917	947	54	48	2.3	52	5.26
CMFL5454N2	1021	1052	54	54	2.3	59	5.89
CMFL5460N2	1122	1156	54	60	2.3	65	6.53
CMFL6624N2	683	699	66	24	2.3	32	3.58
CMFL6630N2	796	820	66	30	2.3	40	4.40
CMFL6636N2	918	948	66	36	2.3	48	5.23
CMFL6642N2	1046	1078	66	42	2.3	56	6.06
CMFL6648N2	1139	1174	66	48	2.3	64	6.88
CMFL6654N2	1265	1303	66	54	2.3	72	7.71
CMFL6660N2	1395	1438	66	60	2.3	80	8.53

CMFL-P1 • Single Segmented Powered Laminate One Side Panel, Punchouts on One Side

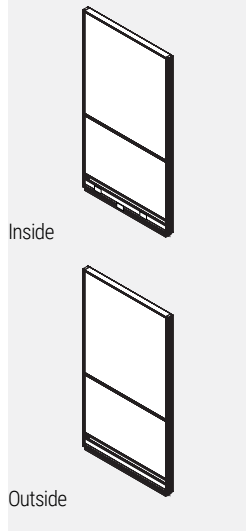

- Individual fabric or laminate covered modules incorporated into an aluminum frame.
- Modules have laminate on one side and fabric on the other.
- If different grades of fabric are used on one panel, the entire panel must be priced at highest grade.
- Panels are not tackable.
- Note: Trim is not required at a straight connection between two panels of the same height.
- 3 Panel connector brackets per side come standard with 30”h. to 54”h. panels.
- 4 Panel connector brackets per side come standard with 66”h. panels.
- Panels include 1 raceway cover with punchouts on one side, 1 raceway cover with no punchouts on the other, a power distribution housing, an integrated aluminum top cap and levelling glides.
- 24” wide panels have two punchouts, one for electrical and one for data.
- 30” wide panels and wider have three punchouts, two for electrical and one for data.
- Please specify duplex receptacles separately.

PRODUCT CODE	PRICE		SIZE/ H	INCHES			WEIGHT VOL	
	GR 1	GR 2		W	D	LBS	FT³	
CMFL4224P1	604	614	42	24	2.3	20	2.31	
CMFL4230P1	726	744	42	30	2.3	25	2.85	
CMFL4236P1	819	837	42	36	2.3	31	3.38	
CMFL4242P1	908	928	42	42	2.3	36	3.92	
CMFL4248P1	983	1001	42	48	2.3	41	4.45	
CMFL4254P1	1069	1094	42	54	2.3	46	4.99	
CMFL4260P1	1154	1180	42	60	2.3	51	5.52	
CMFL4824P1	689	705	48	24	2.3	26	2.73	
CMFL4830P1	833	852	48	30	2.3	33	3.37	
CMFL4836P1	936	959	48	36	2.3	39	4.00	
CMFL4842P1	1040	1065	48	42	2.3	46	4.63	
CMFL4848P1	1131	1158	48	48	2.3	52	5.26	
CMFL4854P1	1236	1267	48	54	2.3	59	5.89	
CMFL4860P1	1340	1375	48	60	2.3	65	6.53	
CMFL5424P1	689	705	54	24	2.3	26	2.73	
CMFL5430P1	833	852	54	30	2.3	33	3.37	
CMFL5436P1	936	959	54	36	2.3	39	4.00	
CMFL5442P1	1040	1065	54	42	2.3	46	4.63	
CMFL5448P1	1131	1158	54	48	2.3	52	5.26	
CMFL5454P1	1236	1267	54	54	2.3	59	5.89	
CMFL5460P1	1340	1375	54	60	2.3	65	6.53	
CMFL6624P1	823	840	66	24	2.3	32	3.58	
CMFL6630P1	984	1006	66	30	2.3	40	4.40	
CMFL6636P1	1114	1143	66	36	2.3	48	5.23	
CMFL6642P1	1246	1278	66	42	2.3	56	6.06	
CMFL6648P1	1352	1389	66	48	2.3	64	6.88	
CMFL6654P1	1482	1520	66	54	2.3	72	7.71	
CMFL6660P1	1613	1656	66	60	2.3	80	8.53	

CMFL-P2 • Single Segmented Powered Laminate One Side Panel, Punchouts on Both Sides

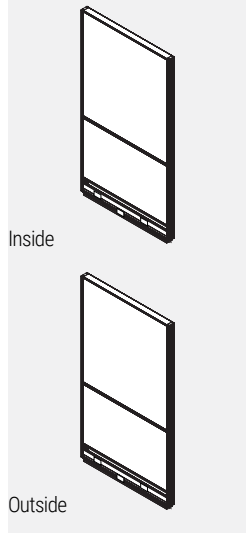

- Individual fabric or laminate covered modules incorporated into an aluminum frame.
- Modules have laminate on one side and fabric on the other.
- If different grades of fabric are used on one panel, the entire panel must be priced at highest grade.
- Panels are not tackable.
- Note: Trim is not required at a straight connection between two panels of the same height.
- 3 Panel connector brackets per side come standard with 30”h. to 54”h. panels.
- 4 Panel connector brackets per side come standard with 66”h. panels.
- Panels include 2 raceway covers with punchouts on both sides, a power distribution housing, an integrated aluminum top cap and levelling glides.
- 24” wide panels have two punchouts, one for electrical and one for data.
- 30” wide panels and wider have three punchouts, two for electrical and one for data.
- Please specify duplex receptacles separately.

PRODUCT CODE	PRICE		SIZE/ H	INCHES			WEIGHT VOL	
	GR 1	GR 2		W	D	LBS	FT³	
CMFL4224P2	604	614	42	24	2.3	20	2.31	
CMFL4230P2	726	744	42	30	2.3	25	2.85	
CMFL4236P2	819	837	42	36	2.3	31	3.38	
CMFL4242P2	908	928	42	42	2.3	36	3.92	
CMFL4248P2	983	1001	42	48	2.3	41	4.45	
CMFL4254P2	1069	1094	42	54	2.3	46	4.99	
CMFL4260P2	1154	1180	42	60	2.3	51	5.52	
CMFL4824P2	689	705	48	24	2.3	26	2.73	
CMFL4830P2	833	852	48	30	2.3	33	3.37	
CMFL4836P2	936	959	48	36	2.3	39	4.00	
CMFL4842P2	1040	1065	48	42	2.3	46	4.63	
CMFL4848P2	1131	1158	48	48	2.3	52	5.26	
CMFL4854P2	1236	1267	48	54	2.3	59	5.89	
CMFL4860P2	1340	1375	48	60	2.3	65	6.53	
CMFL5424P2	689	705	54	24	2.3	26	2.73	
CMFL5430P2	833	852	54	30	2.3	33	3.37	
CMFL5436P2	936	959	54	36	2.3	39	4.00	
CMFL5442P2	1040	1065	54	42	2.3	46	4.63	
CMFL5448P2	1131	1158	54	48	2.3	52	5.26	
CMFL5454P2	1236	1267	54	54	2.3	59	5.89	
CMFL5460P2	1340	1375	54	60	2.3	65	6.53	
CMFL6624P2	823	840	66	24	2.3	32	3.58	
CMFL6630P2	984	1006	66	30	2.3	40	4.40	
CMFL6636P2	1114	1143	66	36	2.3	48	5.23	
CMFL6642P2	1246	1278	66	42	2.3	56	6.06	
CMFL6648P2	1352	1389	66	48	2.3	64	6.88	
CMFL6654P2	1482	1520	66	54	2.3	72	7.71	
CMFL6660P2	1613	1656	66	60	2.3	80	8.53	

CMLL-N0 • Single Segmented Non Powered Laminate Two Sides Panel, No Punchouts

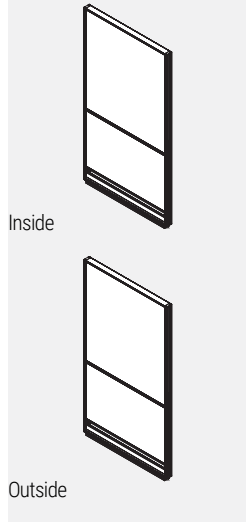

- Individual laminate covered modules incorporated into an aluminum frame.
- Opposite sides of each module may have a different laminate within the same grade at no upcharge.
- Note: Trim is not required at a straight connection between two panels of the same height.
- 3 Panel connector brackets per side come standard with 30" h. to 54" h. panels.
- 4 Panel connector brackets per side come standard with 66" h. panels.
- Panels include 2 raceway covers with no punchouts, an integrated aluminum top cap and levelling glides.

PRODUCT CODE	PRICE	SIZE/ INCHES			WEIGHT VOL	
		H	W	D	LBS	FT ³
CMLL4224N0	527	42	24	2.3	20	2.31
CMLL4230N0	622	42	30	2.3	25	2.85
CMLL4236N0	722	42	36	2.3	31	3.38
CMLL4242N0	825	42	42	2.3	36	3.92
CMLL4248N0	922	42	48	2.3	41	4.45
CMLL4254N0	1017	42	54	2.3	46	4.99
CMLL4260N0	1107	42	60	2.3	51	5.52
CMLL4824N0	625	48	24	2.3	26	2.73
CMLL4830N0	741	48	30	2.3	33	3.37
CMLL4836N0	860	48	36	2.3	39	4.00
CMLL4842N0	983	48	42	2.3	46	4.63
CMLL4848N0	1107	48	48	2.3	52	5.26
CMLL4854N0	1216	48	54	2.3	59	5.89
CMLL4860N0	1326	48	60	2.3	65	6.53
CMLL5424N0	625	54	24	2.3	26	2.73
CMLL5430N0	741	54	30	2.3	33	3.37
CMLL5436N0	860	54	36	2.3	39	4.00
CMLL5442N0	983	54	42	2.3	46	4.63
CMLL5448N0	1107	54	48	2.3	52	5.26
CMLL5454N0	1216	54	54	2.3	59	5.89
CMLL5460N0	1326	54	60	2.3	65	6.53
CMLL6624N0	788	66	24	2.3	32	3.58
CMLL6630N0	935	66	30	2.3	40	4.40
CMLL6636N0	1087	66	36	2.3	48	5.23
CMLL6642N0	1244	66	42	2.3	56	6.06
CMLL6648N0	1395	66	48	2.3	64	6.88
CMLL6654N0	1541	66	54	2.3	72	7.71
CMLL6660N0	1684	66	60	2.3	80	8.53

CMLL-N1 • Single Segmented Non Powered Laminate Two Sides Panel, Punchouts on One Side

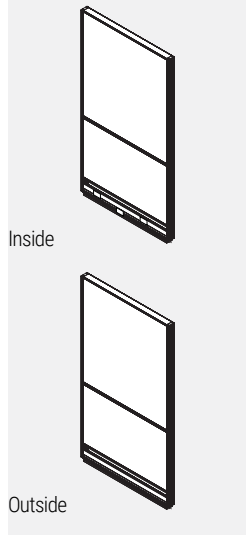

- Individual laminate covered modules incorporated into an aluminum frame.
- Opposite sides of each module may have a different laminate within the same grade at no upcharge.
- Note: Trim is not required at a straight connection between two panels of the same height.
- 3 Panel connector brackets per side come standard with 30" h. to 54" h. panels.
- 4 Panel connector brackets per side come standard with 66" h. panels.
- Panels include 1 raceway cover with punchouts on one side, 1 raceway cover with no punchouts on the other, an integrated aluminum top cap and levelling glides.
- 24" wide panels have two punchouts, one for electrical and one for data.
- 30" wide panels and wider have three punchouts, two for electrical and one for data.

PRODUCT CODE	PRICE	SIZE/ INCHES			WEIGHT VOL	
		H	W	D	LBS	FT ³
CMLL4224N1	527	42	24	2.3	20	2.31
CMLL4230N1	622	42	30	2.3	25	2.85
CMLL4236N1	722	42	36	2.3	31	3.38
CMLL4242N1	825	42	42	2.3	36	3.92
CMLL4248N1	922	42	48	2.3	41	4.45
CMLL4254N1	1017	42	54	2.3	46	4.99
CMLL4260N1	1107	42	60	2.3	51	5.52
CMLL4824N1	625	48	24	2.3	26	2.73
CMLL4830N1	741	48	30	2.3	33	3.37
CMLL4836N1	860	48	36	2.3	39	4.00
CMLL4842N1	983	48	42	2.3	46	4.63
CMLL4848N1	1107	48	48	2.3	52	5.26
CMLL4854N1	1216	48	54	2.3	59	5.89
CMLL4860N1	1326	48	60	2.3	65	6.53
CMLL5424N1	625	54	24	2.3	26	2.73
CMLL5430N1	741	54	30	2.3	33	3.37
CMLL5436N1	860	54	36	2.3	39	4.00
CMLL5442N1	983	54	42	2.3	46	4.63
CMLL5448N1	1107	54	48	2.3	52	5.26
CMLL5454N1	1216	54	54	2.3	59	5.89
CMLL5460N1	1326	54	60	2.3	65	6.53
CMLL6624N1	788	66	24	2.3	32	3.58
CMLL6630N1	935	66	30	2.3	40	4.40
CMLL6636N1	1087	66	36	2.3	48	5.23
CMLL6642N1	1244	66	42	2.3	56	6.06
CMLL6648N1	1395	66	48	2.3	64	6.88
CMLL6654N1	1541	66	54	2.3	72	7.71
CMLL6660N1	1684	66	60	2.3	80	8.53

CMLL-N2 • Single Segmented Non Powered Laminate Two Sides Panel, Punchouts on Both Sides

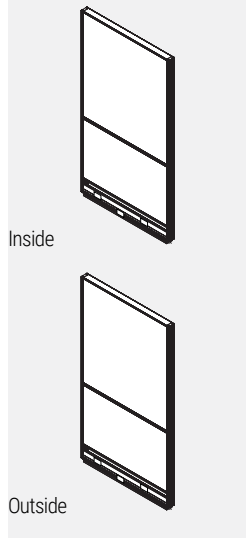

- Individual laminate covered modules incorporated into an aluminum frame.
- Opposite sides of each module may have a different laminate within the same grade at no upcharge.
- Note: Trim is not required at a straight connection between two panels of the same height.
- 3 Panel connector brackets per side come standard with 30”h. to 54”h. panels.
- 4 Panel connector brackets per side come standard with 66”h. panels.
- Panels include 2 raceway covers with punchouts on both sides, an integrated aluminum top cap and levelling glides.
- 24” wide panels have two punchouts, one for electrical and one for data.
- 30” wide panels and wider have three punchouts, two for electrical and one for data.

PRODUCT CODE	PRICE	SIZE/ INCHES			WEIGHT VOL	
		H	W	D	LBS	FT ³
CMLL4224N2	527	42	24	2.3	20	2.31
CMLL4230N2	622	42	30	2.3	25	2.85
CMLL4236N2	722	42	36	2.3	31	3.38
CMLL4242N2	825	42	42	2.3	36	3.92
CMLL4248N2	922	42	48	2.3	41	4.45
CMLL4254N2	1017	42	54	2.3	46	4.99
CMLL4260N2	1107	42	60	2.3	51	5.52
CMLL4824N2	625	48	24	2.3	26	2.73
CMLL4830N2	741	48	30	2.3	33	3.37
CMLL4836N2	860	48	36	2.3	39	4.00
CMLL4842N2	983	48	42	2.3	46	4.63
CMLL4848N2	1107	48	48	2.3	52	5.26
CMLL4854N2	1216	48	54	2.3	59	5.89
CMLL4860N2	1326	48	60	2.3	65	6.53
CMLL5424N2	625	54	24	2.3	26	2.73
CMLL5430N2	741	54	30	2.3	33	3.37
CMLL5436N2	860	54	36	2.3	39	4
CMLL5442N2	983	54	42	2.3	46	4.63
CMLL5448N2	1107	54	48	2.3	52	5.26
CMLL5454N2	1216	54	54	2.3	59	5.89
CMLL5460N2	1326	54	60	2.3	65	6.53
CMLL6624N2	788	66	24	2.3	32	3.58
CMLL6630N2	935	66	30	2.3	40	4.4
CMLL6636N2	1087	66	36	2.3	48	5.23
CMLL6642N2	1244	66	42	2.3	56	6.06
CMLL6648N2	1395	66	48	2.3	64	6.88
CMLL6654N2	1541	66	54	2.3	72	7.71
CMLL6660N2	1684	66	60	2.3	80	8.53

CMLL-P1 • Single Segmented Powered Laminate Two Sides Panel, Punchouts on One Side

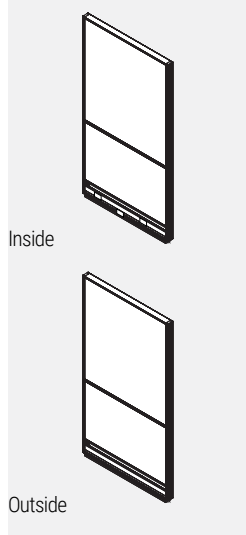

- Individual laminate covered modules incorporated into an aluminum frame.
- Opposite sides of each module may have a different laminate within the same grade at no upcharge.
- Note: Trim is not required at a straight connection between two panels of the same height.
- 3 Panel connector brackets per side come standard with 30”h. to 54”h. panels.
- 4 Panel connector brackets per side come standard with 66”h. panels.
- Panels include 1 raceway cover with punchouts on one side, 1 raceway cover with no punchouts on the other, a power distribution housing, an integrated aluminum top cap and levelling glides.
- 24” wide panels have two punchouts, one for electrical and one for data.
- 30” wide panels and wider have three punchouts, two for electrical and one for data.
- Please specify duplex receptacles separately.

PRODUCT CODE	PRICE	SIZE/ INCHES			WEIGHT VOL	
		H	W	D	LBS	FT ³
CMLL4224P1	666	42	24	2.3	20	2.31
CMLL4230P1	809	42	30	2.3	25	2.85
CMLL4236P1	918	42	36	2.3	31	3.38
CMLL4242P1	1027	42	42	2.3	36	3.92
CMLL4248P1	1137	42	48	2.3	41	4.45
CMLL4254P1	1234	42	54	2.3	46	4.99
CMLL4260P1	1326	42	60	2.3	51	5.52
CMLL4824P1	762	48	24	2.3	26	2.73
CMLL4830P1	928	48	30	2.3	33	3.37
CMLL4836P1	1056	48	36	2.3	39	4.00
CMLL4842P1	1182	48	42	2.3	46	4.63
CMLL4848P1	1323	48	48	2.3	52	5.26
CMLL4854P1	1435	48	54	2.3	59	5.89
CMLL4860P1	1543	48	60	2.3	65	6.53
CMLL5424P1	762	54	24	2.3	26	2.73
CMLL5430P1	928	54	30	2.3	33	3.37
CMLL5436P1	1056	54	36	2.3	39	4
CMLL5442P1	1182	54	42	2.3	46	4.63
CMLL5448P1	1323	54	48	2.3	52	5.26
CMLL5454P1	1435	54	54	2.3	59	5.89
CMLL5460P1	1543	54	60	2.3	65	6.53
CMLL6624P1	928	66	24	2.3	32	3.58
CMLL6630P1	1122	66	30	2.3	40	4.4
CMLL6636P1	1283	66	36	2.3	48	5.23
CMLL6642P1	1447	66	42	2.3	56	6.06
CMLL6648P1	1608	66	48	2.3	64	6.88
CMLL6654P1	1757	66	54	2.3	72	7.71
CMLL6660P1	1903	66	60	2.3	80	8.53

CMLL-P2 • Single Segmented Powered Laminate Two Sides Panel, Punchouts on Both Sides

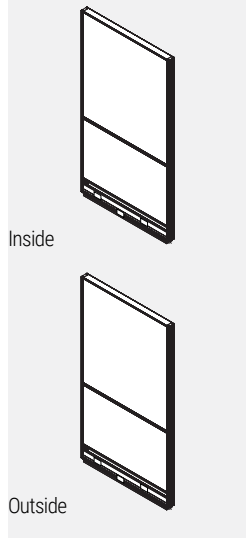

- Individual laminate covered modules incorporated into an aluminum frame.
- Opposite sides of each module may have a different laminate within the same grade at no upcharge.
- Note: Trim is not required at a straight connection between two panels of the same height.
- 3 Panel connector brackets per side come standard with 30”h. to 54”h. panels.
- 4 Panel connector brackets per side come standard with 66”h. panels.
- Panels include 2 raceway covers with punchouts on both sides, a power distribution housing, an integrated aluminum top cap and levelling glides.
- 24” wide panels have two punchouts, one for electrical and one for data.
- 30” wide panels and wider have three punchouts, two for electrical and one for data.
- Please specify duplex receptacles separately.

PRODUCT CODE	PRICE	SIZE/ INCHES			WEIGHT VOL	
		H	W	D	LBS	FT ³
CMLL4224P2	666	42	24	2.3	20	2.31
CMLL4230P2	809	42	30	2.3	25	2.85
CMLL4236P2	918	42	36	2.3	31	3.38
CMLL4242P2	1027	42	42	2.3	36	3.92
CMLL4248P2	1137	42	48	2.3	41	4.45
CMLL4254P2	1234	42	54	2.3	46	4.99
CMLL4260P2	1326	42	60	2.3	51	5.52
CMLL4824P2	762	48	24	2.3	26	2.73
CMLL4830P2	928	48	30	2.3	33	3.37
CMLL4836P2	1056	48	36	2.3	39	4.00
CMLL4842P2	1182	48	42	2.3	46	4.63
CMLL4848P2	1323	48	48	2.3	52	5.26
CMLL4854P2	1435	48	54	2.3	59	5.89
CMLL4860P2	1543	48	60	2.3	65	6.53
CMLL5424P2	762	54	24	2.3	26	2.73
CMLL5430P2	928	54	30	2.3	33	3.37
CMLL5436P2	1056	54	36	2.3	39	4
CMLL5442P2	1182	54	42	2.3	46	4.63
CMLL5448P2	1323	54	48	2.3	52	5.26
CMLL5454P2	1435	54	54	2.3	59	5.89
CMLL5460P2	1543	54	60	2.3	65	6.53
CMLL6624P2	928	66	24	2.3	32	3.58
CMLL6630P2	1122	66	30	2.3	40	4.4
CMLL6636P2	1283	66	36	2.3	48	5.23
CMLL6642P2	1447	66	42	2.3	56	6.06
CMLL6648P2	1608	66	48	2.3	64	6.88
CMLL6654P2	1757	66	54	2.3	72	7.71
CMLL6660P2	1903	66	60	2.3	80	8.53

CMFW-N0 • Single Segmented Non Powered Write Board One Side Panel, No Punchouts

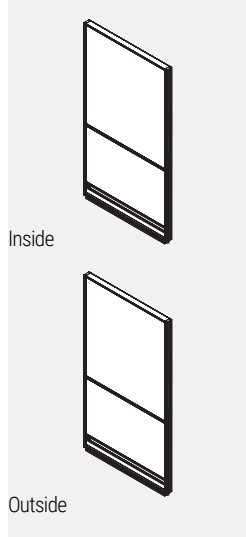

- Individual fabric or write board covered modules incorporated into an aluminum frame.
- Modules have write board on one side and fabric on the other at the top and fabric on two sides at the bottom.
- If different grades of fabric are used on one panel, the entire panel must be priced at highest grade.
- Panels are not tackable.
- Note: Trim is not required at a straight connection between two panels of the same height.
- 3 Panel connector brackets per side come standard with 30”h. to 54”h. panels.
- 4 Panel connector brackets per side come standard with 66”h. panels.
- Panels include 2 raceway covers with no punchouts, an integrated aluminum top cap and levelling glides.

PRODUCT CODE	PRICE		SIZE/ INCHES			WEIGHT VOL	
	GR 1	GR 2	H	W	D	LBS	FT ³
CMFW4824N0	494	517	48	24	2.3	26	2.73
CMFW4830N0	595	623	48	30	2.3	33	3.37
CMFW4836N0	658	691	48	36	2.3	39	4.00
CMFW4842N0	744	781	48	42	2.3	46	4.63
CMFW4848N0	837	877	48	48	2.3	52	5.26
CMFW4854N0	931	964	48	54	2.3	59	5.89
CMFW4860N0	1026	1079	48	60	2.3	65	6.53
CMFW5424N0	494	517	54	24	2.3	26	2.73
CMFW5430N0	593	622	54	30	2.3	33	3.37
CMFW5436N0	658	691	54	36	2.3	39	4
CMFW5442N0	745	781	54	42	2.3	46	4.63
CMFW5448N0	837	879	54	48	2.3	52	5.26
CMFW5454N0	931	963	54	54	2.3	59	5.89
CMFW5460N0	1026	1079	54	60	2.3	65	6.53
CMFW6624N0	623	654	66	24	2.3	32	3.58
CMFW6630N0	741	778	66	30	2.3	40	4.4
CMFW6636N0	824	867	66	36	2.3	48	5.23
CMFW6642N0	933	984	66	42	2.3	56	6.06
CMFW6648N0	1041	1096	66	48	2.3	64	6.88
CMFW6654N0	1160	1223	66	54	2.3	72	7.71
CMFW6660N0	1279	1348	66	60	2.3	80	8.53

CMFW-N1 • Single Segmented Non Powered Write Board One Side Panel, Punchouts on One Side

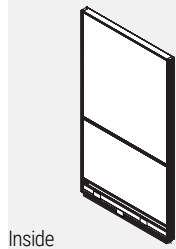

Inside

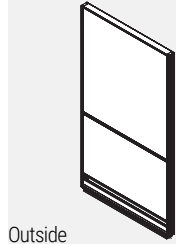

Outside

- Individual fabric or write board covered modules incorporated into an aluminum frame.
- Modules have write board on one side and fabric on the other at the top and fabric on two sides at the bottom.
- If different grades of fabric are used on one panel, the entire panel must be priced at highest grade.
- Panels are not tackable.
- Note: Trim is not required at a straight connection between two panels of the same height.
- 3 Panel connector brackets per side come standard with 30”h. to 54”h. panels.
- 4 Panel connector brackets per side come standard with 66”h. panels.
- Panels include 1 raceway cover with punchouts on one side, 1 raceway cover with no punchouts on the other, an integrated aluminum top cap and levelling glides.
- 24” wide panels have two punchouts, one for electrical and one for data.
- 30” wide panels and wider have three punchouts, two for electrical and one for data.

PRODUCT CODE	PRICE		SIZE/ INCHES			WEIGHT VOL	
	GR 1	GR 2	H	W	D	LBS	FT ³
CMFW4824N1	494	517	48	24	2.3	26	2.73
CMFW4830N1	595	623	48	30	2.3	33	3.37
CMFW4836N1	658	691	48	36	2.3	39	4.00
CMFW4842N1	744	781	48	42	2.3	46	4.63
CMFW4848N1	837	877	48	48	2.3	52	5.26
CMFW4854N1	931	964	48	54	2.3	59	5.89
CMFW4860N1	1026	1079	48	60	2.3	65	6.53
CMFW5424N1	494	517	54	24	2.3	26	2.73
CMFW5430N1	593	622	54	30	2.3	33	3.37
CMFW5436N1	658	691	54	36	2.3	39	4
CMFW5442N1	745	781	54	42	2.3	46	4.63
CMFW5448N1	837	879	54	48	2.3	52	5.26
CMFW5454N1	931	963	54	54	2.3	59	5.89
CMFW5460N1	1026	1079	54	60	2.3	65	6.53
CMFW6624N1	623	654	66	24	2.3	32	3.58
CMFW6630N1	741	778	66	30	2.3	40	4.4
CMFW6636N1	824	867	66	36	2.3	48	5.23
CMFW6642N1	933	984	66	42	2.3	56	6.06
CMFW6648N1	1041	1096	66	48	2.3	64	6.88
CMFW6654N1	1160	1223	66	54	2.3	72	7.71
CMFW6660N1	1279	1348	66	60	2.3	80	8.53

CMFW-N2 • Single Segmented Non Powered Write Board One Side Panel, Punchouts on Both Sides

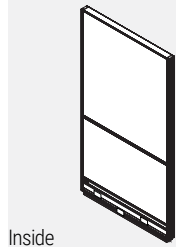

Inside

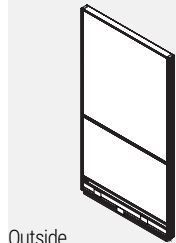

Outside

- Individual fabric or write board covered modules incorporated into an aluminum frame.
- Modules have write board on one side and fabric on the other at the top and fabric on two sides at the bottom.
- If different grades of fabric are used on one panel, the entire panel must be priced at highest grade.
- Panels are not tackable.
- Note: Trim is not required at a straight connection between two panels of the same height.
- 3 Panel connector brackets per side come standard with 30”h. to 54”h. panels.
- 4 Panel connector brackets per side come standard with 66”h. panels.
- Panels include 2 raceway covers with punchouts on both sides, an integrated aluminum top cap and levelling glides.
- 24” wide panels have two punchouts, one for electrical and one for data.
- 30” wide panels and wider have three punchouts, two for electrical and one for data.

PRODUCT CODE	PRICE		SIZE/ INCHES			WEIGHT VOL	
	GR 1	GR 2	H	W	D	LBS	FT ³
CMFW4824N2	494	517	48	24	2.3	26	2.73
CMFW4830N2	595	623	48	30	2.3	33	3.37
CMFW4836N2	658	691	48	36	2.3	39	4.00
CMFW4842N2	744	781	48	42	2.3	46	4.63
CMFW4848N2	837	877	48	48	2.3	52	5.26
CMFW4854N2	931	964	48	54	2.3	59	5.89
CMFW4860N2	1026	1079	48	60	2.3	65	6.53
CMFW5424N2	494	517	54	24	2.3	26	2.73
CMFW5430N2	593	622	54	30	2.3	33	3.37
CMFW5436N2	658	691	54	36	2.3	39	4
CMFW5442N2	745	781	54	42	2.3	46	4.63
CMFW5448N2	837	879	54	48	2.3	52	5.26
CMFW5454N2	931	963	54	54	2.3	59	5.89
CMFW5460N2	1026	1079	54	60	2.3	65	6.53
CMFW6624N2	623	654	66	24	2.3	32	3.58
CMFW6630N2	741	778	66	30	2.3	40	4.4
CMFW6636N2	824	867	66	36	2.3	48	5.23
CMFW6642N2	933	984	66	42	2.3	56	6.06
CMFW6648N2	1041	1096	66	48	2.3	64	6.88
CMFW6654N2	1160	1223	66	54	2.3	72	7.71
CMFW6660N2	1279	1348	66	60	2.3	80	8.53

CMFW-P1 • Single Segmented Powered Write Board One Side Panel, Punchouts on One Side

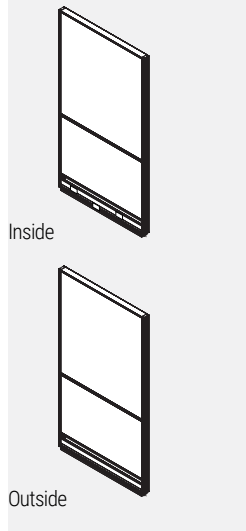

- Individual fabric or write board covered modules incorporated into an aluminum frame.
- Modules have write board on one side and fabric on the other at the top and fabric on two sides at the bottom.
- If different grades of fabric are used on one panel, the entire panel must be priced at highest grade.
- Panels are not tackable.
- Note: Trim is not required at a straight connection between two panels of the same height.
- 3 Panel connector brackets per side come standard with 30”h. to 54”h. panels.
- 4 Panel connector brackets per side come standard with 66”h. panels.
- Panels include 1 raceway cover with punchouts on one side, 1 raceway cover with no punchouts on the other, a power distribution housing, an integrated aluminum top cap and levelling glides.
- 24” wide panels have two punchouts, one for electrical and one for data.
- 30” wide panels and wider have three punchouts, two for electrical and one for data.
- Please specify duplex receptacles separately.

PRODUCT CODE	PRICE		SIZE/ INCHES			WEIGHT VOL	
	GR 1	GR 2	H	W	D	LBS	FT ³
CMFW4824P1	633	656	48	24	2.3	26	2.73
CMFW4830P1	781	808	48	30	2.3	33	3.37
CMFW4836P1	854	886	48	36	2.3	39	4.00
CMFW4842P1	947	984	48	42	2.3	46	4.63
CMFW4848P1	1052	1091	48	48	2.3	52	5.26
CMFW4854P1	1148	1179	48	54	2.3	59	5.89
CMFW4860P1	1243	1298	48	60	2.3	65	6.53
CMFW5424P1	633	656	54	24	2.3	26	2.73
CMFW5430P1	781	809	54	30	2.3	33	3.37
CMFW5436P1	854	886	54	36	2.3	39	4
CMFW5442P1	947	984	54	42	2.3	46	4.63
CMFW5448P1	1052	1091	54	48	2.3	52	5.26
CMFW5454P1	1148	1180	54	54	2.3	59	5.89
CMFW5460P1	1243	1298	54	60	2.3	65	6.53
CMFW6624P1	761	791	66	24	2.3	32	3.58
CMFW6630P1	928	963	66	30	2.3	40	4.4
CMFW6636P1	1021	1063	66	36	2.3	48	5.23
CMFW6642P1	1135	1186	66	42	2.3	56	6.06
CMFW6648P1	1258	1312	66	48	2.3	64	6.88
CMFW6654P1	1378	1438	66	54	2.3	72	7.71
CMFW6660P1	1499	1567	66	60	2.3	80	8.53

CMFW-P2 • Single Segmented Powered Write Board One Side Panel, Punchouts on Both Sides

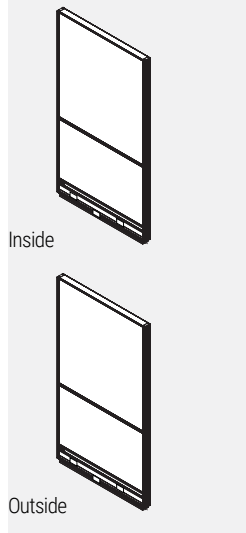

- Individual fabric or write board covered modules incorporated into an aluminum frame.
- Modules have write board on one side and fabric on the other at the top and fabric on two sides at the bottom.
- If different grades of fabric are used on one panel, the entire panel must be priced at highest grade.
- Panels are not tackable.
- Note: Trim is not required at a straight connection between two panels of the same height.
- 3 Panel connector brackets per side come standard with 30”h. to 54”h. panels.
- 4 Panel connector brackets per side come standard with 66”h. panels.
- Panels include 2 raceway covers with punchouts on both sides, a power distribution housing, an integrated aluminum top cap and levelling glides.
- 24” wide panels have two punchouts, one for electrical and one for data.
- 30” wide panels and wider have three punchouts, two for electrical and one for data.
- Please specify duplex receptacles separately.

PRODUCT CODE	PRICE		SIZE/ INCHES			WEIGHT VOL	
	GR 1	GR 2	H	W	D	LBS	FT ³
CMFW4824P2	633	656	48	24	2.3	26	2.73
CMFW4830P2	781	808	48	30	2.3	33	3.37
CMFW4836P2	854	886	48	36	2.3	39	4.00
CMFW4842P2	947	984	48	42	2.3	46	4.63
CMFW4848P2	1052	1091	48	48	2.3	52	5.26
CMFW4854P2	1148	1179	48	54	2.3	59	5.89
CMFW4860P2	1243	1298	48	60	2.3	65	6.53
CMFW5424P2	633	656	54	24	2.3	26	2.73
CMFW5430P2	781	809	54	30	2.3	33	3.37
CMFW5436P2	854	886	54	36	2.3	39	4
CMFW5442P2	947	984	54	42	2.3	46	4.63
CMFW5448P2	1052	1091	54	48	2.3	52	5.26
CMFW5454P2	1148	1180	54	54	2.3	59	5.89
CMFW5460P2	1243	1298	54	60	2.3	65	6.53
CMFW6624P2	761	791	66	24	2.3	32	3.58
CMFW6630P2	928	963	66	30	2.3	40	4.4
CMFW6636P2	1021	1063	66	36	2.3	48	5.23
CMFW6642P2	1135	1186	66	42	2.3	56	6.06
CMFW6648P2	1258	1312	66	48	2.3	64	6.88
CMFW6654P2	1378	1438	66	54	2.3	72	7.71
CMFW6660P2	1499	1567	66	60	2.3	80	8.53

CMWW-N0 • Single Segmented Non Powered Write Board Two Sides Panel, No Punchouts

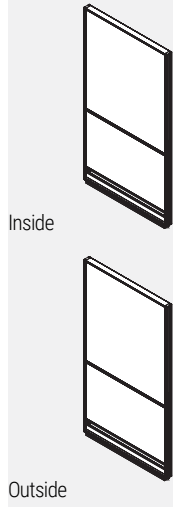

- Individual fabric or write board covered modules incorporated into an aluminum frame.
- Modules have either write board on two sides at the top and fabric on two sides at the bottom.
- If different grades of fabric are used on one panel, the entire panel must be priced at highest grade.
- Panels are not tackable.
- Note: Trim is not required at a straight connection between two panels of the same height.
- 3 Panel connector brackets per side come standard with 30”h. to 54”h. panels.
- 4 Panel connector brackets per side come standard with 66”h. panels.
- Panels include 2 raceway covers with no punchouts, an integrated aluminum top cap and levelling glides.

PRODUCT CODE	PRICE		SIZE/ INCHES			WEIGHT		VOL FT³
	GR 1	GR 2	H	W	D	LBS		
CMWW4824N0	539	551	48	24	2.3	26	2.73	
CMWW4830N0	671	688	48	30	2.3	33	3.37	
CMWW4836N0	725	751	48	36	2.3	39	4.00	
CMWW4842N0	825	849	48	42	2.3	46	4.63	
CMWW4848N0	965	995	48	48	2.3	52	5.26	
CMWW4854N0	1074	1108	48	54	2.3	59	5.89	
CMWW4860N0	1186	1216	48	60	2.3	65	6.53	
CMWW5424N0	539	551	54	24	2.3	26	2.73	
CMWW5430N0	671	688	54	30	2.3	33	3.37	
CMWW5436N0	725	751	54	36	2.3	39	4	
CMWW5442N0	825	850	54	42	2.3	46	4.63	
CMWW5448N0	964	995	54	48	2.3	52	5.26	
CMWW5454N0	1074	1107	54	54	2.3	59	5.89	
CMWW5460N0	1186	1218	54	60	2.3	65	6.53	
CMWW6624N0	661	687	66	24	2.3	32	3.58	
CMWW6630N0	817	845	66	30	2.3	40	4.4	
CMWW6636N0	892	922	66	36	2.3	48	5.23	
CMWW6642N0	1016	1053	66	42	2.3	56	6.06	
CMWW6648N0	1166	1205	66	48	2.3	64	6.88	
CMWW6654N0	1299	1345	66	54	2.3	72	7.71	
CMWW6660N0	1436	1485	66	60	2.3	80	8.53	

CMWW-N1 • Single Segmented Non Powered Write Board Two Sides Panel, Punchouts on One Side

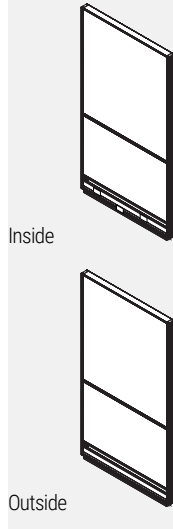

- Individual fabric or write board covered modules incorporated into an aluminum frame.
- Modules have either write board on two sides at the top and fabric on two sides at the bottom.
- If different grades of fabric are used on one panel, the entire panel must be priced at highest grade.
- Panels are not tackable.
- Note: Trim is not required at a straight connection between two panels of the same height.
- 3 Panel connector brackets per side come standard with 30”h. to 54”h. panels.
- 4 Panel connector brackets per side come standard with 66”h. panels.
- Panels include 1 raceway cover with punchouts on two sides, 1 raceway cover with no punchouts on the other, an integrated aluminum top cap and levelling glides.
- 24” wide panels have two punchouts, one for electrical and one for data.
- 30” wide panels and wider have three punchouts, two for electrical and one for data.

PRODUCT CODE	PRICE		SIZE/ INCHES			WEIGHT		VOL FT³
	GR 1	GR 2	H	W	D	LBS		
CMWW4824N1	539	551	48	24	2.3	26	2.73	
CMWW4830N1	671	688	48	30	2.3	33	3.37	
CMWW4836N1	725	751	48	36	2.3	39	4.00	
CMWW4842N1	825	849	48	42	2.3	46	4.63	
CMWW4848N1	965	995	48	48	2.3	52	5.26	
CMWW4854N1	1074	1108	48	54	2.3	59	5.89	
CMWW4860N1	1186	1216	48	60	2.3	65	6.53	
CMWW5424N1	539	551	54	24	2.3	26	2.73	
CMWW5430N1	671	688	54	30	2.3	33	3.37	
CMWW5436N1	725	751	54	36	2.3	39	4	
CMWW5442N1	825	850	54	42	2.3	46	4.63	
CMWW5448N1	964	995	54	48	2.3	52	5.26	
CMWW5454N1	1074	1107	54	54	2.3	59	5.89	
CMWW5460N1	1186	1218	54	60	2.3	65	6.53	
CMWW6624N1	661	687	66	24	2.3	32	3.58	
CMWW6630N1	817	845	66	30	2.3	40	4.4	
CMWW6636N1	892	922	66	36	2.3	48	5.23	
CMWW6642N1	1016	1053	66	42	2.3	56	6.06	
CMWW6648N1	1166	1205	66	48	2.3	64	6.88	
CMWW6654N1	1299	1345	66	54	2.3	72	7.71	
CMWW6660N1	1436	1485	66	60	2.3	80	8.53	

CMWW-N2 • Single Segmented Non Powered Write Board Two Sides Panel, Punchouts on Both Sides

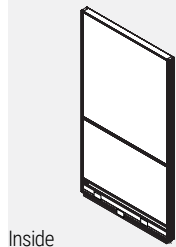

Inside

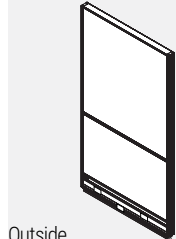

Outside

- Individual fabric or write board covered modules incorporated into an aluminum frame.
- Modules have either write board on two sides at the top and fabric on two sides at the bottom.
- If different grades of fabric are used on one panel, the entire panel must be priced at highest grade.
- Panels are not tackable.
- Note: Trim is not required at a straight connection between two panels of the same height.
- 3 Panel connector brackets per side come standard with 30”h. to 54”h. panels.
- 4 Panel connector brackets per side come standard with 66”h. panels.
- Panels include 2 raceway covers with punchouts on both sides, an integrated aluminum top cap and levelling glides.
- 24” wide panels have two punchouts, one for electrical and one for data.
- 30” wide panels and wider have three punchouts, two for electrical and one for data.

PRODUCT CODE	PRICE		SIZE/ INCHES			WEIGHT VOL	
	GR 1	GR 2	H	W	D	LBS	FT ³
CMWW4824N2	539	551	48	24	2.3	26	2.73
CMWW4830N2	671	688	48	30	2.3	33	3.37
CMWW4836N2	725	751	48	36	2.3	39	4.00
CMWW4842N2	825	849	48	42	2.3	46	4.63
CMWW4848N2	965	995	48	48	2.3	52	5.26
CMWW4854N2	1074	1108	48	54	2.3	59	5.89
CMWW4860N2	1186	1216	48	60	2.3	65	6.53
CMWW5424N2	539	551	54	24	2.3	26	2.73
CMWW5430N2	671	688	54	30	2.3	33	3.37
CMWW5436N2	725	751	54	36	2.3	39	4
CMWW5442N2	825	850	54	42	2.3	46	4.63
CMWW5448N2	964	995	54	48	2.3	52	5.26
CMWW5454N2	1074	1107	54	54	2.3	59	5.89
CMWW5460N2	1186	1218	54	60	2.3	65	6.53
CMWW6624N2	661	687	66	24	2.3	32	3.58
CMWW6630N2	817	845	66	30	2.3	40	4.4
CMWW6636N2	892	922	66	36	2.3	48	5.23
CMWW6642N2	1016	1053	66	42	2.3	56	6.06
CMWW6648N2	1166	1205	66	48	2.3	64	6.88
CMWW6654N2	1299	1345	66	54	2.3	72	7.71
CMWW6660N2	1436	1485	66	60	2.3	80	8.53

CMWW-P1 • Single Segmented Powered Write Board Two Sides Panel, Punchouts on One Side

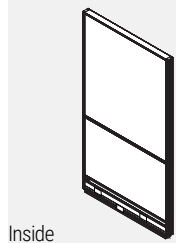

Inside

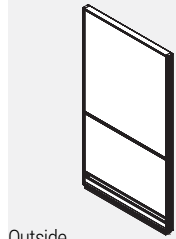

Outside

- Individual fabric or write board covered modules incorporated into an aluminum frame.
- Modules have either write board on two sides at the top and fabric on two sides at the bottom.
- If different grades of fabric are used on one panel, the entire panel must be priced at highest grade.
- Panels are not tackable.
- Note: Trim is not required at a straight connection between two panels of the same height.
- 3 Panel connector brackets per side come standard with 30”h. to 54”h. panels.
- 4 Panel connector brackets per side come standard with 66”h. panels.
- Panels include 1 raceway cover with punchouts on two sides, 1 raceway cover with no punchouts on the other, a power distribution housing, an integrated aluminum top cap and levelling glides.
- 24” wide panels have two punchouts, one for electrical and one for data.
- 30” wide panels and wider have three punchouts, two for electrical and one for data.
- Please specify duplex receptacles separately.

PRODUCT CODE	PRICE		SIZE/ INCHES			WEIGHT VOL	
	GR 1	GR 2	H	W	D	LBS	FT ³
CMWW4824P1	676	691	48	24	2.3	26	2.73
CMWW4830P1	857	873	48	30	2.3	33	3.37
CMWW4836P1	922	948	48	36	2.3	39	4.00
CMWW4842P1	1027	1052	48	42	2.3	46	4.63
CMWW4848P1	1178	1208	48	48	2.3	52	5.26
CMWW4854P1	1292	1324	48	54	2.3	59	5.89
CMWW4860P1	1405	1437	48	60	2.3	65	6.53
CMWW5424P1	676	691	54	24	2.3	26	2.73
CMWW5430P1	857	874	54	30	2.3	33	3.37
CMWW5436P1	922	948	54	36	2.3	39	4
CMWW5442P1	1027	1052	54	42	2.3	46	4.63
CMWW5448P1	1178	1208	54	48	2.3	52	5.26
CMWW5454P1	1292	1325	54	54	2.3	59	5.89
CMWW5460P1	1405	1437	54	60	2.3	65	6.53
CMWW6624P1	802	825	66	24	2.3	32	3.58
CMWW6630P1	1003	1030	66	30	2.3	40	4.4
CMWW6636P1	1088	1119	66	36	2.3	48	5.23
CMWW6642P1	1216	1257	66	42	2.3	56	6.06
CMWW6648P1	1378	1419	66	48	2.3	64	6.88
CMWW6654P1	1515	1563	66	54	2.3	72	7.71
CMWW6660P1	1654	1706	66	60	2.3	80	8.53

CMWW-P2 • Single Segmented Powered Write Board Two Sides Panel, Punchouts on Both Sides

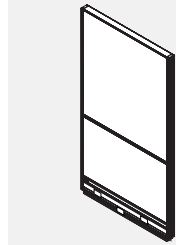

Inside

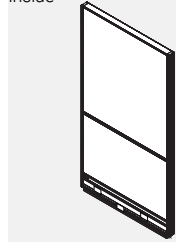

Outside

- Individual fabric or write board covered modules incorporated into an aluminum frame.
- Modules have either write board on two sides at the top and fabric on two sides at the bottom.
- If different grades of fabric are used on one panel, the entire panel must be priced at highest grade.
- Panels are not tackable.
- Note: Trim is not required at a straight connection between two panels of the same height.
- 3 Panel connector brackets per side come standard with 30”h. to 54”h. panels.
- 4 Panel connector brackets per side come standard with 66”h. panels.
- Panels include 2 raceway covers with punchouts on both sides, a power distribution housing, an integrated aluminum top cap and levelling glides.
- 24” wide panels have two punchouts, one for electrical and one for data.
- 30” wide panels and wider have three punchouts, two for electrical and one for data.
- Please specify duplex receptacles separately.

PRODUCT CODE	PRICE		SIZE/ INCHES			WEIGHT VOL	
	GR 1	GR 2	H	W	D	LBS	FT ³
CMWW4824P2	676	691	48	24	2.3	26	2.73
CMWW4830P2	857	873	48	30	2.3	33	3.37
CMWW4836P2	922	948	48	36	2.3	39	4.00
CMWW4842P2	1027	1052	48	42	2.3	46	4.63
CMWW4848P2	1178	1208	48	48	2.3	52	5.26
CMWW4854P2	1292	1324	48	54	2.3	59	5.89
CMWW4860P2	1405	1437	48	60	2.3	65	6.53
CMWW5424P2	676	691	54	24	2.3	26	2.73
CMWW5430P2	857	874	54	30	2.3	33	3.37
CMWW5436P2	922	948	54	36	2.3	39	4
CMWW5442P2	1027	1052	54	42	2.3	46	4.63
CMWW5448P2	1178	1208	54	48	2.3	52	5.26
CMWW5454P2	1292	1325	54	54	2.3	59	5.89
CMWW5460P2	1405	1437	54	60	2.3	65	6.53
CMWW6624P2	802	825	66	24	2.3	32	3.58
CMWW6630P2	1003	1030	66	30	2.3	40	4.4
CMWW6636P2	1088	1119	66	36	2.3	48	5.23
CMWW6642P2	1216	1257	66	42	2.3	56	6.06
CMWW6648P2	1378	1419	66	48	2.3	64	6.88
CMWW6654P2	1515	1563	66	54	2.3	72	7.71
CMWW6660P2	1654	1706	66	60	2.3	80	8.53

CMFG-N0 • Single Glazed, Non Powered Fabric Panel, No Punchouts

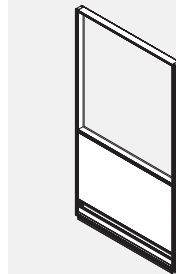

Inside

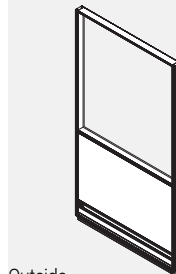

Outside

- Individual fabric-covered module in lower position with glazed module in upper position incorporated into an aluminum frame.
- Opposite sides of each module may have a different fabric within the same grade at no upcharge.
- If different grades of fabric are used on one panel, the entire panel must be priced at highest grade.
- Panels are not tackable.
- Note: Trim is not required at a straight connection between two panels of the same height.
- 3 Panel connector brackets per side come standard with 42”h. and 54”h. panels.
- 4 Panel connector brackets per side come standard with 66”h. panels.
- Panels include 2 raceway covers with no punchouts, an integrated aluminum top cap and levelling glides.
- Standard in clear (CLR) plexi.
- Optional frosted (FRST) plexi
- Glazing starts at 29” high to the top of the panel.

PRODUCT CODE	PRICE		SIZE/ INCHES			WEIGHT VOL	
	GR 1	GR 2	H	W	D	LBS	FT ³
CMFG4224N0	446	459	42	24	2.3	20	2.31
CMFG4230N0	488	507	42	30	2.3	25	2.85
CMFG4236N0	537	567	42	36	2.3	31	3.38
CMFG4242N0	593	625	42	42	2.3	36	3.92
CMFG4248N0	652	681	42	48	2.3	41	4.45
CMFG4254N0	736	765	42	54	2.3	46	4.99
CMFG4260N0	811	840	42	60	2.3	51	5.52
CMFG4824N0	482	495	48	24	2.3	26	2.73
CMFG4830N0	524	542	48	30	2.3	33	3.37
CMFG4836N0	599	629	48	36	2.3	39	4.00
CMFG4842N0	671	700	48	42	2.3	46	4.63
CMFG4848N0	734	763	48	48	2.3	52	5.26
CMFG4854N0	854	885	48	54	2.3	59	5.89
CMFG4860N0	966	997	48	60	2.3	65	6.53
CMFG5424N0	482	495	54	24	2.3	26	2.73
CMFG5430N0	524	542	54	30	2.3	33	3.37
CMFG5436N0	600	629	54	36	2.3	39	4.00
CMFG5442N0	671	699	54	42	2.3	46	4.63
CMFG5448N0	734	763	54	48	2.3	52	5.26
CMFG5454N0	854	885	54	54	2.3	59	5.89
CMFG5460N0	966	997	54	60	2.3	65	6.53
CMFG6624N0	619	633	66	24	2.3	32	3.58
CMFG6630N0	720	734	66	30	2.3	40	4.40
CMFG6636N0	820	851	66	36	2.3	48	5.23
CMFG6642N0	918	949	66	42	2.3	56	6.06
CMFG6648N0	1006	1037	66	48	2.3	64	6.88
CMFG6654N0	1113	1143	66	54	2.3	72	7.71
CMFG6660N0	1212	1243	66	60	2.3	80	8.53

CMFG-N1 • Single Glazed, Non Powered Fabric Panel, Punchouts on One Side

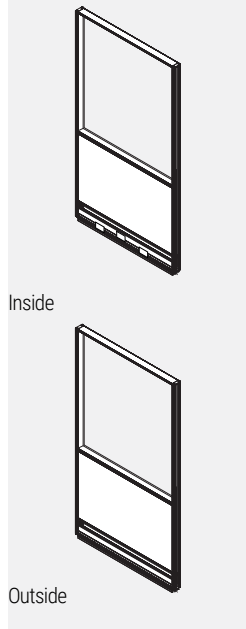

- Individual fabric-covered module in lower position with glazed module in upper position incorporated into an aluminum frame.
- Opposite sides of each module may have a different fabric within the same grade at no upcharge.
- If different grades of fabric are used on one panel, the entire panel must be priced at highest grade.
- Panels are not tackable.
- Note: Trim is not required at a straight connection between two panels of the same height.
- 3 Panel connector brackets per side come standard with 42" h. and 54" h. panels.
- 4 Panel connector brackets per side come standard with 66" h. panels.
- Panels include 1 raceway cover with punchouts on one side, 1 raceway cover with no punchouts on the other, an integrated aluminum top cap and levelling glides.
- Standard in clear (CLR) plexi.
- Optional frosted (FRST) plexi
- 24" wide panels have two punchouts, one for electrical and one for data.
- 30" wide panels and wider have three punchouts, two for electrical and one for data.
- Glazing starts at 29" high to the top of the panel.

PRODUCT CODE	PRICE		SIZE/ INCHES			WEIGHT VOL	
	GR 1	GR 2	H	W	D	LBS	FT ³
CMFG4224N1	446	459	42	24	2.3	20	2.31
CMFG4230N1	488	507	42	30	2.3	25	2.85
CMFG4236N1	537	567	42	36	2.3	31	3.38
CMFG4242N1	593	625	42	42	2.3	36	3.92
CMFG4248N1	652	681	42	48	2.3	41	4.45
CMFG4254N1	736	765	42	54	2.3	46	4.99
CMFG4260N1	811	840	42	60	2.3	51	5.52
CMFG4824N1	482	495	48	24	2.3	26	2.73
CMFG4830N1	524	542	48	30	2.3	33	3.37
CMFG4836N1	599	629	48	36	2.3	39	4.00
CMFG4842N1	671	700	48	42	2.3	46	4.63
CMFG4848N1	734	763	48	48	2.3	52	5.26
CMFG4854N1	854	885	48	54	2.3	59	5.89
CMFG4860N1	966	997	48	60	2.3	65	6.53
CMFG5424N1	482	495	54	24	2.3	26	2.73
CMFG5430N1	524	542	54	30	2.3	33	3.37
CMFG5436N1	600	629	54	36	2.3	39	4.00
CMFG5442N1	671	699	54	42	2.3	46	4.63
CMFG5448N1	734	763	54	48	2.3	52	5.26
CMFG5454N1	854	885	54	54	2.3	59	5.89
CMFG5460N1	966	997	54	60	2.3	65	6.53
CMFG6624N1	619	633	66	24	2.3	32	3.58
CMFG6630N1	720	734	66	30	2.3	40	4.40
CMFG6636N1	820	851	66	36	2.3	48	5.23
CMFG6642N1	918	949	66	42	2.3	56	6.06
CMFG6648N1	1006	1037	66	48	2.3	64	6.88
CMFG6654N1	1113	1143	66	54	2.3	72	7.71
CMFG6660N1	1212	1243	66	60	2.3	80	8.53

CMFG-N2 • Single Glazed, Non Powered Fabric Panel, Punchouts on Both Sides

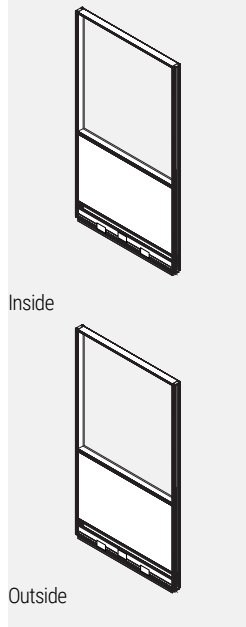

- Individual fabric-covered module in lower position with glazed module in upper position incorporated into an aluminum frame.
- Opposite sides of each module may have a different fabric within the same grade at no upcharge.
- If different grades of fabric are used on one panel, the entire panel must be priced at highest grade.
- Panels are not tackable.
- Note: Trim is not required at a straight connection between two panels of the same height.
- 3 Panel connector brackets per side come standard with 42" h. and 54" h. panels.
- 4 Panel connector brackets per side come standard with 66" h. panels.
- Panels include 2 raceway covers with punchouts on both sides, an integrated aluminum top cap and levelling glides.
- Standard in clear (CLR) plexi.
- Optional frosted (FRST) plexi
- 24" wide panels have two punchouts, one for electrical and one for data.
- 30" wide panels and wider have three punchouts, two for electrical and one for data.
- Glazing starts at 29" high to the top of the panel.

PRODUCT CODE	PRICE		SIZE/ INCHES			WEIGHT VOL	
	GR 1	GR 2	H	W	D	LBS	FT ³
CMFG4224N2	446	459	42	24	2.3	20	2.31
CMFG4230N2	488	507	42	30	2.3	25	2.85
CMFG4236N2	537	567	42	36	2.3	31	3.38
CMFG4242N2	593	625	42	42	2.3	36	3.92
CMFG4248N2	652	681	42	48	2.3	41	4.45
CMFG4254N2	736	765	42	54	2.3	46	4.99
CMFG4260N2	811	840	42	60	2.3	51	5.52
CMFG4824N2	482	495	48	24	2.3	26	2.73
CMFG4830N2	524	542	48	30	2.3	33	3.37
CMFG4836N2	599	629	48	36	2.3	39	4.00
CMFG4842N2	671	700	48	42	2.3	46	4.63
CMFG4848N2	734	763	48	48	2.3	52	5.26
CMFG4854N2	854	885	48	54	2.3	59	5.89
CMFG4860N2	966	997	48	60	2.3	65	6.53
CMFG5424N2	482	495	54	24	2.3	26	2.73
CMFG5430N2	524	542	54	30	2.3	33	3.37
CMFG5436N2	600	629	54	36	2.3	39	4.00
CMFG5442N2	671	699	54	42	2.3	46	4.63
CMFG5448N2	734	763	54	48	2.3	52	5.26
CMFG5454N2	854	885	54	54	2.3	59	5.89
CMFG5460N2	966	997	54	60	2.3	65	6.53
CMFG6624N2	619	633	66	24	2.3	32	3.58
CMFG6630N2	720	734	66	30	2.3	40	4.40
CMFG6636N2	820	851	66	36	2.3	48	5.23
CMFG6642N2	918	949	66	42	2.3	56	6.06
CMFG6648N2	1006	1037	66	48	2.3	64	6.88
CMFG6654N2	1113	1143	66	54	2.3	72	7.71
CMFG6660N2	1212	1243	66	60	2.3	80	8.53

CMFG-P1 • Single Glazed, Powered Fabric Panel, Punchouts on One Side

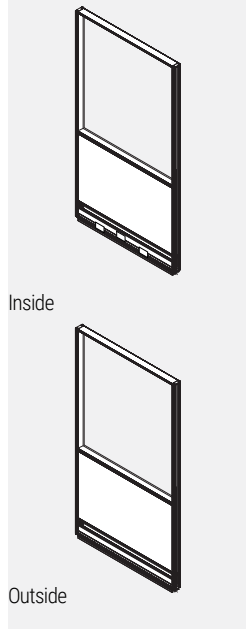

- Individual fabric-covered module in lower position with glazed module in upper position incorporated into an aluminum frame.
- Opposite sides of each module may have a different fabric within the same grade at no upcharge.
- If different grades of fabric are used on one panel, the entire panel must be priced at highest grade.
- Panels are not tackable.
- Note: Trim is not required at a straight connection between two panels of the same height.
- 3 Panel connector brackets per side come standard with 42" h. and 54" h. panels.
- 4 Panel connector brackets per side come standard with 66" h. panels.
- Panels include 1 raceway cover with punchouts on one side, 1 raceway cover with no punchouts on the other, a power distribution housing, an integrated aluminum top cap and levelling glides.
- Standard in clear (CLR) plexi.
- Optional frosted (FRST) plexi
- 24" wide panels have two punchouts, one for electrical and one for data.
- 30" wide panels and wider have three punchouts, two for electrical and one for data.
- Glazing starts at 29" high to the top of the panel.
- Please specify duplex receptacles separately.

PRODUCT CODE	PRICE		SIZE/ INCHES			WEIGHT VOL	
	GR 1	GR 2	H	W	D	LBS	FT ³
CMFG4224P1	582	600	42	24	2.3	20	2.31
CMFG4230P1	678	692	42	30	2.3	25	2.85
CMFG4236P1	731	761	42	36	2.3	31	3.38
CMFG4242P1	796	826	42	42	2.3	36	3.92
CMFG4248P1	864	894	42	48	2.3	41	4.45
CMFG4254P1	954	984	42	54	2.3	46	4.99
CMFG4260P1	1028	1060	42	60	2.3	51	5.52
CMFG4824P1	621	634	48	24	2.3	26	2.73
CMFG4830P1	714	727	48	30	2.3	33	3.37
CMFG4836P1	795	825	48	36	2.3	39	4.00
CMFG4842P1	872	903	48	42	2.3	46	4.63
CMFG4848P1	949	977	48	48	2.3	52	5.26
CMFG4854P1	1072	1102	48	54	2.3	59	5.89
CMFG4860P1	1186	1214	48	60	2.3	65	6.53
CMFG5424P1	621	634	54	24	2.3	26	2.73
CMFG5430P1	714	726	54	30	2.3	33	3.37
CMFG5436P1	794	825	54	36	2.3	39	4.00
CMFG5442P1	872	903	54	42	2.3	46	4.63
CMFG5448P1	949	977	54	48	2.3	52	5.26
CMFG5454P1	1072	1102	54	54	2.3	59	5.89
CMFG5460P1	1186	1214	54	60	2.3	65	6.53
CMFG6624P1	757	774	66	24	2.3	32	3.58
CMFG6630P1	907	921	66	30	2.3	40	4.40
CMFG6636P1	1017	1046	66	36	2.3	48	5.23
CMFG6642P1	1121	1152	66	42	2.3	56	6.06
CMFG6648P1	1223	1254	66	48	2.3	64	6.88
CMFG6654P1	1329	1360	66	54	2.3	72	7.71
CMFG6660P1	1434	1463	66	60	2.3	80	8.53

CMFG-P2 • Single Glazed, Powered Fabric Panel, Punchouts on Both Sides

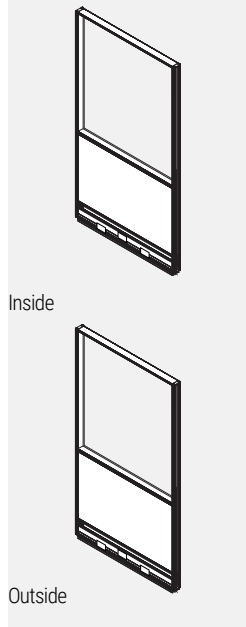

- Individual fabric-covered module in lower position with glazed module in upper position incorporated into a aluminum frame.
- Opposite sides of each module may have a different fabric within the same grade at no upcharge.
- If different grades of fabric are used on one panel, the entire panel must be priced at highest grade.
- Panels are not tackable.
- Note: Trim is not required at a straight connection between two panels of the same height.
- 3 Panel connector brackets per side come standard with 42" h. and 54" h. panels.
- 4 Panel connector brackets per side come standard with 66" h. panels.
- Panels include 2 raceway covers with punchouts on both sides, a power distribution housing, an integrated aluminum top cap and levelling glides.
- Standard in clear (CLR) plexi.
- Optional frosted (FRST) plexi
- 24" wide panels have two punchouts, one for electrical and one for data.
- 30" wide panels and wider have three punchouts, two for electrical and one for data.
- Glazing starts at 29" high to the top of the panel.
- Please specify duplex receptacles separately.

PRODUCT CODE	PRICE		SIZE/ INCHES			WEIGHT VOL	
	GR 1	GR 2	H	W	D	LBS	FT ³
CMFG4224P2	582	600	42	24	2.3	20	2.31
CMFG4230P2	678	692	42	30	2.3	25	2.85
CMFG4236P2	731	761	42	36	2.3	31	3.38
CMFG4242P2	796	826	42	42	2.3	36	3.92
CMFG4248P2	864	894	42	48	2.3	41	4.45
CMFG4254P2	954	984	42	54	2.3	46	4.99
CMFG4260P2	1028	1060	42	60	2.3	51	5.52
CMFG4824P2	621	634	48	24	2.3	26	2.73
CMFG4830P2	714	727	48	30	2.3	33	3.37
CMFG4836P2	795	825	48	36	2.3	39	4.00
CMFG4842P2	872	903	48	42	2.3	46	4.63
CMFG4848P2	949	977	48	48	2.3	52	5.26
CMFG4854P2	1072	1102	48	54	2.3	59	5.89
CMFG4860P2	1186	1214	48	60	2.3	65	6.53
CMFG5424P2	621	634	54	24	2.3	26	2.73
CMFG5430P2	714	726	54	30	2.3	33	3.37
CMFG5436P2	794	825	54	36	2.3	39	4.00
CMFG5442P2	872	903	54	42	2.3	46	4.63
CMFG5448P2	949	977	54	48	2.3	52	5.26
CMFG5454P2	1072	1102	54	54	2.3	59	5.89
CMFG5460P2	1186	1214	54	60	2.3	65	6.53
CMFG6624P2	757	774	66	24	2.3	32	3.58
CMFG6630P2	907	921	66	30	2.3	40	4.40
CMFG6636P2	1017	1046	66	36	2.3	48	5.23
CMFG6642P2	1121	1152	66	42	2.3	56	6.06
CMFG6648P2	1223	1254	66	48	2.3	64	6.88
CMFG6654P2	1329	1360	66	54	2.3	72	7.71
CMFG6660P2	1434	1463	66	60	2.3	80	8.53

CMPLG-N0 • Single 12" Glazed at top, Non Powered Fabric Panel, No Punchouts

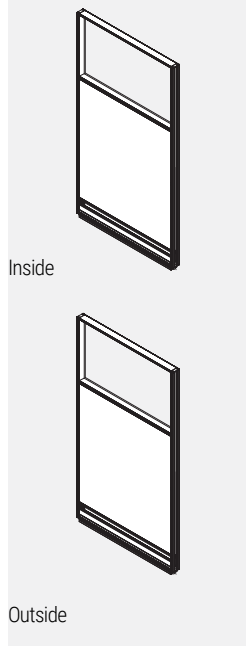

- Individual fabric-covered module in lower position with glazed module in upper position incorporated into an aluminum frame.
- Opposite sides of each module may have a different fabric within the same grade at no upcharge.
- If different grades of fabric are used on one panel, the entire panel must be priced at highest grade.
- Panels are not tackable.
- Note: Trim is not required at a straight connection between two panels of the same height.
- 3 Panel connector brackets per side come standard with 42"h. and 54"h. panels.
- 4 Panel connector brackets per side come standard with 66"h. panels.
- Panels include 2 raceway covers with no punchouts, an integrated aluminum top cap and levelling glides.
- Standard in clear (CLR) plexi.
- Optional frosted (FRST) plexi
- Glazing is 12" nominal from the top of the panel.

PRODUCT CODE	PRICE		SIZE/ INCHES			WEIGHT VOL	
	GR 1	GR 2	H	W	D	LBS	FT ³
CMPLG4224N0	446	459	42	24	2.3	20	2.31
CMPLG4230N0	488	507	42	30	2.3	25	2.85
CMPLG4236N0	537	567	42	36	2.3	31	3.38
CMPLG4242N0	593	625	42	42	2.3	36	3.92
CMPLG4248N0	652	681	42	48	2.3	41	4.45
CMPLG4254N0	736	765	42	54	2.3	46	4.99
CMPLG4260N0	811	840	42	60	2.3	51	5.52
CMPLG4824N0	477	491	48	24	2.3	26	2.73
CMPLG4830N0	550	567	48	30	2.3	33	3.37
CMPLG4836N0	613	644	48	36	2.3	39	4.00
CMPLG4842N0	690	720	48	42	2.3	46	4.63
CMPLG4848N0	759	790	48	48	2.3	52	5.26
CMPLG4854N0	839	870	48	54	2.3	59	5.89
CMPLG4860N0	913	941	48	60	2.3	65	6.53
CMPLG5424N0	477	490	54	24	2.3	26	2.73
CMPLG5430N0	550	567	54	30	2.3	33	3.37
CMPLG5436N0	613	644	54	36	2.3	39	4.00
CMPLG5442N0	689	720	54	42	2.3	46	4.63
CMPLG5448N0	759	790	54	48	2.3	52	5.26
CMPLG5454N0	840	869	54	54	2.3	59	5.89
CMPLG5460N0	913	942	54	60	2.3	65	6.53
CMPLG6624N0	524	555	66	24	2.3	32	3.58
CMPLG6630N0	608	638	66	30	2.3	40	4.40
CMPLG6636N0	676	736	66	36	2.3	48	5.23
CMPLG6642N0	754	814	66	42	2.3	56	6.06
CMPLG6648N0	833	894	66	48	2.3	64	6.88
CMPLG6654N0	920	982	66	54	2.3	72	7.71
CMPLG6660N0	999	1061	66	60	2.3	80	8.53

CMPLG-N1 • Single 12" Glazed at top, Non Powered Panel, Punchouts on One Side

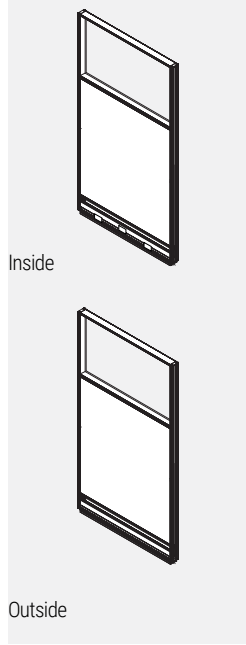

- Individual fabric-covered module in lower position with glazed module in upper position incorporated into an aluminum frame.
- Opposite sides of each module may have a different fabric within the same grade at no upcharge.
- If different grades of fabric are used on one panel, the entire panel must be priced at highest grade.
- Panels are not tackable.
- Note: Trim is not required at a straight connection between two panels of the same height.
- 3 Panel connector brackets per side come standard with 42"h. and 54"h. panels.
- 4 Panel connector brackets per side come standard with 66"h. panels.
- Panels include 1 raceway cover with punchouts on one side, 1 raceway cover with no punchouts on the other, an integrated aluminum top cap and levelling glides.
- Standard in clear (CLR) plexi.
- Optional frosted (FRST) plexi
- 24" wide panels have two punchouts, one for electrical and one for data.
- 30" wide panels and wider have three punchouts, two for electrical and one for data.
- Glazing is 12" nominal from the top of the panel.

PRODUCT CODE	PRICE		SIZE/ INCHES			WEIGHT VOL	
	GR 1	GR 2	H	W	D	LBS	FT ³
CMPLG4224N1	446	459	42	24	2.3	20	2.31
CMPLG4230N1	488	507	42	30	2.3	25	2.85
CMPLG4236N1	537	567	42	36	2.3	31	3.38
CMPLG4242N1	593	625	42	42	2.3	36	3.92
CMPLG4248N1	652	681	42	48	2.3	41	4.45
CMPLG4254N1	736	765	42	54	2.3	46	4.99
CMPLG4260N1	811	840	42	60	2.3	51	5.52
CMPLG4824N1	477	491	48	24	2.3	26	2.73
CMPLG4830N1	550	567	48	30	2.3	33	3.37
CMPLG4836N1	613	644	48	36	2.3	39	4.00
CMPLG4842N1	690	720	48	42	2.3	46	4.63
CMPLG4848N1	759	790	48	48	2.3	52	5.26
CMPLG4854N1	839	870	48	54	2.3	59	5.89
CMPLG4860N1	913	941	48	60	2.3	65	6.53
CMPLG5424N1	477	490	54	24	2.3	26	2.73
CMPLG5430N1	550	567	54	30	2.3	33	3.37
CMPLG5436N1	613	644	54	36	2.3	39	4.00
CMPLG5442N1	689	720	54	42	2.3	46	4.63
CMPLG5448N1	759	790	54	48	2.3	52	5.26
CMPLG5454N1	840	869	54	54	2.3	59	5.89
CMPLG5460N1	913	942	54	60	2.3	65	6.53
CMPLG6624N1	524	555	66	24	2.3	32	3.58
CMPLG6630N1	608	638	66	30	2.3	40	4.40
CMPLG6636N1	676	736	66	36	2.3	48	5.23
CMPLG6642N1	754	814	66	42	2.3	56	6.06
CMPLG6648N1	833	894	66	48	2.3	64	6.88
CMPLG6654N1	920	982	66	54	2.3	72	7.71
CMPLG6660N1	999	1061	66	60	2.3	80	8.53

CMPLG-N2 • Single 12" at Top, Non Powered Fabric Panel, Punchouts on Both Sides

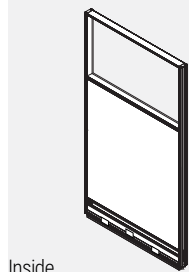

Inside

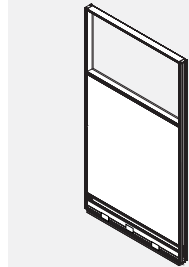

Outside

- Individual fabric-covered module in lower position with glazed module in upper position incorporated into a solid steel frame.
- Opposite sides of each module may have a different fabric within the same grade at no upcharge.
- If different grades of fabric are used on one panel, the entire panel must be priced at highest grade.
- Panels are not tackable.
- Note: Trim is not required at a straight connection between two panels of the same height.
- 3 Panel connector brackets per side come standard with 42"h. and 54"h. panels.
- 4 Panel connector brackets per side come standard with 66"h. panels.
- Panels include 2 raceway covers with punchouts on both sides, an integrated aluminum top cap and levelling glides.
- Standard in clear (CLR) plexi.
- Optional frosted (FRST) plexi
- 24" wide panels have two punchouts, one for electrical and one for data.
- 30" wide panels and wider have three punchouts, two for electrical and one for data.
- Glazing is 12" nominal from the top of the panel.

PRODUCT CODE	PRICE		SIZE/ INCHES			WEIGHT VOL	
	GR 1	GR 2	H	W	D	LBS	FT ³
CMPLG4224N2	446	459	42	24	2.3	20	2.31
CMPLG4230N2	488	507	42	30	2.3	25	2.85
CMPLG4236N2	537	567	42	36	2.3	31	3.38
CMPLG4242N2	593	625	42	42	2.3	36	3.92
CMPLG4248N2	652	681	42	48	2.3	41	4.45
CMPLG4254N2	736	765	42	54	2.3	46	4.99
CMPLG4260N2	811	840	42	60	2.3	51	5.52
CMPLG4824N2	477	491	48	24	2.3	26	2.73
CMPLG4830N2	550	567	48	30	2.3	33	3.37
CMPLG4836N2	613	644	48	36	2.3	39	4.00
CMPLG4842N2	690	720	48	42	2.3	46	4.63
CMPLG4848N2	759	790	48	48	2.3	52	5.26
CMPLG4854N2	839	870	48	54	2.3	59	5.89
CMPLG4860N2	913	941	48	60	2.3	65	6.53
CMPLG5424N2	477	490	54	24	2.3	26	2.73
CMPLG5430N2	550	567	54	30	2.3	33	3.37
CMPLG5436N2	613	644	54	36	2.3	39	4.00
CMPLG5442N2	689	720	54	42	2.3	46	4.63
CMPLG5448N2	759	790	54	48	2.3	52	5.26
CMPLG5454N2	840	869	54	54	2.3	59	5.89
CMPLG5460N2	913	942	54	60	2.3	65	6.53
CMPLG6624N2	524	555	66	24	2.3	32	3.58
CMPLG6630N2	608	638	66	30	2.3	40	4.40
CMPLG6636N2	676	736	66	36	2.3	48	5.23
CMPLG6642N2	754	814	66	42	2.3	56	6.06
CMPLG6648N2	833	894	66	48	2.3	64	6.88
CMPLG6654N2	920	982	66	54	2.3	72	7.71
CMPLG6660N2	999	1061	66	60	2.3	80	8.53

CMPLG-P1 • Single 12" Glazed at Top, Powered Fabric Panel, Punchouts on One Side

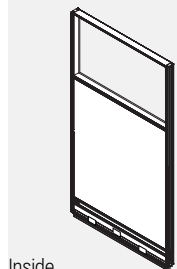

Inside

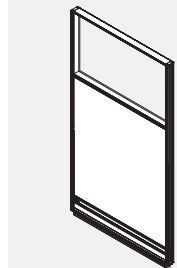

Outside

- Individual fabric-covered module in lower position with glazed module in upper position incorporated into a solid steel frame.
- Opposite sides of each module may have a different fabric within the same grade at no upcharge.
- If different grades of fabric are used on one panel, the entire panel must be priced at highest grade.
- Panels are not tackable.
- Note: Trim is not required at a straight connection between two panels of the same height.
- 3 Panel connector brackets per side come standard with 42"h. and 54"h. panels.
- 4 Panel connector brackets per side come standard with 66"h. panels.
- Panels include 1 raceway cover with punchouts on one side, 1 raceway cover with no punchouts on the other, a power distribution housing, an integrated aluminum top cap and levelling glides.
- Standard in clear (CLR) plexi.
- Optional frosted (FRST) plexi
- 24" wide panels have two punchouts, one for electrical and one for data.
- 30" wide panels and wider have three punchouts, two for electrical and one for data.
- Please specify duplex receptacles separately.
- Glazing is 12" nominal from the top of the panel.

PRODUCT CODE	PRICE		SIZE/ INCHES			WEIGHT VOL	
	GR 1	GR 2	H	W	D	LBS	FT ³
CMPLG4224P1	582	600	42	24	2.3	20	2.31
CMPLG4230P1	678	692	42	30	2.3	25	2.85
CMPLG4236P1	731	761	42	36	2.3	31	3.38
CMPLG4242P1	796	826	42	42	2.3	36	3.92
CMPLG4248P1	864	894	42	48	2.3	41	4.45
CMPLG4254P1	954	984	42	54	2.3	46	4.99
CMPLG4260P1	1028	1060	42	60	2.3	51	5.52
CMPLG4824P1	614	630	48	24	2.3	26	2.73
CMPLG4830P1	737	752	48	30	2.3	33	3.37
CMPLG4836P1	809	839	48	36	2.3	39	4.00
CMPLG4842P1	892	921	48	42	2.3	46	4.63
CMPLG4848P1	974	1004	48	48	2.3	52	5.26
CMPLG4854P1	1057	1087	48	54	2.3	59	5.89
CMPLG4860P1	1131	1160	48	60	2.3	65	6.53
CMPLG5424P1	614	630	54	24	2.3	26	2.73
CMPLG5430P1	737	752	54	30	2.3	33	3.37
CMPLG5436P1	811	840	54	36	2.3	39	4.00
CMPLG5442P1	892	921	54	42	2.3	46	4.63
CMPLG5448P1	973	1003	54	48	2.3	52	5.26
CMPLG5454P1	1057	1088	54	54	2.3	59	5.89
CMPLG5460P1	1131	1160	54	60	2.3	65	6.53
CMPLG6624P1	665	694	66	24	2.3	32	3.58
CMPLG6630P1	794	825	66	30	2.3	40	4.40
CMPLG6636P1	870	931	66	36	2.3	48	5.23
CMPLG6642P1	956	1017	66	42	2.3	56	6.06
CMPLG6648P1	1050	1108	66	48	2.3	64	6.88
CMPLG6654P1	1137	1198	66	54	2.3	72	7.71
CMPLG6660P1	1218	1278	66	60	2.3	80	8.53

CMPLG-P2 • Single 12" Glazed at Top, Powered Fabric Panel, Punchouts on Both Sides

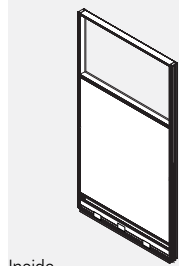

Inside

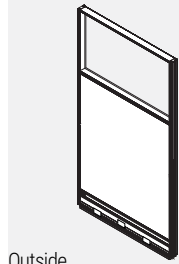

Outside

- Individual fabric-covered module in lower position with glazed module in upper position incorporated into an aluminum frame.
- Opposite sides of each module may have a different fabric within the same grade at no upcharge.
- If different grades of fabric are used on one panel, the entire panel must be priced at highest grade.
- Panels are not tackable.
- Note: Trim is not required at a straight connection between two panels of the same height.
- 3 Panel connector brackets per side come standard with 42"h. and 54"h. panels.
- 4 Panel connector brackets per side come standard with 66"h. panels.
- Panels include 2 raceway covers with punchouts on both sides, a power distribution housing, an integrated aluminum top cap and levelling glides.
- Standard in clear (CLR) plexi.
- Optional frosted (FRST) plexi
- 24" wide panels have two punchouts, one for electrical and one for data.
- 30" wide panels and wider have three punchouts, two for electrical and one for data.
- Glazing is 12" nominal from the top of the panel. panels and wider have 2 punchouts.
- Please specify duplex receptacles separately.

PRODUCT CODE	PRICE		SIZE/ H	INCHES			WEIGHT VOL	
	GR 1	GR 2		W	D	LBS	FT³	
CMPLG4224P2	582	600	42	24	2.3	20	2.31	
CMPLG4230P2	678	692	42	30	2.3	25	2.85	
CMPLG4236P2	731	761	42	36	2.3	31	3.38	
CMPLG4242P2	796	826	42	42	2.3	36	3.92	
CMPLG4248P2	864	894	42	48	2.3	41	4.45	
CMPLG4254P2	954	984	42	54	2.3	46	4.99	
CMPLG4260P2	1028	1060	42	60	2.3	51	5.52	
CMPLG4824P2	614	630	48	24	2.3	26	2.73	
CMPLG4830P2	737	752	48	30	2.3	33	3.37	
CMPLG4836P2	809	839	48	36	2.3	39	4.00	
CMPLG4842P2	892	921	48	42	2.3	46	4.63	
CMPLG4848P2	974	1004	48	48	2.3	52	5.26	
CMPLG4854P2	1057	1087	48	54	2.3	59	5.89	
CMPLG4860P2	1131	1160	48	60	2.3	65	6.53	
CMPLG5424P2	614	630	54	24	2.3	26	2.73	
CMPLG5430P2	737	752	54	30	2.3	33	3.37	
CMPLG5436P2	811	840	54	36	2.3	39	4.00	
CMPLG5442P2	892	921	54	42	2.3	46	4.63	
CMPLG5448P2	973	1003	54	48	2.3	52	5.26	
CMPLG5454P2	1057	1088	54	54	2.3	59	5.89	
CMPLG5460P2	1131	1160	54	60	2.3	65	6.53	
CMPLG6624P2	665	694	66	24	2.3	32	3.58	
CMPLG6630P2	794	825	66	30	2.3	40	4.40	
CMPLG6636P2	870	931	66	36	2.3	48	5.23	
CMPLG6642P2	956	1017	66	42	2.3	56	6.06	
CMPLG6648P2	1050	1108	66	48	2.3	64	6.88	
CMPLG6654P2	1137	1198	66	54	2.3	72	7.71	
CMPLG6660P2	1218	1278	66	60	2.3	80	8.53	

CMPG-N0 • Single 14" Glazed at Top Glazed Panel, Non Powered Fabric Panel, No Punchouts

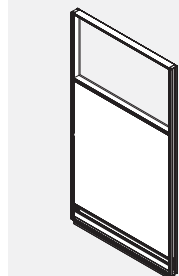

Inside

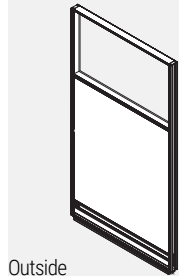

Outside

- Individual fabric-covered module in lower position with glazed module in upper position incorporated into an aluminum frame.
- Opposite sides of each module may have a different fabric within the same grade at no upcharge.
- If different grades of fabric are used on one panel, the entire panel must be priced at highest grade.
- Panels are not tackable.
- Note: Trim is not required at a straight connection between two panels of the same height.
- 3 Panel connector brackets per side come standard with 42"h. and 54"h. panels.
- 4 Panel connector brackets per side come standard with 66"h. panels.
- Panels include 2 raceway covers with no punchouts, an integrated aluminum top cap and levelling glides.
- Standard in clear (CLR) plexi.
- Optional frosted (FRST) plexi
- PVC Glass Retainer may match any panel frame finish.
- Glazing is 14" nominal from the top of the panel.

PRODUCT CODE	PRICE		SIZE/ H	INCHES			WEIGHT VOL	
	GR 1	GR 2		W	D	LBS	FT³	
CMPG4224N0	446	459	42	24	2.3	20	2.31	
CMPG4230N0	488	507	42	30	2.3	25	2.85	
CMPG4236N0	537	567	42	36	2.3	31	3.38	
CMPG4242N0	593	625	42	42	2.3	36	3.92	
CMPG4248N0	652	681	42	48	2.3	41	4.45	
CMPG4254N0	736	765	42	54	2.3	46	4.99	
CMPG4260N0	811	840	42	60	2.3	51	5.52	
CMPG4824N0	477	491	48	24	2.3	26	2.73	
CMPG4830N0	550	567	48	30	2.3	33	3.37	
CMPG4836N0	613	644	48	36	2.3	39	4.00	
CMPG4842N0	690	720	48	42	2.3	46	4.63	
CMPG4848N0	759	790	48	48	2.3	52	5.26	
CMPG4854N0	839	870	48	54	2.3	59	5.89	
CMPG4860N0	913	941	48	60	2.3	65	6.53	
CMPG5424N0	477	490	54	24	2.3	26	2.73	
CMPG5430N0	550	567	54	30	2.3	33	3.37	
CMPG5436N0	613	644	54	36	2.3	39	4.00	
CMPG5442N0	689	720	54	42	2.3	46	4.63	
CMPG5448N0	759	790	54	48	2.3	52	5.26	
CMPG5454N0	840	869	54	54	2.3	59	5.89	
CMPG5460N0	913	942	54	60	2.3	65	6.53	
CMPG6624N0	524	555	66	24	2.3	32	3.58	
CMPG6630N0	608	638	66	30	2.3	40	4.40	
CMPG6636N0	676	736	66	36	2.3	48	5.23	
CMPG6642N0	754	814	66	42	2.3	56	6.06	
CMPG6648N0	833	894	66	48	2.3	64	6.88	
CMPG6654N0	920	982	66	54	2.3	72	7.71	
CMPG6660N0	999	1061	66	60	2.3	80	8.53	

CMPG-N1 • Single 14" Glazed at Top Glazed Panel, Non Powered Fabric Panel, Punchouts on One Side

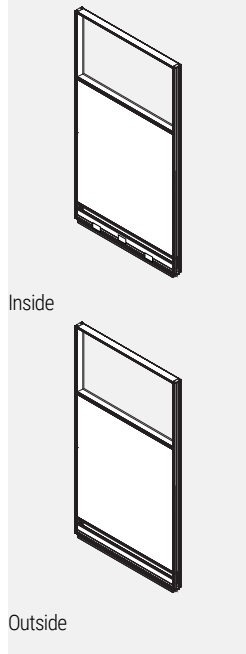

- Individual fabric-covered module in lower position with glazed module in upper position incorporated into an aluminum frame.
- Opposite sides of each module may have a different fabric within the same grade at no upcharge.
- If different grades of fabric are used on one panel, the entire panel must be priced at highest grade.
- Panels are not tackable.
- Note: Trim is not required at a straight connection between two panels of the same height.
- 3 Panel connector brackets per side come standard with 42"h. and 54"h. panels.
- 4 Panel connector brackets per side come standard with 66"h. panels.
- Panels include 1 raceway cover with punchouts on one side, 1 raceway cover with no punchouts on the other, an integrated aluminum top cap and levelling glides.
- Standard in clear (CLR) plexi.
- Optional frosted (FRST) plexi
- 24" wide panels have two punchouts, one for electrical and one for data.
- 30" wide panels and wider have three punchouts, two for electrical and one for data.
- Glazing is 14" nominal from the top of the panel.

PRODUCT CODE	PRICE		SIZE/ INCHES			WEIGHT VOL	
	GR 1	GR 2	H	W	D	LBS	FT³
CMPG4224N1	446	459	42	24	2.3	20	2.31
CMPG4230N1	488	507	42	30	2.3	25	2.85
CMPG4236N1	537	567	42	36	2.3	31	3.38
CMPG4242N1	593	625	42	42	2.3	36	3.92
CMPG4248N1	652	681	42	48	2.3	41	4.45
CMPG4254N1	736	765	42	54	2.3	46	4.99
CMPG4260N1	811	840	42	60	2.3	51	5.52
CMPG4824N1	477	491	48	24	2.3	26	2.73
CMPG4830N1	550	567	48	30	2.3	33	3.37
CMPG4836N1	613	644	48	36	2.3	39	4.00
CMPG4842N1	690	720	48	42	2.3	46	4.63
CMPG4848N1	759	790	48	48	2.3	52	5.26
CMPG4854N1	839	870	48	54	2.3	59	5.89
CMPG4860N1	913	941	48	60	2.3	65	6.53
CMPG5424N1	477	490	54	24	2.3	26	2.73
CMPG5430N1	550	567	54	30	2.3	33	3.37
CMPG5436N1	613	644	54	36	2.3	39	4.00
CMPG5442N1	689	720	54	42	2.3	46	4.63
CMPG5448N1	759	790	54	48	2.3	52	5.26
CMPG5454N1	840	869	54	54	2.3	59	5.89
CMPG5460N1	913	942	54	60	2.3	65	6.53
CMPG6624N1	524	555	66	24	2.3	32	3.58
CMPG6630N1	608	638	66	30	2.3	40	4.40
CMPG6636N1	676	736	66	36	2.3	48	5.23
CMPG6642N1	754	814	66	42	2.3	56	6.06
CMPG6648N1	833	894	66	48	2.3	64	6.88
CMPG6654N1	920	982	66	54	2.3	72	7.71
CMPG6660N1	999	1061	66	60	2.3	80	8.53

CMPG-N2 • Single 14" Glazed at Top, Non Powered Fabric Panel, Punchouts on Both Sides

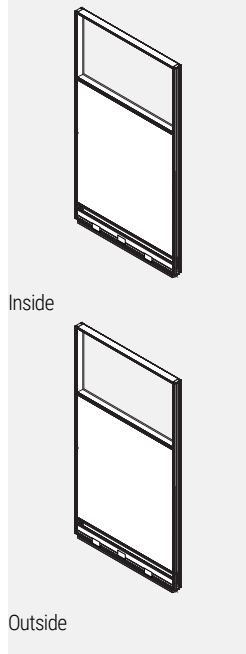

- Individual fabric-covered module in lower position with glazed module in upper position incorporated into a solid steel frame.
- Opposite sides of each module may have a different fabric within the same grade at no upcharge.
- If different grades of fabric are used on one panel, the entire panel must be priced at highest grade.
- Panels are not tackable.
- Note: Trim is not required at a straight connection between two panels of the same height.
- 3 Panel connector brackets per side come standard with 42"h. and 54"h. panels.
- 4 Panel connector brackets per side come standard with 66"h. panels.
- Panels include 2 raceway covers with punchouts on both sides, an integrated aluminum top cap and levelling glides.
- Standard in clear (CLR) plexi.
- Optional frosted (FRST) plexi
- 24" wide panels have two punchouts, one for electrical and one for data.
- 30" wide panels and wider have three punchouts, two for electrical and one for data.
- Glazing is 14" nominal from the top of the panel.

PRODUCT CODE	PRICE		SIZE/ INCHES			WEIGHT VOL	
	GR 1	GR 2	H	W	D	LBS	FT³
CMPG4224N2	446	459	42	24	2.3	20	2.31
CMPG4230N2	488	507	42	30	2.3	25	2.85
CMPG4236N2	537	567	42	36	2.3	31	3.38
CMPG4242N2	593	625	42	42	2.3	36	3.92
CMPG4248N2	652	681	42	48	2.3	41	4.45
CMPG4254N2	736	765	42	54	2.3	46	4.99
CMPG4260N2	811	840	42	60	2.3	51	5.52
CMPG4824N2	477	491	48	24	2.3	26	2.73
CMPG4830N2	550	567	48	30	2.3	33	3.37
CMPG4836N2	613	644	48	36	2.3	39	4.00
CMPG4842N2	690	720	48	42	2.3	46	4.63
CMPG4848N2	759	790	48	48	2.3	52	5.26
CMPG4854N2	839	870	48	54	2.3	59	5.89
CMPG4860N2	913	941	48	60	2.3	65	6.53
CMPG5424N2	477	490	54	24	2.3	26	2.73
CMPG5430N2	550	567	54	30	2.3	33	3.37
CMPG5436N2	613	644	54	36	2.3	39	4.00
CMPG5442N2	689	720	54	42	2.3	46	4.63
CMPG5448N2	759	790	54	48	2.3	52	5.26
CMPG5454N2	840	869	54	54	2.3	59	5.89
CMPG5460N2	913	942	54	60	2.3	65	6.53
CMPG6624N2	524	555	66	24	2.3	32	3.58
CMPG6630N2	608	638	66	30	2.3	40	4.40
CMPG6636N2	676	736	66	36	2.3	48	5.23
CMPG6642N2	754	814	66	42	2.3	56	6.06
CMPG6648N2	833	894	66	48	2.3	64	6.88
CMPG6654N2	920	982	66	54	2.3	72	7.71
CMPG6660N2	999	1061	66	60	2.3	80	8.53

CMPG-P1 • Single 14" Glazed at Top, Powered Fabric Panel, Punchouts on One Side

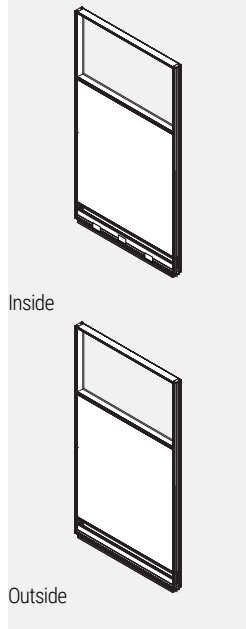

- Individual fabric-covered module in lower position with glazed module in upper position incorporated into a solid steel frame.
- Opposite sides of each module may have a different fabric within the same grade at no upcharge.
- If different grades of fabric are used on one panel, the entire panel must be priced at highest grade.
- Panels are not tackable.
- Note: Trim is not required at a straight connection between two panels of the same height.
- 3 Panel connector brackets per side come standard with 42"h. and 54"h. panels.
- 4 Panel connector brackets per side come standard with 66"h. panels.
- Panels include 1 raceway cover with punchouts on one side, 1 raceway cover with no punchouts on the other, a power distribution housing, an integrated aluminum top cap and levelling glides.
- Standard in clear (CLR) plexi.
- Optional frosted (FRST) plexi
- 24" wide panels have two punchouts, one for electrical and one for data.
- 30" wide panels and wider have three punchouts, two for electrical and one for data.
- Please specify duplex receptacles separately.
- Glazing is 14" nominal from the top of the panel.

PRODUCT CODE	PRICE		SIZE/ H	INCHES			WEIGHT VOL	
	GR 1	GR 2		W	D	LBS	FT ³	
CMPG4224P1	582	600	42	24	2.3	20	2.31	
CMPG4230P1	678	692	42	30	2.3	25	2.85	
CMPG4236P1	731	761	42	36	2.3	31	3.38	
CMPG4242P1	796	826	42	42	2.3	36	3.92	
CMPG4248P1	864	894	42	48	2.3	41	4.45	
CMPG4254P1	954	984	42	54	2.3	46	4.99	
CMPG4260P1	1028	1060	42	60	2.3	51	5.52	
CMPG4824P1	614	630	48	24	2.3	26	2.73	
CMPG4830P1	737	752	48	30	2.3	33	3.37	
CMPG4836P1	809	839	48	36	2.3	39	4.00	
CMPG4842P1	892	921	48	42	2.3	46	4.63	
CMPG4848P1	974	1004	48	48	2.3	52	5.26	
CMPG4854P1	1057	1087	48	54	2.3	59	5.89	
CMPG4860P1	1131	1160	48	60	2.3	65	6.53	
CMPG5424P1	614	630	54	24	2.3	26	2.73	
CMPG5430P1	737	752	54	30	2.3	33	3.37	
CMPG5436P1	811	840	54	36	2.3	39	4.00	
CMPG5442P1	892	921	54	42	2.3	46	4.63	
CMPG5448P1	973	1003	54	48	2.3	52	5.26	
CMPG5454P1	1057	1088	54	54	2.3	59	5.89	
CMPG5460P1	1131	1160	54	60	2.3	65	6.53	
CMPG6624P1	665	694	66	24	2.3	32	3.58	
CMPG6630P1	794	825	66	30	2.3	40	4.40	
CMPG6636P1	870	931	66	36	2.3	48	5.23	
CMPG6642P1	956	1017	66	42	2.3	56	6.06	
CMPG6648P1	1050	1108	66	48	2.3	64	6.88	
CMPG6654P1	1137	1198	66	54	2.3	72	7.71	
CMPG6660P1	1218	1278	66	60	2.3	80	8.53	

CMPG-P2 • Single 14" Glazed at Top, Powered Fabric Panel, Punchouts on Both Sides

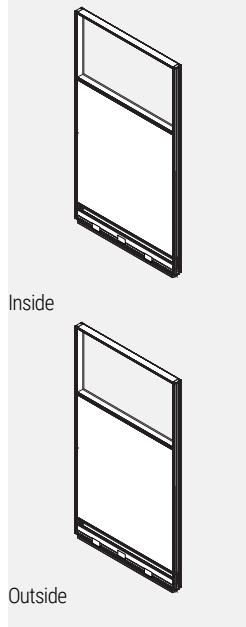

- Individual fabric-covered module in lower position with glazed module in upper position incorporated into an aluminum frame.
- Opposite sides of each module may have a different fabric within the same grade at no upcharge.
- If different grades of fabric are used on one panel, the entire panel must be priced at highest grade.
- Panels are not tackable.
- Note: Trim is not required at a straight connection between two panels of the same height.
- 3 Panel connector brackets per side come standard with 42"h. and 54"h. panels.
- 4 Panel connector brackets per side come standard with 66"h. panels.
- Panels include 2 raceway covers with punchouts on both sides, a power distribution housing, an integrated aluminum top cap and levelling glides.
- Standard in clear (CLR) plexi.
- Optional frosted (FRST) plexi
- 24" wide panels have two punchouts, one for electrical and one for data.
- 30" wide panels and wider have three punchouts, two for electrical and one for data.
- Glazing is 14" nominal from the top of the panel. panels and wider have 2 punchouts.
- Please specify duplex receptacles separately.

PRODUCT CODE	PRICE		SIZE/ H	INCHES			WEIGHT VOL	
	GR 1	GR 2		W	D	LBS	FT ³	
CMPG4224P2	582	600	42	24	2.3	20	2.31	
CMPG4230P2	678	692	42	30	2.3	25	2.85	
CMPG4236P2	731	761	42	36	2.3	31	3.38	
CMPG4242P2	796	826	42	42	2.3	36	3.92	
CMPG4248P2	864	894	42	48	2.3	41	4.45	
CMPG4254P2	954	984	42	54	2.3	46	4.99	
CMPG4260P2	1028	1060	42	60	2.3	51	5.52	
CMPG4824P2	614	630	48	24	2.3	26	2.73	
CMPG4830P2	737	752	48	30	2.3	33	3.37	
CMPG4836P2	809	839	48	36	2.3	39	4.00	
CMPG4842P2	892	921	48	42	2.3	46	4.63	
CMPG4848P2	974	1004	48	48	2.3	52	5.26	
CMPG4854P2	1057	1087	48	54	2.3	59	5.89	
CMPG4860P2	1131	1160	48	60	2.3	65	6.53	
CMPG5424P2	614	630	54	24	2.3	26	2.73	
CMPG5430P2	737	752	54	30	2.3	33	3.37	
CMPG5436P2	811	840	54	36	2.3	39	4.00	
CMPG5442P2	892	921	54	42	2.3	46	4.63	
CMPG5448P2	973	1003	54	48	2.3	52	5.26	
CMPG5454P2	1057	1088	54	54	2.3	59	5.89	
CMPG5460P2	1131	1160	54	60	2.3	65	6.53	
CMPG6624P2	665	694	66	24	2.3	32	3.58	
CMPG6630P2	794	825	66	30	2.3	40	4.40	
CMPG6636P2	870	931	66	36	2.3	48	5.23	
CMPG6642P2	956	1017	66	42	2.3	56	6.06	
CMPG6648P2	1050	1108	66	48	2.3	64	6.88	
CMPG6654P2	1137	1198	66	54	2.3	72	7.71	
CMPG6660P2	1218	1278	66	60	2.3	80	8.53	

CMFO-N0 • Single Segmented Open Bottom Non Powered Fabric Panel, No Punchouts

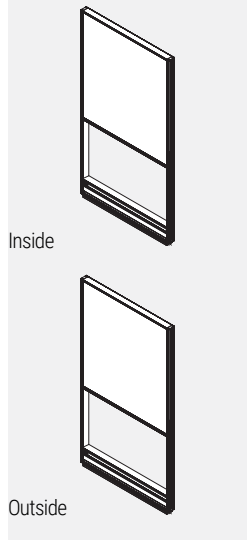

- Individual fabric-covered module in upper position incorporated into an aluminum frame.
- Bottom is open.
- Opposite sides of each module may have a different fabric within the same grade at no upcharge.
- If different grades of fabric are used on one panel, the entire panel must be priced at highest grade.
- Panels are not tackable.
- Note: Trim is not required at a straight connection between two panels of the same height.
- 3 Panel connector brackets per side come standard with 42”h. and 54”h. panels.
- 4 Panel connector brackets per side come standard with 66”h. panels.
- Panels include 2 raceway covers with no punchouts, an integrated aluminum top cap and levelling glides.
- PVC trim kit available in black only.

PRODUCT CODE	PRICE		SIZE/ INCHES			WEIGHT VOL	
	GR 1	GR 2	H	W	D	LBS	FT ³
CMFO4224N0	271	281	42	24	2.3	15	2.31
CMFO4230N0	339	349	42	30	2.3	17	2.85
CMFO4236N0	365	383	42	36	2.3	21	3.38
CMFO4242N0	418	438	42	42	2.3	24	3.92
CMFO4248N0	446	464	42	48	2.3	28	4.45
CMFO4254N0	486	513	42	54	2.3	31	4.99
CMFO4260N0	536	552	42	60	2.3	34	5.52
CMFO5424N0	319	336	54	24	2.3	20	2.73
CMFO5430N0	365	378	54	30	2.3	25	3.37
CMFO5436N0	415	431	54	36	2.3	29	4.00
CMFO5442N0	476	507	54	42	2.3	34	4.63
CMFO5448N0	508	539	54	48	2.3	38	5.26
CMFO5454N0	553	584	54	54	2.3	43	5.89
CMFO5460N0	589	619	54	60	2.3	48	6.53
CMFO6624N0	352	377	66	24	2.3	25	3.58
CMFO6630N0	394	418	66	30	2.3	31	4.40
CMFO6636N0	473	516	66	36	2.3	38	5.23
CMFO6642N0	536	578	66	42	2.3	44	6.06
CMFO6648N0	561	604	66	48	2.3	50	6.88
CMFO6654N0	612	656	66	54	2.3	56	7.71
CMFO6660N0	654	695	66	60	2.3	63	8.53

CMFO-N1 • Single Segmented Open Bottom Non Powered Fabric Panel, Punchouts on One Side

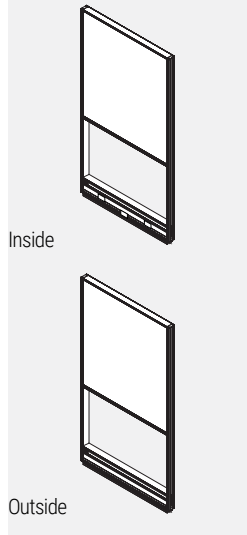

- Individual fabric-covered module in upper position incorporated into an aluminum frame.
- Bottom is open.
- Opposite sides of each module may have a different fabric within the same grade at no upcharge.
- If different grades of fabric are used on one panel, the entire panel must be priced at highest grade.
- Panels are not tackable.
- Note: Trim is not required at a straight connection between two panels of the same height.
- 3 Panel connector brackets per side come standard with 42”h. and 54”h. panels.
- 4 Panel connector brackets per side come standard with 66”h. panels.
- Panels include 1 raceway cover with punchouts on one side, 1 raceway cover with no punchouts on the other, an integrated aluminum top cap and levelling glides.
- 24” wide panels have two punchouts, one for electrical and one for data.
- 30” wide panels and wider have three punchouts, two for electrical and one for data.
- PVC trim kit available in black only.

PRODUCT CODE	PRICE		SIZE/ INCHES			WEIGHT VOL	
	GR 1	GR 2	H	W	D	LBS	FT ³
CMFO4224N1	271	281	42	24	2.3	15	2.31
CMFO4230N1	339	349	42	30	2.3	17	2.85
CMFO4236N1	365	383	42	36	2.3	21	3.38
CMFO4242N1	418	438	42	42	2.3	24	3.92
CMFO4248N1	446	464	42	48	2.3	28	4.45
CMFO4254N1	486	513	42	54	2.3	31	4.99
CMFO4260N1	536	552	42	60	2.3	34	5.52
CMFO5424N1	319	336	54	24	2.3	20	2.73
CMFO5430N1	365	378	54	30	2.3	25	3.37
CMFO5436N1	415	431	54	36	2.3	29	4.00
CMFO5442N1	476	507	54	42	2.3	34	4.63
CMFO5448N1	508	539	54	48	2.3	38	5.26
CMFO5454N1	553	584	54	54	2.3	43	5.89
CMFO5460N1	589	619	54	60	2.3	48	6.53
CMFO6624N1	352	377	66	24	2.3	25	3.58
CMFO6630N1	394	418	66	30	2.3	31	4.40
CMFO6636N1	473	516	66	36	2.3	38	5.23
CMFO6642N1	536	578	66	42	2.3	44	6.06
CMFO6648N1	561	604	66	48	2.3	50	6.88
CMFO6654N1	612	656	66	54	2.3	56	7.71
CMFO6660N1	654	695	66	60	2.3	63	8.53

CMFO-N2 • Single Segmented Open Bottom Non Powered Fabric Panel, Punchouts on Both Sides

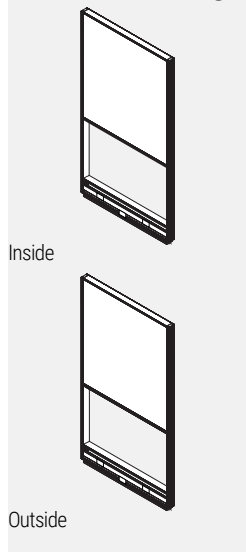

- Individual fabric-covered module in upper position incorporated into an aluminum frame.
- Bottom is open.
- Opposite sides of each module may have a different fabric within the same grade at no upcharge.
- If different grades of fabric are used on one panel, the entire panel must be priced at highest grade.
- Panels are not tackable.
- Note: Trim is not required at a straight connection between two panels of the same height.
- 3 Panel connector brackets per side come standard with 42”h. and 54”h. panels.
- 4 Panel connector brackets per side come standard with 66”h. panels.
- Panels include 2 raceway covers with punchouts on both sides, an integrated aluminum top cap and levelling glides.
- 24” wide panels have two punchouts, one for electrical and one for data.
- 30” wide panels and wider have three punchouts, two for electrical and one for data.
- PVC trim kit available in black only.

PRODUCT CODE	PRICE		SIZE/ INCHES			WEIGHT VOL	
	GR 1	GR 2	H	W	D	LBS	FT ³
CMFO4224N2	271	281	42	24	2.3	15	2.31
CMFO4230N2	339	349	42	30	2.3	17	2.85
CMFO4236N2	365	383	42	36	2.3	21	3.38
CMFO4242N2	418	438	42	42	2.3	24	3.92
CMFO4248N2	446	464	42	48	2.3	28	4.45
CMFO4254N2	486	513	42	54	2.3	31	4.99
CMFO4260N2	536	552	42	60	2.3	34	5.52
CMFO5424N2	319	336	54	24	2.3	20	2.73
CMFO5430N2	365	378	54	30	2.3	25	3.37
CMFO5436N2	415	431	54	36	2.3	29	4.00
CMFO5442N2	476	507	54	42	2.3	34	4.63
CMFO5448N2	508	539	54	48	2.3	38	5.26
CMFO5454N2	553	584	54	54	2.3	43	5.89
CMFO5460N2	589	619	54	60	2.3	48	6.53
CMFO6624N2	352	377	66	24	2.3	25	3.58
CMFO6630N2	394	418	66	30	2.3	31	4.40
CMFO6636N2	473	516	66	36	2.3	38	5.23
CMFO6642N2	536	578	66	42	2.3	44	6.06
CMFO6648N2	561	604	66	48	2.3	50	6.88
CMFO6654N2	612	656	66	54	2.3	56	7.71
CMFO6660N2	654	695	66	60	2.3	63	8.53

CMFO-P1 • Single Segmented Open Bottom Powered Fabric Panel, Punchouts on One Side

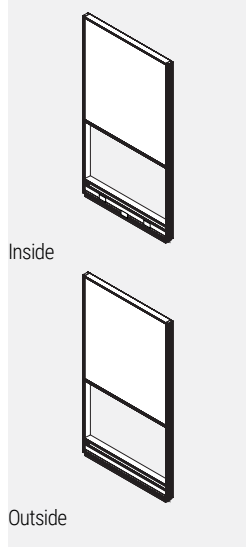

- Individual fabric-covered module in upper position incorporated into an aluminum frame.
- Bottom is open.
- Opposite sides of each module may have a different fabric within the same grade at no upcharge.
- If different grades of fabric are used on one panel, the entire panel must be priced at highest grade.
- Panels are not tackable.
- Note: Trim is not required at a straight connection between two panels of the same height.
- 3 Panel connector brackets per side come standard with 42”h. and 54”h. panels.
- 4 Panel connector brackets per side come standard with 66”h. panels.
- Panels include 1 raceway cover with punchouts on one side, 1 raceway cover with no punchouts on the other, a power distribution housing, an integrated aluminum top cap and levelling glides.
- 24” wide panels have two punchouts, one for electrical and one for data.
- 30” wide panels and wider have three punchouts, two for electrical and one for data.
- Please specify duplex receptacles separately.
- PVC trim kit available in black only.

PRODUCT CODE	PRICE		SIZE/ INCHES			WEIGHT VOL	
	GR 1	GR 2	H	W	D	LBS	FT ³
CMFO4224P1	401	411	42	24	2.3	15	2.31
CMFO4230P1	512	521	42	30	2.3	17	2.85
CMFO4236P1	546	567	42	36	2.3	21	3.38
CMFO4242P1	605	625	42	42	2.3	24	3.92
CMFO4248P1	644	661	42	48	2.3	28	4.45
CMFO4254P1	689	698	42	54	2.3	31	4.99
CMFO4260P1	737	757	42	60	2.3	34	5.52
CMFO5424P1	449	462	54	24	2.3	20	2.73
CMFO5430P1	540	552	54	30	2.3	25	3.37
CMFO5436P1	595	610	54	36	2.3	29	4.00
CMFO5442P1	661	693	54	42	2.3	34	4.63
CMFO5448P1	707	736	54	48	2.3	38	5.26
CMFO5454P1	757	786	54	54	2.3	43	5.89
CMFO5460P1	791	823	54	60	2.3	48	6.53
CMFO6624P1	482	507	66	24	2.3	25	3.58
CMFO6630P1	568	591	66	30	2.3	31	4.40
CMFO6636P1	654	695	66	36	2.3	38	5.23
CMFO6642P1	722	765	66	42	2.3	44	6.06
CMFO6648P1	758	802	66	48	2.3	50	6.88
CMFO6654P1	814	857	66	54	2.3	56	7.71
CMFO6660P1	856	898	66	60	2.3	63	8.53

CMFO-P2 • Single Segmented Open Bottom Powered Fabric Panel, Punchouts on Both Sides

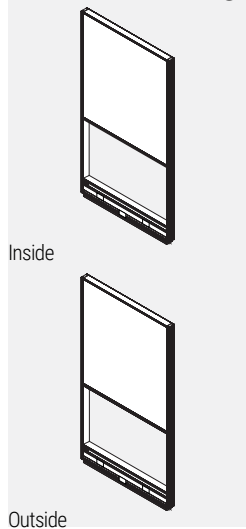

- Individual fabric-covered module in upper position incorporated into an aluminum frame.
- Bottom is open.
- Opposite sides of each module may have a different fabric within the same grade at no upcharge.
- If different grades of fabric are used on one panel, the entire panel must be priced at highest grade.
- Panels are not tackable.
- Note: Trim is not required at a straight connection between two panels of the same height.
- 3 Panel connector brackets per side come standard with 42”h. and 54”h. panels.
- 4 Panel connector brackets per side come standard with 66”h. panels.
- Panels include 2 raceway covers with punchouts on both sides, a power distribution housing, an integrated aluminum top cap and levelling glides.
- 24” wide panels have two punchouts, one for electrical and one for data.
- 30” wide panels and wider have three punchouts, two for electrical and one for data.
- Please specify duplex receptacles separately.
- PVC trim kit available in black only.

PRODUCT CODE	PRICE		SIZE/ INCHES			WEIGHT VOL	
	GR 1	GR 2	H	W	D	LBS	FT ³
CMFO4224P2	401	411	42	24	2.3	15	2.31
CMFO4230P2	512	521	42	30	2.3	17	2.85
CMFO4236P2	546	567	42	36	2.3	21	3.38
CMFO4242P2	605	625	42	42	2.3	24	3.92
CMFO4248P2	644	661	42	48	2.3	28	4.45
CMFO4254P2	689	698	42	54	2.3	31	4.99
CMFO4260P2	737	757	42	60	2.3	34	5.52
CMFO5424P2	449	462	54	24	2.3	20	2.73
CMFO5430P2	540	552	54	30	2.3	25	3.37
CMFO5436P2	595	610	54	36	2.3	29	4.00
CMFO5442P2	661	693	54	42	2.3	34	4.63
CMFO5448P2	707	736	54	48	2.3	38	5.26
CMFO5454P2	757	786	54	54	2.3	43	5.89
CMFO5460P2	791	823	54	60	2.3	48	6.53
CMFO6624P2	482	507	66	24	2.3	25	3.58
CMFO6630P2	568	591	66	30	2.3	31	4.40
CMFO6636P2	654	695	66	36	2.3	38	5.23
CMFO6642P2	722	765	66	42	2.3	44	6.06
CMFO6648P2	758	802	66	48	2.3	50	6.88
CMFO6654P2	814	857	66	54	2.3	56	7.71
CMFO6660P2	856	898	66	60	2.3	63	8.53

CMOF • Compile Fabric Over Panel

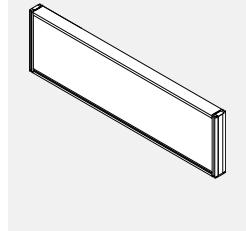

- Individual fabric-covered modules incorporated into an aluminum frame.
- Opposite sides of each module may have a different fabric within the same grade at no upcharge.
- If different grades of fabric are used on one panel, the entire panel must be priced at highest grade.
- Panels are not tackable.
- 2 Panel connector brackets per side are standard
- CHSD Compile Slider Kit for Over Panel required for installation and is included with each over panel.
- Note: Trim is not required at a straight connection between two panels of the same height.
- **Note: All over panels are non load bearing.**

PRODUCT CODE	PRICE		SIZE/ INCHES			WEIGHT VOL	
	GR 1	GR 2	H	W	D	LBS	FT ³
CMOF1224	134	156	12	24	2.3	8	0.38
CMOF1230	158	178	12	30	2.3	10	0.48
CMOF1236	174	196	12	36	2.3	12.4	0.58
CMOF1242	199	218	12	42	2.3	14.4	0.67
CMOF1248	231	249	12	48	2.3	16.4	0.7
CMOF1254	238	260	12	54	2.3	18.4	0.86
CMOF1260	283	304	12	60	2.3	20.4	0.96
CMOF1624	157	180	16	30	2.3	15	0.64
CMOF1630	182	208	16	36	2.3	18.6	0.77
CMOF1636	194	217	16	42	2.3	21.6	0.89
CMOF1642	233	255	16	48	2.3	24.6	1.02
CMOF1648	264	287	16	54	2.3	27.6	1.15
CMOF1654	276	302	16	60	2.3	30.6	1.28
CMOF1660	324	349	16	66	2.3	33.6	1.42
CMOF2424	202	240	24	24	2.3	16	0.77
CMOF2430	235	268	24	30	2.3	20	0.96
CMOF2436	263	298	24	36	2.3	24.8	1.15
CMOF2442	297	330	24	42	2.3	28.8	1.34
CMOF2448	317	351	24	48	2.3	32.8	1.53
CMOF2454	352	386	24	54	2.3	36.8	1.73
CMOF2460	406	439	24	60	2.3	40.8	1.92

CMOLF • Compile Laminate One Side, Fabric One Side Over Panel

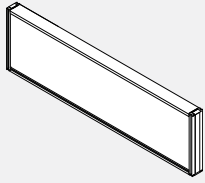

- Individual modules, one side in fabric and one side in laminate, incorporated into an aluminum frame.
- Panels are not tackable.
- 2 Panel connector brackets per side are standard
- CHSD Compile Slider Kit for Over Panel required for installation and is included with each over panel.
- Note: Trim is not required at a straight connection between two panels of the same height.
- **Note: All over panels are non load bearing.**

PRODUCT CODE	PRICE		SIZE/ INCHES			WEIGHT VOL	
	GR 1	GR 2	H	W	D	LBS	FT ³
CMOLF1224	151	161	12	24	2.3	8	0.38
CMOLF1230	178	187	12	30	2.3	10	0.48
CMOLF1236	201	211	12	36	2.3	12.4	0.58
CMOLF1242	229	238	12	42	2.3	14.4	0.67
CMOLF1248	264	274	12	48	2.3	16.4	0.7
CMOLF1254	276	285	12	54	2.3	18.4	0.86
CMOLF1260	327	336	12	60	2.3	20.4	0.96
CMOLF1624	179	193	16	30	2.3	15	0.64
CMOLF1630	215	229	16	36	2.3	18.6	0.77
CMOLF1636	238	249	16	42	2.3	21.6	0.89
CMOLF1642	271	283	16	48	2.3	24.6	1.02
CMOLF1648	309	320	16	54	2.3	27.6	1.15
CMOLF1654	328	340	16	60	2.3	30.6	1.28
CMOLF1660	380	392	16	66	2.3	33.6	1.41
CMOLF2424	237	252	24	24	2.3	16	0.77
CMOLF2430	283	301	24	30	2.3	20	0.96
CMOLF2436	313	330	24	36	2.3	24.8	1.15
CMOLF2442	353	371	24	42	2.3	28.8	1.34
CMOLF2448	385	404	24	48	2.3	32.8	1.53
CMOLF2454	430	444	24	54	2.3	36.8	1.73
CMOLF2460	488	507	24	60	2.3	40.8	1.92

CMOLL • Compile Laminate Two Sides Over Panel

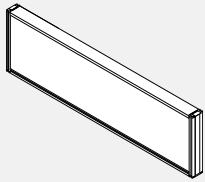

- Individual laminate modules incorporated into an aluminum frame.
- Panels are not tackable.
- 2 Panel connector brackets per side are standard
- CHSD Compile Slider Kit for Over Panel required for installation and is included with each over panel.
- Note: Trim is not required at a straight connection between two panels of the same height.
- **Note: All over panels are non load bearing.**

PRODUCT CODE	PRICE		SIZE/ INCHES			WEIGHT VOL	
	GR 1	GR 2	H	W	D	LBS	FT ³
CMOLL1224	168		12	24	2.3	8	0.38
CMOLL1230	192		12	30	2.3	10	0.48
CMOLL1236	225		12	36	2.3	12.4	0.58
CMOLL1242	255		12	42	2.3	14.4	0.67
CMOLL1248	295		12	48	2.3	16.4	0.7
CMOLL1254	312		12	54	2.3	18.4	0.86
CMOLL1260	365		12	60	2.3	20.4	0.96
CMOLL1624	200		16	24	2.3	12	0.51
CMOLL1630	237		16	30	2.3	15	0.64
CMOLL1636	270		16	36	2.3	18.6	0.77
CMOLL1642	306		16	42	2.3	21.6	0.89
CMOLL1648	350		16	48	2.3	24.6	1.02
CMOLL1654	373		16	54	2.3	27.6	1.15
CMOLL1660	433		16	60	2.3	30.6	1.28
CMOLL2424	268		24	24	2.3	16	0.77
CMOLL2430	316		24	30	2.3	20	0.96
CMOLL2436	361		24	36	2.3	24.8	1.15
CMOLL2442	408		24	42	2.3	28.8	1.34
CMOLL2448	448		24	48	2.3	32.8	1.53
CMOLL2454	499		24	54	2.3	36.8	1.73
CMOLL2460	568		24	60	2.3	40.8	1.92

CMOG • Compile Glazed Over Panel

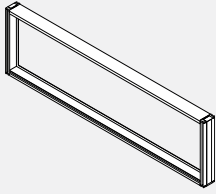

- Individual glazed module incorporated into an aluminum frame.
- Standard in clear (CLR) plexi.
- Optional frosted (FRST) plexi.
- Panels are not tackable.
- 2 Panel connector brackets per side are standard
- The PVC trim for glass can be different finish than the frame of the over panels, please specify two finishes.
- CHSD Compile Slider Kit for Over Panel required for installation and is included with each over panel.
- Note: Trim is not required at a straight connection between two panels of the same height.
- **Note: All over panels are non load bearing.**

PRODUCT CODE	PRICE	SIZE/ INCHES			WEIGHT VOL	
		H	W	D	LBS	FT ³
CMOG1224	122	12	24	2.3	8	0.38
CMOG1230	139	12	30	2.3	10	0.48
CMOG1236	156	12	36	2.3	12.4	0.58
CMOG1242	174	12	42	2.3	14.4	0.67
CMOG1248	201	12	48	2.3	16.4	0.7
CMOG1254	210	12	54	2.3	18.4	0.86
CMOG1260	248	12	60	2.3	20.4	0.96
CMOG1624	139	16	24	2.3	12	0.51
CMOG1630	161	16	30	2.3	15	0.64
CMOG1636	179	16	36	2.3	18.6	0.77
CMOG1642	202	16	42	2.3	21.6	0.89
CMOG1648	233	16	48	2.3	24.6	1.02
CMOG1654	239	16	54	2.3	27.6	1.15
CMOG1660	283	16	60	2.3	30.6	1.28
CMOG2424	178	24	24	2.3	16	0.77
CMOG2430	194	24	30	2.3	20	0.96
CMOG2436	227	24	36	2.3	24.8	1.15
CMOG2442	253	24	42	2.3	28.8	1.34
CMOG2448	273	24	48	2.3	32.8	1.53
CMOG2454	303	24	54	2.3	36.8	1.73
CMOG2460	350	24	60	2.3	40.8	1.92

CMOFW • Compile One Side Write Board Over Panel

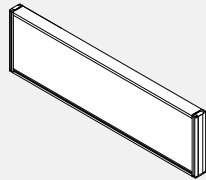

- Individual fabric or write board covered modules incorporated into an aluminum frame.
- Modules have write board on one side and fabric on the other.
- Panels are not tackable.
- 2 Panel connector brackets per side are standard
- CHSD Compile Slider Kit for Over Panel required for installation and is included with each over panel.
- Note: Trim is not required at a straight connection between two panels of the same height.
- **Note: All over panels are non load bearing.**

PRODUCT CODE	PRICE		SIZE/ INCHES			WEIGHT VOL	
	GR 1	GR 2	H	W	D	LBS	FT ³
CMOFW1224	170	179	12	24	2.3	8	0.38
CMOFW1230	201	211	12	30	2.3	10	0.48
CMOFW1236	229	238	12	36	2.3	12.4	0.58
CMOFW1242	262	271	12	42	2.3	14.4	0.67
CMOFW1248	287	299	12	48	2.3	16.4	0.7
CMOFW1254	318	329	12	54	2.3	18.4	0.86
CMOFW1260	371	380	12	60	2.3	20.4	0.96
CMOFW1624	204	215	16	24	2.3	12	0.51
CMOFW1630	241	253	16	30	2.3	15	0.64
CMOFW1636	276	287	16	36	2.3	18.6	0.77
CMOFW1642	313	327	16	42	2.3	21.6	0.89
CMOFW1648	357	371	16	48	2.3	24.6	1.02
CMOFW1654	383	396	16	54	2.3	27.6	1.15
CMOFW1660	442	454	16	60	2.3	30.6	1.28
CMOFW2424	265	281	24	24	2.3	16	0.77
CMOFW2430	305	320	24	30	2.3	20	0.96
CMOFW2436	373	389	24	36	2.3	24.8	1.15
CMOFW2442	418	435	24	42	2.3	28.8	1.34
CMOFW2448	441	456	24	48	2.3	32.8	1.53
CMOFW2454	525	543	24	54	2.3	36.8	1.73
CMOFW2460	584	602	24	60	2.3	40.8	1.92

CMOWW• Compile Write Board Two Sides Over Panel

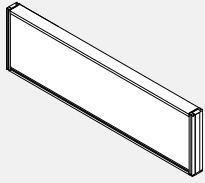

- Individual write board covered modules incorporated into an aluminum frame.
- Modules have write board on both sides.
- Panels are not tackable.
- 2 Panel connector brackets per side are standard
- CHSD Compile Slider Kit for Over Panel required for installation and is included with each over panel.
- Note: Trim is not required at a straight connection between two panels of the same height.
- **Note: All over panels are non load bearing.**

PRODUCT CODE	PRICE	SIZE/ INCHES			WEIGHT VOL	
		H	W	D	LBS	FT ³
CMOWW1224	207	12	24	2.3	8	0.38
CMOWW1230	239	12	30	2.3	10	0.48
CMOWW1236	284	12	36	2.3	12.4	0.58
CMOWW1242	318	12	42	2.3	14.4	0.67
CMOWW1248	373	12	48	2.3	16.4	0.7
CMOWW1254	394	12	54	2.3	18.4	0.86
CMOWW1260	455	12	60	2.3	20.4	0.96
CMOWW1624	252	16	24	2.3	12	0.51
CMOWW1630	304	16	30	2.3	15	0.64
CMOWW1636	349	16	36	2.3	18.6	0.77
CMOWW1642	399	16	42	2.3	21.6	0.89
CMOWW1648	456	16	48	2.3	24.6	1.02
CMOWW1654	494	16	54	2.3	27.6	1.15
CMOWW1660	565	16	60	2.3	30.6	1.28
CMOWW2424	347	24	24	2.3	16	0.77
CMOWW2430	416	24	30	2.3	20	0.96
CMOWW2436	480	24	36	2.3	24.8	1.15
CMOWW2442	548	24	42	2.3	28.8	1.34
CMOWW2448	608	24	48	2.3	32.8	1.53
CMOWW2454	679	24	54	2.3	36.8	1.73
CMOWW2460	766	24	60	2.3	40.8	1.92

BPDSL • Sliding Door

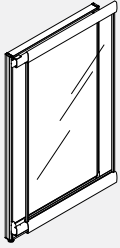

- Provides territorial privacy in an open plan environment.
- Lightweight, panel mounted sliding partition.
- Consists of translucent polycarbonate.
- Must be mounted to a straight panel of the same size.
- The face of the Privacy Screen sits 3" away from the face of the panel to which it is attached.
- When open, the screen may interfere with access doors that open on the outside of an adjacent panel.
- Caps located on the end of the frame default to the panel frame colour.
- Four sliders included for each door.
- Can be mounted on panels of the same width.
- Note: Specify left or right for the direction in which the door will slide as per examples above.

PRODUCT CODE	PRICE	SIZE/ INCHES			WEIGHT VOL	
		H	W	D	LBS	FT ³
BPDSL6636R	1981	66	36	2.61	35	5.98
BPDSL6642R	2132	66	42	2.61	42	6.93
BPDSL6636L	1981	66	36	2.61	35	5.98
BPDSL6642L	2132	66	42	2.61	42	6.93

Left Hang Option

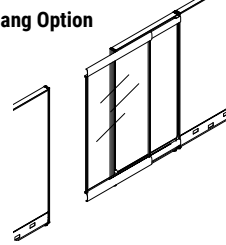

Right Hang Hung

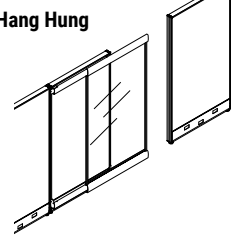

CMPS • Privacy Glass

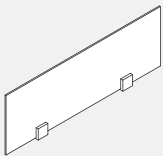

- Privacy Glass with no frame sits on top of a Panel with clamps that are secured to the top of the panel to provide division.
- Tempered glass is 12", 9" or 6" high (nominal).
- Custom sizes available, contact your Customer Service Representative.
- Square clamps included.

PRODUCT CODE	PRICE		SIZE/ INCHES			WEIGHT VOL	
	CLR	FRST	H	W	D	LBS	FT ³
12"							
CMPS24	200	227	12	24	1.3	8	0.44
CMPS30	219	249	12	30	1.3	10	0.59
CMPS36	235	271	12	36	1.3	12	0.73
CMPS42	249	293	12	42	1.3	14	0.88
CMPS48	259	306	12	48	1.3	16	0.96
CMPS54	259	306	12	54	1.3	18	1.13
CMPS60	299	339	12	60	1.3	20	1.28
9"							
CMPS0924	200	227	9	24	1.3	8	0.44
CMPS0930	219	249	9	30	1.3	10	0.59
CMPS0936	235	271	9	36	1.3	12	0.73
CMPS0942	249	293	9	42	1.3	14	0.88
CMPS0948	259	306	9	48	1.3	18	0.98
CMPS0954	259	306	9	54	1.3	18	1.13
CMPS0960	299	339	9	60	1.3	20	1.28
6"							
CMPS0624	200	227	6	24	1.3	8	0.44
CMPS0630	219	249	6	30	1.3	10	0.59
CMPS0636	235	271	6	36	1.3	12	0.73
CMPS0642	249	293	6	42	1.3	14	0.88
CMPS0648	259	306	6	48	1.3	18	0.98
CMPS0654	259	306	6	54	1.3	18	1.13
CMPS0660	299	339	6	60	1.3	20	1.28

CMPSG • Integrated Privacy Glass Divider

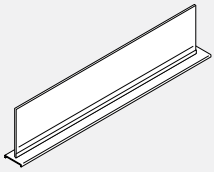

- Privacy Glass integrated with aluminum top trim.
- Attaches on top of panels to add privacy or divide space Includes aluminum trim with channel and glass tile.
- Standard in clear (CLR) or frosted (FRST) glass.
- Glass and attachment hardware to ship seperately.

PRODUCT CODE	PRICE		SIZE/INCHES			WEIGHT VOL	
	CLR	FRST	H	W	D	LBS	FT ³
CMPSG0624	182	229	6.40	22.67	2.41	3.54	0.20
CMPSG0630	200	251	6.40	28.67	2.41	4.49	0.26
CMPSG0636	212	265	6.40	34.67	2.41	5.44	0.31
CMPSG0642	229	284	6.40	40.67	2.41	6.39	0.36
CMPSG0648	238	297	6.40	46.67	2.41	7.34	0.42
CMPSG0654	245	306	6.40	52.67	2.41	8.29	0.47
CMPSG0660	251	312	6.40	58.67	2.41	9.23	0.52
CMPSG0924	182	229	9.40	22.67	2.41	4.99	0.30
CMPSG0930	200	251	9.40	28.67	2.41	6.32	0.38
CMPSG0936	212	265	9.40	34.67	2.41	7.66	0.46
CMPSG0942	229	284	9.40	40.67	2.41	8.99	0.53
CMPSG0948	238	297	9.40	46.67	2.41	10.33	0.61
CMPSG0954	245	306	9.40	52.67	2.41	11.66	0.69
CMPSG0960	251	312	9.40	58.67	2.41	13.00	0.77
CMPSG1224	182	229	12.40	22.67	2.41	6.43	0.39
CMPSG1230	200	251	12.40	28.67	2.41	8.15	0.50
CMPSG1236	212	265	12.40	34.67	2.41	9.87	0.60
CMPSG1242	229	284	12.40	40.67	2.41	11.59	0.70
CMPSG1248	238	297	12.40	46.67	2.41	13.31	0.81
CMPSG1254	245	306	12.40	52.67	2.41	15.04	0.91
CMPSG1260	251	312	12.40	58.67	2.41	16.76	1.02

CMPEEG • Integrated Privacy Glass Extended Divider

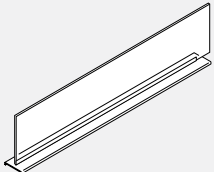

- Privacy Glass integrated with aluminum top trim.
- Glass is longer to extend partially over the post for a corner application.
- Attaches on top of panels to add privacy or divide space Includes aluminum trim with channel and glass tile.
- Standard in clear (CLR) or frosted (FRST) glass.
- Glass and attachment hardware to ship seperately.

PRODUCT CODE	PRICE		SIZE/INCHES			WEIGHT VOL	
	CLR	FRST	H	W	D	LBS	FT ³
CMPEEG0624	182	229	6.4	23.88	2.41	3.54	0.21
CMPEEG0630	200	251	6.4	29.88	2.41	4.49	0.27
CMPEEG0636	212	265	6.4	35.88	2.41	5.44	0.32
CMPEEG0642	229	284	6.4	41.88	2.41	6.39	0.37
CMPEEG0648	238	297	6.4	47.88	2.41	7.34	0.43
CMPEEG0654	245	306	6.4	53.88	2.41	8.29	0.48
CMPEEG0660	251	312	6.4	59.88	2.41	9.23	0.54
CMPEEG0924	182	229	9.4	23.88	2.41	4.99	0.31
CMPEEG0930	200	251	9.4	29.88	2.41	6.32	0.39
CMPEEG0936	212	265	9.4	35.88	2.41	7.66	0.47
CMPEEG0942	229	284	9.4	41.88	2.41	8.99	0.55
CMPEEG0948	238	297	9.4	47.88	2.41	10.33	0.63
CMPEEG0954	245	306	9.4	53.88	2.41	11.66	0.71
CMPEEG0960	251	312	9.4	59.88	2.41	13	0.79
CMPEEG1224	182	229	12.4	23.88	2.41	6.43	0.41
CMPEEG1230	200	251	12.4	29.88	2.41	8.15	0.52
CMPEEG1236	212	265	12.4	35.88	2.41	9.87	0.62
CMPEEG1242	229	284	12.4	41.88	2.41	11.59	0.73
CMPEEG1248	238	297	12.4	47.88	2.41	13.31	0.83
CMPEEG1254	245	306	12.4	53.88	2.41	15.04	0.93
CMPEEG1260	251	312	12.4	59.88	2.41	16.76	1.04

CMPSF • Integrated Felt Divider

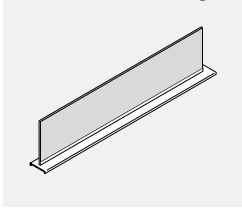

- Privacy felt panel intergrated with aluminum top trim.
- Attaches on top of panels to add privacy or divide space. Includes aluminum trim with channel and felt tile.
- Felt and attachment hardware to ship seperaretyly.
- 9mm Felt material is tackable and comes in 18 different colours. Please specify colour.

PRODUCT CODE	PRICE	SIZE/INCHES			WEIGHT VOL	
		H	W	D	LBS	FT³
CMPSF0624	66	6.33	22.42	2.41	1.21	0.20
CMPSF0630	78	6.33	28.42	2.41	1.54	0.25
CMPSF0636	92	6.33	34.42	2.41	1.86	0.30
CMPSF0642	103	6.33	40.42	2.41	2.19	0.36
CMPSF0648	156	6.33	46.42	2.41	2.51	0.41
CMPSF0654	169	6.33	52.42	2.41	2.84	0.46
CMPSF0660	180	6.33	58.42	2.41	3.16	0.52
CMPSF0924	66	9.33	22.42	2.41	1.48	0.29
CMPSF0930	78	9.33	28.42	2.41	1.87	0.37
CMPSF0936	92	9.33	34.42	2.41	2.27	0.45
CMPSF0942	103	9.33	40.42	2.41	2.66	0.53
CMPSF0948	156	9.33	46.42	2.41	3.06	0.60
CMPSF0954	169	9.33	52.42	2.41	3.45	0.68
CMPSF0960	180	9.33	58.42	2.41	3.85	0.76
CMPSF1224	66	12.33	22.42	2.41	1.74	0.39
CMPSF1230	78	12.33	28.42	2.41	2.20	0.49
CMPSF1236	92	12.33	34.42	2.41	2.67	0.59
CMPSF1242	103	12.33	40.42	2.41	3.14	0.70
CMPSF1248	156	12.33	46.42	2.41	3.60	0.80
CMPSF1254	169	12.33	52.42	2.41	4.07	0.90
CMPSF1260	180	12.33	58.42	2.41	4.53	1.01

CMPEF • Integrated Felt Extended Divider

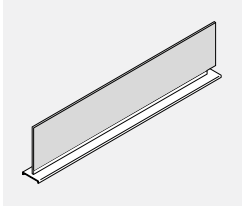

- Privacy felt panel intergrated with aluminum top trim.
- Felt is longer to extend partially over the post for a corner application.
- Attaches on top of panels to add privacy or divide space. Includes aluminum trim with channel and felt tile.
- Felt and attachment hardware to ship seperaretyly.
- 9mm Felt material is tackable and comes in 18 different colours. Please specify colour.

PRODUCT CODE	PRICE	SIZE/INCHES			WEIGHT VOL	
		H	W	D	LBS	FT³
CMPEF0624	66	6.33	23.88	2.41	1.21	0.21
CMPEF0630	78	6.33	29.88	2.41	1.54	0.36
CMPEF0636	92	6.33	35.88	2.41	1.86	0.32
CMPEF0642	103	6.33	41.88	2.41	2.19	0.37
CMPEF0648	156	6.33	47.88	2.41	2.51	0.42
CMPEF0654	169	6.33	53.88	2.41	2.84	0.48
CMPEF0660	180	6.33	59.88	2.41	3.16	0.53
CMPEF0924	66	9.33	23.88	2.41	1.48	0.31
CMPEF0930	78	9.33	29.88	2.41	1.87	0.39
CMPEF0936	92	9.33	35.88	2.41	2.27	0.47
CMPEF0942	103	9.33	41.88	2.41	2.66	0.55
CMPEF0948	156	9.33	47.88	2.41	3.06	0.62
CMPEF0954	169	9.33	53.88	2.41	3.45	0.7
CMPEF0960	180	9.33	59.88	2.41	3.85	0.78
CMPEF1224	66	12.33	23.88	2.41	1.74	0.41
CMPEF1230	78	12.33	29.88	2.41	2.2	0.51
CMPEF1236	92	12.33	35.88	2.41	2.67	0.62
CMPEF1242	103	12.33	41.88	2.41	3.14	0.72
CMPEF1248	156	12.33	47.88	2.41	3.6	0.82
CMPEF1254	169	12.33	53.88	2.41	4.07	0.93
CMPEF1260	180	12.33	59.88	2.41	4.53	1.03

CMLEP-NC • End of Run Gallery Panel With No End Connection

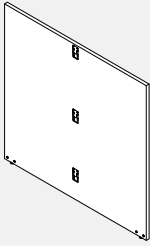

- Provides floor standing support while enclosing the end of a panel run.
- Attached at the end of a straight panel run with connectors to form a T configuration.
- No connections at both ends, connection is at the center interior face.
- Includes all attachment hardware and glides.
- Total height is inclusive of panel glides extended to their full height.
- 51" wide gallery panel accommodates two 24" deep surface while the 63" wide accommodates two 30" deep surfaces.
- Please specify LP laminate finish and PVC edge finish.
- If a wood grain laminate is chosen, grain direction run horizontally.
- Gallery panel is edged in PVC on exposed edges and self edged on bottom.

PRODUCT CODE	PRICE LP	SIZE /INCHES			WEIGHT LBS	VOL FT³
		H	W	D		
CMLEP4227NC	299	42	26.25	1	28.70	0.64
CMLEP4251NC	523	42	50.30	1	57.25	3.67
CMLEP4263NC	607	42	62.30	1	70.75	4.54
CMLEP4827NC	329	48	26.25	1	32.80	0.73
CMLEP4851NC	575	48	50.30	1	65.50	4.19
CMLEP4863NC	667	48	62.30	1	80.95	5.19
CMLEP5427NC	358	54	26.25	1	36.90	0.82
CMLEP5451NC	626	54	50.30	1	73.65	4.72
CMLEP5463NC	727	54	62.30	1	91.05	5.84

CMLMP-NC • Middle of Run Gallery Panel With No End Connection

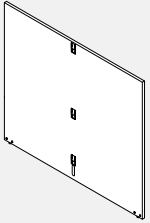

- Provides floor standing support in the middle of a panel run.
- Attached in the middle of a straight panel run with connectors to form an X configuration..
- No connections at both ends, connection is at center on both faces.
- Includes all attachment hardware and glides.
- Total height is inclusive of panel glides extended to their full height.
- 51" wide gallery panel accommodates two 24" deep surface while the 63" wide accommodates two 30" deep surfaces.
- Please specify LP laminate finish and PVC edge finish.
- If a wood grain laminate is chosen, grain direction run horizontally.
- Gallery panel is edged in PVC on exposed edges and self edged on bottom.

PRODUCT CODE	PRICE LP	SIZE /INCHES			WEIGHT LBS	VOL FT³
		H	W	D		
CMLMP4251NC	608	42	50.30	1	57.25	3.67
CMLMP4263NC	692	42	62.30	1	70.75	4.54
CMLMP4851NC	658	48	50.30	1	65.50	4.19
CMLMP4863NC	752	48	62.30	1	80.95	5.19
CMLMP5451NC	711	54	50.30	1	73.65	4.72
CMLMP5463NC	814	54	62.30	1	91.05	5.84

CMLSEPL-NC • Single End Of Run Gallery Panel With No End Connection



- Provides floor standing support while enclosing the end of a panel run.
- Attached at the end of a straight panel run with connectors to form an L configuration.
- No connection at ends, connection is on interior face at one end.
- Includes all attachment hardware and glides.
- Total height is inclusive of panel glides extended to their full height.
- 27" wide gallery panel accommodates a 24" deep surface while the 33" wide accommodates a 30" deep surface.
- Please specify LP laminate finish and PVC edge finish.
- If a wood grain laminate is chosen, grain direction run horizontally.
- Gallery panel is edged in PVC on exposed edges and self edged on bottom.

PRODUCT CODE	PRICE LP	SIZE /INCHES			WEIGHT LBS	VOL FT³
		H	W	D		
CMLSEPL4215NC	225	42	14.25	1	15.72	0.35
CMLSEPR4215NC	225	48	14.25	1	15.72	0.40
CMLSEPL4815NC	244	48	14.25	1	17.95	0.40
CMLSEPR4815NC	244	48	14.25	1	17.95	0.40
CMLSEPL5415NC	263	54	14.25	1	20.18	0.45
CMLSEPR5415NC	263	54	14.25	1	20.18	0.45
CMLSEPL4227NC	397	42	26.30	1	29.99	1.9
CMLSEPR4227NC	397	42	26.30	1	29.99	1.9
CMLSEPL4827NC	434	48	26.30	1	34.28	2.2
CMLSEPR4827NC	434	48	26.30	1	34.28	2.2
CMLSEPL5427NC	473	54	26.30	1	38.56	2.5
CMLSEPR5427NC	473	54	26.30	1	38.56	2.5
CMLSEPL4233NC	410	42	32.33	1	36.77	2.4
CMLSEPR4233NC	410	42	32.33	1	36.77	2.4
CMLSEPL4833NC	448	48	32.33	1	42.03	2.7
CMLSEPR4833NC	448	48	32.33	1	42.03	2.7
CMLSEPL5433NC	485	54	32.33	1	47.3	3.0
CMLSEPR5433NC	485	54	32.33	1	47.3	3.0

CMLSMP-NC • Single Middle of Run Gallery Panel With No End Connection

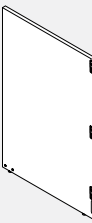

- Provides floor standing support at the middle of a panel run.
- Attached in the middle of a straight panel run with connectors to form a T configuration.
- No connections at the exposed end, connection is at both the interior and exterior face near the opposite end.
- Includes all attachment hardware and glides.
- Total height is inclusive of panel glides extended to their full height.
- 27" wide gallery panel accommodates a 24" deep surface while the 33" wide accommodates a 30" deep surface.
- Please specify LP laminate finish and PVC edge finish.
- If a wood grain laminate is chosen, grain direction run horizontally.
- Gallery panel is edged in PVC on exposed edges and self edged on bottom.

PRODUCT CODE	PRICE LP	SIZE /INCHES			WEIGHT LBS	VOL FT³
		H	W	D		
CMLSMP4227NC	483	42	26.30	1	30.14	1.92
CMLSMP4827NC	520	48	26.30	1	34.42	2.19
CMLSMP5427NC	556	54	26.30	1	38.72	2.47
CMLSMP4233NC	497	42	32.30	1	36.92	2.36
CMLSMP4833NC	536	48	32.30	1	42.18	2.69
CMLSMP5433NC	574	54	32.30	1	47.45	3.03

CMLEP • End Of Run Gallery Panel With End Connections

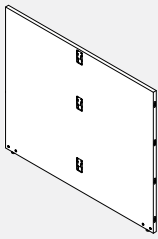

- Provides floor standing support while enclosing the end of a panel run.
- Attached at the end of a straight panel run with connectors to form a T configuration.
- Connections at both ends as well as the center on the interior face.
- Includes all attachment hardware and glides.
- Total height is inclusive of panel glides extended to their full height.
- 51" wide gallery panel accommodates two 24" deep surface while the 63" wide accommodates two 30" deep surfaces.
- Please specify LP laminate finish and PVC edge finish.
- If a wood grain laminate is chosen, grain direction run horizontally.
- Gallery panel is edged in PVC on exposed edges and self edged on edge connecting to panel and bottom edge.

PRODUCT CODE	PRICE LP	SIZE/INCHES			WEIGHT VOL	
		H	W	D	LBS	FT ³
CMLEP4251	543	42	50.30	1	57.25	3.67
CMLEP4263	626	42	62.30	1	70.75	4.54
CMLEP4851	593	48	50.30	1	65.50	4.19
CMLEP4863	688	48	62.30	1	80.95	5.19
CMLEP5451	646	54	50.30	1	73.65	4.72
CMLEP5463	748	54	62.30	1	91.05	5.84

CMLMP • Middle of Run Gallery Panel With End Connections

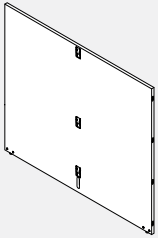

- Provides floor standing support in the middle of a panel run.
- Attached in the middle of a straight panel run with connectors to form an X configuration.
- Connections at both ends as well as the center on the interior and exterior face.
- Includes all attachment hardware and glides.
- Total height is inclusive of panel glides extended to their full height.
- 51" wide gallery panel accommodates two 24" deep surface while the 63" wide accommodates two 30" deep surfaces.
- Please specify LP laminate finish and PVC edge finish.
- If a wood grain laminate is chosen, grain direction run horizontally.
- Gallery panel is edged in PVC on exposed edges and self edged on edge connecting to panel and bottom edge.

PRODUCT CODE	PRICE LP	SIZE/INCHES			WEIGHT VOL	
		H	W	D	LBS	FT ³
CMLMP4251	612	42	50.30	1	57.25	3.67
CMLMP4263	695	42	62.30	1	70.75	4.54
CMLMP4851	665	48	50.30	1	65.50	4.19
CMLMP4863	757	48	62.30	1	80.95	5.19
CMLMP5451	715	54	50.30	1	73.65	4.72
CMLMP5463	818	54	62.30	1	91.05	5.84

CMLSEPL • Single End Panel With End Connections

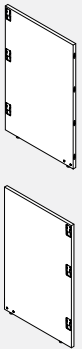

- Provides floor standing support while enclosing the end of a panel run.
- Attached at the end of a straight panel run with connectors to form an L configuration.
- Connections are at the exposed end on one side and near the end on the other interior face.
- Total height is inclusive of panel glides extended to their full height.
- 27" wide gallery panel accommodates a 24" deep surface while the 33" wide accommodates a 30" deep surface.
- Please specify LP laminate finish and PVC edge finish.
- If a wood grain laminate is chosen, grain direction run horizontally.
- Gallery panel is edged in PVC on exposed edges and self edged on edge connecting to panel and bottom edge.

PRODUCT CODE	PRICE LP	SIZE/INCHES			WEIGHT VOL	
		H	W	D	LBS	FT ³
CMLSEPL4227	408	42	26.30	1	29.99	1.9
CMLSEPR4227	408	42	26.30	1	29.99	1.9
CMLSEPL4827	444	48	26.30	1	34.28	2.2
CMLSEPR4827	444	48	26.30	1	34.28	2.2
CMLSEPL5427	482	54	26.30	1	38.56	2.5
CMLSEPR5427	482	54	26.30	1	38.56	2.5
CMLSEPL4233	419	42	32.33	1	36.77	2.4
CMLSEPR4233	419	42	32.33	1	36.77	2.4
CMLSEPL4833	457	48	32.33	1	42.03	2.7
CMLSEPR4833	457	48	32.33	1	42.03	2.7
CMLSEPL5433	496	54	32.33	1	47.3	3.0
CMLSEPR5433	496	54	32.33	1	47.3	3.0

CMLSMP • Single Middle of Run Gallery Panel With End Connections

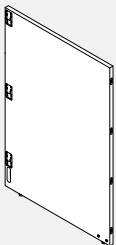

- Provides floor standing support at the middle of a panel run.
- Attached in the middle of a straight panel run with connectors to form a T configuration
- Connections are at the exposed end and at the interior and exterior near the opposite end, allows for left connection of CML2PL only.
- Includes all attachment hardware and glides.
- Total height is inclusive of panel glides extended to their full height.
- 27" wide gallery panel accommodates a 24" deep surface while the 33" wide accommodates a 30" deep surface.
- Please specify LP laminate finish and PVC edge finish.
- If a wood grain laminate is chosen, grain direction run horizontally.
- Gallery panel is edged in PVC on exposed edges and self edged on edge connecting to panel and bottom edge.

PRODUCT CODE	PRICE LP	SIZE/INCHES			WEIGHT VOL	
		H	W	D	LBS	FT ³
CMLSMP4227	494	42	26.30	1.00	30.14	1.92
CMLSMP4827	529	48	26.30	1.00	34.42	2.19
CMLSMP5427	567	54	26.30	1.00	38.72	2.47
CMLSMP4233	508	42	32.30	1.00	36.92	2.36
CMLSMP4833	546	48	32.30	1.00	42.18	2.69
CMLSMP5433	584	54	32.30	1.00	47.45	3.03

CML2PL • Left Two Way Return End of Run Gallery Panel With End Connections

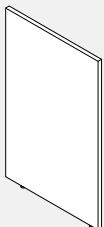

- Provides floor standing support while enclosing the end of a panel run.
- Attached at the end of a gallery panel with connectors to form an L configuration.
- Connections are at one exposed end.
- Includes all attachment hardware and glides.
- Total height is inclusive of panel glides extended to their full height.
- 25" wide gallery panel accommodates a 24" deep surface while the 31" wide accommodates a 30" deep surface.
- Please specify LP laminate finish and PVC edge finish.
- If a wood grain laminate is chosen, grain direction run horizontally.
- Gallery panel is edged in PVC on exposed edges and self edged on edge connecting to panel and bottom edge.

PRODUCT CODE	PRICE LP	SIZE/INCHES			WEIGHT VOL	
		H	W	D	LBS	FT ³
CML2PL4213	153	42	13	1	14.16	0.32
CML2PL4225	323	42	25	1	27.14	1.82
CML2PL4231	331	42	31	1	33.62	2.26
CML2PL4813	172	48	13	1	16.19	0.36
CML2PL4825	359	48	25	1	31.04	2.08
CML2PL4831	370	48	31	1	38.47	2.58
CML2PL5413	192	54	13	1	18.22	0.41
CML2PL5425	396	54	25	1	34.95	2.34
CML2PL5431	408	54	31	1	43.31	2.91

CML2PR • Right Two Way Return End of Run Gallery Panel With End Connections



- Provides floor standing support while enclosing the end of a panel run.
- Attached at the end of a gallery panel with connectors to form an L configuration.
- Connections are at one exposed end.
- Includes all attachment hardware and glides.
- Total height is inclusive of panel glides extended to their full height.
- 25" wide gallery panel accommodates a 24" deep surface while the 31" wide accommodates a 30" deep surface.
- Please specify LP laminate finish and PVC edge finish.
- If a wood grain laminate is chosen, grain direction run horizontally.
- Gallery panel is edged in PVC on exposed edges and self edged on edge connecting to panel and bottom edge.

PRODUCT CODE	PRICE LP	SIZE/INCHES			WEIGHT VOL	
		H	W	D	LBS	FT ³
CML2PR4213	153	42	13	1	14.16	0.32
CML2PR4225	323	42	25	1	27.14	1.82
CML2PR4231	331	42	31	1	33.62	2.26
CML2PR4813	172	48	13	1	16.19	0.36
CML2PR4825	359	48	25	1	31.04	2.08
CML2PR4831	370	48	31	1	38.47	2.58
CML2PR5413	192	54	13	1	18.22	0.41
CML2PR5425	396	54	25	1	34.95	2.34
CML2PR5431	408	54	31	1	43.31	2.91

CML3PL • Left Three Way Return End of Run Gallery Panel

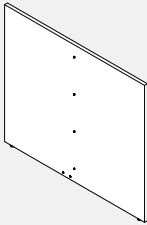

- Provides floor standing support while enclosing the end of a gallery panel run.
- Attached at the end of a gallery panel with connectors to form a T configuration.
- There are no connections at the exposed ends. Connection is at the center of the interior face.
- Connects to CMLXPL or CMLSEPL.
- Includes all attachment hardware and glides.
- Total height is inclusive of panel glides extended to their full height.
- 49" wide gallery panel accommodates two 24" deep surface while the 61" wide accommodates two 30" deep surfaces.
- Please specify LP laminate finish and PVC edge finish.
- If a wood grain laminate is chosen, grain direction run horizontally.
- Gallery panel is edged in PVC on exposed edges and self edged on edge connecting to panel and bottom edge.

PRODUCT CODE	PRICE LP	SIZE/INCHES			WEIGHT VOL	
		H	W	D	LBS	FT ³
CML3PL4225	229	42	25	1.3	27.14	0.79
CML3PL4249	448	42	49	1	53.09	3.57
CML3PL4261	529	42	61	1	66.06	4.45
CML3PL4825	256	48	25	1.3	31.04	0.90
CML3PL4849	499	48	49	1	60.74	4.08
CML3PL4861	591	48	61	1	75.60	5.08
CML3PL5425	286	54	25	1.3	34.95	1.02
CML3PL5449	550	54	49	1	68.40	4.59
CML3PL5461	653	54	61	1	85.13	5.72

CML3PR • Right Three Way Return End of Run Gallery Panel

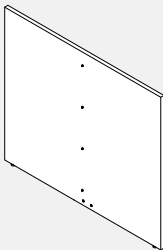

- Provides floor standing support while enclosing the end of a gallery panel run.
- Attached at the end of a gallery panel with connectors to form a T configuration.
- There are no connections at the exposed ends. Connection is at the center of the interior face.
- Connects to CMLXPR or CMLSEPR.
- Includes all attachment hardware and glides.
- Total height is inclusive of panel glides extended to their full height.
- 49" wide gallery panel accommodates two 24" deep surface while the 61" wide accommodates two 30" deep surfaces.
- Please specify LP laminate finish and PVC edge finish.
- If a wood grain laminate is chosen, grain direction run horizontally.
- Gallery panel is edged in PVC on exposed edges and self edged on edge connecting to panel and bottom edge.

PRODUCT CODE	PRICE LP	SIZE/INCHES			WEIGHT VOL	
		H	W	D	LBS	FT ³
CML3PR4225	229	42	25	1.3	27.14	0.79
CML3PR4249	448	42	49	1	53.09	3.57
CML3PR4261	529	42	61	1	66.06	4.45
CML3PR4825	256	48	25	1.3	31.04	0.90
CML3PR4849	499	48	49	1	60.74	4.08
CML3PR4861	591	48	61	1	75.60	5.08
CML3PR5425	286	54	25	1.3	34.95	1.02
CML3PR5449	550	54	49	1	68.40	4.59
CML3PR5461	653	54	61	1	85.13	5.72

CMLXPL • Left Extension End of Run Return Gallery Panel With End Connection

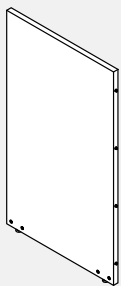

- Provides floor standing support while enclosing the end of a gallery panel run.
- Attached at the end of a panel to allow for extending the gallery panel run.
- Connections at both exposed ends, one to connect to the panel and one to connect to another gallery panel.
- Includes all attachment hardware and glides.
- Total height is inclusive of panel glides extended to their full height.
- Please specify LP laminate finish and PVC edge finish.
- If a wood grain laminate is chosen, grain direction run horizontally.
- Gallery panel is edged in PVC on exposed edges and self edges on edge connecting to panel.

PRODUCT CODE	PRICE LP	SIZE/INCHES			WEIGHT VOL	
		H	W	D	LBS	FT ³
CMLXPL4212	142	42	12.3	1	13.08	0.30
CMLXPL4224	268	42	24	1	26.1	1.75
CMLXPL4230	314	42	30	1	32.59	2.19
CMLXPL4236	361	42	36	1	39.07	2.63
CMLXPL4242	454	42	42	1	45.56	3.06
CMLXPL4248	469	42	48	1	52.05	3.50
CMLXPL4812	159	48	12.3	1	14.95	0.34
CMLXPL4824	276	48	24	1	29.85	2.00
CMLXPL4830	324	48	30	1	37.27	2.50
CMLXPL4836	372	48	36	1	44.7	3.00
CMLXPL4842	469	48	42	1	52.12	3.50
CMLXPL4848	482	48	48	1	59.55	4.00
CMLXPL5412	177	54	12.3	1	16.83	0.38
CMLXPL5424	295	54	24	1	33.55	2.25
CMLXPL5430	346	54	30	1	41.92	2.81
CMLXPL5436	397	54	36	1	50.28	3.38
CMLXPL5442	450	54	42	1	58.64	3.94
CMLXPL5448	552	54	48	1	67.01	4.50

CMLXPR • Right Extension End of Run Return Gallery Panel With End Connection

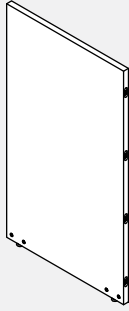

- Provides floor standing support while enclosing the end of a gallery panel run.
- Attached at the end of a panel to allow for extending the gallery panel run.
- Connections are at both exposed ends, one to connect to the panel and one to connect to another gallery panel.
- Includes all attachment hardware and glides.
- Total height is inclusive of panel glides extended to their full height.
- Please specify LP laminate finish and PVC edge finish.
- If a wood grain laminate is chosen, grain direction run horizontally.
- Gallery panel is edged in PVC on exposed edges and self edged on edge connecting to panel.

PRODUCT CODE	PRICE LP	SIZE/INCHES			WEIGHT VOL	
		H	W	D	LBS	FT ³
CMLXPR4212	142	42	12.3	1	13.08	0.30
CMLXPR4224	268	42	24	1	26.1	1.75
CMLXPR4230	314	42	30	1	32.59	2.19
CMLXPR4236	361	42	36	1	39.07	2.63
CMLXPR4242	454	42	42	1	45.56	3.06
CMLXPR4248	469	42	48	1	52.05	3.50
CMLXPR4812	159	48	12.3	1	14.95	0.34
CMLXPR4824	276	48	24	1	29.85	2.00
CMLXPR4830	324	48	30	1	37.27	2.50
CMLXPR4836	372	48	36	1	44.7	3.00
CMLXPR4842	469	48	42	1	52.12	3.50
CMLXPR4848	482	48	48	1	59.55	4.00
CMLXPR5412	177	54	12.3	1	16.83	0.38
CMLXPR5424	295	54	24	1	33.55	2.25
CMLXPR5430	346	54	30	1	41.92	2.81
CMLXPR5436	397	54	36	1	50.28	3.38
CMLXPR5442	450	54	42	1	58.64	3.94
CMLXPR5448	552	54	48	1	67.01	4.50

CMLXPL-NC • Extension End of Run, Left, No Connection

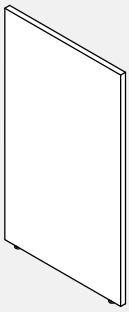

- Provides floor standing support while enclosing the end of a gallery panel run.
- Attached at the end of a gallery panel to extend the gallery panel run.
- Connections only at one exposed end.
- Includes all attachment hardware and glides.
- Total height is inclusive of panel glides extended to their full height.
- Please specify LP laminate finish and PVC edge finish.
- If a wood grain laminate is chosen, grain direction run horizontally.
- Gallery panel is edged in PVC on exposed edges and self edged on edge connecting to panel.

PRODUCT CODE	PRICE LP	SIZE/INCHES			WEIGHT VOL	
		H	W	D	LBS	FT ³
CMLXPL4224NC	265	42	24	1	26.05	1.75
CMLXPL4230NC	312	42	30	1	32.54	2.19
CMLXPL4236NC	359	42	36	1	39.03	2.63
CMLXPL4242NC	452	42	42	1	45.52	3.06
CMLXPL4248NC	465	42	48	1	52.01	3.50
CMLXPL4824NC	274	48	24	1	29.8	2.00
CMLXPL4830NC	323	48	30	1	37.23	2.50
CMLXPL4836NC	370	48	36	1	44.66	3.00
CMLXPL4842NC	465	48	42	1	52.08	3.50
CMLXPL4848NC	480	48	48	1	59.51	4.00
CMLXPL5424NC	293	54	24	1	33.55	2.25
CMLXPL5430NC	344	54	30	1	41.92	2.81
CMLXPL5436NC	396	54	36	1	50.28	3.38
CMLXPL5442NC	448	54	42	1	58.64	3.94
CMLXPL5448NC	550	54	48	1	67.01	4.50

CMLXPR-NC • Extension End of Run, Right, No Connection

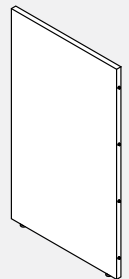

- Provides floor standing support while enclosing the end of a gallery panel run.
- Attached at the end of a gallery panel to extend the gallery panel run.
- Connections only at one exposed end.
- Includes all attachment hardware and glides.
- Total height is inclusive of panel glides extended to their full height.
- Please specify LP laminate finish and PVC edge finish.
- If a wood grain laminate is chosen, grain direction run horizontally.
- Gallery panel is edged in PVC on exposed edges and self edges on edge connecting to panel.

PRODUCT CODE	PRICE LP	SIZE/INCHES			WEIGHT VOL	
		H	W	D	LBS	FT ³
CMLXPR4224NC	265	42	24	1	26.05	1.75
CMLXPR4230NC	312	42	30	1	32.54	2.19
CMLXPR4236NC	359	42	36	1	39.03	2.63
CMLXPR4242NC	452	42	42	1	45.52	3.06
CMLXPR4248NC	465	42	48	1	52.01	3.5
CMLXPR4824NC	274	48	24	1	29.8	2
CMLXPR4830NC	323	48	30	1	37.23	2.5
CMLXPR4836NC	370	48	36	1	44.66	3
CMLXPR4842NC	465	48	42	1	52.08	3.5
CMLXPR4848NC	480	48	48	1	59.51	4
CMLXPR5424NC	293	54	24	1	33.55	2.25
CMLXPR5430NC	344	54	30	1	41.92	2.81
CMLXPR5436NC	396	54	36	1	50.28	3.38
CMLXPR5442NC	448	54	42	1	58.64	3.94
CMLXPR5448NC	550	54	48	1	67.01	4.5

CMHLPBB01 • Gallery Panel Bracket

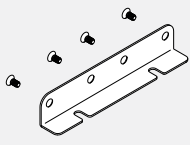

- Gallery panel bottom bracket connects two gallery end panels at bottom with screws.
- Available in standard paint colors.
- Screws are included with the bracket.

PRODUCT CODE	PRICE	SIZE/INCHES			WEIGHT VOL	
		H	W	D	LBS	FT ³
CMHLPBB01	35	1.5	8.00	1	0.5	0.11

CMHLPCB01 • Gallery Panel Corner Bracket

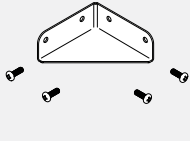

- Gallery panel corner bottom bracket connects two laminate panels at 90 degrees.
- Available in standard paint colors.
- Screws are included with the bracket.

PRODUCT CODE	PRICE	SIZE/INCHES			WEIGHT VOL	
		H	W	D	LBS	FT ³
CMHLPCB01	34	1.5	4.00	4	0.5	0.11

CMPMP-GI-W • Privacy Glass for 1" Laminate Gallery Panels

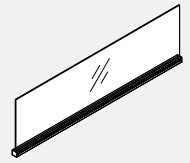

- **Privacy glass integrated with aluminum top trim.**
- Attaches on top of gallery panels to add privacy or divide space.
- Includes aluminum trim with channel, end caps and glass tile.
- Top rail may also be used to hang accessories.
- Glass and attachment hardware ship separately.
- Please specify standard paint finish for the channel.
- Standard in clear (CLR) or frosted (FRST).

PRODUCT CODE	PRICE	FRST	SIZE/INCHES			WEIGHT LBS	VOL FT ³
			H	W	D		
CMPMP24GI6W	201	251	6	24	1	3.58	0.08
CMPMP30GI6W	219	276	6	30	1	4.48	0.10
CMPMP36GI6W	235	291	6	36	1	5.37	0.13
CMPMP42GI6W	251	313	6	42	1	6.26	0.15
CMPMP48GI6W	262	327	6	48	1	7.16	0.17
CMPMP24GI9W	201	251	9	24	1	4.77	0.13
CMPMP30GI9W	219	276	9	30	1	5.97	0.16
CMPMP36GI9W	235	291	9	36	1	7.16	0.19
CMPMP42GI9W	251	313	9	42	1	8.35	0.22
CMPMP48GI9W	262	327	9	48	1	9.55	0.25
CMPMP24GIW	201	251	12	24	1	4.77	0.17
CMPMP30GIW	219	276	12	30	1	5.97	0.21
CMPMP36GIW	235	291	12	36	1	7.16	0.25
CMPMP42GIW	251	313	12	42	1	8.35	0.29
CMPMP48GIW	262	327	12	48	1	9.55	0.33

CMPFD-W • Privacy Felt for 1" Laminate Gallery Panels

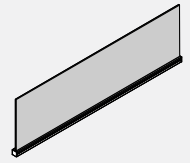

- **Privacy felt integrated with aluminum top trim.**
- Attaches on top of gallery panels to add privacy or divide space.
- Includes aluminum trim with channel, end caps and felt tile.
- Top rail may also be used to hang accessories.
- Felt and attachment hardware ship separately.
- Please specify standard paint finish for the channel.
- Please specify standard felt finish.

PRODUCT CODE	PRICE	SIZE/INCHES			WEIGHT LBS	VOL FT ³
		H	W	D		
CMPFD0624W	72	6	24	1	1.42	0.08
CMPFD0630W	88	6	30	1	1.73	0.10
CMPFD0636W	102	6	36	1	2.03	0.13
CMPFD0642W	114	6	42	1	2.34	0.15
CMPFD0648W	170	6	48	1	2.64	0.17
CMPFD0654W	183	6	54	1	2.95	0.19
CMPFD0660W	199	6	60	1	3.25	0.21
CMPFD0666W	210	6	66	1	3.56	0.23
CMPFD0672W	238	6	72	1	3.86	0.25
CMPFD0924W	72	9	24	1	2.26	0.13
CMPFD0930W	88	9	30	1	2.77	0.16
CMPFD0936W	102	9	36	1	3.29	0.19
CMPFD0942W	114	9	42	1	3.8	0.22
CMPFD0948W	170	9	48	1	4.32	0.25
CMPFD0954W	183	9	54	1	4.83	0.28
CMPFD0960W	199	9	60	1	5.35	0.31
CMPFD0966W	210	9	66	1	6.68	0.34
CMPFD0972W	238	9	72	1	7.2	0.38
CMPFD1224W	72	12	24	1	2.26	0.17
CMPFD1230W	88	12	30	1	2.77	0.21
CMPFD1236W	102	12	36	1	3.29	0.25
CMPFD1242W	114	12	42	1	3.8	0.29
CMPFD1248W	170	12	48	1	4.32	0.33
CMPFD1254W	183	12	54	1	4.83	0.38
CMPFD1260W	199	12	60	1	5.35	0.42
CMPFD1266W	210	12	66	1	6.68	0.46
CMPFD1272W	238	12	72	1	7.2	0.50

CHP • 90 Degree Corner Post Kits



- Standard Compile paint options.
- Specify the corner post height that matches the tallest or smallest panel connection.
- 6" shorter than panel height to accommodate electric in base.
- Made of aluminum.
- 2-Way Kits include 2 trims (CMETP), 2 way post base (CMPC) and post cap (CMPC).
- 3-Way Kits include 1 trim (CMTEP), 3 way post base (CMPC) and post cap (CMPC).
- 4 Way Kits includes post cap (CMPC) only.

PRODUCT CODE	PRICE	SIZE/ H	INCHES			WEIGHT VOL	
			W	D	LBS	FT ³	
2-Way Kits							
CHP30-2	104	30	2.3	2.3	5	0.22	
CHP42-2	104	42	2.3	2.3	5	0.22	
CHP46-2	109	46	2.3	2.3	5	0.22	
CHP48-2	126	48	2.3	2.3	5	0.22	
CHP54-2	126	54	2.3	2.3	5	0.22	
CHP58-2	136	58	2.3	2.3	5	0.22	
CHP60-2	136	60	2.3	2.3	5	0.22	
CHP64-2	158	64	2.3	2.3	5	0.22	
CHP66-2	151	66	2.3	2.3	5	0.22	
CHP70-2	161	70	2.3	2.3	5	0.22	
CHP72-2	158	72	2.3	2.3	5	0.22	
CHP78-2	179	78	2.3	2.3	5	0.22	
CHP82-2	190	82	2.3	2.3	5	0.22	
CHP90-2	190	90	2.3	2.3	5	0.22	
3-Way Kits							
CHP30-3	91	30	2.3	2.3	5	0.22	
CHP42-3	91	42	2.3	2.3	5	0.22	
CHP46-3	100	46	2.3	2.3	5	0.22	
CHP48-3	110	48	2.3	2.3	5	0.22	
CHP54-3	110	54	2.3	2.3	5	0.22	
CHP58-3	124	58	2.3	2.3	5	0.22	
CHP60-3	124	60	2.3	2.3	5	0.22	
CHP64-3	132	64	2.3	2.3	5	0.22	
CHP66-3	136	66	2.3	2.3	5	0.22	
CHP70-3	143	70	2.3	2.3	5	0.22	
CHP72-3	143	72	2.3	2.3	5	0.22	
CHP78-3	161	78	2.3	2.3	5	0.22	
CHP82-3	170	82	2.3	2.3	5	0.22	
CHP90-3	187	90	2.3	2.3	5	0.22	
4-Way Kits							
CHP30-4	68	30	2.3	2.3	5	0.22	
CHP42-4	68	42	2.3	2.3	5	0.22	
CHP46-4	90	46	2.3	2.3	5	0.22	
CHP48-4	89	48	2.3	2.3	5	0.22	
CHP54-4	89	54	2.3	2.3	5	0.22	
CHP58-4	102	58	2.3	2.3	5	0.22	
CHP60-4	102	60	2.3	2.3	5	0.22	
CHP64-4	106	64	2.3	2.3	5	0.22	
CHP66-4	112	66	2.3	2.3	5	0.22	
CHP70-4	116	70	2.3	2.3	5	0.22	
CHP72-4	116	72	2.3	2.3	5	0.22	
CHP78-4	133	78	2.3	2.3	5	0.22	
CHP82-4	139	82	2.3	2.3	5	0.22	
CHP90-4	156	90	2.3	2.3	5	0.22	

CHOP • 90 Degree Corner Post Kits for Over Panels



- Standard Compile paint options.
- Specify the corner post height that matches the height of the over panel
- Made of aluminum.

PRODUCT CODE	PRICE	SIZE/ H	INCHES			WEIGHT VOL	
			W	D	LBS	FT ³	
CHOP12-4	27	12	2.3	2.3	5	0.22	
CHOP16-4	41	16	2.3	2.3	5	0.22	
CHOP24-4	40	24	2.3	2.3	5	0.22	

CHP2W • 60 Degree 2 Way Corner Post



- Standard Compile paint options.
- Specify the corner post height that matches the tallest or smallest panel connection.
- Note: Made of aluminum.
- Outer part is full panel height, inner part is 6" shorter.
- Post cap included.

PRODUCT CODE	PRICE	SIZE/ INCHES			WEIGHT VOL	
		H	W	D	LBS	FT ³
CHP2W30	68	30	2.3	2.3	5	0.22
CHP2W42	68	42	2.3	2.3	5	0.22
CHP2W46	75	46	2.3	2.3	5	0.22
CHP2W48	89	48	2.3	2.3	5	0.22
CHP2W54	89	54	2.3	2.3	5	0.22
CHP2W58	93	58	2.3	2.3	5	0.22
CHP2W60	103	60	2.3	2.3	5	0.22
CHP2W64	112	64	2.3	2.3	5	0.22
CHP2W66	112	66	2.3	2.3	5	0.22
CHP2W70	117	70	2.3	2.3	5	0.22
CHP2W72	117	72	2.3	2.3	5	0.22
CHP2W78	133	78	2.3	2.3	5	0.22
CHP2W82	139	82	2.3	2.3	5	0.22
CHP2W90	153	90	2.3	2.3	5	0.22

CHP3W • 60 Degree 3 Way Corner Post



- Standard Compile paint options.
- Specify the corner post height that matches the tallest or smallest panel connection.
- 6" shorter than panel height to accommodate electric in base.
- Note: Made of aluminum.
- Actual post size is 6" shorter than panel height.
- Post cap included.

PRODUCT CODE	PRICE	SIZE/ INCHES			WEIGHT VOL	
		H	W	D	LBS	FT ³
CHP3W30	68	30	2.3	2.3	5	0.22
CHP3W42	68	42	2.3	2.3	5	0.22
CHP3W46	75	46	2.3	2.3	5	0.22
CHP3W48	89	48	2.3	2.3	5	0.22
CHP3W54	89	54	2.3	2.3	5	0.22
CHP3W58	93	58	2.3	2.3	5	0.22
CHP3W60	103	60	2.3	2.3	5	0.22
CHP3W64	112	64	2.3	2.3	5	0.22
CHP3W66	112	66	2.3	2.3	5	0.22
CHP3W70	117	70	2.3	2.3	5	0.22
CHP3W72	117	72	2.3	2.3	5	0.22
CHP3W78	133	78	2.3	2.3	5	0.22
CHP3W82	139	82	2.3	2.3	5	0.22
CHP3W90	153	90	2.3	2.3	5	0.22

CMPC • 90 Degree Post Cap

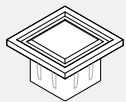

- Included with any post.
- Specified separately for reconfiguration purposes.
- Available in standard Compile paint options.

PRODUCT CODE	PRICE	SIZE/ INCHES			WEIGHT VOL	
		H	W	D	LBS	FT ³
CMPC	8	0.7	2.5	2.5	0.02	0.01

CMPC • 60 Degree Post Cap

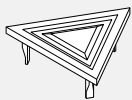

- Included with any post.
- Specified separately for reconfiguration purposes.
- Available in standard Compile paint options.

PRODUCT CODE	PRICE	SIZE/ INCHES			WEIGHT VOL	
		H	W	D	LBS	FT ³
CMPC60	8	0.7	2.5	2.5	0.02	0.01

CMPC • Post Base Cover

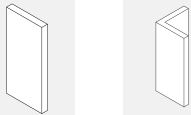

- Included with any post kit.
- Specified separately for reconfiguration purposes.
- Available in standard Compile paint options.
- Available for 2-way and 3-way configurations.
- Note: Finish is smooth plastic.

PRODUCT CODE	PRICE	SIZE/INCHES			WEIGHT VOL		
		H	W	D	LBS	FT ³	
CMPC1	12	3-Way	5	2.3	0.33	0.04	0.02
CMPC2	13	2-Way	5	2.3	2.31	0.08	0.04

CEPE • Data Post Extension



- Data Post extension comes with 4 trims, 3 brackets, connecting hardware and ceiling bezel and two post clips.
- Data Post extension available in standard Compile paint options. (Ceiling bezel available in white only.)
- Includes cut out along the post for easy cable insert.

PRODUCT CODE	PRICE	SIZE/INCHES			WEIGHT VOL	
		H	W	D	LBS	FT ³
CEPE64	190	64	2.3	2.3	9	0.42
CEPE82	245	82	2.3	2.3	9	0.42

CMET • End of Run Insert for Panel



- End of Run inserts are not included with panels.
- Cannot be used for a 60° and 90° post application.
- Used at the end of each panel run and cannot be used to attach a panel run to a fixed wall.
- Vertical trims must be specified separately. Trim snaps in the panel at the end of run.
- Available in standard Compile paint options.

PRODUCT CODE	PRICE	SIZE/INCHES			WEIGHT VOL	
		H	W	D	LBS	FT³
CMET16	12	16	2.3	0.5	0.12	0.01
CMET30	14	30	2.3	0.5	0.12	0.05
CMET42	14	42	2.3	0.5	0.74	0.05
CMET46	14	46	2.3	0.5	0.74	0.05
CMET48	14	48	2.3	0.5	0.82	0.18
CMET54	14	54	2.3	0.5	0.90	0.18
CMET58	15	58	2.3	0.5	0.9	0.18
CMET60	15	60	2.3	0.5	1.48	0.31
CMET64	19	64	2.3	0.5	1.48	0.31
CMET66	19	66	2.3	0.5	1.48	0.31
CMET70	20	70	2.3	0.5	1.48	0.31
CMET72	20	72	2.3	0.5	1.48	0.31
CMET78	21	78	2.3	0.5	2.06	0.44
CMET82	22	82	2.3	0.5	2.06	0.44
CMET90	24	90	2.3	0.5	2.06	0.44

CMET • End of Run Trim Insert for Step Down



- Specify for any step down application and to meet the taller post or panel.
- Trim snaps in the post or end of run at a change in height.
- Available in standard Compile paint options.

PRODUCT CODE	PRICE	SIZE/INCHES			WEIGHT VOL	
		H	W	D	LBS	FT³
CEMT06	5	6	2.3	0.5	0.06	0.05
CMET12	9	12	2.3	0.5	0.12	0.05
CMET24	12	24	2.3	0.5	0.12	0.05
CMET36	14	36	2.3	0.5	0.12	0.05

CMETP • Trim Insert for Corner Post



- Trim installs on all sides of an exposed Corner Post.
- Specify to equal post height.
- Vertical trims must be specified separately. Trim snaps in the post.
- Available in standard Compile paint options.

PRODUCT CODE	PRICE	SIZE/INCHES			WEIGHT VOL	
		H	W	D	LBS	FT³
CMETP30	14	30	2.3	0.5	0.12	0.05
CMETP42	14	42	2.3	0.5	0.74	0.05
CMETP46	14	46	2.3	0.5	0.74	0.05
CMETP48	16	48	2.3	0.5	0.82	1.18
CMETP54	16	54	2.3	0.5	0.90	0.18
CMETP58	16	58	2.3	0.5	0.9	0.18
CMETP60	16	60	2.3	0.5	2.06	0.44
CMETP64	19	64	2.3	0.5	1.48	0.31
CMETP66	19	66	2.3	0.5	1.48	0.31
CMETP70	19	70	2.3	0.5	1.48	0.31
CMETP72	19	72	2.3	0.5	2.06	0.44
CMETP78	21	78	2.3	0.5	2.06	0.44
CMETP82	22	82	2.3	0.5	2.06	0.44
CMETP90	24	90	2.3	0.5	2.06	0.44

CHWA • Wall Mount Extrusion



- Starts a run of panels off an existing wall.
- Includes panel connectors.
- Mounting hardware not included. The mounting hardware selected must be based on the wall or wall stud material.
- Wall adapter adds 5/16" to a panel run.

PRODUCT CODE	PRICE	SIZE/INCHES			WEIGHT VOL	
		H	W	D	LBS	FT³
CHWA30	37	30	2.3	0.5	0.12	0.05
CHWA42	37	42	2.3	0.5	0.74	0.05
CHWA54	46	54	2.3	0.5	0.90	0.18
CHWA66	56	66	2.3	0.5	1.48	0.31

CWMA • Wall Vertical Channel



- Used to attach system components to fixed wall.
- Panel frame finish.
- Comes in 60" length only.
- Care should be taken to mount adapters only to wall studs using correct fasteners.
- Does not include mounting hardware. Mounting hardware selection to be based on wall material.
- Sold in pairs.
- Failure to do this may result in collapse of the unit and subsequent possible personal injury.

PRODUCT CODE	PRICE	SIZE/INCHES			WEIGHT VOL	
		H	W	D	LBS	FT³
CWMA60	31	60	0.6	0.7	1.07	0.006

CHHF01 • High Profile Foot

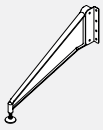

- Provides added support to a panel or worksurface under load.
- Includes Compile attachment bracket and two levelling glides to adapt to different panel clearances.

PRODUCT CODE	PRICE	SIZE/INCHES			WEIGHT VOL	
		H	W	D	LBS	FT ³
CHHF01	249	6	1	21	2.80	0.15

CMPS01 • Post Separator

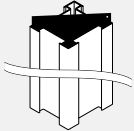

- Creates a diagonal division within a compile post.
- Please specify post height.

PRODUCT CODE	PRICE	SIZE/INCHES			WEIGHT VOL	
		H	W	D	LBS	FT ³
CMPS01	136	96	3.25	14 guage	0.01	0.015

CBEZEL • Post Extension Bezel

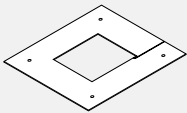

- Finishes the connection between post extension and ceiling.
- Comes in white only.
- Includes screws.

PRODUCT CODE	PRICE	SIZE/INCHES			WEIGHT VOL	
		H	W	D	LBS	FT ³
CBEZEL	12	0.06	6	6	0.01	0.006

CMRC • Raceway Cover Without Punchouts (Each)

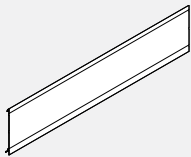

- Durable extruded aluminum.

PRODUCT CODE	PRICE	SIZE/INCHES			WEIGHT VOL	
		H	W	D	LBS	FT ³
CMRC24NP	16	5	24	0.8	1.9	0.06
CMRC30NP	21	5	30	0.8	2.0	0.06
CMRC36NP	23	5	36	0.8	2.2	0.07
CMRC42NP	25	5	42	0.8	2.5	0.08
CMRC48NP	27	5	48	0.8	2.9	0.09
CMRC54NP	34	5	54	0.8	3.2	0.10
CMRC60NP	36	5	60	0.8	3.7	0.11

CMHLPF • Flat Leg for Freestanding Panels

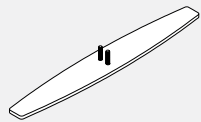

- Single flat leg for end of run/wing applications where the customer is looking for more stability.
- Kit will contains one legs and all attachment hardware.
- For the installation the customer will have to remove the existing levelers on the panel and replace it with the legs.
- Please specify paint finish.

PRODUCT CODE	PRICE	SIZE/ INCHES			WEIGHT VOL	
		H	W	D	LBS	FT ³
CMHLPF01	81	0.31	21	3	3	0.01

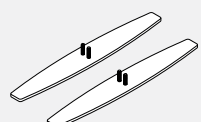

- Double kit for freestanding applications.
- Kit will contains two legs and all attachment hardware.
- For the installation the customer will have to remove the existing levelers on the panel and replace it with the legs.
- Please specify paint finish.

PRODUCT CODE	PRICE	SIZE/ INCHES			WEIGHT VOL	
		H	W	D	LBS	FT ³
CMHLPF02	162	0.31	21	3	6	0.02

CMHLLP01 • Low Profile Foot

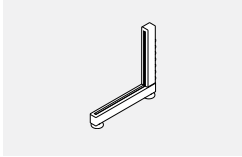

- Provides added support to a panel under load.
- Adjustable glides and connectors included.
- Made of powder coated steel.
- Please choose panel frame finish.

PRODUCT CODE	PRICE	SIZE/INCHES			WEIGHT VOL	
		H	W	D	LBS	FT ³
CMHLLP01	123	12	11	1.1	2.87	0.08

CMHLLP02 • Low Profile Foot, Set of 2

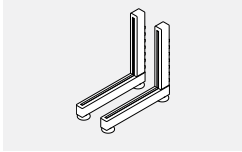

- Provides added support to a panel under load.
- Adjustable glides and connectors included.
- Made of powder coated steel.
- Please choose panel frame finish.
- Set includes 2 complete legs.

PRODUCT CODE	PRICE	SIZE/INCHES			WEIGHT VOL	
		H	W	D	LBS	FT ³
CMHLLP02	245	12	11	1.1	5.74	0.17

CMRCB01 • Electrical Blank Cover

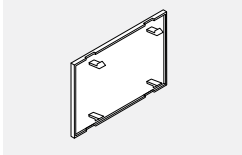

- Fills punchout when opening is not used.
- Available in Black (BLK), Tungsten (TUN), White (WHT) and Nevada (NEV).
- Note: Punchout covers are made of plastic.

PRODUCT CODE	PRICE	SIZE/INCHES			WEIGHT VOL	
		H	W	D	LBS	FT ³
CMRCB01	14	1.5	2.756	0.01	0.04	0.02

CMRC • Raceway Cover With Punchouts (Each)

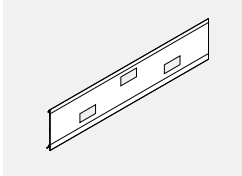

- Cover not included
- Raceway Punchout Cover must be added to openings where duplex receptacles are not used.
- Durable extruded aluminum.
- 24" wide panels have two punchouts, one for electrical and one for data.
- 30" wide panels and wider have three punchouts, two for electrical and one for data.

PRODUCT CODE	PRICE	SIZE/INCHES			WEIGHT VOL	
		H	W	D	LBS	FT ³
CMRC24PO	16	5	24	0.8	1.9	0.06
CMRC30PO	21	5	30	0.8	2.0	0.06
CMRC36PO	23	5	36	0.8	2.2	0.07
CMRC42PO	25	5	42	0.8	2.5	0.08
CMRC48PO	27	5	48	0.8	2.9	0.09
CMRC54PO	34	5	54	0.8	3.2	0.10
CMRC60PO	36	5	60	0.8	3.7	0.11
CMRC66PO	40	5	66	0.8	4.0	0.12
CMRC72PO	44	5	72	0.8	4.4	0.13

CM0100LKCLIP • Lock Clip

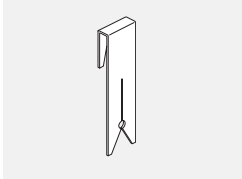

- Use to hold and lock 2 panels or panel post together and prevents disconnection.

PRODUCT CODE	PRICE	SIZE/INCHES			WEIGHT VOL	
		H	W	D	LBS	FT ³
CM0100LKCLIP	8	2.6	0.75	0.32	0.026	0.001

CPN01 • Name Plate

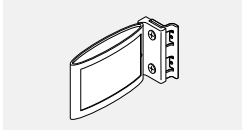

- Name plate can be set either as a single-sided (parallel to panel surface) or double-sided (perpendicular to panel surface - for isle applications, displaying name on both sides).
- Injection molded frame and die-cast base with black rubberized finish. Steel bracket and fasteners included.
- Includes two slide-in name cards.

PRODUCT CODE	PRICE	SIZE/ INCHES			WEIGHT VOL	
		H	W	D	LBS	FT ³
CPNP01	74	3.3	5.3	1.25	0.3	0.013

CE8PD • Power Distribution Housing

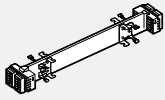

- Power distribution housing is specified per panel size (e.g. CE8PD36 is for use in a 36" panel).
- 8 wire, 4 circuits (A and B circuit dedicated). Provides two duplex receptacles per panel side on all panel widths except the 24" wide panel.
- 24" wide panel allows for only one (1) duplex receptacle on one panel side.
- Each power distribution housing supports 15 amps.
- Must specify Raceway Cover with punchouts on panels, where Power Distribution Housings will be utilized. (Panel Kits P1 and P2)

PRODUCT CODE	PRICE	SIZE/INCHES			WEIGHT VOL	
		H	W	D	LBS	FT ³
CE8PD24	156	2	9.25	2.3	0.83	1.17
CE8PD30	208	2	15.25	2.3	1.28	1.17
CE8PD36	220	2	21.25	2.3	1.62	1.65
CE8PD42	226	2	27.25	2.3	2.00	2.00
CE8PD48	238	2	33.25	2.3	2.32	2.54
CE8PD54	242	2	39.25	2.3	2.66	3.20
CE8PD60	243	2	45.25	2.3	3.04	3.20
CE8PD66	253	2	51.25	2.3	3.42	3.48
CE8PD72	262	2	57.25	2.3	3.80	3.48

CE8CP • 17" Mesh Jumper Cable

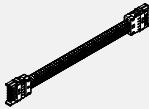

- 17" mesh jumper.
- Jumper cable is used to pass through a post or connect two panels together.

PRODUCT CODE	PRICE	SIZE/INCHES			WEIGHT VOL	
		H	W	D	LBS	FT ³
CE8CP17	149	2	17	0.5	0.71	0.67

CE8CP • Pass Through Cable

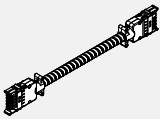

- Flexible metal conduit is used to distribute electrical power through non-powered panels.
- Metal conduit pass through cables should be in used in a straight runs. Metal conduit pass through cables cannot go around a post.
- Flexible conduit is required to turn a post. This only comes as 17"w. If panels at the posts do not all have power distribution housings, they must be added even if duplexes are not specified.
- To calculate the length of a Pass-Through Cable, add the widths of the non-powered panels separating the powered panels (panels with distribution housing attached). To this add 16" (distance from the edge of the panel to the distribution housing x 2).
- Add additional 3" when passing through a corner post.

PRODUCT CODE	PRICE	SIZE/INCHES			WEIGHT VOL	
		H	W	D	LBS	FT ³
CE8CP40	164	2	40.5	0.5	1.44	1.17
CE8CP46	169	2	46.5	0.5	1.71	1.17
CE8CP52	177	2	52.5	0.5	1.95	1.17
CE8CP58	188	2	58.5	0.5	2.21	1.17
CE8CP64	196	2	64.5	0.5	2.37	1.17
CE8CP70	200	2	70.5	0.5	2.60	1.17
CE8CP76	204	2	76.5	0.5	2.81	1.17
CE8CP82	213	2	82.5	0.5	3.03	1.17
CE8CP88	220	2	88.5	0.5	3.05	1.17
CE8CP94	228	2	94.5	0.5	3.30	1.17
CE8CP100	233	2	100.5	0.5	3.47	1.17
CE8CP106	243	2	106.5	0.5	3.87	1.17
CE8CP118	257	2	118.5	0.5	4.08	1.17
CE8CP130	281	2	130.5	0.5	4.73	1.17
CE8CP142	293	2	142.5	0.5	4.99	1.17

CE8CI • "I" Connector

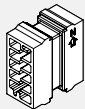

- Female - Female connector connects two Pass-Through Cables .
- Connects 17" Flexible Jumper Cable or ceiling feeds to pass through cables.

PRODUCT CODE	PRICE	SIZE/INCHES			WEIGHT VOL	
		H	W	D	LBS	FT ³
CE8CI1	81	1.5	1.5	4.625	0.06	0.03

CE8RD • Duplex Receptacle

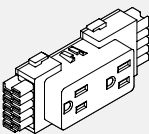

- Up to 6 receptacles per circuit.
- Duplex Receptacles standard in Black (BLK).
- CE8RD1 = Circuit #1 (utility circuit)
- CE8RD2 = Circuit #2 (utility circuit)
- CE8RDA = Circuit A (dedicated)
- CE8RDB = Circuit B (dedicated)
- Note:
- CE8RD1 and CE8RD2 (#1 and #2 share common ground)
- CE8RDA and CE8RDB (A and B share dedicated ground)

PRODUCT CODE	PRICE	SIZE/INCHES			WEIGHT VOL	
		H	W	D	LBS	FT ³
CE8RD1	35	2	4.625	1.25	0.10	0.01
CE8RD2	35	2	4.625	1.25	0.10	0.01
CE8RDA	35	2	4.625	1.25	0.10	0.01
CE8RDB	35	2	4.625	1.25	0.10	0.01

CMEUSB • USB Receptacle

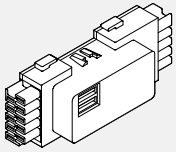

- USB charging module provides convenient charging power access through dual ports on face of the receptacle.
- Two USB ports.
- 2 Amp output via two USB ports.

PRODUCT CODE	PRICE	SIZE/INCHES			WEIGHT VOL	
		H	W	D	LBS	FT ³
CMEUSB01WHT	238	2	4.625	1.25	0.10	0.01
CMEUSB01BLK	238	2	4.625	1.25	0.10	0.01

CE8EC • Ceiling Power Entry

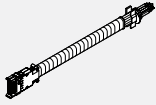

- Snaps into the end of Power Distribution Housing.
- Flexible metal conduit extends into the ceiling through a corner post and post extension (both ordered separately).
- Must be hard wired to source power by a licensed electrician.
- 4" Junction Box included.

PRODUCT CODE	PRICE	SIZE/INCHES			WEIGHT VOL	
		H	L	D	LBS	FT ³
CE8EC1	268	2	132	0.5	5.24	2.00
CE8EC2	479	2	144	0.5	5.96	2.00

CE8FR • Base Feed

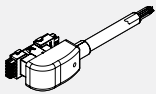

- Takes the place of a duplex receptable by snapping into the base power way.
- CE8FR1 Includes 72" long flexible metal conduit. CE8FR2 Includes 144" long flexible metal conduit.
- Must be hard wired to source power by a licensed electrician.

PRODUCT CODE	PRICE	SIZE/INCHES			WEIGHT VOL	
		H	W	D	LBS	FT ³
CE8FR1	353	6	72	3	3.82	2
CE8FR2	454	6	144	3	5.96	2

GCLEDES • Undercabinet LED Task Light

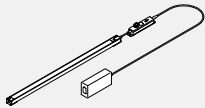

- Linear LED Light.
- Includes light fixture with lens and ON/OFF switch.
 - Magnet mounted with adhesive metal plates.
 - Plug-in power supply with 72" cord length plus 78" DC cord.
- Technical information:
- 4100 K Colour Temperature
 - 90 Colour Rendering Index
 - 30,000 hrs rated Lifespan
 - Total power input per light, 9.0 for 24", 13.5 per 36" and 18.0 for 48"

PRODUCT CODE	PRICE	SIZE/	INCHES		WEIGHT VOL	
		H	W	D	LBS	FT ³
GCLEDES24	164	1	22.9	1	2.5	0.135
GCLEDES36	189	1	33.5	1	2.8	0.161
GCLEDES48	209	1	45.5	1	3.2	0.213

GCLEDES-DCS • Undercabinet Daisychain LED Light

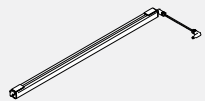

- Undercabinet LED light, 48 inches nominal size , daisychain unit with 1 meter (39 inches) linking cable but no power supply.
- Daisychain units can only be linked up to a total of 48 Watts for all lights on one power supply. This equates to a maximum of 10 feet total nominal length of lights per power supply.

- Technical information:
- 4100 K Colour Temperature
 - 90 Colour Rendering Index
 - 30,000 hrs rated Lifespan
 - Total power input per light, 9.0 for 24", 13.5 per 36" and 18.0 for 48"

PRODUCT CODE	PRICE	SIZE/	INCHES		WEIGHT VOL	
		H	W	D	LBS	FT ³
GCLEDES24DSC	134	1	24	1	2.5	0.135
GCLEDES36DSC	157	1	36	1	2.8	0.161
GCLEDES48DSC	178	1	48	1	3.2	0.213

GCLEDESOS • Occupancy Sensor and Dimmer

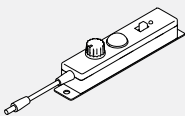

- Inline add-on controller for dimming & occupancy sensor.
- Included, from right to left, a rotary dimmer control, an occupancy sensor and a sensor bypass switch.

PRODUCT CODE	PRICE	SIZE/	INCHES		WEIGHT VOL	
		H	W	D	LBS	FT ³
GCLEDESOS	66	6	2.5	2	0.4	0.500

CWS • Rectangular Worksurface

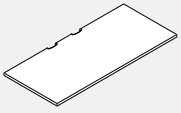

- All tops are thermally fused 1" thick with pilot holes to enable proper alignment with worksurface supports. Wood screws must be used.
- Compile worksurfaces feature a 3mm edge.
- Support hardware must be ordered separately.
- All surfaces longer than 54" have 2 scoops, all others have one.
- Please choose from DWT - Designer White, SIL- Silver or BLK - Black for scoop covers.
- Note: Width and depth dimensions listed include a nominal measurement (3/8") to account for wire management between the worksurface and adjoining panel.

PRODUCT CODE	PRICE LP	SIZE/INCHES			WEIGHT LBS	VOL FT ³
		H	W	D		
CWS2424P	133	1	24	24	16	0.52
CWS2430P	145	1	30	24	20	0.62
CWS2436P	161	1	36	24	23	0.78
CWS2442P	211	1	42	24	28	0.90
CWS2448P	252	1	48	24	31	1.03
CWS2454P	299	1	54	24	35	1.20
CWS2460P	336	1	60	24	39	1.30
CWS2466P	350	1	66	24	43	1.41
CWS2472P	366	1	72	24	47	1.54
CWS2478P	392	1	78	24	51	1.70
CWS2484P	422	1	84	24	55	1.80
CWS2490P	486	1	90	24	58	1.96
CWS2496P	517	1	96	24	63	2.10
CWS3024P	159	1	24	30	20	0.70
CWS3030P	170	1	30	30	25	0.97
CWS3036P	200	1	36	30	30	1.06
CWS3042P	283	1	42	30	34	1.12
CWS3048P	299	1	48	30	39	1.30
CWS3054P	327	1	54	30	44	1.44
CWS3060P	350	1	60	30	49	1.60
CWS3066P	364	1	66	30	54	1.80
CWS3072P	385	1	72	30	59	2.00
CWS3078P	410	1	78	30	64	2.10
CWS3084P	456	1	84	30	69	2.24

CWSNSCP • Rectangular Worksurface, No Scoops

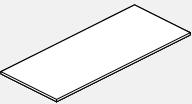

- All tops are thermally fused 1" thick with pilot holes to enable proper alignment with worksurface supports. Wood screws must be used.
- Compile worksurfaces feature a 3mm edge.
- Support hardware must be ordered separately. See the listings in this section.
- All surfaces have no scoops.

PRODUCT CODE	PRICE LP	SIZE/INCHES			WEIGHT LBS	VOL FT ³
		H	W	D		
CWS2424NSCP	133	1	24	24	16	0.52
CWS2430NSCP	145	1	30	24	20	0.62
CWS2436NSCP	161	1	36	24	23	0.78
CWS2442NSCP	211	1	42	24	28	0.90
CWS2448NSCP	252	1	48	24	31	1.03
CWS2454NSCP	299	1	54	24	35	1.20
CWS2460NSCP	336	1	60	24	39	1.30
CWS2466NSCP	350	1	66	24	43	1.41
CWS2472NSCP	366	1	72	24	47	1.54
CWS2478NSCP	392	1	78	24	51	1.70
CWS2484NSCP	422	1	84	24	55	1.80
CWS2490NSCP	486	1	90	24	58	1.96
CWS2496NSCP	517	1	96	24	63	2.10
CWS3024NSCP	159	1	24	30	20	0.70
CWS3030NSCP	170	1	30	30	25	0.97
CWS3036NSCP	200	1	36	30	30	1.06
CWS3042NSCP	283	1	42	30	34	1.12
CWS3048NSCP	299	1	48	30	39	1.30
CWS3054NSCP	327	1	54	30	44	1.44
CWS3060NSCP	350	1	60	30	49	1.60
CWS3066NSCP	364	1	66	30	54	1.80
CWS3072NSCP	385	1	72	30	59	2.00
CWS3078NSCP	410	1	78	30	64	2.10
CWS3084NSCP	456	1	84	30	69	2.24

CWSP • Worksurface to Span a Post

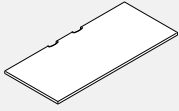

- All tops are thermally fused 1" thick with pilot holes to enable proper alignment with worksurface supports. Wood screws must be used.
- Compile worksurfaces feature a 3mm edge.
- Support hardware must be ordered separately.
- All surfaces longer than 54" have 2 scoops, all others have one.
- Please choose from DWT - Designer White, SIL- Silver or BLK - Black for scoop covers.
- Note: Width and depth dimensions listed include a nominal measurement (3/8") to account for wire management between the worksurface and adjoining panel.

PRODUCT CODE	PRICE LP	SIZE/INCHES			WEIGHT LBS	VOL FT ³
		H	W	D		
CWSP2426P	145	1	26	24	17	0.60
CWSP2432P	161	1	32	24	21	0.70
CWSP2438P	211	1	38	24	25	0.83
CWSP2444P	252	1	44	24	29	1.00
CWSP2450P	299	1	50	24	33	1.10
CWSP2456P	336	1	56	24	37	1.22
CWSP2462P	350	1	62	24	41	1.34
CWSP2468P	366	1	68	24	45	1.47
CWSP2474P	391	1	74	24	49	1.60
CWSP2480P	422	1	80	24	53	1.73
CWSP2486P	456	1	86	24	57	1.90
CWSP3026P	170	1	26	30	22	0.72
CWSP3032P	200	1	32	30	27	0.88
CWSP3038P	283	1	38	30	32	1.04
CWSP3044P	299	1	44	30	37	1.20
CWSP3050P	327	1	50	30	41	1.40
CWSP3056P	350	1	56	30	46	1.51
CWSP3062P	364	1	62	30	51	1.67
CWSP3068P	385	1	68	30	56	1.83
CWSP3074P	410	1	74	30	61	2.00
CWSP3080P	456	1	80	30	66	2.20
CWSP3086P	503	1	86	30	70	2.30

CWVL • Left Curvilinear Worksurface

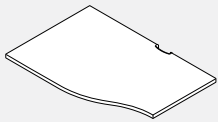

- All tops are thermally fused 1" thick with pilot holes to enable proper alignment with worksurface supports. Wood screws must be used.
- Compile worksurfaces feature a 3mm edge.
- When deepest end equals 24", the opposite depth is 18". When deepest end equals 30", the opposite depth is 24".
- Support hardware must be ordered separately.
- All surfaces longer than 54" have 2 scoops, all others have one.
- Please choose from DWT - Designer White, SIL- Silver or BLK - Black for scoop covers.
- Note: Width and depth dimensions listed include a nominal measurement (3/8") to account for wire management between the worksurface and adjoining panel.

PRODUCT CODE	PRICE LP	SIZE/INCHES			WEIGHT LBS	VOL FT ³
		H	W	D		
CWVL2424P	172	1	24	24	15	0.59
CWVL2430P	182	1	30	24	18	0.65
CWVL2436P	217	1	36	24	22	0.78
CWVL2442P	252	1	42	24	26	0.90
CWVL2448P	289	1	48	24	30	1.03
CWVL2454P	327	1	54	24	34	1.20
CWVL2460P	354	1	60	24	38	1.30
CWVL2466P	392	1	66	24	43	1.49
CWVL2472P	420	1	72	24	47	1.62
CWVL2478P	516	1	78	24	57	2.16
CWVL2484P	749	1	84	24	61	2.33
CWVL3024P	174	1	24	30	19	0.74
CWVL3030P	192	1	30	30	23	0.81
CWVL3036P	229	1	36	30	28	1.00
CWVL3042P	312	1	42	30	33	1.13
CWVL3048P	327	1	48	30	38	1.30
CWVL3054P	364	1	54	30	42	1.44
CWVL3060P	391	1	60	30	47	1.60
CWVL3066P	420	1	66	30	52	1.81
CWVL3072P	451	1	72	30	59	2.01
CWVL3078P	653	1	78	30	72	2.71
CWVL3084P	833	1	84	30	77	2.91

CWVR • Right Curvilinear Worksurface

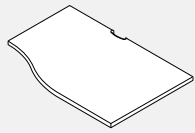

- All tops are thermally fused 1" thick with pilot holes to enable proper alignment with worksurface supports. Wood screws must be used.
- Compile worksurfaces feature a 3mm edge.
- When deepest end equals 24", the opposite depth is 18". When deepest end equals 30", the opposite depth is 24".
- Support hardware must be ordered separately.
- All surfaces longer than 54" have 2 scoops, all others have one.
- Please choose from DWT - Designer White, SIL- Silver or BLK - Black for scoop covers.
- Note: Width and depth dimensions listed include a nominal measurement (3/8") to account for wire management between the worksurface and adjoining panel.

PRODUCT CODE	PRICE LP	SIZE/INCHES			WEIGHT VOL	
		H	W	D	LBS	FT ³
CWVR2424P	172	1	24	24	15	0.59
CWVR2430P	182	1	30	24	18	0.65
CWVR2436P	217	1	36	24	22	0.78
CWVR2442P	252	1	42	24	26	0.90
CWVR2448P	289	1	48	24	30	1.03
CWVR2454P	327	1	54	24	34	1.20
CWVR2460P	354	1	60	24	38	1.30
CWVR2466P	392	1	66	24	43	1.49
CWVR2472P	420	1	72	24	47	1.62
CWVR2478P	516	1	78	24	57	2.16
CWVR2484P	749	1	84	24	61	2.33
CWVR3024P	174	1	24	30	19	0.74
CWVR3030P	192	1	30	30	23	0.81
CWVR3036P	229	1	36	30	28	1.00
CWVR3042P	312	1	42	30	33	1.13
CWVR3048P	327	1	48	30	38	1.30
CWVR3054P	364	1	54	30	42	1.44
CWVR3060P	391	1	60	30	47	1.60
CWVR3066P	420	1	66	30	52	1.81
CWVR3072P	451	1	72	30	59	2.01
CWVR3078P	653	1	78	30	72	2.71
CWVR3084P	833	1	84	30	77	2.91

CWBT • Transition Worksurface

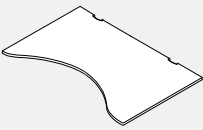

Right Shown

- Support hardware must be ordered separately.
- Please choose from DWT - Designer White, SIL- Silver or BLK - Black for scoop covers.
- Opposing side of the 30" deep surface has a depth of 24"
- Must be specified as right or left handed.

PRODUCT CODE	PRICE LP	SIZE/INCHES			WEIGHT VOL	
		H	W	D	LBS	FT ³
CWBTL302460P	614	1	60	30	55	2.08
CWBTL302466P	678	1	66	30	61	2.29
CWBTL302472P	701	1	72	30	66	2.50
CWBTR302460P	614	1	60	30	55	2.08
CWBTR302466P	678	1	66	30	61	2.29
CWBTR302472P	701	1	72	30	66	2.50

CWCC • Corner Curved Worksurface



- All tops are thermally fused 1" thick with pilot holes to enable proper alignment with worksurface supports. Wood screws must be used.
- Compile worksurfaces feature a 3mm edge.
- Support hardware must be ordered separately.
- Please choose from DWT - Designer White, SIL- Silver or BLK - Black for scoop covers.
- Note: Width and depth dimensions listed include a nominal measurement (3/8") to account for wire management between the worksurface and adjoining panel.
- "WG" indicates diagonal woodgrain.
- "WG" worksurface over 42" cannot be done on the diagonal.

PRODUCT CODE	PRICE LP	SIZE/INCHES			WEIGHT VOL	
		H	W	D	LBS	FT ³
CWCC3618P	397	1	36	36	29	1.20
CWCC3624P	439	1	36	36	32	1.20
CWCC3618WGP	575	1	36	36	29	1.20
CWCC3624WGP	740	1	36	36	32	1.20
CWCC4224P	591	1	42	42	41	1.60
CWCC4230P	607	1	42	42	45	1.60
CWCC4224WGP	846	1	42	42	41	1.60
CWCC4230WGP	963	1	42	42	45	1.60
CWCC4824P	688	1	48	48	50	2.00
CWCC4830P	688	1	48	48	56	2.00

CWCF • Five Sided Worksurface

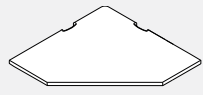

- All tops are thermally fused 1" thick with pilot holes to enable proper alignment with worksurface supports. Wood screws must be used.
- Compile worksurfaces feature a 3mm edge.
- Support hardware must be ordered separately.
- Please choose from DWT - Designer White, SIL- Silver or BLK - Black for scoop covers.
- Note: Width and depth dimensions listed include a nominal measurement (3/8") to account for wire management between the worksurface and adjoining panel.
- "WG" indicates diagonal woodgrain.
- "WG" worksurface over 42" cannot be done on the diagonal.

PRODUCT CODE	PRICE LP	SIZE/INCHES			WEIGHT VOL	
		H	W	D	LBS	FT ³
CWCF3618P	341	1	36	36	29	1.20
CWCF3624P	354	1	36	36	32	1.20
CWCF3618WGP	563	1	36	36	29	1.20
CWCF3624WGP	621	1	36	36	32	1.20
CWCF4224P	503	1	42	42	41	1.60
CWCF4230P	517	1	42	42	45	1.60
CWCF4224WGP	835	1	42	42	41	1.60
CWCF4230WGP	911	1	42	42	45	1.60
CWCF4824P	567	1	48	48	50	2.00
CWCF4830P	596	1	48	48	56	2.00

CWC6 • Corner Curved Worksurface for 60° post

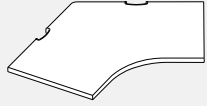

- When specifying wood grain laminate for worksurfaces 42" wide or less, grain will be run diagonally.
- Please add "WG" to the end of the product code and add 50% upcharge to the list price.
- Support hardware must be ordered separately.
- Please choose from DWT - Designer White, SIL- Silver or BLK - Black for scoop covers.

PRODUCT CODE	PRICE LP	SIZE/INCHES			WEIGHT VOL	
		H	W	D	LBS	FT³
CWC62424P	399	1	24	24	21.25	0.47
CWC62430P	709	1	30	24	28.59	0.64
CWC62436P	800	1	36	24	35.94	0.80
CWC62442P	1223	1	42	24	43.28	0.96
CWC62448P	1330	1	48	24	50.63	1.13
CWC63024P	399	1	24	30	23.72	0.53
CWC63030P	709	1	30	30	32.94	0.73
CWC63036P	800	1	36	30	42.16	0.94
CWC63042P	1223	1	42	30	51.38	1.14
CWC63048P	1330	1	48	30	60.60	1.35

CWCEL • Extended Curved Corner Left

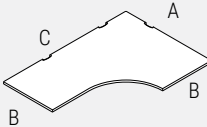

- For 48" wide ("C" dimension) worksurfaces, there are two cable scoops, all others have three.
- All tops are thermally fused 1" thick with pilot holes to enable proper alignment with worksurface supports. Wood screws must be used.
- Compile worksurfaces feature a 3mm edge.
- Support hardware must be ordered separately.
- Please choose from DWT - Designer White, SIL- Silver or BLK - Black for scoop covers.
- Note: Width and depth dimensions listed include a nominal measurement (3/8") to account for wire management between the worksurface and adjoining panel.

NOTE: CWCEL

A	B	C
DEPTH	DEPTH	WIDTH

PRODUCT CODE	PRICE LP	SIZE/INCHES			WEIGHT VOL	
		H	W"C"	D"A"	LBS	FT³
CWCEL362448P	600	1	48	36	43.92	1.25
CWCEL362460P	655	1	60	36	52.79	1.50
CWCEL362466P	721	1	66	36	57.18	1.62
CWCEL362472P	796	1	72	36	61.58	1.75
CWCEL362478P	850	1	78	36	65.98	1.87
CWCEL362484P	917	1	84	36	70.38	2.00
CWCEL422460P	688	1	60	42	57.18	1.63
CWCEL422466P	758	1	66	42	61.58	1.57
CWCEL422472P	835	1	72	42	65.98	1.87
CWCEL422478P	893	1	78	42	70.38	2.00
CWCEL422484P	962	1	84	42	74.78	2.00
CWCEL423060P	775	1	60	42	63.78	1.82
CWCEL423066P	850	1	66	42	69.28	1.96
CWCEL423072P	929	1	72	42	74.78	2.12
CWCEL423078P	996	1	78	42	80.28	2.28
CWCEL423084P	1062	1	84	42	85.78	2.43
CWCEL482460P	786	1	60	48	65.18	1.90
CWCEL482466P	874	1	66	48	71.39	1.92
CWCEL482472P	956	1	72	48	76.18	1.95
CWCEL482478P	1021	1	78	48	74.78	2.20
CWCEL482484P	1083	1	84	48	96.78	3.66
CWCEL483060P	874	1	60	48	68.18	1.93
CWCEL483066P	956	1	66	48	73.68	2.09
CWCEL483072P	1021	1	72	48	79.18	2.25
CWCEL483078P	1083	1	78	48	84.68	2.40
CWCEL483084P	1158	1	84	48	90.18	2.56

CWCER • Extended Curved Corner Right

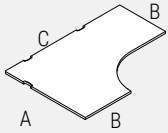

- For 48" wide ("C" dimension) worksurfaces, there are two cable scoops, all others have three.
- All tops are thermally fused 1" thick with pilot holes to enable proper alignment with worksurface supports. Wood screws must be used.
- Compile worksurfaces feature a 3mm edge.
- Support hardware must be ordered separately.
- Please choose from DWT - Designer White, SIL- Silver or BLK - Black for scoop covers.
- Note: Width and depth dimensions listed include a nominal measurement (3/8") to account for wire management between the worksurface and adjoining panel.

NOTE: CWCER

A	B	C
DEPTH	DEPTH	WIDTH

PRODUCT CODE	PRICE LP	SIZE/INCHES			WEIGHT LBS	VOL FT ³
		H	W"C"	D"A"		
CWCER362448P	600	1	48	36	43.92	1.25
CWCER362460P	655	1	60	36	52.79	1.50
CWCER362466P	721	1	66	36	57.18	1.62
CWCER362472P	796	1	72	36	61.58	1.75
CWCER362478P	850	1	78	36	65.98	1.87
CWCER362484P	917	1	84	36	70.38	2.00
CWCER422460P	688	1	60	42	57.18	1.63
CWCER422466P	758	1	66	42	61.58	1.57
CWCER422472P	835	1	72	42	65.98	1.87
CWCER422478P	893	1	78	42	70.38	2.00
CWCER422484P	962	1	84	42	74.78	2.00
CWCER423060P	775	1	60	42	63.78	1.82
CWCER423066P	850	1	66	42	69.28	1.96
CWCER423072P	929	1	72	42	74.78	2.12
CWCER423078P	996	1	78	42	80.28	2.28
CWCER423084P	1062	1	84	42	85.78	2.43
CWCER482460P	786	1	60	48	65.18	1.90
CWCER482466P	874	1	66	48	71.39	1.92
CWCER482472P	956	1	72	48	76.18	1.95
CWCER482478P	1021	1	78	48	74.78	2.20
CWCER482484P	1083	1	84	48	96.78	3.66
CWCER483060P	874	1	60	48	68.18	1.93
CWCER483066P	956	1	66	48	73.68	2.09
CWCER483072P	1021	1	72	48	79.18	2.25
CWCER483078P	1083	1	78	48	84.68	2.40
CWCER483084P	1158	1	84	48	90.18	2.56

CWD • "D" Worksurface

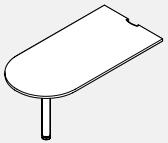

- Includes Monoleg available in standard compile finishes.
- All tops are thermally fused 1" thick with pilot holes to enable proper alignment with worksurface supports. Wood screws must be used.
- Compile worksurfaces feature a 3mm edge.
- Support hardware must be ordered separately. See the listings in this section.
- Please choose from DWT - Designer White, SIL- Silver or BLK - Black for scoop covers.
- Note: Width and depth dimensions listed include a nominal measurement (3/8") to account for wire management between the worksurface and adjoining panel.

PRODUCT CODE	PRICE LP	SIZE/INCHES			WEIGHT LBS	VOL FT ³
		H	W	D		
CWD2442P	569	1	42	24	28.00	0.98
CWD2448P	593	1	48	24	32.00	1.11
CWD2460P	623	1	60	24	40.00	1.36
CWD2472P	661	1	72	24	48.00	1.61
CWD3042P	573	1	42	30	35.00	1.10
CWD3048P	596	1	48	30	39.00	1.37
CWD3060P	665	1	60	30	49.00	1.69
CWD3072P	731	1	72	30	59.00	2.01

CWSW • Straight Wedge Worksurface

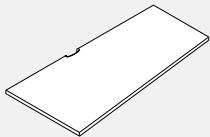

- All tops are thermally fused 1" thick with pilot holes to enable proper alignment with worksurface supports. Wood screws must be used.
- Compile worksurfaces feature a 3mm edge.
- Support hardware must be ordered separately.
- All surfaces longer than 48" have 2 scoops, all others have one.
- Please choose from DWT - Designer White, SIL- Silver or BLK - Black for scoop covers.
- Note: Width and depth dimensions listed include a nominal measurement (3/8") to account for wire management between the worksurface and adjoining panel.

PRODUCT CODE	PRICE LP	SIZE/INCHES			WEIGHT LBS	VOL FT ³
		H	W	D		
CWSW241848P	286	1	48	24	30.00	0.58
CWSW241854P	320	1	54	24	34.00	0.65
CWSW241860P	354	1	60	24	38.00	0.73
CWSW241866P	392	1	66	24	42.00	0.80
CWSW241872P	430	1	72	24	46.00	0.88
CWSW302448P	354	1	48	30	38.00	0.75
CWSW302454P	404	1	54	30	42.00	0.84
CWSW302460P	448	1	60	30	47.00	0.94
CWSW302466P	490	1	66	30	51.00	1.03
CWSW302472P	537	1	72	30	56.00	1.13
CWSW182448P	286	1	48	24	30.00	0.58
CWSW182454P	320	1	54	24	34.00	0.65
CWSW182460P	354	1	60	24	38.00	0.73
CWSW182466P	392	1	66	24	42.00	0.80
CWSW182472P	430	1	72	24	46.00	0.88
CWSW243048P	354	1	48	30	38.00	0.75
CWSW243054P	404	1	54	30	42.00	0.84
CWSW243060P	448	1	60	30	47.00	0.94
CWSW243066P	490	1	66	30	51.00	1.03
CWSW243072P	537	1	72	30	56.00	1.13

CWSW-NSCP • Straight Wedge Worksurface

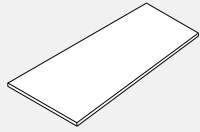

- All tops are thermally fused 1" thick with pilot holes to enable proper alignment with worksurface supports. Wood screws must be used.
- Compile worksurfaces feature a 3mm edge.
- Support hardware must be ordered separately. See the listings in this section.
- All worksurfaces have no scoops.

PRODUCT CODE	PRICE LP	SIZE/INCHES			WEIGHT VOL	
		H	W	D	LBS	FT ³
CWSW241848NSCP	286	1	48	24	30.00	0.58
CWSW241854NSCP	320	1	54	24	34.00	0.65
CWSW241860NSCP	354	1	60	24	38.00	0.73
CWSW241866NSCP	392	1	66	24	42.00	0.80
CWSW241872NSCP	430	1	72	24	46.00	0.88
CWSW302448NSCP	354	1	48	30	38.00	0.75
CWSW302454NSCP	404	1	54	30	42.00	0.84
CWSW302460NSCP	448	1	60	30	47.00	0.94
CWSW302466NSCP	490	1	66	30	51.00	1.03
CWSW302472NSCP	537	1	72	30	56.00	1.13
CWSW182448NSCP	286	1	48	24	30.00	0.58
CWSW182454NSCP	320	1	54	24	34.00	0.65
CWSW182460NSCP	354	1	60	24	38.00	0.73
CWSW182466NSCP	392	1	66	24	42.00	0.80
CWSW182472NSCP	430	1	72	24	46.00	0.88
CWSW243048NSCP	354	1	48	30	38.00	0.75
CWSW243054NSCP	404	1	54	30	42.00	0.84
CWSW243060NSCP	448	1	60	30	47.00	0.94
CWSW243066NSCP	490	1	66	30	51.00	1.03
CWSW243072NSCP	537	1	72	30	56.00	1.13

CWHL/R • Hatchet Worksurface

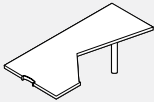

Right Shown

- Wood grain laminate not available on the diagonal.
- Must be specified either left or right.
- Includes Monoleg, available in standard compile finishes.
- Please choose from DWT - Designer White, SIL - Silver or BLK - Black for scoop covers.

PRODUCT CODE	PRICE LP		SIZE/INCHES			WEIGHT VOL	
			H	W	D	LBS	FT ³
CWHL3672P	1079	Left	1	72	36	73.00	2.70
CWHR3672P	1079	Right	1	72	36	73.00	2.70

CWQRL/R • Quarter Round Worksurface



Left Shown

- The worksurface edge running along the panel face is a slightly different length than that of the worksurface end, causing the surface to be handed.
- The user edge abutting the adjacent worksurface runs straight for 2" before starting to curve.

PRODUCT CODE	PRICE LP		SIZE/INCHES			WEIGHT VOL	
			H	W	D	LBS	FT ³
CWQRL2424	200	Left	1	24	24	16	0.52
CWQRL3030	259		1	30	30	25	0.81
CWQRR2424	200	Right	1	24	24	16	0.52
CWQRR3030	259		1	30	30	25	0.81

CWQRC • Quarter Round Corner Worksurface

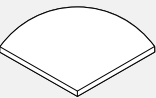

- Wraps around a 90° corner post.
- Putting the adjacent worksurface runs straight for 3" before starting to curve.
- Note: Width and depth dimensions listed include a nominal measurement (3/8") to account for wire management between the worksurface and adjoining panel.

PRODUCT CODE	PRICE LP	SIZE/INCHES			WEIGHT VOL	
		H	W	D	LBS	FT ³
CWQRC2424	235	1	24	24	17.00	0.58
CWQRC3030	289	1	30	30	25.50	0.86

CWT • Straight Transaction Worksurface

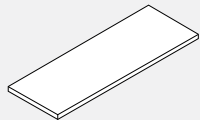

- Support hardware must be ordered separately.
- All tops are thermally fused 1" thick with pilot holes to enable proper alignment with worksurface supports. Wood screws must be used.
- Compile worksurfaces feature a 3mm edge.

PRODUCT CODE	PRICE LP	SIZE/INCHES			WEIGHT VOL	
		H	W	D	LBS	FT ³
CWT1512	57	1	12	15	5	0.22
CWT1518	69	1	18	15	7	0.30
CWT1524	90	1	24	15	10	0.38
CWT1530	106	1	30	15	12	0.46
CWT1536	123	1	36	15	14	0.54
CWT1542	139	1	42	15	17	0.62
CWT1548	157	1	48	15	19	0.70
CWT1554	170	1	54	15	22	0.78
CWT1560	190	1	60	15	24	0.86
CWT1566	204	1	66	15	28	0.94
CWT1572	221	1	72	15	29	1.02
CWT1578	238	1	78	15	31	1.10
CWT1584	253	1	84	15	34	1.18

CWTCL90 • “L” Corner Transaction Surface

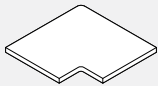

- Used where two panels meet at a 90° angle.
- Support hardware must be ordered separately.

PRODUCT CODE	PRICE	SIZE/INCHES			WEIGHT VOL	
		H	W	D	LBS	FT³
CWTCL90	159	1	20.7	15	12.00	0.75

CW9T • Corner Transaction Surface for 90° Post

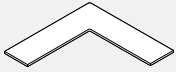

- Used where two panels meet at a 90° angle.
- Support hardware must be ordered separately.

Note: CW9T15 xx Panel Width

PRODUCT CODE	PRICE	SIZE/INCHES			WEIGHT VOL	
		H	W	D	LBS	FT³
CW9T1524	168	1	32.7	15	10.00	0.70
CW9T1530	265	1	38.7	15	12.00	0.75
CW9T1536	373	1	44.7	15	14.00	0.82
CW9T1542	509	1	50.7	15	16.00	0.95
CW9T1548	665	1	56.7	15	18.00	1.00

CHMSL1 • Round Mid Support Leg

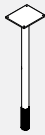

- Available in standard compile standard panel frame colours.
- Includes levelling glide, PVC sleeve and 4.8" x 4.8" plate.
- 1.5" diameter.

PRODUCT CODE	PRICE	LEG DIAMETER	SIZE/INCHES			WEIGHT VOL	
			H	W	D	LBS	FT³
CHMSL1	77	1.5	28	4.8	4.8	8	0.15

CHMSL2 • Square Mid Support Leg

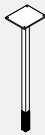

- Available in standard compile standard panel frame colours.
- Includes levelling glide, PVC sleeve and 4.8" x 4.8" plate.

PRODUCT CODE	PRICE	LEG SIZE	SIZE/INCHES			WEIGHT VOL	
			H	W	D	LBS	FT³
CHMSL2	77	1.5	28	4.8	4.8	8	0.15

BHML • Monoleg

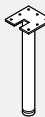

- Provides support for a worksurface.
- Includes an adjustable foot and an attachment plate.
- 3" diameter.
- 1" Height adjustment range.

PRODUCT CODE	PRICE	LEG DIAMETER	SIZE/INCHES			WEIGHT VOL	
			H	W	D	LBS	FT³
BHML03	207	3	28	3	3	8	0.15

CMHCL1 • Round Corner Leg With Leveler



- Provides support for worksurface.
- Includes levelling glide, PVC Sleeve and attachment plate.
- 1.5" diameter.
- Available in standard paint colours.
- Legs can be used in the corner of a single worksurface or be rotated 45 degrees to support the corners of two worksurfaces.

PRODUCT CODE	PRICE	LEG DIAMETER	SIZE/INCHES			WEIGHT VOL	
			H	W	D	LBS	FT³
CMHCL1	108	1.5	28	3	3	8	0.15

CMHCL2 • Square Corner Leg With Leveler



- Provides support for worksurface.
- Includes levelling glide, PVC Sleeve and attachment plate.
- 1.5" diameter.
- Available in standard paint colours.
- Legs can be used in the corner of a single worksurface or be rotated 45 degrees to support the corners of two worksurfaces.

PRODUCT CODE	PRICE	LEG DIAMETER	SIZE/INCHES			WEIGHT VOL	
			H	W	D	LBS	FT³
CMHCL2	108	1.5	28	3	3	8	0.15

CHC • Cantilever



- CHC15 come with wood screws and 3 hole slider, while CHC22 comes with wood screws & 4 hole slider.
- Corresponding panel frame colours only.
- Cantilevers do not share support.

PRODUCT CODE	PRICE	SIZE/INCHES			WEIGHT VOL	
		H	W	D	LBS	FT³
CHC15L	48	5	1.2	15.2	2	0.04
CHC15R	48	5	1.2	15.2	2	0.04
CHC22L	80	8	1.2	21.5	2.6	0.06
CHC22R	80	8	1.2	21.5	2.6	0.06

CHCB2 • Corner and Transaction Bracket

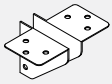

- Attaches the corner of any worksurface to a panel connector.
- Priced and shipped in pairs.
- Available in Standard paint colours.
- Cannot be used off modular.
- Comes with a 2 hole slider.

PRODUCT CODE	PRICE	SIZE/INCHES			WEIGHT LBS	VOL FT ³
		H	W	D		
CHCB2	22	3	1.81	3	0.5	0.02

CH • Worksurface Bracket

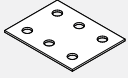

- Black (BLK) only

PRODUCT CODE	PRICE	SIZE/INCHES			WEIGHT LBS	VOL FT ³	
		H	W	D			
CHFB1	21	Flat Bracket	0.1	3	4	0.5	0.007

CHWB • Mid Span Bracket



- Attaches to a segmented panel.
- Must be specified with a worksurface longer than 48".
- Zinc finish only.

PRODUCT CODE	PRICE	SIZE/INCHES			WEIGHT LBS	VOL FT ³
		H	W	D		
CHWB1	13	0.5	2.8	2.1	0.5	0.02

DHPEDB • Pedestal Bracket



- Available in standard paint colours.
- Attaches pedestal to panel and end panel.

PRODUCT CODE	PRICE	SIZE/INCHES			WEIGHT LBS	VOL FT ³
		H	W	D		
DHPEDB	36	8	1	1	0.5	0.001

CHEP • End Panel

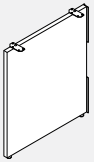

- Supports the worksurface and enhances the stability of connected panels.
- Provides solid support at the end of a run of worksurfaces.
- Finished in thermally-fused laminate.
- End panel height is inclusive of panel glides extended to their fullest height.
- Includes 2 flat brackets (black), 2 pedestal brackets (frame colour) and required screws.
- If wood grains is selected, grain runs vertically.
- Note: May be used as a shared gable between two adjoining worksurfaces.

PRODUCT CODE	PRICE	SIZE/ INCHES			WEIGHT LBS	VOL FT ³
		H	W	D		
CHEP2924	239	28	1	24	17	0.40
CHEP2930	280	28	1	30	21	0.50

CHWSRL01 • Worksurface round Support Leg

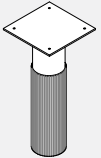

- Provides supports when worksurface overhangs 21" Double Wall Storage or 1.5H 1200 Series Cabinet Storage must have File Top.
- Must be used to support the worksurface in conjunction with panel mounted hardware.
- Contains a levelling glide and PVC sleeve.
- 1.5 diameter round tube.
- Available in BLK (Black) only

PRODUCT CODE	PRICE	SIZE/	INCHES		WEIGHT VOL	
		H	W	D	LBS	FT ³
CHWSRL01	46	4.5	3	3	1.00	0.03

CHMEGR • Metal End Gable Round Leg, Non-handed

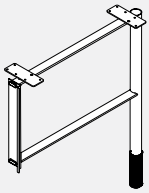

Left Assembly Shown

- **Metal End Gable Leg supports the worksurface and enhances the stability of connected panels.**
- Includes a leveling glide and decorative PVC sleeve to cover the glide.
- Attached to Compile panel connectors. The mounting bracket is universal and attaches with screws to the back of the leg.
- Please specify standard paint finish.
- NOTE: Cannot be used to support worksurfaces side by side. Please use EVHMSRL12 for supporting adjoining worksurfaces.

PRODUCT CODE	PRICE	SIZE/INCHES			WEIGHT LBS	VOL FT ³
		H	W	D		
CHMEGR24	173	29	2	23	6.00	0.73
CHMEGR30	185	29	2	29	6.80	0.90

CHMSRL • Metal Mid Support Round Leg

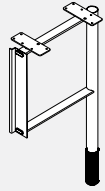

- **Metal Mid Support Leg supports two adjoining worksurfaces and enhances the stability of connected panels.**
- Includes a leveling glide and decorative PVC sleeve to cover the glide.
- Attached to Compile Panels.
- Please specify standard paint finish.

PRODUCT CODE	PRICE	SIZE/INCHES			WEIGHT LBS	VOL FT ³
		H	W	D		
CHMSRL12	149	29	2	11	4.60	0.36

CHMEGS • Metal End Gable Square Leg, Non-handed

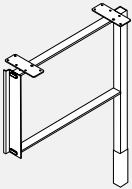

Left Assembly Shown

- **Metal End Gable Leg supports the worksurface and enhances the stability of connected panels.**
- Includes a leveling glide and decorative PVC sleeve to cover the glide.
- Attached to Compile panel connectors. The mounting bracket is universal and attaches with screws to the back of the leg.
- Please specify standard paint finish.
- NOTE: Cannot be used to support worksurfaces side by side. Please use EVHMSSL12 for supporting adjoining worksurfaces.

PRODUCT CODE	PRICE	SIZE/INCHES			WEIGHT LBS	VOL FT ³
		H	W	D		
CHMEGS24	177	29	2	23	6.00	0.73
CHMEGS30	188	29	2	29	6.80	0.90

CHMSSL • Metal Mid Support Square Leg

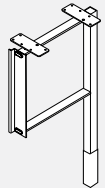

- **Metal Mid Support Leg supports two adjoining worksurfaces and enhances the stability of connected panels.**
- Includes a leveling glide and decorative PVC sleeve to cover the glide.
- Attached to Compile Panels.
- Please specify standard paint finish.

PRODUCT CODE	PRICE	SIZE/INCHES			WEIGHT LBS	VOL FT ³
		H	W	D		
CHMSSL12	152	29	2	11	4.60	0.36

CMHLEG • Compile Bridges Leg Assembly

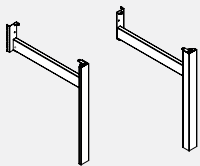

- **Compile Bridges Leg Assembly attaches to a Compile panel for applications which require functionality of Compile panels with an open environment of Bridges tables.**
- One leg with horizontal member connecting to 1" increment slots in panel's vertical frame member. Provides support to panel and panel-connected worksurface at the end of a run; design coordinated with Bridges freestanding tables.
- Supports 24" and 30" deep worksurfaces. By adding 2 CHFB1 flat brackets and 1 CHCB2 corner bracket, a single leg can then support the adjoining worksurface. Leveling glide is standard. No worksurface supporting beams, use panel cantilevers and storage for worksurface support. One aluminum leg with steel structure - specify Left or Right and 24" or 30" deep for corresponding worksurface depths. Panel bracket, dislodgment clip and worksurface hardware included.
- Anodized aluminum leg upcharge \$23.
- Please specify paint finish for support.

PRODUCT CODE	PRICE	SIZE/INCHES			WEIGHT LBS	VOL FT ³
		H	W	D		
CMHLEG24LL	317	28	2.5	24	9	1.25
CMHLEG24RL	317	28	2.5	24	9	1.25
CMHLEG30LL	333	28	2.5	30	11	1.45
CMHLEG30RL	333	28	2.5	30	11	1.45

CMHC • HAT Channel

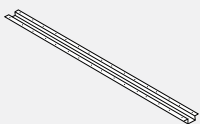

- Support worksurfaces.

PRODUCT CODE	PRICE	SIZE/INCHES			WEIGHT LBS	VOL FT ³
		H	W	D		
CMHC40	58	1.4	40	5	4	0.20
CMHC46	64	1.4	46	5	6	0.22
CMHC52	68	1.4	52	5	7	0.25
CMHC58	78	1.4	58	5	8	0.28
CMHC64	88	1.4	64	5	9	0.31
CMHC70	94	1.4	70	5	10	0.33

CSSL13 • Panel Mount Shelf

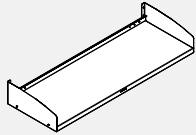

- 13" deep panel-mounted storage shelf with backlip.
- Mounting brackets are included.

PRODUCT CODE	PRICE	SIZE/INCHES			WEIGHT VOL	
		H	W	D	LBS	FT ³
CSSL1324	146	5	24	13	11	1.28
CSSL1330	152	5	30	13	12	1.28
CSSL1336	154	5	36	13	13	1.28
CSSL1342	166	5	42	13	15	1.70
CSSL1348	182	5	48	13	16	1.70
CSSL1354	195	5	54	13	19	2.12
CSSL1360	204	5	60	13	21	2.12

CSOF13 • Flush Front KD Overhead Cabinet

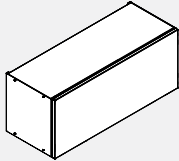

- Door retracts up and over the cabinet.
- Ready for quick assembly on site.
- Quality steel construction.
- Mounting brackets are included.
- 60" unit is reinforced for proper weight distribution.
- Inside dimensions: 12" h. x 12.75" d.
- Lock is not included, please order separately.

PRODUCT CODE	PRICE	SIZE/INCHES			WEIGHT VOL	
		H	W	D	LBS	FT ³
CSOF1324	499	14.5	24	13	27	1.28
CSOF1330	517	14.5	30	13	31	1.28
CSOF1336	573	14.5	36	13	34	1.28
CSOF1342	630	14.5	42	13	38	1.70
CSOF1348	690	14.5	48	13	43	1.70
CSOF1354	747	14.5	54	13	48	2.12
CSOF1360	803	14.5	60	13	53	2.12

CMSLK13 • Lock for CSOF13

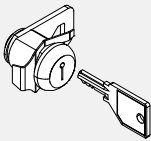

- Lock and key for CSOF13 overhead cabinet.
- Includes one lock assembly and two keys.

PRODUCT CODE	PRICE
CMSLK13	30

CMADA • Panel Mounted Overhead Storage, AODA Compliant

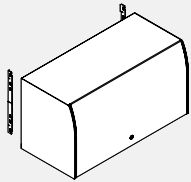

- Panel mounted metal overhead storage with opaque acrylic door. The mechanism lifts the door up and stores it out of the way, above the storage unit.
- Meets CSA B651 Barrier Free Design & AODA (Accessibility for Ontarians with Disabilities Act).
- 16" high units accept standard and A4 binders.
- All shelves are reinforced for proper weight distribution.
- Inside dimensions: 14.25" high x 13.4" deep.
- Shipped partially assembled.
- Unit includes attachment hardware, lock and mounting brackets. Back not included.

PRODUCT CODE	PRICE	SIZE/INCHES			WEIGHT VOL	
		H	W	D	LBS	FT ³
CMADA30PM	839	16	30	14.2	27	5.3
CMADA36PM	906	16	36	14.2	32	6.3
CMADA42PM	970	16	42	14.2	37	7.3
CMADA48PM	1037	16	48	14.2	42	8.3
CMADA54PM	1101	16	54	14.2	47	9.3
CMADA60PM	1167	16	60	14.2	53	10.3

CMDAOH • Center Mount Overhead

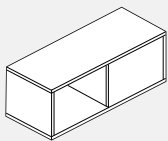

- Inside dimensions 13" high x 13" deep.
- Laminate Overhead.
- Available in standard Compile laminate finishes.
- Top mount on panels.
- Overhead Support Brackets included.

PRODUCT CODE	PRICE	SIZE/INCHES			WEIGHT VOL	
		H	W	D	LBS	FT ³
CMDAOH36	1135	15	36	14.12	10	4.4
CMDAOH42	1222	15	42	14.12	11	5.1
CMDAOH48	1273	15	48	14.12	12	5.8
CMDAOH54	1367	15	54	14.12	13	6.6
CMDAOH60	1415	15	60	14.12	14	7.3

CS93FPxxBFP • 9300 Series Freestanding Box File Pedestal

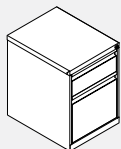

- One box and one file drawer pedestal.
- Freestanding, counterweight included.
- All drawers are locking.
- Box drawer includes pencil tray.

PRODUCT CODE	PRICE	SIZE/INCHES			WEIGHT VOL	
		H	W	D	LBS	FT ³
CS93FP19BFP	524	21.31	15	19	50	5.1
CS93FP23BFP	531	21.31	15	23	55	6.0
CS93FP29BFP	642	21.31	15	29	64	7.5

CS93FPxxBBFP • 9300 Series Freestanding Box Box File Pedestal

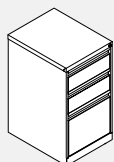

- Two box and one file drawer pedestal.
- Freestanding, counterweight included.
- All drawers are locking.
- Top box drawer includes pencil tray.

PRODUCT CODE	PRICE	SIZE/INCHES			WEIGHT VOL	
		H	W	D	LBS	FT ³
CS93FP19BBFP	568	27.87	15	19	55	6.5
CS93FP23BBFP	578	27.87	15	23	68	7.7
CS93FP29BBFP	692	27.87	15	29	78	9.6

CS93FPxxFFP • 9300 Series Freestanding File File Pedestal

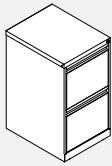

- Two file drawer pedestal.
- Freestanding, counterweight included.
- All drawers are locking.

PRODUCT CODE	PRICE	SIZE / INCHES			WEIGHT VOL	
		H	W	D	LBS	FT ³
CS93FP19FFP	547	27.87	15	19	53	6.5
CS93FP23FFP	554	27.87	15	23	60	7.7
CS93FP29FFP	656	27.87	15	29	70	9.6

CS93WPxxBBFP • 9300 Series Worksurface Supporting Box Box File Pedestal

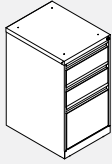

- Two box and one file drawer pedestal.
- Worksurface supporting, includes mounting holes in the top.
- All drawers are locking.
- Top box drawer includes pencil tray.
- Includes filler and brackets.

PRODUCT CODE	PRICE	SIZE / INCHES			WEIGHT VOL	
		H	W	D	LBS	FT ³
CS93WP19BBFP	563	27.87	15	19	55	6.5
CS93WP23BBFP	571	27.87	15	23	68	7.7
CS93WP29BBFP	662	27.87	15	29	78	9.6

CS93WPxxFFP • 9300 Series Worksurface Supporting File File Pedestal

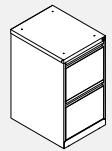

- Two file drawer pedestal.
- Worksurface supporting, includes mounting holes in the top.
- All drawers are locking.
- Includes filler and brackets.

PRODUCT CODE	PRICE	SIZE / INCHES			WEIGHT VOL	
		H	W	D	LBS	FT ³
CS93WP19FFP	540	27.87	15	19	53	6.5
CS93WP23FFP	545	27.87	15	23	60	7.7
CS93WP29FFP	658	27.87	15	29	70	9.6

CS93MPxxBFP • 9300 Series Mobile Box File Pedestal

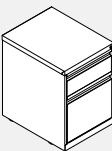

- One box and one file drawer mobile pedestal.
- Casters preinstalled, casters non-locking.
- Counterweight included.
- All drawers locking.
- Box drawer includes pencil tray.
- NOTE: Cannot be used as guest seating.

PRODUCT CODE	PRICE	SIZE / INCHES			WEIGHT VOL	
		H	W	D	LBS	FT ³
CS93MP19BFP	624	27.87	15	19	66	5.2
CS93MP23BFP	646	27.87	15	23	72	6.2
CS93MP29BFP	694	27.87	15	29	92	7.6

CS93MPxxBBFP • 9300 Series Mobile Box Box File Pedestal

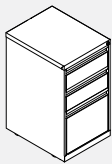

- Two box and one file drawer mobile pedestal.
- Casters preinstalled, casters non-locking.
- Counterweight included.
- All drawers locking.
- Top box drawer includes pencil tray.
- NOTE: Cannot be used as guest seating.

PRODUCT CODE	PRICE	SIZE / INCHES			WEIGHT VOL	
		H	W	D	LBS	FT ³
CS93MP19BBFP	646	27.87	15	19	76	6.5
CS93MP23BBFP	653	27.87	15	23	85	7.7
CS93MP29BBFP	708	27.87	15	29	94	9.6

CS93MPxxFFP • 9300 Series Mobile File File Pedestal

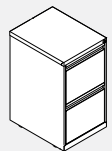

- Two file drawer pedestal.
- Casters preinstalled, casters non-locking.
- Counterweight included.
- All drawers locking.
- NOTE: Cannot be used as guest seating.

PRODUCT CODE	PRICE	SIZE / INCHES			WEIGHT VOL	
		H	W	D	LBS	FT ³
CS93MP19FFP	612	27.87	15	19	73	6.5
CS93MP23FFP	638	27.87	15	23	81	7.7
CS93MP29FFP	706	27.87	15	29	90	9.6

BSPF0BFxxC • Prime Freestanding Box File Pedestal

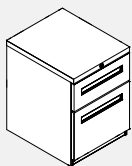

- One box and one file drawer pedestal.
- All drawers are locking.
- Box drawer includes pencil tray.
- For freestanding, to add counterweight (W2 option), add \$50 list.
- For mobile, to add casters and counterweight (W1 option), add \$75 list. Adds 0.5" to height.
- NOTE: Cannot be used as guest seating.

PRODUCT CODE	PRICE	SIZE / INCHES			WEIGHT VOL	
		H	W	D	LBS	FT ³
BSPF0BF18C	571	20.8	15	18	52.4	4.2
BSPF0BF22C	579	20.8	15	22	58.8	5.0
BSPF0BF28C	656	20.8	15	28	68.7	6.3

BSPFSBGxxC • Prime Box Box File Pedestal



- Two box and one file drawer pedestal.
- All drawers are locking.
- Top box drawer includes pencil tray.
- For freestanding, to add counterweight (W2 option), add \$50 list.
- For mobile, to add casters and counterweight (W1 option), add \$75 list. Adds 0.5" to height.
- Top box drawer 4.8"h; middle box drawer 6.4"h; bottom file drawer 13.6"h (interior 12.5"h).
- When worksurface supporting option selected, unit includes pre-drilled top holes for attaching and filler/brackets.

PRODUCT CODE	PRICE	SIZE / INCHES			WEIGHT VOL	
		H	W	D	LBS	FT ³
BSPFSBG18C	637	28	15	18	67.5	5.5
BSPFSBG22C	644	28	15	22	75.0	6.6
BSPFSBG28C	710	28	15	28	86.8	8.3

BSPF0FGxxC • Prime File File Pedestal



- Two file drawer pedestal.
- All drawers are locking.
- For freestanding, to add counterweight (W2 option), add \$50 list.
- For mobile, to add casters and counterweight (W1 option), add \$75 list. Adds 0.5" to height.
- Top file drawer 11.2"h (interior 10.6"h); bottom file drawer 13.6"h (interior 12.5"h).
- When worksurface supporting option selected, unit includes pre-drilled top holes for attaching and filler/brackets.

PRODUCT CODE	PRICE	SIZE / INCHES			WEIGHT VOL	
		H	W	D	LBS	FT ³
BSPF0FG18C	637	28	15	18	67.5	5.5
BSPF0FG22C	644	28	15	22	75.0	6.6
BSPF0FG28C	710	28	15	28	86.8	8.3

BSPW0BFxxC • Prime Mobile Box File Pedestal



- Mobile one box and one file drawer pedestal.
- All drawers are locking.
- 60mm casters.
- Font casters are locking.

PRODUCT CODE	PRICE	SIZE / INCHES			WEIGHT VOL	
		H	W	D	LBS	FT ³
BSPW0BF18C	758	23.3	15	18	73.5	4.6
BSPW0BF22C	763	23.3	15	22	79.1	5.6
BSPW0BF28C	878	23.3	15	28	87.7	7.0

ACCESSORIES

Boulevard, Boulevard System 3, Compile, Diet & Evolve Ergonomic Solutions

Helping Office Inhabitants be Healthy and Efficient

- Ergonomic Computer Accessories
- Energy Efficient Lighting and Power Accessories
- Paper Management Accessories
- Workstation Enhancement Accessories

For use with Boulevard, Boulevard System 3, Compile, Diet and Evolve (unless otherwise specified).

GAKSM01 • Keyboard Support Mechanism

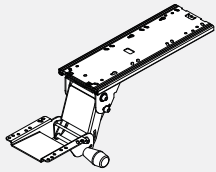

- Soft Touch Knob for simultaneous height & tilt adjustment.
- Spring-assist mechanism helps counter balance weight of keyboard & tray.
- Low-profile design for maximum leg room.
- Includes 21.75" under worksurface Glide Track
- Optional Glide Tracks available at no upcharge:
 - 12" Glide Track add suffix "12" (EXAMPLE GAKSM0112)
 - 18" Glide Track add suffix "18" (EXAMPLE GAKSM0118)
- Available in black only
- To be used with keyboard trays, sold separately.

PRODUCT CODE	PRICE	SIZE/ INCHES			WEIGHT VOL	
		H	W	D	LBS	FT ³
GAKSM01	244	4.3	9	23.8	9.2	0.533

- Height Range 6" (+1.0"/-5.5")
- Soft Touch Knob tilt adjustable range +15°/-15°
- 360° base swivel

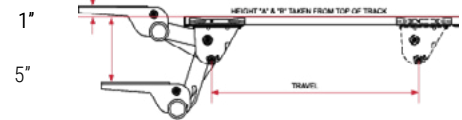
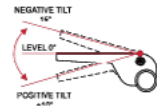

GAKSML • Slim Fit Keyboard Support Mechanism

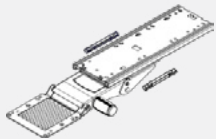

- Height Range 8.88" (+2.38" / - 6.5")
- Tilt Range (+10° / -20°)
- 360° Swivel.
- Meets ANSI/HFES, 100-2007 conformance requirement for height clearance.
- Super slim mechanism design increases clearance under the worksurface.
- Height & depth indicator incorporated together in an intelligently designed dashboard.
- Patented Lift-N-Lock™ height adjustment without knobs or levers automatically locks into position with release of tray for better AODA/Barrier Free compliance.
- Easy access to tilt control knob.
- Designed for disassembly and fully recyclable.
- Includes 21.75" undersurface Glide Track.
- Optional Glide Tracks available:
 - 12" Glide Track add suffix "12" (EXAMPLE GAKSML12)
 - 18" Glide Track add suffix "18" (EXAMPLE GAKSML18)
- "W" Indicated white finish.

PRODUCT CODE	PRICE	SIZE/ INCHES			WEIGHT VOL	
		H	W	D	LBS	FT ³
GAKSML	321	4.75	9.5	24	9	0.627
GAKSMLW	321	4.75	9.5	24	9	0.627

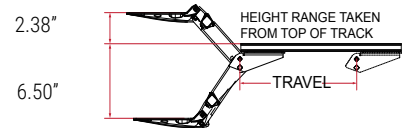
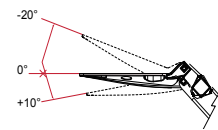

GAKSM02 • Lift-N-Lock Keyboard Support Mechanism

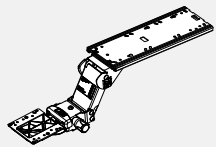

- Patent Pending Height Indicator Gauge allows for precise height setting when used by multiple users, or for returning to optimal height setting after storage.
- Exceeds BIFMA performance standards.

- Includes 21.75" under worksurface Glide Track
- Optional Glide Tracks available at no upcharge:
 - 12" Glide Track add suffix "12" (EXAMPLE GAKSM0212)
 - 18" Glide Track add suffix "18" (EXAMPLE GAKSM0218)
- Available in Black Only
- To be used with keyboard trays, sold separately.

NOTE: Positive Tilt Lockout available. Contact your Customer Service Representative.

- Patented Lift-N-Lock™ height adjustment without knobs or levers automatically locks into position with release of tray for greater. Meets CSA B651 Barrier Free Design & AODA (Accessibility for Ontarians with Disabilities Act).

PRODUCT CODE	PRICE	SIZE/ INCHES			WEIGHT VOL	
		H	W	D	LBS	FT ³
GAKSM02	321	4.3	9	23.8	9.7	0.533

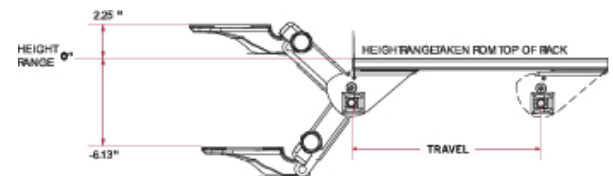

- Height Range 8.38" (+2.25"/-6.13")
- Dial-Tilt Gauge shows precise tilt angles from +10°/-15° positions.
- 360° base swivel

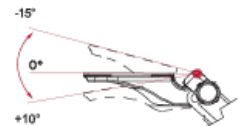

ACCESSORIES

GAKSM03 • Lift-N-Lock Keyboard Support Mechanism

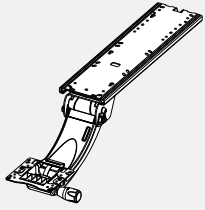

- Patent Pending Height Indicator Gauge allows for precise height setting when used by multiple users, or for returning to optimal height setting after storage.
- Curved neck allows user to be closer to the desk when in standing position.
- Exceeds BIFMA performance standards.

- Includes 21.75" under worksurface Glide Track
- Optional Glide Tracks available at no upcharge:
 - 12" Glide Track add suffix "12" (EXAMPLE GAKSM0312)
 - 18" Glide Track add suffix "18" (EXAMPLE GAKSM0318)

- Available in black only
- To be used with keyboard trays, sold separately.

- **NOTE:** Positive Tilt Lockout available. Contact your Customer Service Representative.
- Maximizes ergonomic support for both seated and standing positions.
- Patented Lift-N-Lock™ height adjustment without knobs or levelers automatically locks into position with release of tray for greater. Meets CSA B651 Barrier Free Design & AODA (Accessibility for Ontarians with Disabilities Act).

PRODUCT CODE	PRICE	SIZE/ INCHES			WEIGHT VOL	
		H	W	D	LBS	FT ³
GAKSM03	519	5.8	9	23.8	11.3	0.719

- Height Range 14.13" (+8.25"/-5.88")
- Dial-Tilt Gauge shows precise tilt angles from +10°/-15° positions.
- 360° base swivel

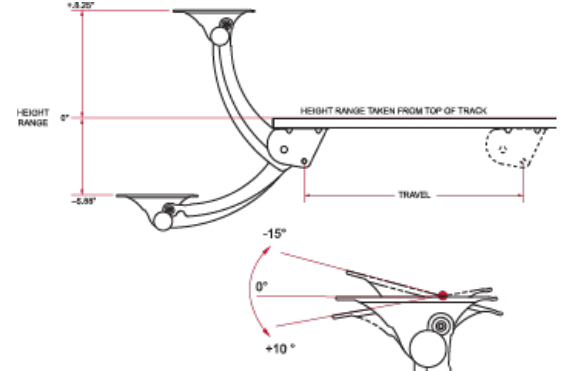

GAKSM05 • Fixed Mount Trackless Keyboard Arm

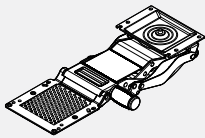

Features:

- Direct Mount, no track required. Ideal solution for Bridges and FreeFit Tables.
- Total height adjustment of 5.73" (-1.25" to -6.98" under the desk surface).
- Enhanced patented Lift-N-Lock™ braking mechanism.
- Soft Touch Knob Dial Tilt with +10° to -15° tilt angles.
- Low profile tray head.
- Separate height and tilt gauges.
- 360° of swivel.
- Optional factory or field installable tilt lockout available.

Benefits:

- Full storage in 9 3/8" undersurface space.
- Exceeds HFES & BIFMA 5" percentile seated keyboarding heights (HFES 22" BIFMA 22.6").
- Easy height adjustment, providing superior lock up and stability with infinite adjustment.
- ADA Compliant tilt adjustment with easily accessible tilt knob.
- Greater knee clearance under desk surface.

PRODUCT CODE	PRICE	SIZE/ INCHES			WEIGHT VOL	
		H	W	D	LBS	FT ³
GAKSM05	300	5	13	9	6	0.317
GAKSM05W	300	5	13	9	6	0.317

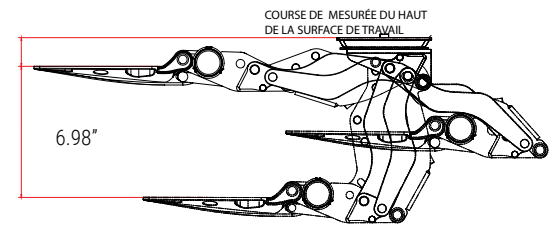

- Allows accurate, repeatable tray placement.
- Allows side to side arm movement.
- Locks out positive tilt for specific ergonomic applications or users preference.
- Provides increased storage where space permits.
- "W" indicated white finish.

GATM01 • Tray with Sliding Mouse Support

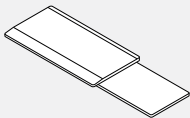

MDF Tray:

- Formed MDF with Textured Finish.
- Foam Anti-skid mat.

Sliding Retractable Mouse Support:

- ABS tray
- Sliding Retractable Mouse Support slides below the tray for left or right mouse positioning.
- Extends 9.91" beyond the end of the Keyboard Tray.
 - 33% recycled content by weight content) and 92.64% recyclable.
- Available in black only

PRODUCT CODE	PRICE	SIZE/ INCHES			WEIGHT VOL	
		H	W	D	LBS	FT ³
GATM01	245	2	21.3	10.5	7	0.259

GATM02 • 27" HDPE Tray with Two Mousing Surfaces

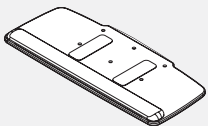

HDPE Tray:

- 1/2" thick High Density Polyethylene with textured finish.
- Includes removable plug-in, gel free foam palm rest.
- Anti-skid strips.

Mousing Surface:

- Keyboard and Mouse can be set up left or right.
- Includes Mouse Fence with Cable Manager.
 - 92.64% recyclable.
- Available in black only

PRODUCT CODE	PRICE	SIZE/ INCHES			WEIGHT VOL	
		H	W	D	LBS	FT ³
GATM02	317	1	27	11	6	0.179

ACCESSORIES

GATM03 • Phenolic Tray with Height Adjustable Mouse Support

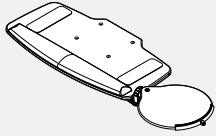

Height Adjustable Mouse Support:

- Ergonomic adjustment of tilt, swivel & height adjustment.
- Can be mounted either left or right.
- Includes mouse fence with cable manager.
- Available in black or white.
- "W" indicates white finish.

PRODUCT CODE	PRICE	SIZE/ INCHES			WEIGHT VOL	
		H	W	D	LBS	FT ³
GATM03	341	2.8	20.5	11	5.8	0.429
GATM03W	341	2.8	20.5	11	5.8	0.429

Phenolic Tray:

- Solid low profile keyboard tray.
- Graphite finish helps hide fingerprints and smudges.
- Includes removable plug-in, gel-free foam palm rest.
- Includes foam Anti-skid strips.

GATM04 • HDPE Tray with Height Adjustable Mouse Support

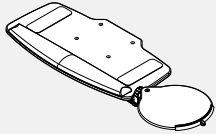

HDPE Tray:

- 1/2" thick High Density Polyethylene with textured finish.
- Includes removable plug-in, gel free foam palm rest.
- 45% recycled content by weight (45% Post Industrial content) and 99.97% recyclable.
- Includes foam anti-skid strips.

PRODUCT CODE	PRICE	SIZE/ INCHES			WEIGHT VOL	
		H	W	D	LBS	FT ³
GATM04	383	3.2	20.5	11	6	0.5

Height Adjustable Mouse Support:

- Ergonomic adjustment of tilt, swivel & height adjustment.
- Can be mounted either left or right.
- Includes mouse fence with cable manager.
 - 92.64% recyclable.
- Available in black only.

GAGTA01 • Glide Tray Adapter (set of 2)

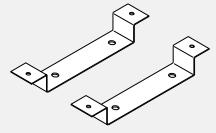

- Attaches to Glide Tracks of all Keyboard Mechanisms and Sliding CPU Holders found within this price list.
- Mounting hardware included.
- Available in black only.
- Not required for use with GAKSM05.

PRODUCT CODE	PRICE	SIZE/ INCHES			WEIGHT VOL	
		H	W	D	LBS	FT ³
GAGTA01	88	2.5	9	2	0.5	0.025

- Accommodates the placement of sliding keyboard mechanisms and CPU holders below the cross beam of a Bridges tables.

Keyboard Combination Chart • Package Codes and Pricing

- "W" at the end of the code designates white keyboard.
- "W" before 2 numbers designates white mechanism.
- "W" in both places in code designates white keyboard and mechanism.

Image	Code	Price	Code	Price	Code	Price	Code	Price
	GATM01			GATM02			GATM03/GATM03W	
	GATM04							
	GAKSP0101	\$492	GAKSP0102	\$560	GAKSP0103 / GAKSP103W	\$586	GAKSP0104	\$626
	GAKSPML01 / GAKSPMLW01	\$564	GAKSPML02 / GAKSPMLW02	\$637	GAKSPML03 / GAKSPML03W / GAKSPMLW03 / GAKSPMLW03W	\$662	GAKSPML04 / GAKSPMLW04	\$702
	GAKSP0201	\$564	GAKSP0202	\$637	GAKSP0203 / GAKSP0203W	\$662	GAKSP0204	\$702
	GAKSP0301	\$762	GAKSP0302	\$832	GAKSP0303 / GAKSP0303W	\$858	GAKSP0304	\$898
	GAKSP0501 / GAKSP0501W	\$547	GAKSP0502 / GAKSP0502W	\$616	GAKSP0503 / GAKSP0503W / GAKSP0503W	\$640	GAKSP0504 / GAKSP0504W	\$681

ACCESSORIES

GACPU01 • Fixed Mount CPU Holder

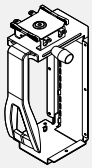

- Fully adjustable clamping mechanism to accept tower CPU's with a wide range of 3.5" to 9.3" and a height range of 12.5" to 22.5".
- Directly mounts to underside of desk surface.
- Soft Touch knob for side clamp adjustment and bayonet lance for vertical height adjustment.
- CPU Holder can also be mounted directly to an upright desk leg surface or wall, via side mounting holes.
- Manufactured from Steel and Engineered Resin,
- providing rugged durability and support.
- Available in Black Only

PRODUCT CODE	PRICE	SIZE/ INCHES			WEIGHT VOL	
		H	W	D	LBS	FT ³
GACPU01	202	18.5	11.7	9.2	9	1.152

GACPU02 • CPU Holder on Glide Track

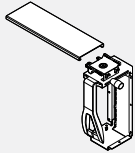

- Accepts tower CPU's with a width range of 3.5" to 9.3" and a height range of 12.5" to 22.5".
- Soft Touch knob for side clamp adjustment and bayonet lance for vertical height adjustment.
- 12" Glide Track mounted and 360° swivel for easy access for rear of CPU
- Manufactured from Steel and Engineered Resin, providing rugged durability and support.
- Available in Black Only

PRODUCT CODE	PRICE	SIZE/ INCHES			WEIGHT VOL	
		H	W	D	LBS	FT ³
GACPU02	290	18.5	11.7	9.2	12.6	1.152

GACPUH • Woof CPU Holder

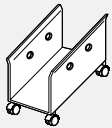

- Provides convenience access to front and back of CPU.
- Expandable width accommodates various sizes of CPU's. Adjusts from 7" to 10".
- Includes 4 locking casters and 4 protective "O" rings.
- Available in Tungsten Only

PRODUCT CODE	PRICE	SIZE/ INCHES			WEIGHT VOL	
		H	W	D	LBS	FT ³
GACPUH	187	11	16	7-10	5	1.0

GAAKS1818 • CRT Corner Plate

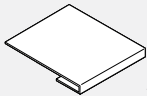

- Converts two abutting worksurfaces in a 90° corner into a 45° angle keyboard worksurface.
- Keyboard mechanism not included.
- Fits worksurfaces 1" to 1.25" thick.
- Available in Panel Frame Finish

PRODUCT CODE	PRICE	SIZE/ INCHES			WEIGHT VOL	
		H	W	D	LBS	FT ³
GAAKS1818	99	1.25	18	18	3.7	0.454

GAMA1 • Single Clamp Mount Monitor Arm

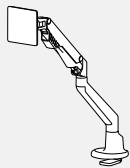

- Finger touch dynamic height adjustment, 12" height range. 4.4 to 19.8 lbs. per monitor loading capacity; accepts screen size 17"-30".
- Maximum monitor width of 34".
- Maximum of 20.5" extension from rear of desk to back of monitor, folds to 4.5".
- Tilt, pan and landscape to portrait rotation; quick release VESA plate, 180 degree lock out.
- Clamp mount and grommet mount options included, accommodates 0.5" to 2" thick tops.
- Accepts mini slide arm GAMS.
- Available in Tungsten (TUN)

PRODUCT CODE	PRICE	SIZE/ INCHES			WEIGHT VOL	
		H	W	D	LBS	FT ³
GAMA1	460	21		5.5	6.6	0.4

GAMA2 • Double Clamp Mount Monitor Arm

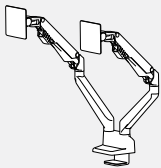

- Finger touch dynamic height adjustment, 12" height range.
- 4.4 to 19.8 lbs. per monitor loading capacity; accepts screen size 17"-30".
- Maximum monitor width of 34".
- Maximum of 20.5" extension from rear of desk to back of monitor, folds to 4.5".
- Tilt, pan and landscape to portrait rotation; quick release VESA plate, 180 degree lock out.
- Clamp mount and grommet mount options included, accommodates 0.5" to 2" thick tops.
- Accepts mini slide arm GAMS.
- Available in Tungsten (TUN)

PRODUCT CODE	PRICE	SIZE/ INCHES			WEIGHT VOL	
		H	W	D	LBS	FT ³
GAMA2	807	21		5.5	12.8	1

GAMS • Mini Slide Monitor Arm

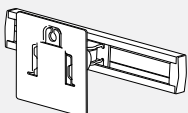

- Works with GAMA1 and GAMA2 monitor arms.
- 9" slide, loading capacity 13.2lbs.
- Quick release VESA plate.
- Available in Tungsten (TUN)

PRODUCT CODE	PRICE	SIZE/ INCHES			WEIGHT VOL	
		H	W	D	LBS	FT ³
GAMS	160	4.5	11	6	3.3	0.3

ACCESSORIES

Monitor Arm Specs

- VESA Mounting plate contains 75 mm & 100 mm mounting configuration
- VESA Plate head is fully adjustable with 180° of tilt, 180° of swivel and 360° of rotation for portrait to landscape viewing
- Keyhole slots in VESA Plate for quick mounting of Display Screen
- Counterbalance spring mechanism does not contain gas cylinders (that are prone to leakage)
- Cable Management provided on arm swivel joints
- Arm components manufactured from 100% recyclable aluminum die cast material, providing stability and durability
- 13" Arm height adjustment on 11" Stainless Steel Pole.
- Pole Support Ring doubles as cable manager.
- 360° of arm swivel around pole.
- Desk Clamp and Grommet mounting options standard on pole applications.
- Monitor arms available in Silver (SIL), Black (BLK), or White (WHT).

GAMCSSDE • Double Extension Monitor Arm for Single Screen

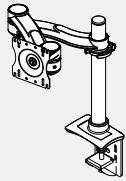

Monitor Arm Single Screen Dual Arm Extension.

- 9 1/2" reach from centre of pole to front of VESA Plate
 - Display Viewing - 180° of tilt, 180° of swivel and 360° of rotation.
 - Quick Mount Versa Plate.
 - 12" Pole Adjustment.
 - 9" Chrome pole adjustment.
- Available in Silver (SIL), Black (BLK) or White (WHT).
- Post is chromed.

PRODUCT CODE	PRICE	SIZE/ INCHES			WEIGHT VOL	
		H	W	D	LBS	FT ³
GAMCSSDE	506	29.3	6.8	9.5	7.5	1.095

GAMCSSDEH • Double Extension with Height Adjustable Monitor Arm for Single Screen

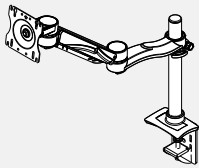

Double extension with height adjustable monitor arm for single screen frees up worksurface space and supports a sit/stand working posture.

- Attaches to the edge of the worksurface or through a grommet.
- Monitor arm adjusts from 3" to 12" from the worksurface.
- Counterbalanced arm provides an additional 13" of height adjustment.
- Monitor connecting bracket swivels 360 degrees and tilts +/- 90 degrees (180 degrees).
- Double extension has 19" of back and forth movement to allow for different focal depths of viewing comfort.
- Built-in cable clips on underside of extension arms and pole base allows organized cable management.
- Available in Silver (SIL), Black (BLK) or White (WHT).
- Post is chromed.

PRODUCT CODE	PRICE	SIZE/ INCHES			WEIGHT VOL	
		H	W	D	LBS	FT ³
GAMCSSDEH	609	29.3	6.8	9.5	8.2	1.095

GAMCDSDE • Monitor Arms for Dual Screens

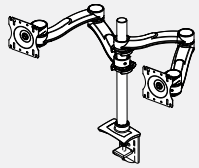

Double extension monitor arms for dual screens frees up worksurface space.

- Used for side-by-side or back-to-back applications.
- Attaches to the edge of the worksurface or through a grommet.
- Monitor arm adjusts from 3" to 12" from the worksurface.
- Monitor connecting extension has 19" of back and forth movement to allow for different focal depths of viewing comfort.
- Max 32" screen width.
- Built-in cable clips on underside of extension arms and pole base allows organized cable management.
- Available in Silver (SIL), Black (BLK) or White (WHT).
- Post is chromed.

PRODUCT CODE	PRICE	SIZE/ INCHES			WEIGHT VOL	
		H	W	D	LBS	FT ³
GAMCDSDE	898	29.3	6.8	9.5	10.7	1.095

GAMCDSDEH • Double Extension with Height Adjustable Monitor Arms for Dual Screens

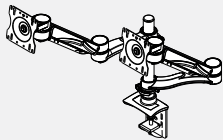

Double extension with height adjustable monitor arms for dual screens frees up the worksurface space and supports a sit/stand working posture.

- Used for side-by-side or back-to-back applications.
- Attaches to the edge of the worksurface or through a grommet.
- Monitor arm adjusts from 3" to 12" from the worksurface.
- Counterbalanced arm provides an additional 13" of height adjustment.
- Monitor connecting bracket swivels 360 degrees and tilts +/- 90 degrees (180 degrees).
- Double extension has 19" of back and forth movement to allow for different focal depths of viewing comfort.
- Built-in cable clips on underside of extension arms and pole base allows organized cable management.
- Max 35" screen width.
- Available in Silver (SIL), Black (BLK) or White (WHT).
- Post is chromed.

PRODUCT CODE	PRICE	SIZE/ INCHES			WEIGHT VOL	
		H	W	D	LBS	FT ³
GAMCDSDEH	1114	29.3	6.8	9.5	12.2	1.095

ACCESSORIES

GAMLDM20 • Single Screen Monitor Arm for 5 to 20lbs

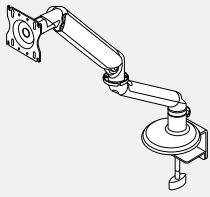

- Comes with clamp and grommet mount, ideal for all desk mounting configurations, minimizing SKU's.
- Adjustable counterbalance cylinder provides smooth 14 1/2" of height adjustment with fingertip control. - counterbalances monitors from 5 lbs. to 20 lbs.
- Double extension arms provide a maximum of 26 3/4" extension from the rear edge of the mounting surface to the VESA Plate for greater monitor adjustment on deep or corner workstations.
- Arms fold back to a minimum dimension of 4 1/2" to provide maximum desk utilization.
- Monitor mounting bracket, with Quick Connect adaptor, contains both 75mm & 100mm hole patterns to match most screen types and compliant with VESA mounting standards.
- Weight gauge provided to allow for quick and easy counterbalance adjustment of the arm prior to installing the screen. Saves time and guesswork especially for multiple arm installations.
- VESA Plate rotates for portrait or landscape viewing with 180° side to side rotation and -90° to +45° tilt for optimal viewing adjustment.
- Die cast aluminum construction provides greater stability and contains high recycled material content with full recyclability.
- Adjustable rotation limiter to restrict arm rotation to 180°, preventing arms from hitting walls.
- Comes with all tools and mounting hardware for quick and easy installation (Tool-free).
- Available in Silver (SIL), Black (BLK) or White (WHT).

PRODUCT CODE	PRICE	SIZE/ INCHES			WEIGHT VOL	
		H	W	D	LBS	FT ³
GAMLDM20	471	38	6	8.5	10.23	1.122

GAMLDM30 • Single Screen Monitor Arm for 10 to 30lbs

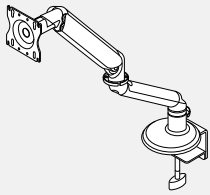

- Comes with clamp and grommet mount, ideal for all desk mounting configurations, minimizing multiple SKU's
- Adjustable counterbalance cylinder provides smooth 14 1/2" of height adjustment with fingertip control - counterbalances monitors from 10 lbs. to 30 lbs.
- Double extension arms provides a maximum of 26.7" extension from the rear edge of the mounting surface to the VESA Plate for greater monitor adjustment on deep or corner workstations
- Arms fold back to a minimum dimension of 4 1/2" to provide maximum desk utilization
- Monitor mounting bracket with Quick Connect adaptor, contains both 75mm & 100mm hole patterns to match most screen types and compliant with VESA mounting standards
- Weight gauge provided to allow for quick and easy counterbalance adjustment of the arm prior to installing the screen.
- Saves time and guesswork especially for multiple arm installations VESA Plate rotates for portrait and landscape viewing with 180° side to side rotation and -90° to +45° tilt for optimal viewing adjustment
- Die cast aluminum construction provides greater stability and contains high recycled material content with full recyclability
- Adjustable rotation limiter to restrict arm rotation to 180°, preventing arms from contacting walls
- Comes with all tools and mounting hardware for quick and easy installation (Tool-free)
- Available in Silver (SIL), Black (BLK) or White (WHT).

PRODUCT CODE	PRICE	SIZE/ INCHES			WEIGHT VOL	
		H	W	D	LBS	FT ³
GAMLDM30	505	38	6	8.5	10.23	1.122

GAMLDM40 • Dual Screen Monitor Arm for combined 15 to 40lbs

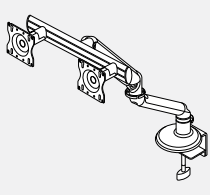

- Comes with clamp and grommet mount, ideal for all desk mounting configurations, minimizing multiple SKU's
- Adjustable counterbalance cylinder provides smooth 14 1/2" of height adjustment with fingertip control and a counterbalance range from 15 lbs. to 40 lbs.
- Double extension arms provide a maximum of 30 3/4" extension from the rear edge of the mounting surface to the VESA Plate for greater monitor adjustment on deep or corner workstations
- Arms fold back to a minimum dimension of 8 3/8" to provide maximum desk utilization
- Monitor mounting bracket with Quick Connect Adaptor, contains both 75mm & 100mm hole patterns to match most screen types and is compliant with VESA mounting standards
- Weight gauge provided to allow for quick and easy counterbalance adjustment of the arm prior to installing the screen. Saves time and guesswork especially for multiple arm installations.
- VESA Plate rotates for portrait and landscape viewing with 180° side to side rotation and -90° to +45° tilt for optimal viewing adjustment
- Die cast aluminum construction provides greater stability and contains high recycled material content with full recyclability
- Adjustable rotation limiter to restrict arm rotation to 180°, preventing arms from contacting walls
- Comes with all tools and mounting hardware for quick and easy installation (Tool-free)
- Available in Silver (SIL), Black (BLK) or White (WHT).

PRODUCT CODE	PRICE	SIZE/ INCHES			WEIGHT VOL	
		H	W	D	LBS	FT ³
GAMLDM40	607	38	6.25	8.5	12.75	1.168

ACCESSORIES

BLVELEDVS • LED Single Arm Lamp



- 7 System watts, 18-fractional LEDs.
- 3500K 250 lumens, 84 CRI.
- Soft touch - instant on, fade to off.
- Infinite dimming 100% down to 15%, last state memory.
- Standard 10 hours turn off (ATO).
- 50,000 hour life LEDs.
- 15 watt, 24 volt wall transformer, 6' cord.
- White (WHT) Silver (SIL) or Black (BLK) - Must specify colour choice.

PRODUCT CODE	PRICE	SIZE/ INCHES			WEIGHT VOL	
		H	W	D	LBS	FT ³
BLVELEDVS	616	8	7	33	7.3	0.98
With Occupancy Sensor						
BLVELEDVSO	920	10	9	35	8.3	1.51

- UL, CUL and CSA compliant, ETL Listed.
- Base not included.

BLVELEDVD • LED Double Arm Lamp

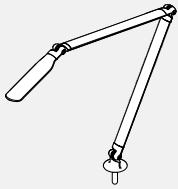

- 7 System watts, 18-fractional LEDs.
- 3500K 250 lumens, 84 CRI.
- Double arm articulation with 20" base to head reaches.
- Soft touch - instant on, fade to off.
- Infinite dimming 100% down to 15%, last state memory.
- Standard 10 hours turn off (ATO).
- 50,000 hour life LEDs.
- 15 watt, 24 volt wall transformer, 6' cord.

PRODUCT CODE	PRICE	SIZE/ INCHES			WEIGHT VOL	
		H	W	D	LBS	FT ³
BLVELEDVD	646	8	7	33	7.6	1.02
With Occupancy Sensor						
BLVELEDVDO	931	10	9	35	8.6	1.57

- White (WHT) Silver (SIL) or Black (BLK) - Must specify colour choice.
- UL, CUL and CSA compliant, ETL Listed.
- Base not included.

BLVELEDRS • LED Single Arm Lamp

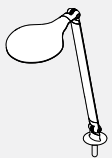

- 7 System watts, 18-fractional LEDs.
- 3500K 250 lumens, 84 CRI.
- Soft touch - instant on, fade to off.
- Infinite dimming 100% down to 15%, last state memory.
- Standard 10 hours turn off (ATO).
- 50,000 hour life LEDs.
- 15 watt, 24 volt wall transformer, 6' cord.
- White (WHT) Silver (SIL) or Black (BLK) - Must specify colour choice.

PRODUCT CODE	PRICE	SIZE/ INCHES			WEIGHT VOL	
		H	W	D	LBS	FT ³
BLVELEDRS	616	8	7	33	7.3	0.98
With Occupancy Sensor						
BLVELEDRSO	920	10	9	35	8.3	1.51

- UL, CUL and CSA compliant, ETL Listed.
- Base not included.

BLVELEDRD • LED Double Arm Lamp

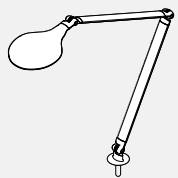

- 7 System watts, 18-fractional LEDs.
- 3500K 250 lumens, 84 CRI.
- Double arm articulation with 20" base to head reaches.
- Soft touch - instant on, fade to off.
- Infinite dimming 100% down to 15%, last state memory.
- Standard 10 hours turn off (ATO).
- 50,000 hour life LEDs.
- 15 watt, 24 volt wall transformer, 6' cord.

PRODUCT CODE	PRICE	SIZE/ INCHES			WEIGHT VOL	
		H	W	D	LBS	FT ³
BLVELEDRD	633	8	7	33	7.6	1.02
With Occupancy Sensor						
BLVELEDRDO	931	10	9	35	8.6	1.57

- White (WHT) Silver (SIL) or Black (BLK) - Must specify colour choice.
- UL, CUL and CSA compliant, ETL Listed.
- Base not included.

Lamp Mounting Options

- White (WHT) Silver (SIL) or Black (BLK) - Must specify colour choice.



Grommet Mount						
PRODUCT CODE	PRICE	SIZE/ INCHES			WEIGHT VOL	
		H	W	D	LBS	FT ³
BLVELEDASM	155	3	6	6	3	0.06



Worksurface Clamp Mount						
PRODUCT CODE	PRICE	SIZE/ INCHES			WEIGHT VOL	
		H	W	D	LBS	FT ³
BLVELEDASCM	155	3	6	6	2	0.04



Slat Wall Mount						
PRODUCT CODE	PRICE	SIZE/ INCHES			WEIGHT VOL	
		H	W	D	LBS	FT ³
BLVELEDASW	155	3	6	6	3	0.06



Panel Mount						
PRODUCT CODE	PRICE	SIZE/ INCHES			WEIGHT VOL	
		H	W	D	LBS	FT ³
BLVELEDAPM	155	3	6	6	3	0.06

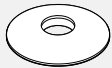

Freestanding Base						
PRODUCT CODE	PRICE	SIZE/ INCHES			WEIGHT VOL	
		H	W	D	LBS	FT ³
BLVELEDAFS	173	4	12	12	6	0.50

ACCESSORIES

GCLEDES • Undercabinet LED Task Light

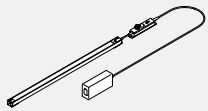

- Linear LED Light.
- Includes light fixture with lens and ON/OFF switch.
- Magnet mounted with adhesive metal plates.
- Plug-in power supply with 72" cord length plus 78" DC cord.

Technical information:

- 4100 K Colour Temperature
- 90 Colour Rendering Index
- 30,000 hrs rated Lifespan
- Total power input per light, 9.0 for 24", 13.5 per 36" and 18.0 for 48"

PRODUCT CODE	PRICE	SIZE/ INCHES			WEIGHT VOL	
		H	W	D	LBS	FT ³
GCLEDES24	164	1	22.9	1	2.5	0.135
GCLEDES36	189	1	33.5	1	2.8	0.161
GCLEDES48	209	1	45.5	1	3.2	0.213

GCLEDES-DCS • Undercabinet Daisychain LED Light

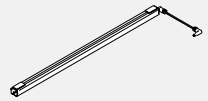

- Undercabinet LED light, 48 inches nominal size, daisychain unit with 1 meter (39 inches) linking cable but no power supply.
- Daisychain units can only be linked up to a total of 48 Watts for all lights on one power supply. This equates to a maximum of 10 feet total nominal length of lights per power supply.

Technical information:

- 4100 K Colour Temperature
- 90 Colour Rendering Index
- 30,000 hrs rated Lifespan
- Total power input per light, 9.0 for 24", 13.5 per 36" and 18.0 for 48"

PRODUCT CODE	PRICE	SIZE/ INCHES			WEIGHT VOL	
		H	W	D	LBS	FT ³
GCLEDES24DSC	134	1	24	1	2.5	0.135
GCLEDES36DSC	157	1	36	1	2.8	0.161
GCLEDES48DSC	178	1	48	1	3.2	0.213

GCLEDESOS • Occupancy Sensor and Dimmer

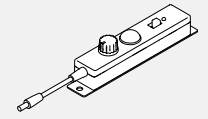

- Inline add-on controller for dimming & occupancy sensor.
- Included, from right to left, a rotary dimmer control, an occupancy sensor and a sensor bypass switch.

PRODUCT CODE	PRICE	SIZE/ INCHES			WEIGHT VOL	
		H	W	D	LBS	FT ³
GCLEDESOS	66	6	2.5	2	0.4	0.500

BEMAE • Mini-Adapt Power Module

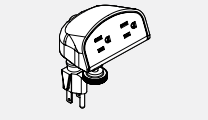

- Accessory Data/Power House.**
- Attaches to scoop at the back of a worksurface.
- BEMAE1 includes 2 simplex outlets, 6' power cord.
- Available in Black Only

PRODUCT CODE	PRICE	SIZE/ INCHES			WEIGHT VOL	
		H	W	D	LBS	FT ³
BEMAE1	193	2	3.625	3	2.5	0.149

BRED50AC • Duo Module with A+C

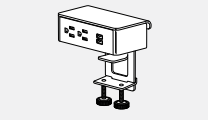

- The Duo power module is completely integrated with a mounting clamp to attach to the edge of a worksurface.**
- Provides two 15 Amp 120 Volt AC Receptacles; 2.4 amp USB-A port and 60 watt USB-C power delivery port.
- 10' long three-prong cord.
- Available in W - White or B - Black as indicated by last letter of model number.

PRODUCT CODE	PRICE	SIZE/ INCHES			WEIGHT VOL	
		H	W	D	LBS	FT ³
BRED50ACW	695	3	5.5	3.2	3	0.2
BRED50ACB	695	3	5.5	3.2	3	0.2

BREDU51AC • Duo Under Module with A+C

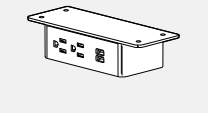

- The Duo under power module comes with a thin flush mounting bracket to attach to the underside of a work surface or above work surface shelves.**
- Provides two 15 Amp 120 Volt AC Receptacles; 2.4 amp USB-A port and 60 watt USB-C power delivery port.
- 10' long three-prong cord.
- Available in W - White or B - Black as indicated by last letter of model number.

PRODUCT CODE	PRICE	SIZE/ INCHES			WEIGHT VOL	
		H	W	D	LBS	FT ³
BREDU51ACW	695	1.8	5.5	2.8	3	0.2
BREDU51ACB	695	1.8	5.5	2.8	3	0.2

Telecom Plates

Note: To be used in conjunction with BPGDPS21 and BPGDPS41.



PRODUCT CODE	PRICE
ABLBB	245



ABLBBB	361
--------	-----



ABLBBBB	476
---------	-----

ACCESSORIES

GCRTMCS401 • Recessed Power Block, 1 Duplex, 1 Data Knock-outs, 1 Power Duplex

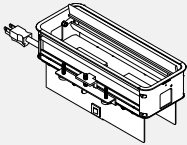

- Single sided recessed power block with 1 regular duplex and 1 data knock-out on top, 1 power duplex on bottom.
- 10 ft power cord with straight plug.
- Telecom plates ordered separately.
- Available in Black - B, Tungsten - T or Designer White - W as indicated by last letter of model number; duplexes always grey.
- Not approved for daisy-chain applications.

PRODUCT CODE	PRICE	SIZE			WEIGHT LBS	VOL FT ³
		H	W	D		
GCRTMCS401B	578	4.86	10.78	4.22	4.3	0.51
GCRTMCS401T	578	4.86	10.78	4.22	4.3	0.51
GCRTMCS401W	578	4.86	10.78	4.22	4.3	0.51

GCRTMCS421 • Recessed Power Block, 1 Power including USB A+C, 1 Data Knock-outs, 1 Power Duplex

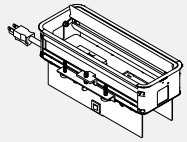

- Single sided recessed power block with 1 power and USB A+C duplex and 1 data knock-out on top, 1 power duplex on bottom.
- USB Type A port charges maximum 2.4 amps at 5V and Type C port charges maximum 3 amps at 5V.
- 10 ft power cord with straight plug.
- Telecom plates ordered separately.
- Available in Black - B, Tungsten - T or Designer White - W as indicated by last letter of model number; duplexes always grey.
- Not approved for daisy-chain applications.

PRODUCT CODE	PRICE	SIZE			WEIGHT LBS	VOL FT ³
		H	W	D		
GCRTMCS421B	759	4.86	10.78	4.22	4.3	0.51
GCRTMCS421T	759	4.86	10.78	4.22	4.3	0.51
GCRTMCS421W	759	4.86	10.78	4.22	4.3	0.51

GCRTMCD602 • Recessed Power Block, 2 Duplex, 2 Data Knock-outs, 1 Power Duplex

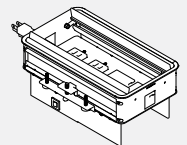

- Double sided recessed power block with 2 regular duplex and 2 data knock-outs on top, 1 power duplex on bottom.
- 10 ft power cord with straight plug.
- Telecom plates ordered separately.
- Available in Black - B, Tungsten - T or Designer White - W as indicated by last letter of model number; duplexes always grey.
- Not approved for daisy-chain applications.

PRODUCT CODE	PRICE	SIZE			WEIGHT LBS	VOL FT ³
		H	W	D		
GCRTMCD602B	660	4.86	10.78	6.22	5.9	0.51
GCRTMCD602T	660	4.86	10.78	6.22	5.9	0.51
GCRTMCD602W	660	4.86	10.78	6.22	5.9	0.51

GCRTMCD622 • Recessed Power Block, 1 Duplex, 1 Power including USB A+C, 2 Data Knock-outs, 1 Power Duplex

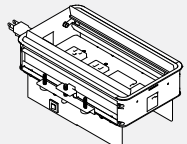

- Double sided recessed power block with 1 regular duplex, 1 power and USB A+C and 2 data knock-outs on top, 1 power duplex on bottom.
- USB Type A port charges maximum 2.4 amps at 5V and Type C port charges maximum 3 amps at 5V.
- 10 ft power cord with straight plug.
- Telecom plates ordered separately.
- Available in Black - B, Tungsten - T or Designer White - W as indicated by last letter of model number; duplexes always grey.
- Not approved for daisy-chain applications.

PRODUCT CODE	PRICE	SIZE			WEIGHT LBS	VOL FT ³
		H	W	D		
GCRTMCD622B	831	4.86	10.78	6.22	6.1	0.51
GCRTMCD622T	831	4.86	10.78	6.22	6.1	0.51
GCRTMCD622W	831	4.86	10.78	6.22	6.1	0.51

GCRTMCD642 • Recessed Power Block, 2 Power including USB A+C, 2 Data Knock-outs, 1 Power Duplex

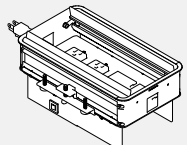

- Double sided recessed power block with 2 power and USB A+C and 2 data knock-outs on top, 1 power duplex on bottom.
- USB Type A port charges maximum 2.4 amps at 5V and Type C port charges maximum 3 amps at 5V.
- 10 ft power cord with straight plug.
- Telecom plates ordered separately.
- Available in Black - B, Tungsten - T or Designer White - W as indicated by last letter of model number; duplexes always grey.
- Not approved for daisy-chain applications.

PRODUCT CODE	PRICE	SIZE			WEIGHT LBS	VOL FT ³
		H	W	D		
GCRTMCD642B	1001	4.86	10.78	6.22	6.3	0.51
GCRTMCD642T	1001	4.86	10.78	6.22	6.3	0.51
GCRTMCD642W	1001	4.86	10.78	6.22	6.3	0.51

DABAR • Power Bar

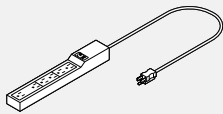

- Power bar with 5 + 1 receptacles (one spaced wide for adapter use), built-in transient voltage surge suppressor and power switch.
- Standard with 10' cord.
- Integrated key hole mounting in the back.
- Rating 15A, 125V, AC 60Hz, 1875W.
- Suppressed voltage rating: 330V peak.

PRODUCT CODE	PRICE	SIZE/ INCHES			WEIGHT LBS	VOL FT ³
		H	W	D		
DABAR	65			12	2	0.02

BABC • Wire Manager



- Attaches to the underside of the worksurface with a peel and stick adhesive that is located on the top of the wire manager. Comes 10 per package.
- Black only

PRODUCT CODE	PRICE	SIZE/ INCHES			WEIGHT LBS	VOL FT ³
		H	W	D		
BABC04	41	2	4	2	2	0.14

BRACS • Cable Snake



- Flexible cable management trough.
- Two pathways within the snake, one for data/communication and one for routing power cables.
- Clear (CLR) available only.

PRODUCT CODE	PRICE	SIZE/ INCHES			WEIGHT LBS	VOL FT ³
		H	W	D		
BRACS	127	30	8		3	0.19
BRACSH	213	49	8		5	0.27

ACCESSORIES

ModPower Power Solution

- Power solutions for flexible spaces. Connect up to four units (in Canada)/six units in the USA from a single infeed with NEMA plug to deliver power and charging ports to the table top. In-surface modules and clamp on modules available.
- Easy to install; code compliant that allows users to optimize any space providing convenient power access. Perfect for training areas, meeting rooms, in-office workstations and more. Units feature tamper-resistant receptacles as well as both USB-A and USB-C charging ports.
- Easy to use connectors that are touch-safe with added latch to prevent unintended separation. Easy push together to connect, and simple press down on latch to disconnect.
- Maximum overall length not to exceed 48.5 feet per infeed. UL listed to UL962A SD, the standard for furniture power distribution units for portable/moveable work space tables.
- Certified to CSA standard C22.2 No. 203-16.
- Will work with Licence, Terina and Bridges Products.

- Surface mounted module ships with a clamp mount that will accommodate any material 1/2" to 1-1/2" thick; additional brackets are also included for screw in mounting options that can accommodate vertical or horizontal positions.
- Modules can be integrated into surfaces but the surface must be specified as a special.

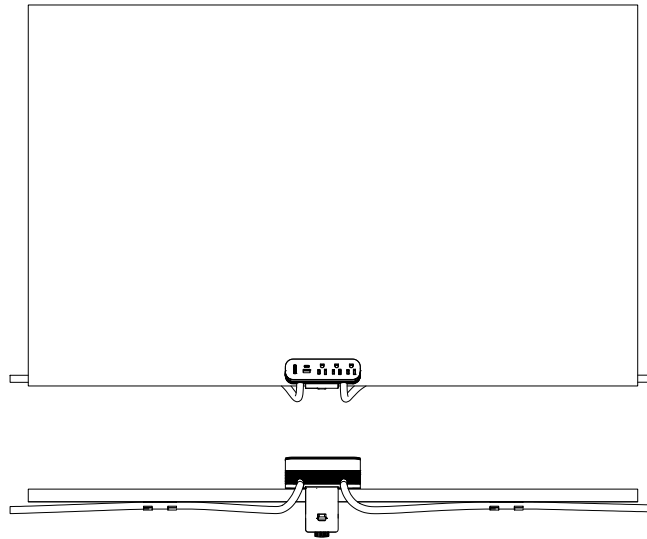
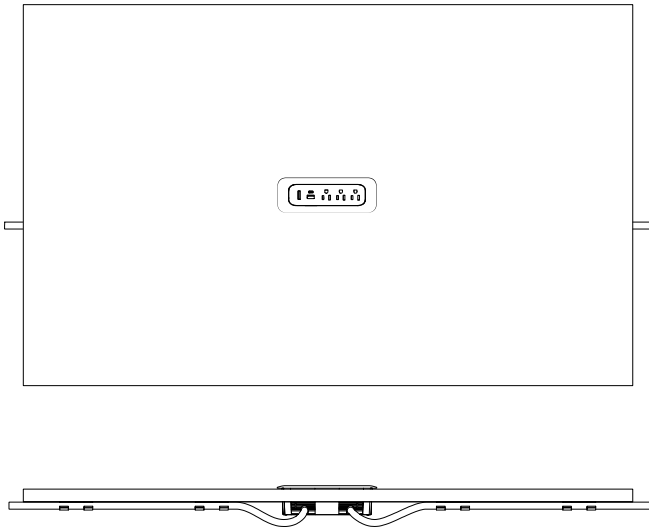
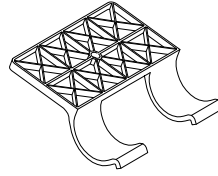

GMDSF10 • ModPower In Surface Starter Unit

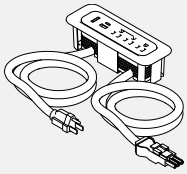

- ModPower starter unit includes one 10' cord with a NEMA plug and one 3' connector cord.
- Unit equipped with three 15A tamper resistant receptacles, one USB-A and one USB-C charging ports and a circuit breaker.
- 4 cable management cord clips included.
- MG at the end of the code indicates a magnesium finish, while WH is a white finish.

PRODUCT CODE	PRICE	DIMENSIONS			WEIGHT		VOL FT ³
		H	W	D	LBS		
GMDSF10MG	597	2.63	7.63	2.63	3.44	1.0	
GMDSF10WH	597	2.63	7.63	2.63	3.44	1.0	

GMDCF3 • ModPower In Surface Middle Unit

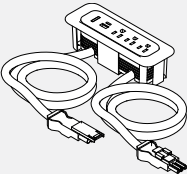

- ModPower middle unit includes two 3' connector cords.
- Unit equipped with three 15A rated 12A tamper resistant receptacles, one USB-A and one USB-C charging ports and a circuit breaker.
- 4 cable management cord clips included.
- MG at the end of the code indicates a magnesium finish, while WH is a white finish.

PRODUCT CODE	PRICE	DIMENSIONS			WEIGHT		VOL FT ³
		H	W	D	LBS		
GMDCF3MG	562	2.63	7.63	2.63	2.44	1.0	
GMDCF3WH	562	2.63	7.63	2.63	2.44	1.0	

GMDEF3 • ModPower In Surface End Unit

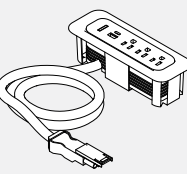

- ModPower end unit includes one 3' connector cord.
- Unit equipped with three 15A rated 12A tamper resistant receptacles, one USB-A and one USB-C charging ports and a circuit breaker.
- 2 cable management cord clips included.
- MG at the end of the code indicates a magnesium finish, while WH is a white finish.

PRODUCT CODE	PRICE	DIMENSIONS			WEIGHT		VOL FT ³
		H	W	D	LBS		
GMDEF3MG	494	2.63	7.63	2.63	1.85	1.0	
GMDEF3WH	494	2.63	7.63	2.63	1.85	1.0	

ACCESSORIES

GMDSA10 • ModPower Starter Mounted Unit

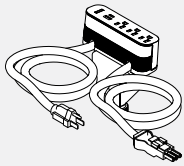

- ModPower starter unit includes one 10' cord with a NEMA plug and one 3' connector cord.
- Unit equipped with three 15A tamper resistant receptacles, one USB-A and one USB-C charging ports and a circuit breaker.
- Includes edge clamp and 3 other mounting methods; and 4 cable management cord clips.
- MG at the end of the code indicates a magnesium finish, while WH is a white finish.

PRODUCT CODE	PRICE	DIMENSIONS			WEIGHT	
		H	W	D	LBS	FT ³
GMDSA10MG	631	2.5	6.13	1.75	4.33	1.0
GMDSA10WH	631	2.5	6.13	1.75	4.33	1.0

GMDCA3 • ModPower Middle Mounted Unit

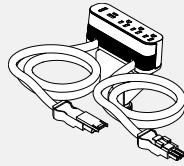

- ModPower middle unit includes two 3' connector cords.
- Unit equipped with three 15A rated 12A tamper resistant receptacles, one USB-A and one USB-C charging ports and a circuit breaker.
- Includes edge clamp and 3 other mounting methods; and 4 cable management cord clips.
- MG at the end of the code indicates a magnesium finish, while WH is a white finish.

PRODUCT CODE	PRICE	DIMENSIONS			WEIGHT	
		H	W	D	LBS	FT ³
GMDCA3MG	597	2.5	6.13	1.75	3.33	1.0
GMDCA3WH	597	2.5	6.13	1.75	3.33	1.0

GMDEA3 • ModPower End Mounted Unit

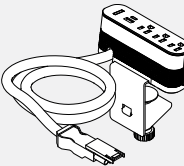

- ModPower end unit includes one 3' connector cord.
- Unit equipped with three 15A rated 12A tamper resistant receptacles, one USB-A and one USB-C charging ports and a circuit breaker.
- Includes edge clamp and 3 other mounting methods; and 2 cable management cord clips.
- MG at the end of the code indicates a magnesium finish, while WH is a white finish.

PRODUCT CODE	PRICE	DIMENSIONS			WEIGHT	
		H	W	D	LBS	FT ³
GMDEA3MG	528	2.5	6.13	1.75	2.75	1.0
GMDEA3WH	528	2.5	6.13	1.75	2.75	1.0

GMDCLIPS • ModPower Management Clips

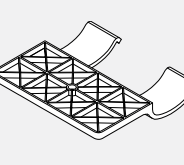

- Includes 10 clips.

PRODUCT CODE	PRICE	DIMENSIONS			WEIGHT	
		H	W	D	LBS	FT ³
GMDCLIPS	102	0.6	2.6	2.5	0.3	0.2

GMDJ36BK • ModPower Interconnecting Jumper

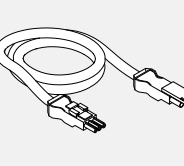

- ModPower interconnecting jumper cord to add an additional 3 feet of cord length between ModPower units.
- Package of 2, each 3 feet with male & female connector.

PRODUCT CODE	PRICE	DIMENSIONS			WEIGHT	
		H	W	D	LBS	FT ³
GMDJ36BK	329		36		1.38	0.9

GMDPC22W • Slim Desktop Power Module, 2 Duplex

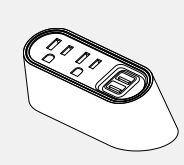

- Desktop power center with two 15A tamper resistant power receptacles, one USB-A and one USB-C (provides 3.1A); 10' power cord.
- Includes three mounting options (i) a screw-in mounting plate for forward facing outlets; or (ii) an under surface mount bracket; or (iii) a clamp mounting kit for 0.5-1.5" thick surfaces.
- Gloss white body with grey face.

PRODUCT CODE	PRICE	DIMENSIONS			WEIGHT	
		H	W	D	LBS	FT ³
GMDPC22W	449	2.25	4.88	2.25	2.5	0.5

GMDPC32W • Slim Desktop Power Module, 3 Duplex

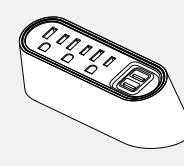

- Desktop power center with three 15A tamper resistant power receptacles, one USB-A and one USB-C (provides 3.1A); 10' power cord.
- Includes three mounting options (i) a screw-in mounting plate for forward facing outlets; or (ii) an under surface mount bracket; or (iii) a clamp mounting kit for 0.5-1.5" thick surfaces.
- Gloss white body with grey face.

PRODUCT CODE	PRICE	DIMENSIONS			WEIGHT	
		H	W	D	LBS	FT ³
GMDPC32W	586	2.25	6.00	2.25	2.6	0.5

ACCESSORIES

BAVC • Vertical Wire Channel



- PVC extrusion attaches to panel vertical to provide enclosure for a power or light cord.
- Available in 16" and 32" lengths, six per package.
- Can be cut to required lengths on site.
- Panel frame finish

PRODUCT CODE	PRICE	SIZE/	INCHES		WEIGHT VOL	
		H	W	D	LBS	FT ³
BAVC016	38		16		0.5	0.018
BAVC032	80		32		1.0	0.036

VVCM • Wire Manager

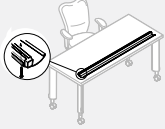

- Replacement wire manager can be added to Viceversa tables. Wire manager neatly organizes and stores electrical and communication cables.
- Two lengths, 46" for tops 60" and under, 58" for tops 72".
- Mounts below surface via threaded metal inserts.
- Integrated steel reinforcement bar.
- Not required on oval, 1/2 ellipse, 1/2 moon, square or round table.

PRODUCT CODE	PRICE	SIZE/	INCHES			WEIGHT VOL	
		H	D	W	LBS	FT ³	
VVCM43	143	3	5	46	8	0.67	
VVCM55	169	3	5	58	9	0.85	

BAR • Panel Mounted Slotted Accessory Rail for Boulevard

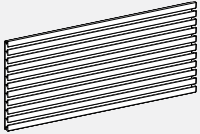

- Includes 10 horizontal slats for hanging capacity.
- Includes mousing hardware.
- Panel frame finish

Hangs on standard Boulevard panels and accepts standard accessories.

PRODUCT CODE	PRICE	SIZE/	INCHES			WEIGHT VOL	
		H	W	D	LBS	FT ³	
BAR18	161	10.6	18	0.5	3	0.12	
BAR24	176	10.6	24	0.5	4	0.17	
BAR30	195	10.6	30	0.5	5	0.22	
BAR36	211	10.6	36	0.5	6	0.26	
BAR42	231	10.6	42	0.5	7	0.31	
BAR48	246	10.6	48	0.5	8	0.35	
BAR54	262	10.6	54	0.5	9	0.43	
BAR60	280	10.6	60	0.5	10	0.49	

BALB • Panel Mounted Load Bar for Boulevard

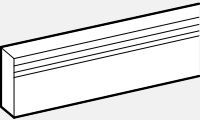

- Can be panel mounted or wall mounted on rail (BHV01 or BHV02).
- Includes mousing brackets and end caps.
- Panel frame finish

PRODUCT CODE	PRICE	SIZE/	INCHES			WEIGHT VOL	
		H	W	D	LBS	FT ³	
BALB18	122	3.5	18	0.75	2	0.031	
BALB24	133	3.5	24	0.75	2	0.038	
BALB30	146	3.5	30	0.75	3	0.048	
BALB36	162	3.5	36	0.75	3	0.057	
BALB42	187	3.5	42	0.75	4	0.067	
BALB48	213	3.5	48	0.75	4	0.076	
BALB54	234	3.5	54	0.75	5	0.086	
BALB60	247	3.5	60	0.75	5	0.096	

BADLB • Panel Mounted Accessory Rail for Boulevard

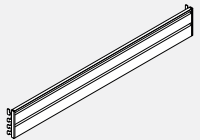

- Enables accessory items to be hung from a panel.
- Includes end caps and mounting brackets.

PRODUCT CODE	PRICE	SIZE/	INCHES			WEIGHT VOL	
		H	W	D	LBS	FT ³	
BADLB18	195	4.23	18	1.53	2.34	0.07	
BADLB24	205	4.23	24	1.53	2.88	0.09	
BADLB30	217	4.23	30	1.53	3.42	0.11	
BADLB36	231	4.23	36	1.53	3.97	0.13	
BADLB42	240	4.23	42	1.53	4.51	0.16	
BADLB48	253	4.23	48	1.53	5.05	0.18	
BADLB54	265	4.23	54	1.53	5.59	0.20	
BADLB60	275	4.23	60	1.53	6.13	0.22	

BABB01 • Binder Bin

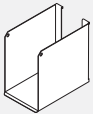

- Load bar/accessory rail mounted metal binder bin.
- Panel frame finish

PRODUCT CODE	PRICE	SIZE/	INCHES			WEIGHT VOL	
		H	W	D	LBS	FT ³	
BABB01	58	9	5.75	9.25	1.85	0.21	

BAFS01 • Flip Sorter



- Load bar/accessory rail mounted metal flip sorter. Comes with chrome wire.
- Panel frame finish

PRODUCT CODE	PRICE	SIZE/	INCHES			WEIGHT VOL	
		H	W	D	LBS	FT ³	
BAFS01	40	9	3	9	0.6	0.14	

ACCESSORIES

BASS01 • Slant Sorter

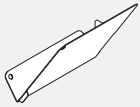

Right Shown

- Load bar/accessory rail mounted metal slant sorter.
- Panel frame finish

PRODUCT CODE	PRICE	SIZE/ INCHES			WEIGHT VOL	
		H	W	D	LBS	FT ³
BASS01R	35	9.25	2.75	9	1	0.28
BASS01L	35	9.25	2.75	9	1	0.28

BALT • Letter Tray/Legal Tray

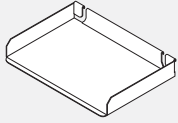

- Load bar/accessory rail mounted metal letter or legal tray.
- Panel frame finish

PRODUCT CODE	PRICE	SIZE/ INCHES			WEIGHT VOL	
		H	W	D	LBS	FT ³
BALT01	43	1.75	12	8.75	0.5	0.15
BALT01LGL	58	1.75	14.7	8.75	0.5	0.15

BAMB01 • Media Bin

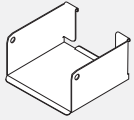

- Load bar/accessory rail mounted metal media bin.
- Panel frame finish

PRODUCT CODE	PRICE	SIZE/ INCHES			WEIGHT VOL	
		H	W	D	LBS	FT ³
BAMB01	43	3	5.75	5.25	0.8	0.05

BAUT01 • Utility Tray

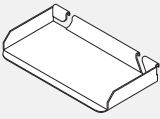

- Load bar/accessory rail mounted metal utility tray.
- Panel frame finish

PRODUCT CODE	PRICE	SIZE/ INCHES			WEIGHT VOL	
		H	W	D	LBS	FT ³
BAUT01	30	1	7.5	4	0.5	0.02

BAPP01 • Mail Box

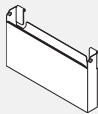

- Freestanding unit or load bar/accessory rail mounted.
- Panel frame finish

PRODUCT CODE	PRICE	SIZE/ INCHES			WEIGHT VOL	
		H	W	D	LBS	FT ³
BAPP01	72	7	12	1.75	2	0.25

BATH01 • Telephone Holder

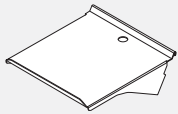

- Load bar/rail mounted telephone holder.
- Panel frame finish

PRODUCT CODE	PRICE	SIZE/ INCHES			WEIGHT VOL	
		H	W	D	LBS	FT ³
BATH01	68	2	8	10	2	0.26

BAPD • Pencil Drawer

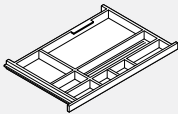

- Provides accommodation for writing instruments and small items at the workspace.
- Attaches to the underside of worksurface with drawer slides.
- Available in Black ABS Only

PRODUCT CODE	PRICE	SIZE/ INCHES			WEIGHT VOL	
		H	W	D	LBS	FT ³
BAPD2015	133	1.5	22.5	17.75	2	0.300

BAHO • Coat Hook

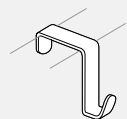

- Over the panel mounted coat hook for Boulevard 1 panels only. Priced six per package.
- Panel Frame Finish

PRODUCT CODE	PRICE	SIZE/ INCHES			WEIGHT VOL	
		H	W	D	LBS	FT ³
BAHO3080	63	3	1	3	0.2	0.001

BAHB3CH • Coat Hook for System 3

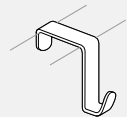

- Over the panel mounted coat hook for Boulevard, System 3 panels or Boulevard 1 panels with top trim. Priced six per package.
- Panel Frame Finish

PRODUCT CODE	PRICE	SIZE/ INCHES			WEIGHT VOL	
		H	W	D	LBS	FT ³
BAHB3CH	83	3	1	3	0.2	0.001

DAHOCH • Coat Hook for Diet

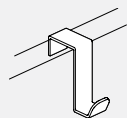

- Panel mounted coat hook Diet Panels.
- Panel Frame Finish

PRODUCT CODE	PRICE	SIZE/ INCHES			WEIGHT VOL	
		H	W	D	LBS	FT ³
DAHOCH	29	3	0.75	3	0.2	0.001

ACCESSORIES

BPNP • Boulevard Name Plate

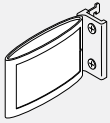

- Name plate attaches to 1" increment slots of Boulevard. It can be set either as a single-sided (parallel to panel surface) or double-sided (perpendicular to panel surface - for aisle applications, displaying name on both sides).
- Injection molded frame and die-cast base with black rubberized finish. Steel bracket and fasteners included.
- Includes two slide-in name cards.

PRODUCT CODE	PRICE	SIZE/ INCHES			WEIGHT VOL	
		H	W	D	LBS	FT ³
BPNP01	82	3.3	5.3	1.25	0.3	0.013

DPNP01 • Diet Name Plate

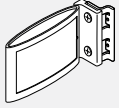

- Name plate can be set either as a single-sided (parallel to panel surface) or double-sided (perpendicular to panel surface - for aisle applications, displaying name on both sides).
- Injection molded frame and die-cast base with black rubberized finish. Steel bracket and fasteners included.
- Includes two slide-in name cards.

PRODUCT CODE	PRICE	SIZE/ INCHES			WEIGHT VOL	
		H	W	D	LBS	FT ³
DPNP01	82	3.3	5.3	1.25	0.3	0.013

BHTPO1 • Bracket to connect Licence Towers to Boulevard Panels

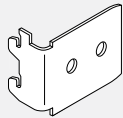

- Panel Frame Finish

PRODUCT CODE	PRICE	SIZE/ INCHES			WEIGHT VOL	
		H	W	D	LBS	FT ³
BHTPO1	64	2	2.5	1	2	0.05

BATB • Fabric Tackboard for Boulevard

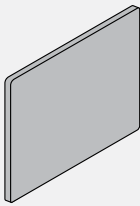

- To provide a tackable surface for notes and memos in a work area. Panel mounted.
- Includes mounting brackets.
- Class "A" Fire Rated Fabric.

PRODUCT CODE	PRICE		SIZE/ INCHES			WEIGHT VOL	
	GR1	GR2	H	W	D	LBS	FT ³
BATB2430	298	312	24	30		3	0.416
BATB2436	340	352	24	36		4	0.500
BATB2442	388	404	24	42		4	0.583
BATB2448	433	462	24	48		5	0.666
BATB2454	478	509	24	54		5	0.750
BATB2460	524	555	24	60		6	0.833
BATB2472	636	678	24	72		6	0.999

BAWB • Write Board for Boulevard

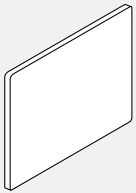

- To provide a writing surface in a work area. Panel mounted.
- Includes mounting brackets.
- Black Trim Only

PRODUCT CODE	PRICE	SIZE/ INCHES			WEIGHT VOL	
		H	W	D	LBS	FT ³
BAWB2436	350	24	36		13	0.500
BAWB2442	391	24	42		15	0.583
BAWB2448	454	24	48		18	0.666

BAMT12 • Marker Tray

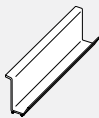

- Marker tray intended for BATB and BAWB only.

PRODUCT CODE	PRICE	SIZE/ INCHES			WEIGHT VOL	
		H	W	D	LBS	FT ³
BAMT12	16		12		0.5	0.01

BATP • Touch Up Paint Kit



- Paint to match panel frame colours for easy touch ups. 1/2oz. (15ml) bottle

PRODUCT CODE	PRICE	SIZE/ INCHES			WEIGHT VOL	
		H	W	D	LBS	FT ³
BATP91	41				0.41	0.1

ACCESSORIES

CATB • Tackboard for Compile

- Mounting brackets included.

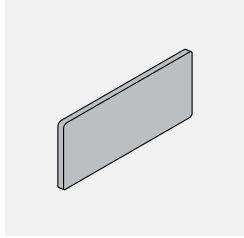

PRODUCT CODE	PRICE		SIZE/INCHES			WEIGHT VOL	
	GR1	GR2	H	W	D	LBS	FT ³
CATB1024	192	200	10	24	1	1	0.175
CATB1030	201	212	10	30	1	1	0.208
CATB1036	221	236	10	36	1	2	0.250
CATB1042	245	260	10	42	1	2	0.291
CATB1048	270	284	10	48	1	3	0.333
CATB1054	297	317	10	54	1	3	0.370
CATB1060	317	340	10	60	1	4	0.415
CATB2124	276	284	21	24	1	2	0.340
CATB2130	298	312	21	30	1	2	0.406
CATB2136	340	352	21	36	1	3	0.490
CATB2142	388	404	21	42	1	3	0.573
CATB2148	433	462	21	48	1	4	0.656
CATB2154	478	509	21	54	1	4	0.740
CATB2160	524	555	21	60	1	5	0.823
CATB2424	276	284	24	24	1	3	0.350
CATB2430	298	312	24	30	1	3	0.416
CATB2436	340	352	24	36	1	4	0.500
CATB2442	388	404	24	42	1	4	0.583
CATB2448	433	462	24	48	1	5	0.666
CATB2454	478	509	24	54	1	5	0.750
CATB2460	524	555	24	60	1	6	0.833

CAWB • Whiteboard for Compile

- Mounting brackets included.

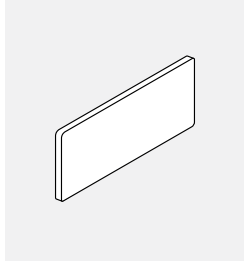

PRODUCT CODE	PRICE	SIZE/INCHES			WEIGHT VOL	
		H	W	D	LBS	FT ³
CAWB1024	168	10	24	0.625	5	0.210
CAWB1036	190	10	36	0.625	6	0.394
CAWB1042	211	10	42	0.625	7	0.470
CAWB1048	240	10	48	0.625	8	0.540
CAWB2124	279	21	24	0.625	11	0.400
CAWB2136	333	21	36	0.625	12	0.485
CAWB2142	372	21	42	0.625	14	0.564
CAWB2148	433	21	48	0.625	17	0.621
CAWB2424	279	24	24	0.625	12	0.422
CAWB2436	333	24	36	0.625	13	0.500
CAWB2442	372	24	42	0.625	15	0.583
CAWB2448	433	24	48	0.625	18	0.666

CALB • Load Bar for Compile

- Available in standard panel frame colours.
- Mounting brackets and clear end caps included.
- Optional - Load Bar can connect to each other to create a "Slat Wall".

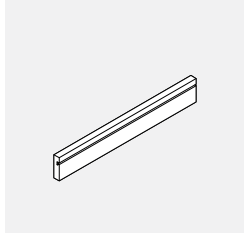

PRODUCT CODE	PRICE	SIZE/INCHES			WEIGHT VOL	
		H	W	D	LBS	FT ³
CALB24	133	2.25	24	1	2	0.083
CALB30	146	2.25	30	1	3	0.048
CALB36	161	2.25	36	1	3	0.057
CALB42	187	2.25	42	1	4	0.067
CALB48	213	2.25	48	1	4	0.076
CALB54	234	2.25	54	1	5	0.086
CALB60	247	2.25	60	1	5	0.096

CMECC • Cable Cover for Compile

- Available in standard panel frame colours.
- Comes 6 per package

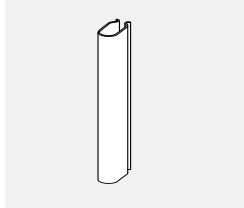

PRODUCT CODE	PRICE	SIZE/INCHES			WEIGHT VOL	
		H	W	D	LBS	FT ³
CMECC21	31	21	0.5	1	0.5	0.018
CMECC36	56	36	0.5	1	1.0	0.036

CMCH01 • Coat Hook for Compile

- Coat hook for Compile panels.

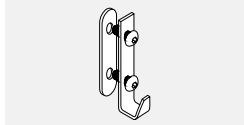

PRODUCT CODE	PRICE	SIZE/	INCHES		WEIGHT VOL	
		H	W	D	LBS	FT ³
CMCH01	43	5.5	0.65	1	0.06	0.001

ENVIRONMENTAL COMMITMENT

Evolve Systems-Protecting the Environment for Future Generations

- Our environmental success story began with the challenge to create an office system that would meet today's business requirements while maintaining a firm commitment to save and protect the environment.
- Sustainability became a part of the creative focus and development of Evolve that incorporates the latest technology and design features to provide excellent performance at a competitive price.
- As government and industry environment ratings such as LEED become more prevalent, Evolve offers designers and architects functional, attractive, and economical office designs that meet these standards.
- Evolve is a leader in reducing waste and recycling materials in the manufacture of its products. We make extensive use of recycled plastic and wood waste from other Global factories.
- Evolve is committed to exercise diligence in the continuous improvement of our environmental systems, the prevention of pollution, and to comply with both the spirit and the letter of all relevant environmental legislation.
- Evolve panels are 100% recyclable at the end of their lifespan. Nothing from an Evolve panel needs to end up in a landfill.

Evolve Systems-Product Information

- Evolve offers fabrics that are made from 100% recycled polyester, which means less waste going to landfills, reduced demand for petroleum products, and fewer environmental impacts from the processing of petroleum products into polyester.
- Evolve has developed a panel interior made from 100% recycled wood and polypropylene. Through innovative design and technology, Evolve utilizes waste that would have normally been sent to landfill.
- Evolve panels are insulated with a mineral fibre insulation made from slag (an inert steel by-product) and basalt rock. This material's high density provides maximum sound absorption to reduce noise in the work environment. Mineral fibre insulation is fire resistant, water repellent and will not support the growth of fungi or mildew.

Evolve Systems-Special Product

- When ordering specials, copies of the Special Quote Form (SQ's) must be submitted with the order to ensure accuracy of the special product.

PANELS

- Panel Fabric modules consist of Module Frames, Module Interiors and Fabric Skins. **Module Construction**

- Module Frames feature a combination of 100% recycled PVC horizontal extrusions and unique, molded vertical ends made from equal parts of 100% recycled polypropylene and 100% recycled wood (from Global's factory waste).
- Module Interiors feature honeycomb made from 75% recycled kraft paper and acoustical mineral board derived from slag (inert steel by-product) and volcanic material.

Fabric

- Fabric offerings include selections woven with 100% recycled yarn.

Panel Frame

- Panel Frame is made of cold rolled steel which has a recycled content of 25%. **Metal Components/Raceway Finish**
- All metal components are painted with environmentally friendly epoxy powder.
- Raceway interiors are coated with recycled epoxy powder.

Panel Options

- Factory installed Panel Modules are available in 6", 12", 18" and 24" heights and a variety of options including: Semi-Tackable Fabric Acoustic, Glass, Open, Slatwall, Laminate and Whiteboard Modules.

- Standard Fabric Acoustic Panels come in a variety of heights: 30", 42", 54" and 66". Monolithic Panels are available in 42", 48", 54".
- Panel Extension Modules attach to the top of the base structural panels. These are offered in 6", 12", 18" and 24" heights and can be stacked one on top of the other to create a visually continuous panel in excess of 14'-0" high.
- Panels can be modified on-site by swapping fabric modules for glazed, open, laminate or whiteboard modules at any time after the initial installation. Panels can also be altered in height by replacing the vertical liners (panel sides) and adding or subtracting modules as required.
- Panel widths come in 8 sizes including: 18", 24", 30", 36", 42", 48", 54" and 60".
- All Fabric Modules are semi-tackable.
- One sided and two sided whiteboard modules are available.
- Panels conform to CGSB and ANSI/BIFMA standards.
- Evolve panels carry an acoustical rating of .65 NRC and 20 STC.
- Rigid, steel panel frame is 2 7/8" thick.
- Levelling glides extend 2 1/2".

VOICE/DATA AND ELECTRIC POWER

- Voice/data cables can be laid in at both the base and the top of the panel.
- 8 wire, 4 circuit electrical capability, 2 utility + 2 dedicated circuits, each with 10 gauge (oversized) neutrals. All circuits are 20 amps (15 CSA).
- Additional 8 wire features. No tools required.
- Both power and data is available at desk height.
- Raceway Cover opening sizes conform to the ANSI/TIA/EIA Furniture Opening Standard of 1.37 x 2.68.
- Panels and electrical components are CSA/UL approved.

WORKSURFACES

- Worksurfaces come in a variety of shapes and sizes. Essentially, they are 18", 24" or 30" deep and are available in 6" increments from 24" to 72" wide. Custom tops are available at a modest upcharge and on the same delivery schedule.
- Cable scoops located at the back of each worksurface provide routing of power and data cables.
- Metal inserts for the connection of supporting hardware.
- Thermally fused and high pressure laminate tops are available, both with tough PVC edging.
- All worksurfaces utilize balanced construction.
- Curved worksurfaces incorporate ergonomic design.

OVERHEAD STORAGE

Features:

- Steel and all laminate based options
- Panel mount and up-mount options
- Completely enclosed unit for 16" overheads
- Style dependent- ship fully assembled or knocked down
- 13.5" inside height for oversized binders
- Metal-to-metal connection
- Lock secures into bottom shelf
- Doors operate smoothly
- Flipper door retrofittable on site
- Safety bracket used for extra support
- Reinforcement built in for larger unit
- Can be removed and reconfigured without disassembly

Fronts:

- Open or closed fronts
- AODA compliant options available

Sizes:

- Overheads - 7 widths in 6" increments
- Shelves - 7 widths in 6" increments
- 13.5" deep welded overheads
- 14.2" deep AODA overheads
- 16.5" deep welded overheads for EDP, ring binder, letter/legal

Paint:

- Dry epoxy powder coating

PEDESTALS

Features:

- Premium quality steel reinforced welded construction
- Double wall construction on all drawer fronts
- Fully progressive suspension system
- Full pull
- Worksurface supporting option
- Full extension roller bearing glides on all file drawers
- Rubber bumpers for quietness
- Movable drawer divider in box drawers
 - Pencil Tray
 - Each file drawer includes a hanging file bar (22" and 28" depth only)
- 3 depths with varying filing capacity
- Random or specific keying instructions available

Construction:

- Double wall drawer fronts
- 18-20 gauge steel case components

Sizes:

- (Prime) 18", 22", 28" depth
- (9300) 19", 23", 29" depth

Types:

- Worksurface Supporting, Mobile, Freestanding

Paint:

- Dry epoxy powder coating

WARRANTIES AND PERFORMANCE

- Lifetime Warranty.
- Non Obsolescence Warranty.
- Aggressive product pricing.
- Reduced cost of assembly and reconfiguration.
- Exceptions: panel textiles, electrical devices and task lights - 5 years.
- ISO9001:2000 Registered.
- ISO14001:2004 Registered.
- Greenguard Certified.
- ANSI/BIFMA CGSB testing on all products.
- Run through capability.

PANELS • TECHNICAL INFORMATION

- Evolve panels are 2 7/8" thick. They are available in four (5) basic heights: 30", 42", 48", 54" and 66" and eight (8) widths: 18" to 60" in 6" increments.
- Individual fabric covered acoustic modules incorporated into a rigid steel frame.
- Opposite side of each module may have a different fabric within the same grade at no upcharge.
- If different grades of fabric are used on one panel, the entire panel must be priced at highest grade.
- A low profile top cap is included. It allows for storage of up to 8, 5mm (0.002") diameter data cables.
- No panel creep.
- All Panels, except Monolithic are composed of a 6" raceway module and a 24"

high base module. Subsequent heights are created by adding either a 12" high module or a 24" high module.

- Raceway openings are 1.37 x 2.68
- 12" high and 24" high modules of all types (fabric, laminate, glass, open) are available for field installation. Contact your Customer Service Representative for requirements and installation.
- Frosted glazing is available at an upcharge, please contact your Customer Service Representative.
- Laminate for laminate panels cannot be replaced in the field, complete module must be ordered.
- Writeboard for Writeboard panels cannot be replaced in the field, complete module must be ordered.

PANEL CONNECTORS • TECHNICAL INFORMATION

Panel Connectors

- Available in one-way, two-way, three-way or four-way based on the configuration.
- Available with either PVC or Aluminum Trims.
- 6" high connectors cannot be stacked on top of each other.

Panel Trims

- Available in PVC or Aluminum.

COMPONENTS

A. EVPERA66

End-of-Run Kit (Wall mount) Note: adds 1" to the width of a panel run.

B. EVPFA6636

Fabric Acoustic Panel Note: there is no panel creep.

C. EVPIC66

Inline Panel Connector

D. EVPCPA266

Two-Way Corner Post Note: trim kit included. Post Connectors can be custom manufactured with or without slots on one side only. Contact your Evolve Customer Service Representative for a special quote.

E. EVPVTLA66

Vertical "L" Trim Note: Can be purchased separately when required for reconfiguration

F. EVPVC66

Variable-Height Connector Note: Connector height must reference taller panel. (Must be ordered separately).

G. EVPTVA24

Panel Trim Variable-Height

H. EVPFA4236

Fabric Acoustic Panel

I. EVPTNTA36

Panel Top Notched Trim

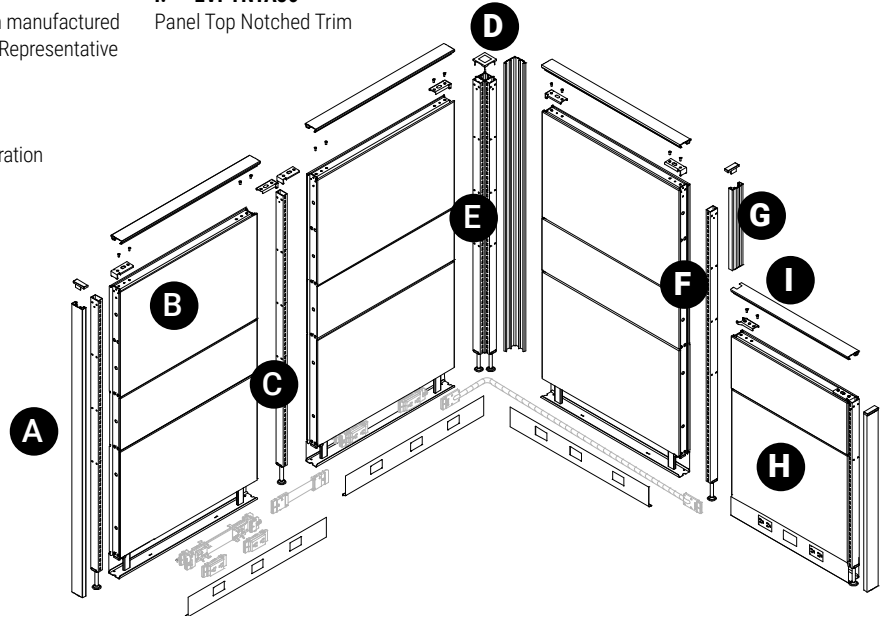

CONNECTORS • TECHNICAL INFORMATION

Slotted connectors and trim are included with each Variable-Height Corner Post. The height of each slotted connector must be specified when ordering a Variable-Height Corner Post. Slotted connector height is determined by the height of the connecting panel run.

Example:

Step 1 Specify base code listed on pricing page.

Fabric Acoustic Panel:

Step 2 Specify slotted connector heights.

Note: To specify height, use the first number of the connecting panel run height dimension.

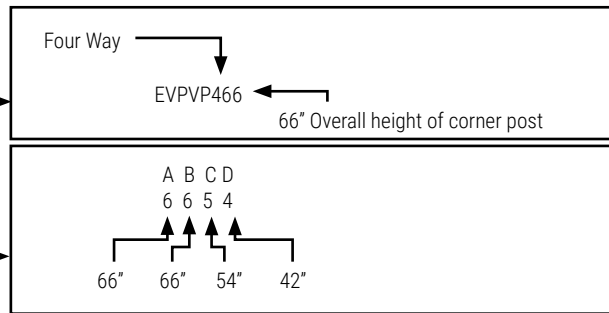

PANELS

- The entire Evolve panel and the processes to manufacture it are designed to save and protect the environment. Evolve panels are made from recycled materials and are 100% recyclable.
- Evolve makes it easy to select a panel function type and height that is suitable for your application.
- The extension module makes private offices available, with the use of Panel Extension Modules combined with a door.
- When Panel Extension Modules are used in the initial installation in conjunction with low panels (30" to 42"), future panel height flexibility is attained while maintaining storage hang-on capabilities up to 66".
- Panel frames can be totally disassembled in the field. Panel modules can be reconfigured or replaced and panel heights altered as changing circumstances demand.
- This level of flexibility makes it easy to select the correct height of panel to suit your requirements.
- Whiteboards incorporated into the panel remove the need for add-ons.
- The quality, and performance level of these panels has been tested to equal or exceed the requirements of the Canadian and US governments.
- Classified as acoustic, these panels meet the acoustical requirements of both Canadian and US governments.
- Solid steel panel frame combined with easy to assemble panel to panel clamps, create a rigid panel wall.
- Panel glide adjustment enables the client to deal with severe uneven floors of a building.

VOICE/DATA AND ELECTRIC POWER

- The base raceway cavity can accommodate 140 Category 5 data cables or 48 Category 5 data cables when the power distribution housings are present. In addition, 8 Category 5 data cables can be housed within a standard Panel Top Cap and 50 Category 5 cables can be accommodated in the optional High Profile Top Cap. This is a "true lay-in" method whereby cables can be run from the ceiling to worksurface without needing to be "fished".
- Evolve's 8 wire system provides two utility circuits plus two separate dedicated circuits (2+2).
- Snap-in Power Distribution Housings and lay-in Jumper and Pass-Through cables enable quick and simple electrical installation and modification by a qualified electrician. Circuits can easily be added, or exchanged (circuit #1 for circuit #2, circuit #1 for dedicated circuit #A or #B etc. if all are connected to base)
- The Desk Top Data/Power House attaches to the back of the worksurface to provide access to two simplex power outlets and two voice/data outlets.
- Standard Data Face Mount Plates can be used without the need of adapter plates (supplied by others).

WORKSURFACES

- The addition of custom sizes shows a commitment to client satisfaction that not every manufacturer offers. With this choice of product, we can tailor each installation to your requirements.
- This convenient scoop feature, together with a 3/8" gap between the worksurface and the panel, allows access to cables without having grommet holes in the worksurface.
- Metal-to-metal connection ensures that, no matter how many times you reconfigure your product, it will perform over the long term.
- Highest quality, thermally fused laminated surfaces ensure lasting durability. High pressure laminates are also available for those areas where rugged use is expected. A 3mm PVC edge banding is used on both options, to take the knocks of everyday wear and tear.
- Whether thermally fused or high pressure, all worksurfaces are manufactured with equal laminates on both sides of the worksurface to deter warpage.
- Curved worksurfaces are ergonomically designed to facilitate the interaction between the keyboard, mouse and worksurface.

STORAGE

- Steel construction guarantees the performance of the product over the long term. Welded joints with a full top, back and base ensure that the pedestal will sit square and adequately support the worksurface where necessary.
- Due to the quality of the construction and the slides, the pedestal drawers will continue to operate efficiently for the lifetime of the furniture. The rubber bumpers dampen the noise of closing a drawer and stop any metal-to-metal contact.
- The pencil tray is double width for extra storage.
- The glides enable you to level the cabinet to the floor and or worksurface. This convenient adjustment feature allows the installer to adjust the height of the cabinet while it is under the worksurface. This saves time in the installation process.
- For additional security and piece of mind. These locks can be keyed alike or master keyed for additional convenience.
- Quality construction with no exposed metal edges. Recessed handle offers uncluttered aesthetic.
- The construction of the drawer enables you to hang files from the drawer side so no extra hardware is necessary. File drawers accept legal, letter and metric sized files.
- Some manufacturers use the same drawer for their 24" deep pedestal as they do for their 30" deep pedestal. The 24" deep drawer gives you only 19.5" of filing. This is 25% extra filing in every file pedestal drawer.
- Worksurface supporting pedestal feature saves you money as you do not have to buy worksurface supporting hardware. Each pedestal comes with a finished end panel. The addition of a non handed bracket enables the pedestal to attach to a structural panel.
- This item, which is shipped knocked down, is more economically priced to minimize shipping damage. The lock is optional in the 12" overhead and included in the 13" overhead. The base shelf features a back lip which stops binders touching the fabric of the panel it is mounted on. All components are metal and the door slides are roller bearing for longer life.
- These rugged overhead units are extremely well priced yet accommodate a full load of binders with ease. They can be mounted above or below the worksurface.
- Storage Towers provide storage without pedestals or binder bins. This allows for greater flexibility in worksurface heights and increases the viability of 54" panels.
- "Environmentally friendly" epoxy powder coat is 15 times more durable in independent testing than a wet paint spray. This helps maintain the look of the product over its many years of service.

WARRANTIES AND PERFORMANCE

- For peace of mind over the long term, we cover you with a comprehensive warranty that is supported by our dealer network.
- We agree to make product available for a period of 20 years from the date of purchase. This product will be 100% compatible with your existing system.
- Evolve is priced well below other major "A" grade products on the market.
- Some installation companies claim that the Evolve System panels can be installed in half the time it takes to install most of our competitor's panels. This cost saving can amount to thousands of dollars over the lifetime of our furniture.
- Your assurance of consistent quality to an international standard. Evolve Systems is committed to design, manufacture and distribute superior quality office furniture, which meets or exceeds the requirements of our customers.
- Confirmation that Evolve is committed: (1) to providing product that, through their entire life cycle, minimize negative environmental impacts on the environment, (2) to continuous improvement to our environmental systems and programs and, (3) to comply to all relevant environmental legislation and regulations.
- Evolve Systems meets LEED requirements for office furniture.
- Evolve components are tested to the highest standard in the industry. This is your assurance of quality and longevity.
- On occasion, parts and pieces get missed. The run-through program is an emergency production space that we use to make items you need in a hurry.

WOOD GRAIN (WG) LAMINATE DIRECTION

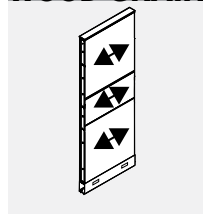

EVP Panels
With Exception of 66" high monolithic panels, they are vertical.

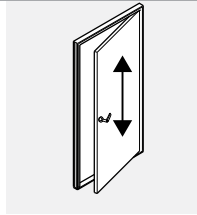

EVPD
Doors.

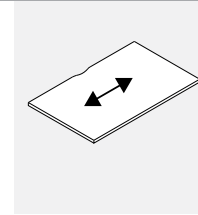

EVWS
Worksurfaces.

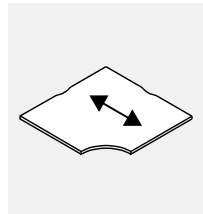

EVWCC
Worksurfaces.

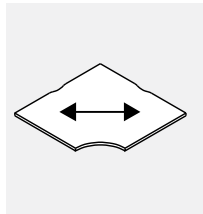

EVWCC-WG
Worksurfaces.

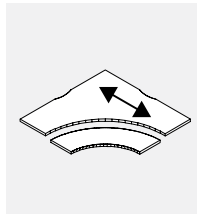

EVWCCK
Worksurfaces.

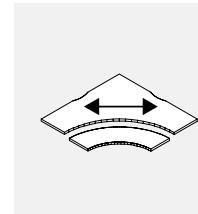

EVWCCK-WG
Worksurfaces.

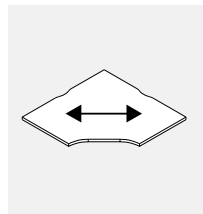

EVWCK-WG
Worksurfaces.

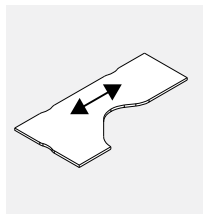

EVWCF
Worksurfaces.

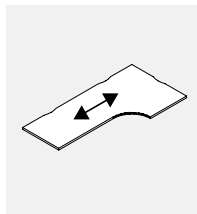

EVWCE
Worksurfaces.

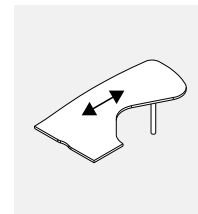

EVWHL/R
Worksurfaces.

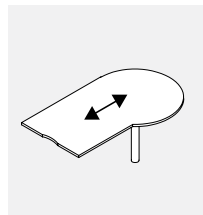

EVWP
Worksurfaces.

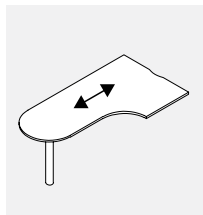

EVWPL/R
Worksurfaces.

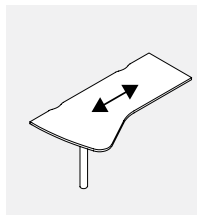

EVWWL/R
Worksurfaces.

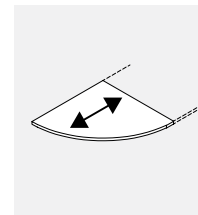

EVQR and EVWQRC
Worksurfaces.

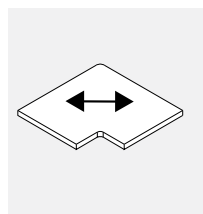

EVWTCL-WG
Worksurfaces.

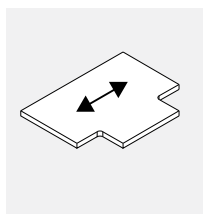

EVWTC
Worksurfaces.

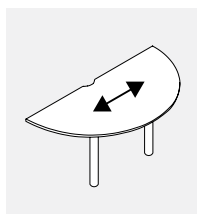

EVWR
Worksurfaces.

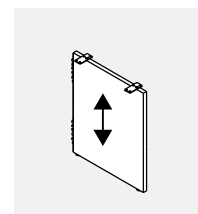

EVHP/EVLMP
End Panels.

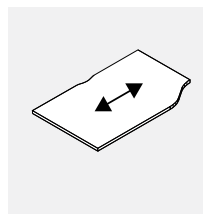

EVWVL/R
Worksurfaces.

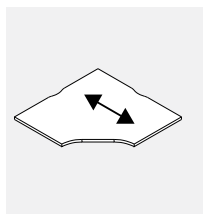

EVWCK
Worksurfaces.

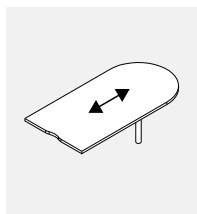

EVWD
Worksurfaces.

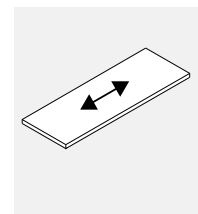

EVWT, EVWTV, EVWTE, EVWTEV, EVWTD, EVWTDV, EVWTDG
Worksurfaces.

WG - indiscated woodgrain in cross pattern

ORDERS

Each Order Must Include

Purchase Order
 Layout showing where the image(s) appear in the run of panels.
 A completed Price Chart, showing the location of the image(s) on each appropriate panel.

Artwork must be submitted in accordance with the following artwork specifications.

NOTE: Final artwork specification approval must be given before order can be processed.

Transfer Devices

• E-mail up to 10MB to your Evolve/Global Contract Customer Service Representative.

• Courier CD/DVD/USB stick to your Evolve/Global Contract Customer Service Representative.

Artwork Specifications

- Non-Photographic artwork should be vector art. Saved in Adobe Illustrator (.ai) or as an EPS (.eps)
- All bitmap or photographic artwork has to be at a minimum of 100 dpi at the full size of the panel to be printed.
- We accept Adobe CS5 files.
- Any linked files must be included or imbedded.

- Leave any PSD files un-flattened
- All fonts must be converted to outlines.
- Do not convert to CMYK, leave all images as RGB if possible
- No Word, Powerpoint, Publisher or other Microsoft files can be used.
- Include a PDF or .jpg for reference when sending native Photoshop or Illustrator format files.

Colour Matching

• A Pantone colour reference must be supplied or we cannot accept responsibility for correct colour or colour correction.

• When it is not possible to refer to Pantone colours, we will do our best to meet your requirements.

Image Clarity

• We will advise should the selected image not lend itself to the element size requested.

NOTE:

We reserve the right to put an order on hold when the files are found to be incomplete or when documents have been either incorrectly saved, fonts have not been converted to curves or the job appears not to be commercially acceptable.

Image Bleed:

To facilitate placement on the panel. Extension of the image past the finished visible area of the panel (bleed) is required.

• Evolve Panels need a 3" bleed on all sides.

Example of Image resolution:

The resolution required for a 36 wide x 24 high Evolve panel at 100dpi (minimum resolution)

The resolution required for a 36 wide x 24 high Evolve panel at 300dpi (higher quality)

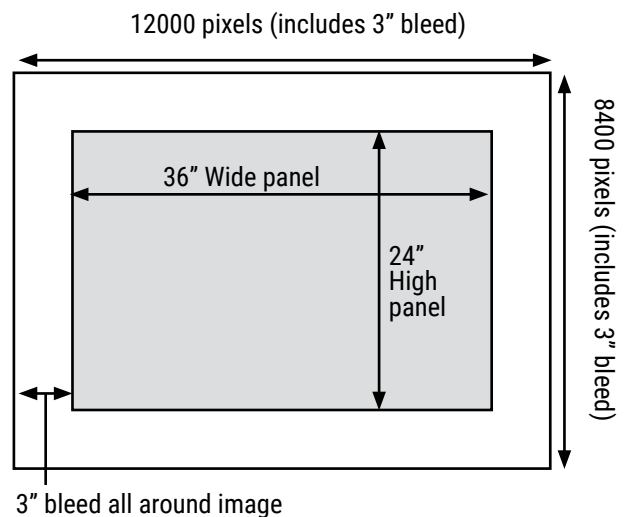
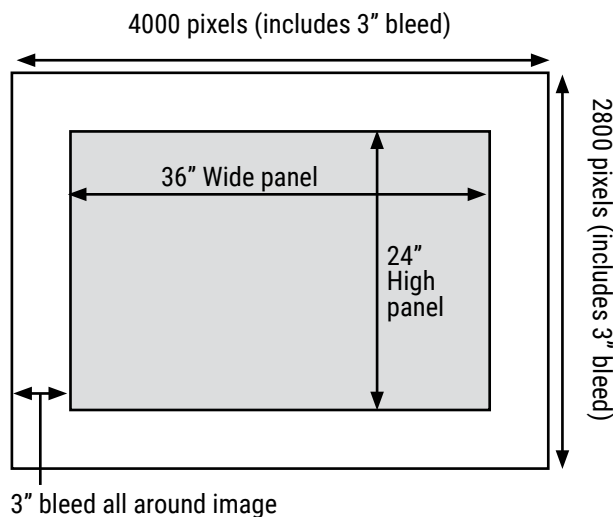

Pricing Initial Set-Up Charge per Image: \$264 net

Evolve 12" Modules

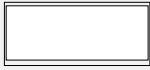

PANEL WIDTH	LIST PRICE
24"	144
30"	179
36"	217
42"	249
48"	289
54"	329
60"	366

- Applies to the following panels:
- EVPFA
 - EVPPF
 - EVPF1W
 - EVPF2W
 - EVPF1S
 - EVPF2S
 - EVPFGT
 - EVPPFGTU
 - EVPFOL
 - EVPPPOL
 - EVPFO
 - EVPPFO
 - EVPFE12
 - EVPFE

Evolve 24" Modules



PANEL WIDTH	LIST PRICE
24"	283
30"	363
36"	433
42"	508
48"	579
54"	655
60"	725

- Applies to the following panels:
- EVPFA
 - EVPPF
 - EVPF1W
 - EVPF2W
 - EVPF1S
 - EVPF2S
 - EVPFGT
 - EVPPFGTU
 - EVPFOL
 - EVPPGTX
 - EVPPFO
 - EVPPFE12
 - EVPPFE

Evolve Monolithic Panels

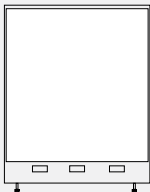

PANEL WIDTH	HEIGHT	LIST PRICE
	42"	48"
24"	42	48
30"	433	508
36"	555	652
42"	665	779
48"	779	908
54"	891	1038
60"	999	1168
		54"
		66"
		54
		66
		579
		726
		741
		928
		891
		1112
		1038
		1298
		1186
		1482
		1333
		1666

- Applies to the following panels:
- EVPFAM

Note: Prices shown are an upcharge to the panel price, please add to the list price of panel which you are specifying the graphic for.

EVOLVE SYSTEMS - GRAPHIC PANEL EXAMPLE PROCEDURE

STEP 1: Customer orders the following EVPFA6636 panel with;

- Bottom module inside face (24/36 size fabric) with image 01.
- Middle module inside face (12/36 size fabric) with image 02.
- All other fabric material is regular fabric - top module inside face and all outside module faces.

STEP 2: On the regular panel - replace fabric pieces with corresponding graphic pieces.

STEP 3: Enter separate lines in order for the corresponding fabric image graphic pieces:

- EVPGRP1236 for the middle module inside face
- EVPGRP2436 for the bottom module inside face

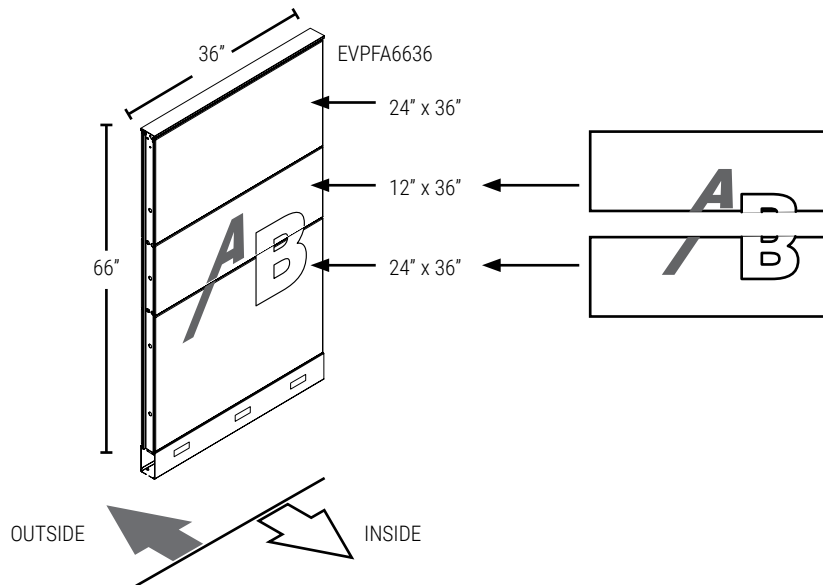

Note: To order, please use graphic codes below

(A)
EVPGRP1236

(B)
EVPGRP2436

PANELS • TECHNICAL INFORMATION

- Evolve panels are 2 7/8" thick. They are available in four (5) basic heights: 30", 42", 48" and 54" and eight (8) widths: 18" to 60" in 6" increments.
- Individual fabric covered acoustic modules incorporated into a rigid steel frame.
- Opposite side of each module may have a different fabric within the same grade at no upcharge.
- If different grades of fabric are used on one panel, the entire panel must be priced at highest grade.
- A low profile top cap is included.
- No panel creep.
- All Panels, except Monolithic are composed of a 6" raceway module and a 24" high base module. Subsequent heights are created by adding either a 12" high module or a 24" high module.
- Raceway openings are 1.37 x 2.68
- 12" high and 24" high modules of all types (fabric, laminate, glass, open) are available for field installation. Contact your Customer Service Representative.
- Frosted glazing is available at an upcharge, please contact your Customer Service Representative.
- Laminate for laminate panels cannot be replaced in the field, complete module must be ordered.
- Writeboard for Writeboard panels cannot be replaced in the field, complete module must be ordered.
- Panels 18" wide have no knockout, panels 24" wide have 1 knockout, panels 30" have 2 knockouts and panels 36" to 60" have 3 knockouts.

PANEL EXTENSION MODULES • TECHNICAL INFORMATION

- 6", 12", 18" and 24" Panel Extension Modules attach to the top of the panel.
- Modules can be stacked to add privacy or divide space.
- Each side of a fabric module may have a different fabric within the same grade at no upcharge.
- When extension modules are used, the double or single clamp is moved to the top of the extension for panel connection.

PANELS • GUIDELINES FOR ORDERING PRODUCT

The price list uses a numbering system with meaningful alphanumeric characters to create a simple-to-understand product number. This makes specifying the product much easier and more accurate.

EXAMPLE OF PANEL CODE

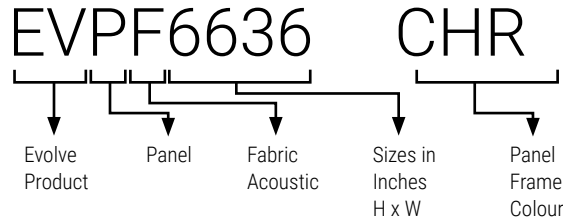

I1	AN50	Inside Fabric Position #1
I2	AN50	Inside Fabric Position #2
I3	AN50	Inside Fabric Position #3
O1	BE21	Outside Fabric Position #1
O2	BE21	Outside Fabric Position #2
O3	BE21	Outside Fabric Position #3

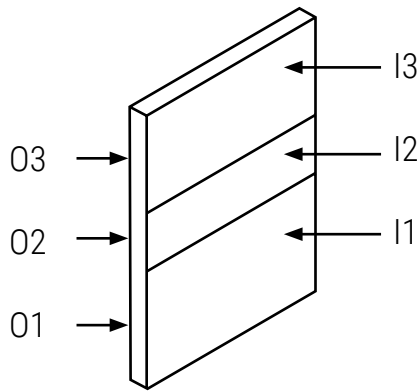

HOW TO SPECIFY

- Specify Evolve panel type and size by code.
- Specify panel frame finish - ie. CHR (Charcoal).
- Specify all necessary panel fabric options.

NOTE: If different grades of fabric are used on one panel, the entire panel must be priced out at the higher grade.

EVPFA • Fabric Acoustic Panel

- Standard panels incorporate a single 12" or 24" module or combination of 12" and 24" modules above the 30" base section. Application is based on panel height.
- 66" high panel can be configured with 12" at the top of the panel, see EVPFA66-S.

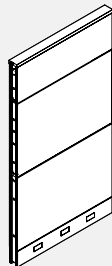
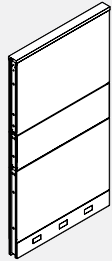
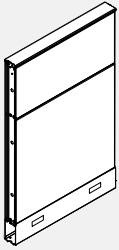

PRODUCT CODE	PRICE		SIZE/ INCHES			WEIGHT LBS	VOL FT ³
	GR 1	GR 2	H	W	D		
EVPFA3018	305	317	30	18	2.875	15.38	1.23
EVPFA3024	318	336	30	24	2.875	18.20	1.63
EVPFA3030	352	372	30	30	2.875	21.76	2.00
EVPFA3036	378	401	30	36	2.875	24.80	2.38
EVPFA3042	408	434	30	42	2.875	26.49	2.76
EVPFA3048	451	482	30	48	2.875	32.00	3.13
EVPFA3054	486	520	30	54	2.875	35.31	3.51
EVPFA3060	522	562	30	60	2.875	38.20	3.89
EVPFA4218	338	354	42	18	2.875	20.58	1.71
EVPFA4224	354	382	42	24	2.875	24.60	2.31
EVPFA4230	412	443	42	30	2.875	29.35	2.81
EVPFA4236	446	482	42	36	2.875	35.60	3.38
EVPFA4242	509	548	42	42	2.875	39.29	3.92
EVPFA4248	548	593	42	48	2.875	43.20	4.45
EVPFA4254	607	657	42	54	2.875	47.52	4.98
EVPFA4260	665	721	42	60	2.875	51.60	5.52
EVPFA5418	363	385	54	18	2.875	23.98	2.19
EVPFA5424	397	431	54	24	2.875	27.80	2.94
EVPFA5430	452	490	54	30	2.875	33.15	3.62
EVPFA5436	505	550	54	36	2.875	37.40	4.31
EVPFA5442	570	625	54	42	2.875	40.69	4.99
EVPFA5448	634	694	54	48	2.875	48.20	5.67
EVPFA5454	691	758	54	54	2.875	52.92	6.35
EVPFA5460	740	814	54	60	2.875	57.40	7.03
EVPFA6618	455	486	66	18	2.875	29.98	2.68
EVPFA6624	490	536	66	24	2.875	35.00	3.58
EVPFA6630	544	593	66	30	2.875	41.54	4.40
EVPFA6636	638	697	66	36	2.875	49.00	5.23
EVPFA6642	722	790	66	42	2.875	54.29	6.06
EVPFA6648	774	850	66	48	2.875	60.20	6.08
EVPFA6654	842	926	66	54	2.875	65.93	7.70
EVPFA6660	909	1001	66	60	2.875	71.60	8.53
EVPFA6618S	455	486	66	18	2.875	29.98	2.68
EVPFA6624S	490	536	66	24	2.875	35.00	3.58
EVPFA6630S	544	593	66	30	2.875	41.54	4.40
EVPFA6636S	638	695	66	36	2.875	49.00	5.23
EVPFA6642S	722	790	66	42	2.875	54.29	6.06
EVPFA6648S	774	850	66	48	2.875	60.20	6.88
EVPFA6654S	842	926	66	54	2.875	65.93	6.88
EVPFA6660S	909	1001	66	60	2.875	71.60	8.53

EVFPF • Fabric Acoustic Panel Premium

• Premium panels incorporate 12" high acoustic modules above the 30" base section.

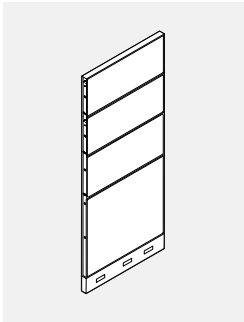
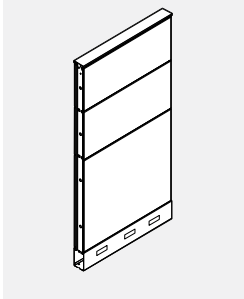

PRODUCT CODE	PRICE		SIZE/ INCHES			WEIGHT LBS	VOL FT ³
	GR 1	GR 2	H	W	D		
EVFPF5418	422	450	54	18	2.875	26.18	2.19
EVFPF5424	451	484	54	24	2.875	31.40	2.06
EVFPF5430	499	540	54	30	2.875	37.34	2.58
EVFPF5436	589	634	54	36	2.875	46.80	3.09
EVFPF5442	661	718	54	42	2.875	52.49	3.61
EVFPF5448	707	765	54	48	2.875	54.80	4.36
EVFPF5454	755	824	54	54	2.875	60.13	6.35
EVFPF5460	797	872	54	60	2.875	65.40	5.16
EVFPF6618	537	568	66	18	2.875	32.18	2.68
EVFPF6624	574	613	66	24	2.875	38.60	3.58
EVFPF6630	634	686	66	30	2.875	45.73	4.40
EVFPF6636	747	809	66	36	2.875	58.40	5.23
EVFPF6642	843	911	66	42	2.875	66.09	6.06
EVFPF6648	905	983	66	48	2.875	66.80	6.88
EVFPF6654	985	1067	66	54	2.875	73.14	7.70
EVFPF6660	1055	1147	66	60	2.875	79.60	8.53

EVPFAM • Fabric Acoustic Panel Monolithic

• Monolithic panels incorporate a single acoustic module within a solid rigid steel frame.

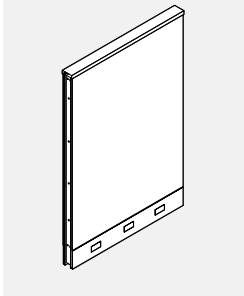

PRODUCT CODE	PRICE		SIZE/ INCHES			WEIGHT LBS	VOL FT ³
	GR 1	GR 2	H	W	D		
EVPFAM4218	333	364	42	18	2.875	20.58	1.71
EVPFAM4224	355	394	42	24	2.875	23.40	2.31
EVPFAM4230	406	450	42	30	2.875	26.96	2.85
EVPFAM4236	436	487	42	36	2.875	30.00	3.38
EVPFAM4242	483	543	42	42	2.875	31.69	3.92
EVPFAM4248	525	593	42	48	2.875	37.20	4.45
EVPFAM4254	579	653	42	54	2.875	40.51	4.98
EVPFAM4260	629	711	42	60	2.875	43.40	5.52
EVPFAM4818	340	371	48	18	2.875	21.38	1.92
EVPFAM4824	374	410	48	24	2.875	24.40	2.62
EVPFAM4830	431	476	48	30	2.875	27.76	3.23
EVPFAM4836	469	520	48	36	2.875	30.80	3.85
EVPFAM4842	524	584	48	42	2.875	32.49	4.45
EVPFAM4848	572	637	48	48	2.875	37.80	5.06
EVPFAM4854	630	704	48	54	2.875	41.31	5.66
EVPFAM4860	684	767	48	60	2.875	44.20	6.27
EVPFAM5418	342	374	54	18	2.875	24.58	2.19
EVPFAM5424	376	415	54	24	2.875	27.40	2.94
EVPFAM5430	437	482	54	30	2.875	30.96	3.62
EVPFAM5436	486	541	54	36	2.875	34.00	4.31
EVPFAM5442	545	605	54	42	2.875	35.69	4.99
EVPFAM5448	591	661	54	48	2.875	41.20	5.67
EVPFAM5454	651	728	54	54	2.875	44.51	6.35
EVPFAM5460	712	796	54	60	2.875	47.40	7.03
EVPFAM6618	425	455	66	18	2.875	27.58	2.68
EVPFAM6624	463	503	66	24	2.875	30.40	3.58
EVPFAM6630	524	573	66	30	2.875	33.96	4.40
EVPFAM6636	608	663	66	36	2.875	37.00	5.23
EVPFAM6642	684	743	66	42	2.875	38.69	6.06
EVPFAM6648	743	811	66	48	2.875	44.20	6.88
EVPFAM6654	826	900	66	54	2.875	47.51	7.70
EVPFAM6660	909	991	66	60	2.875	50.40	8.53

EVPH1S • Laminate Panel - One Side

• Laminate faces on one side of all modules provide durable, washable surfaces. Opposite side is fabric.

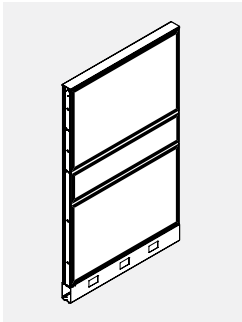
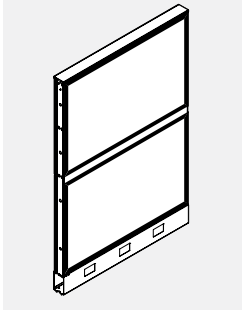

PRODUCT CODE	PRICE		SIZE / INCHES			WEIGHT LBS	VOL FT ³
	GR 1	GR 2	H	W	D		
EVPH1S3018	364	370	30	18	2.875	15.88	1.23
EVPH1S3024	434	443	30	24	2.875	18.70	1.63
EVPH1S3030	509	518	30	30	2.875	22.26	2.00
EVPH1S3036	578	591	30	36	2.875	24.85	2.58
EVPH1S3042	656	670	30	42	2.875	26.99	2.76
EVPH1S3048	712	724	30	48	2.875	32.05	3.13
EVPH1S3054	790	806	30	54	2.875	35.81	3.51
EVPH1S3060	864	883	30	60	2.875	38.07	3.89
EVPH1S4218	432	441	42	18	2.875	21.38	1.71
EVPH1S4224	516	528	42	24	2.875	22.13	2.31
EVPH1S4230	603	615	42	30	2.875	30.15	2.31
EVPH1S4236	692	713	42	36	2.875	36.40	3.38
EVPH1S4242	784	805	42	42	2.875	40.09	3.92
EVPH1S4248	853	877	42	48	2.875	44.00	4.45
EVPH1S4254	949	973	42	54	2.875	48.32	4.98
EVPH1S4260	1038	1066	42	60	2.875	52.40	5.52
EVPH1S5418	508	520	54	18	2.875	24.98	2.19
EVPH1S5424	612	629	54	24	2.875	28.80	2.94
EVPH1S5430	720	740	54	30	2.875	34.15	3.62
EVPH1S5436	824	849	54	36	2.875	38.40	4.31
EVPH1S5442	931	959	54	42	2.875	41.69	4.99
EVPH1S5448	1018	1051	54	48	2.875	49.20	5.67
EVPH1S5454	1132	1168	54	54	2.875	53.92	6.35
EVPH1S5460	1245	1286	54	60	2.875	58.40	7.03
EVPH1S6618	629	645	66	18	2.875	31.29	2.68
EVPH1S6624	758	780	66	24	2.875	36.30	3.58
EVPH1S6630	885	911	66	30	2.875	42.84	4.40
EVPH1S6636	1022	1052	66	36	2.875	50.30	5.23
EVPH1S6642	1165	1197	66	42	2.875	55.59	6.06
EVPH1S6648	1265	1303	66	48	2.875	61.50	5.23
EVPH1S6654	1406	1448	66	54	2.875	67.23	7.70
EVPH1S6660	1549	1600	66	60	2.875	72.90	8.53

EVPH2S • Laminate Panel - Two Sides

• Laminate faces on both sides of all modules provide durable, washable surfaces.

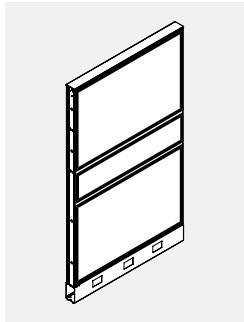
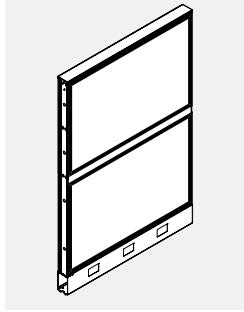

PRODUCT CODE	PRICE	SIZE/ INCHES			WEIGHT LBS	VOL FT ³
		H	W	D		
EVPH2S3018	406	30	18	2.875	16.38	1.23
EVPH2S3024	495	30	24	2.875	19.20	1.63
EVPH2S3030	586	30	30	2.875	22.76	2.00
EVPH2S3036	670	30	36	2.875	25.80	2.58
EVPH2S3042	762	30	42	2.875	27.49	2.76
EVPH2S3048	852	30	48	2.875	33.00	3.35
EVPH2S3054	943	30	54	2.875	36.31	3.95
EVPH2S3060	1022	30	60	2.875	39.20	4.52
EVPH2S4218	483	42	18	2.875	22.18	1.71
EVPH2S4224	586	42	24	2.875	26.20	2.31
EVPH2S4230	691	42	30	2.875	30.95	2.85
EVPH2S4236	802	42	36	2.875	37.20	3.38
EVPH2S4242	917	42	42	2.875	40.89	3.92
EVPH2S4248	1026	42	48	2.875	42.80	4.45
EVPH2S4254	1129	42	54	2.875	49.12	5.52
EVPH2S4260	1232	42	60	2.875	53.20	5.52
EVPH2S5418	565	54	18	2.875	25.98	2.19
EVPH2S5424	693	54	24	2.875	29.80	2.94
EVPH2S5430	824	54	30	2.875	35.15	3.62
EVPH2S5436	955	54	36	2.875	39.40	4.31
EVPH2S5442	1090	54	42	2.875	42.69	4.99
EVPH2S5448	1231	54	48	2.875	50.20	5.67
EVPH2S5454	1352	54	54	2.875	52.92	6.35
EVPH2S5460	1473	54	60	2.875	59.40	7.03
EVPH2S6618	712	66	18	2.875	32.58	2.68
EVPH2S6624	877	66	24	2.875	37.60	3.58
EVPH2S6630	1038	66	30	2.875	44.14	4.40
EVPH2S6636	1205	66	36	2.875	51.60	5.23
EVPH2S6642	1383	66	42	2.875	56.89	6.06
EVPH2S6648	1549	66	48	2.875	62.80	6.88
EVPH2S6654	1713	66	54	2.875	68.53	7.70
EVPH2S6660	1870	66	60	2.875	74.20	8.53

EVPF1W • Writeboard Panel - One Side

• Writing surface is built into the top module on one side of the panel, alleviating the need for a panel-mounted Writeboard.
 • Use of erasable Writeboard markers only.

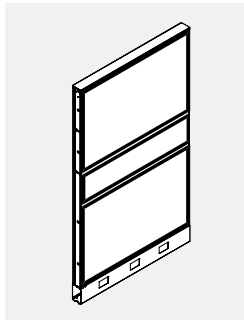
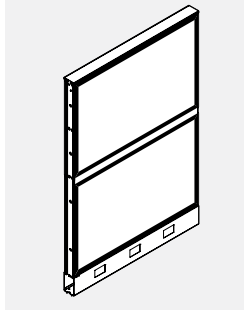

PRODUCT CODE	PRICE		SIZE/ INCHES			WEIGHT LBS	VOL FT ³
	GR 1	GR 2	H	W	D		
EVPF1W5418	441	456	54	18	2.875	24.98	2.19
EVPF1W5424	548	575	54	24	2.875	28.80	2.94
EVPF1W5430	659	691	54	30	2.875	34.15	3.62
EVPF1W5436	731	766	54	36	2.875	38.40	4.31
EVPF1W5442	826	867	54	42	2.875	41.69	4.99
EVPF1W5448	930	975	54	48	2.875	49.20	5.67
EVPF1W5454	1035	1069	54	54	2.875	53.92	6.35
EVPF1W5460	1140	1198	54	60	2.875	58.40	7.03
EVPF1W6618	562	582	66	18	2.875	30.48	2.57
EVPF1W6624	692	724	66	24	2.875	35.50	3.58
EVPF1W6630	823	863	66	30	2.875	42.04	4.40
EVPF1W6636	916	963	66	36	2.875	49.50	5.23
EVPF1W6642	1037	1091	66	42	2.875	54.79	6.06
EVPF1W6648	1157	1220	66	48	2.875	60.70	6.88
EVPF1W6654	1290	1357	66	54	2.875	66.43	7.70
EVPF1W6660	1422	1498	66	60	2.875	72.10	8.53

EVVPF2W • Writeboard Panel - Two Side

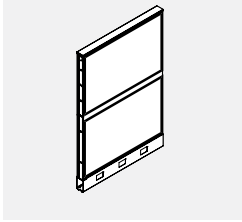

- Writing surface is built into the top module on both sides of the panel, alleviating the need for 2 panel-mounted Writeboards.
- Use of erasable Writeboard markers only.

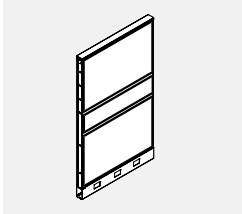

PRODUCT CODE	PRICE		SIZE/ INCHES			WEIGHT LBS	VOL FT ³
	GR 1	GR 2	H	W	D		
EVVPF2W5418	476	487	54	18	2.875	25.48	2.19
EVVPF2W5424	596	613	54	24	2.875	29.30	2.94
EVVPF2W5430	746	763	54	30	2.875	34.65	3.62
EVVPF2W5436	809	833	54	36	2.875	38.90	4.31
EVVPF2W5442	917	943	54	42	2.875	42.19	4.99
EVVPF2W5448	1072	1103	54	48	2.875	49.70	5.67
EVVPF2W5454	1196	1231	54	54	2.875	54.51	6.35
EVVPF2W5460	1317	1354	54	60	2.875	58.90	7.03
EVVPF2W6618	593	613	66	18	2.875	30.98	2.57
EVVPF2W6624	737	762	66	24	2.875	36.00	3.58
EVVPF2W6630	908	937	66	30	2.875	42.54	4.40
EVVPF2W6636	992	1026	66	36	2.875	50.00	5.23
EVVPF2W6642	1128	1169	66	42	2.875	55.29	6.06
EVVPF2W6648	1294	1340	66	48	2.875	61.20	6.88
EVVPF2W6654	1442	1496	66	54	2.875	66.93	7.70
EVVPF2W6660	1595	1653	66	60	2.875	72.60	8.53

EVVPF1S • Slat Wall Panel - One Sided

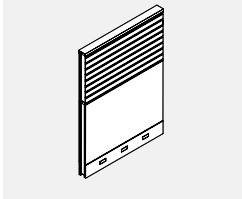

- Standard panels incorporating a single 12" or 24" module or combination of 12" and 24" modules above the 30" base section.
- Slat module is only on one side, fabric on the other.
- 66" high panel can be configured with either a 24" slat module at the top, see EVVPF1S66, or a 12" slat module at the centre, see EVVPF1S66M.

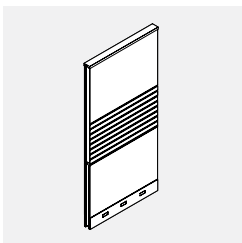
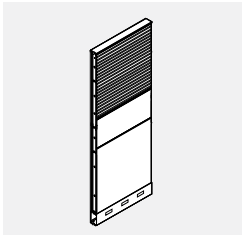
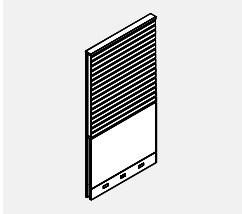

PRODUCT CODE	PRICE		SIZE/ INCHES			WEIGHT LBS	VOL FT ³
	GR 1	GR 2	H	W	D		
EVVPF1S4218	383	399	42	18	2.875	13.50	1.71
EVVPF1S4224	419	441	42	24	2.875	33.50	2.31
EVVPF1S4230	490	517	42	30	2.875	45.50	2.85
EVVPF1S4236	542	573	42	36	2.875	49.50	3.38
EVVPF1S4242	625	658	42	42	2.875	54.50	3.92
EVVPF1S4248	671	711	42	48	2.875	60.50	4.47
EVVPF1S4254	747	788	42	54	2.875	67.50	4.98
EVVPF1S4260	819	865	42	60	2.875	74.50	5.52
EVVPF1S5418	464	484	54	18	2.875	36.50	2.19
EVVPF1S5424	527	552	54	24	2.875	36.40	2.94
EVVPF1S5430	612	643	54	30	2.875	40.40	3.62
EVVPF1S5436	694	731	54	36	2.875	44.40	4.31
EVVPF1S5442	790	830	54	42	2.875	46.40	5.67
EVVPF1S5448	884	929	54	48	2.875	48.40	5.67
EVVPF1S5454	969	1021	54	54	2.875	50.00	6.35
EVVPF1S5460	1050	1106	54	60	2.875	52.40	7.03
EVVPF1S6618	561	584	66	18	2.875	42.00	2.57
EVVPF1S6624	623	656	66	24	2.875	48.00	3.58
EVVPF1S6630	705	746	66	30	2.875	50.00	4.40
EVVPF1S6636	829	879	66	36	2.875	54.00	5.23
EVVPF1S6642	938	995	66	42	2.875	60.00	6.06
EVVPF1S6648	1022	1084	66	48	2.875	67.00	6.88
EVVPF1S6654	1119	1187	66	54	2.875	80.00	7.07
EVVPF1S6660	1216	1292	66	60	2.875	86.00	8.53
EVVPF1S6618M	503	534	66	18	2.875	42.00	2.57
EVVPF1S6624M	553	592	66	24	2.875	48.00	3.58
EVVPF1S6630M	623	668	66	30	2.875	50.00	4.40
EVVPF1S6636M	734	788	66	36	2.875	54.00	5.23
EVVPF1S6642M	835	896	66	42	2.875	60.00	6.06
EVVPF1S6648M	896	966	66	48	2.875	67.00	6.88
EVVPF1S6654M	983	1060	66	54	2.875	80.00	7.70
EVVPF1S6660M	1063	1147	66	60	2.875	86.00	8.53

EVVPF2S • Slat Wall Module Panel - Two Sided

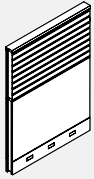

- Standard panels incorporating a single 12" or 24" module or combination of 12" and 24" modules above the 30" base section.
- Slat module is only on both sides.
- 66" high panel can be configured with either a 24" slat module at the top, see EVVPF2S66, or a 12" slat module at the centre, see EVVPF2S66-M.

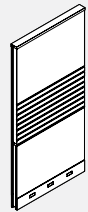
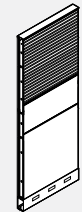
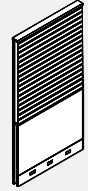

PRODUCT CODE	PRICE		SIZE/ INCHES			WEIGHT VOL	
	GR 1	GR 2	H	W	D	LBS	FT ³
EVVPF2S4218	411	425	42	18	2.875	16.50	1.71
EVVPF2S4224	459	477	42	24	2.875	36.50	2.31
EVVPF2S4230	543	563	42	30	2.875	48.50	2.85
EVVPF2S4236	604	627	42	36	2.875	52.50	3.38
EVVPF2S4242	694	722	42	42	2.875	57.50	3.92
EVVPF2S4248	755	786	42	48	2.875	63.50	4.47
EVVPF2S4254	842	877	42	54	2.875	70.50	4.98
EVVPF2S4260	922	960	42	60	2.875	77.50	5.52
EVVPF2S5418	542	553	54	18	2.875	38.50	2.19
EVVPF2S5424	631	649	54	24	2.875	44.40	2.94
EVVPF2S5430	744	761	54	30	2.875	46.40	3.62
EVVPF2S5436	852	877	54	36	2.875	48.40	4.31
EVVPF2S5442	973	1000	54	42	2.875	50.40	4.99
EVVPF2S5448	1095	1128	54	48	2.875	52.40	5.67
EVVPF2S5454	1205	1239	54	54	2.875	54.40	6.35
EVVPF2S5460	1315	1352	54	60	2.875	56.40	7.03
EVVPF2S6618	634	655	66	18	2.875	45.00	2.57
EVVPF2S6624	725	752	66	24	2.875	51.00	3.58
EVVPF2S6630	835	865	66	30	2.875	53.00	4.40
EVVPF2S6636	986	1023	66	36	2.875	57.00	5.23
EVVPF2S6642	1125	1167	66	42	2.875	63.00	6.06
EVVPF2S6648	1234	1279	66	48	2.875	70.40	6.88
EVVPF2S6654	1358	1409	66	54	2.875	83.40	7.70
EVVPF2S6660	1482	1540	66	60	2.875	89.40	8.53
EVVPF2S6618M	535	557	66	18	2.875	45.00	2.57
EVVPF2S6624M	593	627	66	24	2.875	51.00	3.58
EVVPF2S6630M	672	714	66	30	2.875	53.00	4.40
EVVPF2S6636M	797	846	66	36	2.875	57.00	5.23
EVVPF2S6642M	908	962	66	42	2.875	63.00	6.06
EVVPF2S6648M	977	1040	66	48	2.875	70.40	6.88
EVVPF2S6654M	1074	1143	66	54	2.875	83.40	7.70
EVVPF2S6660M	1168	1241	66	60	2.875	89.40	8.53

EVVPF2S-F • Frameless Slat Wall Module Panel - Two Sided

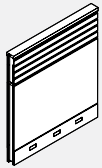

- Slat Wall is manufactured with 2 snap-in sections.
- Accessories can be hung on Slat Wall. Please see accessories section for additional details.
- For 42" H Slat Wall Panel only Aluminum Top Trim can be used. Aluminum Top Trim is included.
- Stackability: Evolve panels can be increased in height in 6", 12" and 24" increments. See module listing for part numbers.

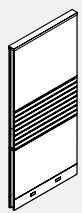
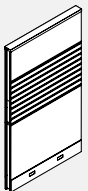

PRODUCT CODE	PRICE		SIZE/ INCHES			WEIGHT VOL	
	GR 1	GR 2	H	W	D	LBS	FT ³
EVVPF2S4224F	412	431	42	24	2.875	33.50	2.31
EVVPF2S4230F	485	507	42	30	2.875	45.50	2.81
EVVPF2S4236F	567	590	42	36	2.875	49.50	3.38
EVVPF2S4242F	641	668	42	42	2.875	54.50	3.92
EVVPF2S4248F	711	741	42	48	2.875	60.50	4.45
EVVPF2S4254F	785	820	42	54	2.875	67.50	4.98
EVVPF2S4260F	865	903	42	60	2.875	74.50	5.52
EVVPF2S5424F	563	589	54	24	2.875	36.40	2.94
EVVPF2S5430F	658	689	54	30	2.875	40.40	3.62
EVVPF2S5436F	763	801	54	36	2.875	44.40	4.31
EVVPF2S5442F	867	908	54	42	2.875	46.60	4.99
EVVPF2S5448F	962	1007	54	48	2.875	48.40	5.67
EVVPF2S5454F	1090	1142	54	54	2.875	50.40	6.35
EVVPF2S5460F	1173	1232	54	60	2.875	52.40	7.03
EVVPF2S6624F	623	656	66	24	2.875	48.00	3.58
EVVPF2S6630F	726	770	66	30	2.875	50.00	4.40
EVVPF2S6636F	860	908	66	36	2.875	54.00	5.23
EVVPF2S6642F	966	1022	66	42	2.875	60.00	6.06
EVVPF2S6648F	1069	1132	66	48	2.875	67.00	6.08
EVVPF2S6654F	1177	1244	66	54	2.875	80.00	7.70
EVVPF2S6660F	1294	1369	66	60	2.875	86.00	8.53

EVPFGT • Fabric Glazed Panel - Tempered Glass

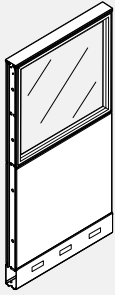

- Fabric Glazed Panel consists of individual fabric covered acoustic module in lower position(s) with one 12" or 24" glazed module in upper position.
- Glazing is replaceable on site.

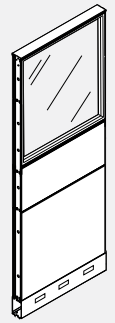

PRODUCT CODE	PRICE		SIZE/ INCHES			WEIGHT	VOL
	GR 1	GR 2	H	W	D	LBS	FT ³
EVPFGT4218	406	419	42	18	2.875	23.96	1.71
EVPFGT4224	478	494	42	24	2.875	28.98	2.31
EVPFGT4230	542	562	42	30	2.875	34.62	2.85
EVPFGT4236	609	633	42	36	2.875	39.76	3.38
EVPFGT4242	673	699	42	42	2.875	43.45	3.92
EVPFGT4248	736	766	42	48	2.875	51.56	4.45
EVPFGT4254	826	862	42	54	2.875	56.87	4.98
EVPFGT4260	911	949	42	60	2.875	61.95	5.52
EVPFGT5418	448	459	54	18	2.875	28.25	2.19
EVPFGT5424	520	539	54	24	2.875	34.76	2.94
EVPFGT5430	605	625	54	30	2.875	41.80	3.62
EVPFGT5436	688	713	54	36	2.875	48.34	4.31
EVPFGT5442	770	796	54	42	2.875	53.12	4.99
EVPFGT5448	840	870	54	48	2.875	62.11	5.67
EVPFGT5454	973	1007	54	54	2.875	68.42	6.35
EVPFGT5460	1106	1143	54	60	2.875	74.49	7.03
EVPFGT6618	569	589	66	18	2.875	34.25	2.68
EVPFGT6624	660	688	66	24	2.875	41.96	3.58
EVPFGT6630	763	794	66	30	2.875	50.19	4.40
EVPFGT6636	870	908	66	36	2.875	59.94	5.23
EVPFGT6642	984	1024	66	42	2.875	66.72	6.06
EVPFGT6648	1065	1113	66	48	2.875	74.11	6.88
EVPFGT6654	1226	1276	66	54	2.875	81.43	7.70
EVPFGT6660	1389	1445	66	60	2.875	88.69	8.53

EVFPFGT • Fabric Glazed Panel Premium - Tempered Glass

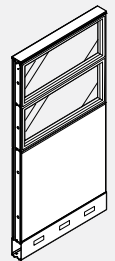

- Fabric Glazed Panel consists of individual fabric covered acoustic module in lower position with 2 or 3 glazed modules in upper position.
- Glazing is replaceable on site.

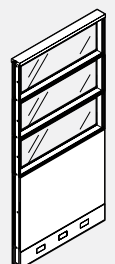

PRODUCT CODE	PRICE		SIZE/ INCHES			WEIGHT	VOL
	GR 1	GR 2	H	W	D	LBS	FT ³
EVFPFGT5418	542	553	54	18	2.875	32.95	2.19
EVFPFGT5424	652	668	54	24	2.875	40.16	2.06
EVFPFGT5430	726	749	54	30	2.875	47.89	2.58
EVFPFGT5436	809	831	54	36	2.875	55.14	3.09
EVFPFGT5442	898	929	54	42	2.875	60.82	3.61
EVFPFGT5448	988	1022	54	48	2.875	71.78	4.36
EVFPFGT5454	1107	1142	54	54	2.875	78.83	6.35
EVFPFGT5460	1224	1262	54	60	2.875	86.09	5.16
EVFPFGT6618	678	691	66	18	2.875	42.33	2.68
EVFPFGT6624	817	835	66	24	2.875	51.74	3.58
EVFPFGT6630	916	936	66	30	2.875	61.55	5.23
EVFPFGT6636	1011	1035	66	36	2.875	70.90	5.23
EVFPFGT6642	1128	1155	66	42	2.875	78.58	6.06
EVFPFGT6648	1241	1273	66	48	2.875	91.87	6.88
EVFPFGT6654	1405	1438	66	54	2.875	101.20	6.88
EVFPFGT6660	1568	1607	66	60	2.875	110.64	6.30

EVPFGTU • Fabric 12" Glazed Panel - Tempered Glass

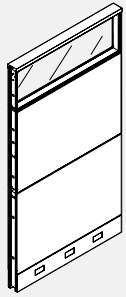

- Fabric 12" Glazed Panel incorporates one 12" glazed module and one 24" fabric modules above the 30" base section.
- Glazing is replaceable on site.

PRODUCT CODE	PRICE		SIZE/ INCHES			WEIGHT LBS	VOL FT ³
	GR 1	GR 2	H	W	D		
EVPFGTU6618	573	596	66	18	2.875	33.36	2.68
EVPFGTU6624	670	701	66	24	2.875	39.38	3.58
EVPFGTU6630	763	805	66	30	2.875	46.81	4.40
EVPFGTU6636	860	908	66	36	2.875	53.17	5.23
EVPFGTU6642	966	1022	66	42	2.875	58.45	6.06
EVPFGTU6648	1052	1113	66	48	2.875	68.56	6.88
EVPFGTU6654	1173	1239	66	54	2.875	75.28	7.70
EVPFGTU6660	1294	1369	66	60	2.875	81.95	8.53

EVFPFGTU • Fabric 12" Glazed Panel Premium - Tempered Glass

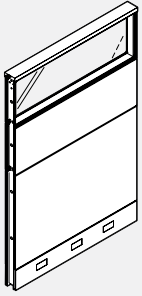

- Premium Fabric 12" Glazed Panel incorporates one 12" glazed module and 1 or 2 12" fabric module or 2 fabric modules above a 30" base section.
- Glazing is replaceable on site.

PRODUCT CODE	PRICE		SIZE/ INCHES			WEIGHT LBS	VOL FT ³
	GR 1	GR 2	H	W	D		
EVFPFGTU5418	524	546	54	18	2.875	29.56	2.19
EVFPFGTU5424	621	645	54	24	2.875	35.78	2.06
EVFPFGTU5430	699	731	54	30	2.875	42.61	2.58
EVFPFGTU5436	791	827	54	36	2.875	50.97	3.09
EVFPFGTU5442	886	929	54	42	2.875	56.65	3.61
EVFPFGTU5448	962	1007	54	48	2.875	63.16	4.36
EVFPFGTU5454	1079	1129	54	54	2.875	69.48	7.70
EVFPFGTU5460	1197	1255	54	60	2.875	75.75	5.16
EVFPFGTU6618	652	676	66	18	2.875	35.56	2.68
EVFPFGTU6624	761	794	66	24	2.875	42.98	3.58
EVFPFGTU6630	864	905	66	30	2.875	51.00	4.38
EVFPFGTU6636	973	1023	66	36	2.875	62.56	5.23
EVFPFGTU6642	1101	1155	66	42	2.875	70.25	6.06
EVFPFGTU6648	1188	1250	66	48	2.875	75.16	7.23
EVFPFGTU6654	1330	1401	66	54	2.875	82.50	7.70
EVFPFGTU6660	1475	1550	66	60	2.875	82.95	6.30

EVPMGTU • Monolithic 12" Glazed Panel - Tempered Glass

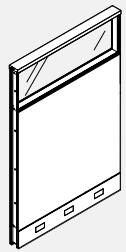

- Monolithic 12" Glazed Panel incorporates one 12" glazed module at the top of an otherwise Monolithic Panel.
- Glazing is replaceable on site.

PRODUCT CODE	PRICE		SIZE/ INCHES			WEIGHT LBS	VOL FT ³
	GR 1	GR 2	H	W	D		
EVPMGTU4818	495	521	48	18	2.875	26.96	1.92
EVPMGTU4824	580	618	48	24	2.875	31.98	2.62
EVPMGTU4830	674	718	48	30	2.875	37.62	3.23
EVPMGTU4836	773	829	48	36	2.875	42.77	3.85
EVPMGTU4842	856	914	48	42	2.875	46.45	4.45
EVPMGTU4848	932	1000	48	48	2.875	54.45	5.06
EVPMGTU4854	1035	1106	48	54	2.875	59.87	5.66
EVPMGTU4860	1135	1220	48	60	2.875	67.15	6.27
EVPMGTU5418	510	542	54	18	2.875	29.56	2.19
EVPMGTU5424	593	633	54	24	2.875	34.58	2.94
EVPMGTU5430	678	755	54	30	2.875	40.22	3.62
EVPMGTU5436	755	859	54	36	2.875	45.37	4.31
EVPMGTU5442	845	897	54	42	2.875	49.05	4.99
EVPMGTU5448	932	1059	54	48	2.875	57.16	5.67
EVPMGTU5454	1020	1162	54	54	2.875	62.47	6.32
EVPMGTU5460	1108	1268	54	60	2.875	67.55	7.03
EVPMGTU6618	547	578	66	18	2.875	33.96	2.68
EVPMGTU6624	656	697	66	24	2.875	38.98	3.58
EVPMGTU6630	755	800	66	30	2.875	44.62	4.40
EVPMGTU6636	836	888	66	36	2.875	49.77	5.23
EVPMGTU6642	930	992	66	42	2.875	53.45	6.06
EVPMGTU6648	1027	1096	66	48	2.875	61.16	6.88
EVPMGTU6654	1126	1201	66	54	2.875	66.87	6.88
EVPMGTU6660	1222	1307	66	60	2.875	71.95	8.53

EVPFGTX • Fabric 36" Glazed Panel - Tempered Glass

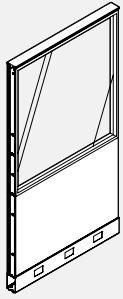

- Fabric 36" Glazed Panel incorporates one 36" glazed module above the 30" base section.
- Glazing is replaceable on site.

PRODUCT CODE	PRICE		SIZE/ INCHES			WEIGHT LBS	VOL FT ³
	GR 1	GR 2	H	W	D		
EVPFGTX6618	658	672	66	18	2.875	35.45	4.23
EVPFGTX6624	727	747	66	24	2.875	42.54	5.23
EVPFGTX6630	845	864	66	30	2.875	50.15	6.23
EVPFGTX6636	960	985	66	36	2.875	57.26	6.23
EVPFGTX6642	1074	1102	66	42	2.875	63.02	6.56
EVPFGTX6648	1175	1208	66	48	2.875	72.99	6.88
EVPFGTX6654	1294	1328	66	54	2.875	80.28	7.70
EVPFGTX6660	1411	1448	66	60	2.875	87.32	8.53

EVPXGT • Fully Glazed Monolithic Panel - Tempered Glass

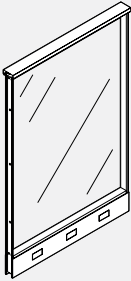

- Fully Glazed Monolithic Panel incorporates one glazed module into a rigid steel frame.
- Glazing is replaceable on site.

PRODUCT CODE	PRICE		SIZE/ INCHES			WEIGHT LBS	VOL FT ³
	H	W	D	LBS	FT ³		
EVPXGT4218	463	42	18	2.875	26.05	1.71	
EVPXGT4224	510	42	24	2.875	32.14	2.31	
EVPXGT4230	593	42	30	2.875	37.96	3.11	
EVPXGT4236	670	42	36	2.875	43.86	3.46	
EVPXGT4242	745	42	42	2.875	48.02	4.46	
EVPXGT4818	411	48	18	2.875	29.02	1.92	
EVPXGT4824	529	48	24	2.875	35.61	2.62	
EVPXGT4830	587	48	30	2.875	41.93	3.23	
EVPXGT4836	724	48	36	2.875	48.33	3.85	
EVPXGT4842	760	48	42	2.875	52.98	4.45	
EVPXGT5418	516	54	18	2.875	31.60	2.19	
EVPXGT5424	605	54	24	2.875	37.60	2.58	
EVPXGT5430	702	54	30	2.875	45.48	3.29	
EVPXGT5436	790	54	36	2.875	52.39	4.58	
EVPXGT5442	880	54	42	2.875	57.54	5.58	
EVPXGT6618	604	66	18	2.875	37.54	2.68	
EVPXGT6624	700	66	24	2.875	45.61	3.58	
EVPXGT6630	810	66	30	2.875	53.43	3.99	
EVPXGT6636	909	66	36	2.875	61.32	4.58	
EVPXGT6642	1013	66	42	2.875	67.46	5.58	

EVPGPT • Fully Glazed Premium Panel - Tempered Glass

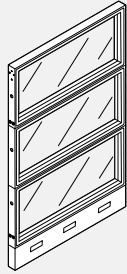

- Fully Glazed Premium Panel incorporates all 12" glazed modules above the 6" base raceway channel.
- Glazing is replaceable on site.

PRODUCT CODE	PRICE		SIZE/ INCHES			WEIGHT LBS	VOL FT ³
	H	W	D	LBS	FT ³		
EVPGPT4218	608	42	18	2.875	32.13	1.71	
EVPGPT4224	744	42	24	2.875	39.74	2.31	
EVPGPT4230	826	42	30	2.875	47.56	2.85	
EVPGPT4236	898	42	36	2.875	50.90	3.38	
EVPGPT4242	999	42	42	2.875	54.98	3.92	
EVPGPT4248	1109	42	48	2.875	72.27	4.45	
EVPGPT4254	1225	42	54	2.875	70.89	4.98	
EVPGPT4260	1333	42	60	2.875	87.44	5.52	
EVPGPT5418	773	54	18	2.875	35.19	2.19	
EVPGPT5424	949	54	24	2.875	49.76	2.58	
EVPGPT5430	1050	54	30	2.875	52.08	3.62	
EVPGPT5436	1142	54	36	2.875	64.54	4.31	
EVPGPT5442	1267	54	42	2.875	72.62	4.99	
EVPGPT5448	1415	54	48	2.875	78.11	5.67	
EVPGPT5454	1560	54	54	2.875	86.04	6.35	
EVPGPT5460	1700	54	60	2.875	94.09	7.03	
EVPGPT6618	936	66	18	2.875	41.15	2.68	
EVPGPT6624	1148	66	24	2.875	50.96	3.58	
EVPGPT6630	1269	66	30	2.875	60.47	3.58	
EVPGPT6636	1385	66	36	2.875	76.14	4.58	
EVPGPT6642	1539	66	42	2.875	86.22	6.06	
EVPGPT6648	1714	66	48	2.875	90.11	6.88	
EVPGPT6654	1891	66	54	2.875	99.05	7.70	
EVPGPT6660	2063	66	60	2.875	108.29	8.53	

EVPGT • Fully Glazed Panel - Tempered Glass

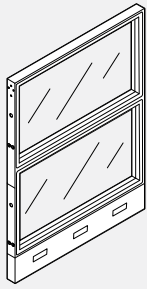

- 54" H Fully Glazed Panels incorporates two 24" Glazed modules.
- Stackability: Evolve Panels can be increased in height in 6", 12" or 24" increments.
- See Extension Module listings for part numbers.
- Standard in clear (CLR)
- Frosted Glass (FRST) upcharge varies. Contact EVOLVE Customer Support for details.
- Glazing is replaceable on site.

PRODUCT CODE	PRICE	SIZE/ INCHES			WEIGHT LBS	VOL FT³
		H	W	D		
EVPGT5418	619	54	18	2.875	35.19	2.19
EVPGT5424	758	54	24	2.875	49.76	2.58
EVPGT5430	837	54	30	2.875	52.08	3.62
EVPGT5436	916	54	36	2.875	64.54	4.31
EVPGT5442	1016	54	42	2.875	72.62	4.99
EVPGT5448	1132	54	48	2.875	78.11	5.67
EVPGT5454	1245	54	54	2.875	86.04	6.35
EVPGT5460	1360	54	60	2.875	94.09	7.03

EVPFOL • Open Bottom Panel

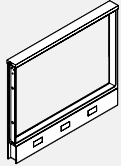

- Open Bottom Panel incorporates a 24" opening in the base section to provide maximum air circulation and access to electrical or data panels.

PRODUCT CODE	PRICE		SIZE/ INCHES			WEIGHT LBS	VOL FT³
	GR 1	GR 2	H	W	D		
EVPFOL3018	236	-	30	18	2.875	17.08	1.23
EVPFOL3024	270	-	30	24	2.875	19.20	1.63
EVPFOL3030	306	-	30	30	2.875	23.05	2.00
EVPFOL3036	339	-	30	36	2.875	25.80	2.38
EVPFOL3042	371	-	30	42	2.875	27.99	2.76
EVPFOL3048	399	-	30	48	2.875	34.00	3.13
EVPFOL3054	433	-	30	54	2.875	37.71	3.51
EVPFOL3060	464	-	30	60	2.875	41.00	3.89
EVPFOL4218	354	365	42	18	2.875	22.28	1.71
EVPFOL4224	409	418	42	24	2.875	25.60	2.31
EVPFOL4230	464	476	42	30	2.875	30.65	2.85
EVPFOL4236	520	535	42	36	2.875	36.60	3.38
EVPFOL4242	579	592	42	42	2.875	40.79	3.92
EVPFOL4248	625	639	42	48	2.875	45.20	4.45
EVPFOL4254	687	705	42	54	2.875	49.92	4.98
EVPFOL4260	744	761	42	60	2.875	54.40	5.52
EVPFOL5418	404	417	54	18	2.875	25.68	2.19
EVPFOL5424	460	478	54	24	2.875	28.80	2.94
EVPFOL5430	524	546	54	30	2.875	34.45	3.24
EVPFOL5436	591	614	54	36	2.875	38.40	4.31
EVPFOL5442	658	687	54	42	2.875	42.19	4.99
EVPFOL5448	712	744	54	48	2.875	50.20	5.67
EVPFOL5454	780	814	54	54	2.875	55.32	6.35
EVPFOL5460	846	884	54	60	2.875	60.20	7.03
EVPFOL6618	523	544	66	18	2.875	31.68	2.68
EVPFOL6624	603	627	66	24	2.875	36.00	3.58
EVPFOL6630	691	721	66	30	2.875	42.84	4.40
EVPFOL6636	775	811	66	36	2.875	50.00	5.23
EVPFOL6642	870	913	66	42	2.875	55.79	6.06
EVPFOL6648	936	984	66	48	2.875	62.20	6.88
EVPFOL6654	1033	1086	66	54	2.875	68.33	7.70
EVPFOL6660	1128	1186	66	60	2.875	74.40	8.53

EVPFPOL • Open Bottom Panel Premium

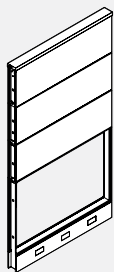

- Open Bottom Premium Panel incorporates a 24" opening in the base section to provide maximum air circulation and access to electrical or data panels.
- 12" high acoustic modules incorporated above the 30" base section.

PRODUCT CODE	PRICE		SIZE/ INCHES			WEIGHT LBS	VOL FT³
	GR 1	GR 2	H	W	D		
EVPFPOL5418	476	487	54	18	2.875	27.88	2.19
EVPFPOL5424	548	568	54	24	2.875	32.40	2.94
EVPFPOL5430	626	647	54	30	2.875	38.64	3.24
EVPFPOL5436	701	725	54	36	2.875	47.80	4.31
EVPFPOL5442	792	820	54	42	2.875	53.99	4.99
EVPFPOL5448	850	882	54	48	2.875	56.80	5.67
EVPFPOL5454	937	972	54	54	2.875	62.53	6.35
EVPFPOL5460	1024	1062	54	60	2.875	68.20	7.03
EVPFPOL6618	596	615	66	18	2.875	33.88	1.84
EVPFPOL6624	692	718	66	24	2.875	39.60	2.52
EVPFPOL6630	786	819	66	30	2.875	47.03	3.15
EVPFPOL6636	888	925	66	36	2.875	59.40	5.23
EVPFPOL6642	1001	1043	66	42	2.875	67.59	4.41
EVPFPOL6648	1073	1121	66	48	2.875	68.80	6.06
EVPFPOL6654	1194	1243	66	54	2.875	75.54	7.70
EVPFPOL6660	1304	1362	66	60	2.875	82.40	6.30

EVVFO • Fabric Open Panel 12" Opening

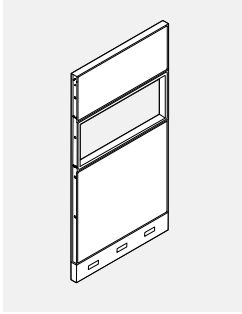

- Fabric Open Panel incorporates a 12" opening above the 30" base section to provide pass-through convenience.

PRODUCT CODE	PRICE		SIZE/ INCHES			WEIGHT	VOL
	GR 1	GR 2	H	W	D	LBS	FT ³
EVVFO5418	484	505	54	18	2.875	26.58	2.19
EVVFO5424	563	589	54	24	2.875	31.80	2.94
EVVFO5430	653	682	54	30	2.875	37.64	3.38
EVVFO5436	736	774	54	36	2.875	45.00	4.31
EVVFO5442	830	870	54	42	2.875	49.69	4.99
EVVFO5448	895	942	54	48	2.875	55.20	5.67
EVVFO5454	994	1043	54	54	2.875	60.53	6.35
EVVFO5460	1089	1146	54	60	2.875	65.80	7.03
EVVFO6618	536	561	66	18	2.875	30.38	2.68
EVVFO6624	619	653	66	24	2.875	35.40	3.58
EVVFO6630	709	748	66	30	2.875	41.84	5.86
EVVFO6636	809	856	66	36	2.875	47.20	5.23
EVVFO6642	909	963	66	42	2.875	51.49	6.06
EVVFO6648	985	1046	66	48	2.875	60.60	6.88
EVVFO6654	1090	1157	66	54	2.875	66.33	7.70
EVVFO6660	1196	1269	66	60	2.875	72.00	8.53

EVVFO • Fabric Open Premium Panel 12" Opening

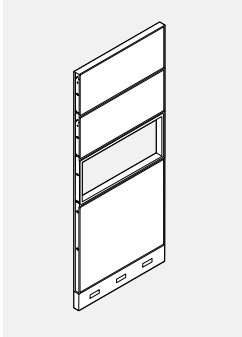

- Fabric Open Premium Panel incorporates a 12" opening above the 30" base section to provide pass-through convenience.
- Two 12" fabric acoustic modules are placed above the 12" opening.

PRODUCT CODE	PRICE		SIZE/ INCHES			WEIGHT	VOL
	GR 1	GR 2	H	W	D	LBS	FT ³
EVVFO6618	607	631	66	18	2.875	32.58	1.84
EVVFO6624	701	736	66	24	2.875	39.00	3.58
EVVFO6630	811	851	66	30	2.875	46.03	4.47
EVVFO6636	917	963	66	36	2.875	56.60	5.23
EVVFO6642	1041	1095	66	42	2.875	63.29	6.06
EVVFO6648	1122	1182	66	48	2.875	67.20	6.88
EVVFO6654	1245	1315	66	54	2.875	73.54	7.70
EVVFO6660	1369	1443	66	60	2.875	80.00	8.53

EVVFOX • Fabric Open Premium Panel 24" Opening

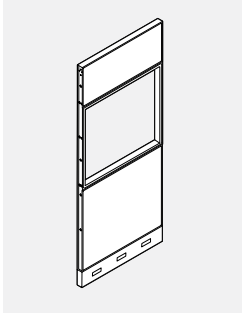

- Fabric Open Premium Panel incorporates a 24" opening above the 30" base section to provide pass-through convenience.
- May or may not have a 12" fabric acoustic module above the 24" opening.

PRODUCT CODE	PRICE		SIZE/ INCHES			WEIGHT	VOL
	GR 1	GR 2	H	W	D	LBS	FT ³
EVVFOX5418	404	417	54	18	2.875	25.68	2.19
EVVFOX5424	460	478	54	24	2.875	28.80	2.94
EVVFOX5430	524	546	54	30	2.875	34.45	3.38
EVVFOX5436	591	614	54	36	2.875	38.40	4.31
EVVFOX5442	657	686	54	42	2.875	42.19	4.99
EVVFOX5448	709	740	54	48	2.875	50.20	5.67
EVVFOX5454	779	813	54	54	2.875	55.32	6.35
EVVFOX5460	846	884	54	60	2.875	60.20	7.03
EVVFOX6618	523	544	66	18	2.875	31.68	2.68
EVVFOX6624	603	627	66	24	2.875	36.00	3.58
EVVFOX6630	709	737	66	30	2.875	42.84	5.86
EVVFOX6636	775	811	66	36	2.875	50.00	5.23
EVVFOX6642	870	913	66	42	2.875	55.79	6.06
EVVFOX6648	936	984	66	48	2.875	62.20	6.88
EVVFOX6654	1033	1086	66	54	2.875	68.33	7.70
EVVFOX6660	1128	1186	66	60	2.875	74.40	8.53

EVPFSG5M66 - Reception Panels, 24" Fabric Bottom Module and 6" Pass Thru

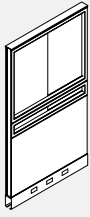

- Reception panel incorporates glazed tempered glass module and pass thru module within steel frame.
- 6" pass thru with sliding tempered glass door module.
- 24" fabric bottom module.
- Aluminum low profile top is included.
- Stackability: Evolve panels can be increased in height in 6", 12", 24" increments. See module listing for part numbers.

PRODUCT CODE	PRICE	SIZE/ INCHES			WEIGHT LBS	VOL FT ³
		H	W	D		
EVPFSG5M6636	1016	66	36	2.875	70.9	5.23
EVPFSG5M6642	1131	66	42	2.875	78.58	6.06
EVPFSG5M6648	1244	66	48	2.875	91.87	6.88

EVPFSG3M66 - Reception Panels, 30" Fabric Bottom Module and 6" Pass Thru

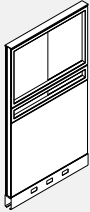

- Reception panel incorporates glazed tempered glass module and pass thru module within steel frame.
- 6" pass thru with sliding tempered glass door module.
- 30" fabric bottom module.
- Aluminum low profile top is included.
- Stackability: Evolve panels can be increased in height in 6", 12", 24" increments. See module listing for part numbers.

PRODUCT CODE	PRICE	SIZE/ INCHES			WEIGHT LBS	VOL FT ³
		H	W	D		
EVPFSG3M6636	1053	66	36	2.875	70.9	5.23
EVPFSG3M6642	1148	66	42	2.875	78.58	6.06
EVPFSG3M6648	1246	66	48	2.875	91.87	6.88

EVPFSG2M66 - Reception Panels, 24" Fabric Bottom Module and 12" Pass Thru

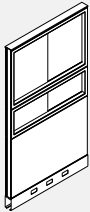

- Reception panel incorporates glazed tempered glass module and pass thru module within steel frame.
- 12" pass thru with sliding tempered glass door module.
- 24" fabric bottom module.
- Aluminum low profile top is included.
- Stackability: Evolve panels can be increased in height in 6", 12", 24" increments. See module listing for part numbers.

PRODUCT CODE	PRICE	SIZE/ INCHES			WEIGHT LBS	VOL FT ³
		H	W	D		
EVPFSG2M6636	998	66	36	2.875	70.9	5.23
EVPFSG2M6642	1100	66	42	2.875	78.58	6.06
EVPFSG2M6648	1211	66	48	2.875	91.87	6.88

EVPHSG5M66 - Reception Panels, 24" Laminate Bottom Module and 6" Pass Thru

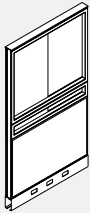

- Reception panel incorporates glazed tempered glass module and pass thru module within steel frame.
- 6" pass thru with sliding tempered glass door module.
- 24" laminate bottom module.
- Aluminum low profile top is included.
- Stackability: Evolve panels can be increased in height in 6", 12", 24" increments. See module listing for part numbers.

PRODUCT CODE	PRICE	SIZE/ INCHES			WEIGHT LBS	VOL FT ³
		H	W	D		
EVPHSG5M6636	1137	66	36	2.875	70.9	5.23
EVPHSG5M6642	1233	66	42	2.875	78.58	6.06
EVPHSG5M6648	1328	66	48	2.875	91.87	6.88

EVPHSG3M66 - Reception Panels, 30" Laminate Bottom Module and 6" Pass Thru

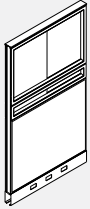

- Reception panel incorporates glazed tempered glass module and pass thru module within steel frame.
- 6" pass thru with sliding tempered glass door module.
- 30" laminate bottom module.
- Aluminum low profile top is included.
- Stackability: Evolve panels can be increased in height in 6", 12", 24" increments. See module listing for part numbers.

PRODUCT CODE	PRICE	SIZE/ INCHES			WEIGHT LBS	VOL FT ³
		H	W	D		
EVPHSG3M6636	1137	66	36	2.875	70.9	5.23
EVPHSG3M6642	1233	66	42	2.875	78.58	6.06
EVPHSG3M6648	1328	66	48	2.875	91.87	6.88

EVPHSG2M66 - Reception Panels, 24" Laminate Bottom Module and 12" Pass Thru

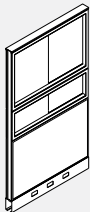

- Reception panel incorporates glazed tempered glass module and pass thru module within steel frame.
- 12" pass thru with sliding tempered glass door module.
- 24" laminate bottom module.
- Aluminum low profile top is included.
- Stackability: Evolve panels can be increased in height in 6", 12", 24" increments. See module listing for part numbers.

PRODUCT CODE	PRICE	SIZE/ INCHES			WEIGHT LBS	VOL FT ³
		H	W	D		
EVPHSG2M6636	1112	66	36	2.875	70.9	5.23
EVPHSG2M6642	1204	66	42	2.875	78.58	6.06
EVPHSG2M6648	1302	66	48	2.875	91.87	6.88

EVPPFAF • Air Flow Panel

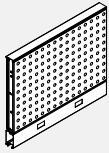

- Metal Air Flow Panel.
- Stackability: Evolve panels can be increased in height in 6", 12", 24" increments. See module listing for part numbers.

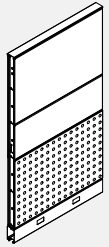
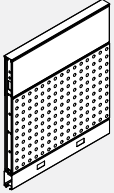

PRODUCT CODE	PRICE		SIZE/ INCHES			WEIGHT LBS	VOL FT ³
	GR 1	GR 2	H	W	D		
EVPPFAF3024	399	-	30	24	2.875	22.08	1.63
EVPPFAF3030	475	-	30	30	2.875	26.51	2.00
EVPPFAF3036	524	-	30	36	2.875	29.67	2.38
EVPPFAF3042	581	-	30	42	2.875	32.19	2.76
EVPPFAF3048	657	-	30	48	2.875	39.10	3.13
EVPPFAF3054	755	-	30	54	2.875	43.37	3.51
EVPPFAF3060	852	-	30	60	2.875	47.15	3.89
EVPPFAF4224	509	517	42	24	2.875	29.44	2.31
EVPPFAF4230	603	612	42	30	2.875	35.25	2.81
EVPPFAF4236	670	682	42	36	2.875	42.09	3.38
EVPPFAF4242	746	758	42	42	2.875	46.91	3.92
EVPPFAF4248	842	856	42	48	2.875	51.98	4.45
EVPPFAF4254	958	975	42	54	2.875	57.41	4.98
EVPPFAF4260	972	994	42	60	2.875	62.56	5.52
EVPPFAF5424	570	586	54	24	2.875	33.12	2.94
EVPPFAF5430	656	676	54	30	2.875	39.62	3.62
EVPPFAF5436	736	759	54	36	2.875	44.16	4.31
EVPPFAF5442	820	849	54	42	2.875	48.52	4.99
EVPPFAF5448	921	954	54	48	2.875	57.73	5.67
EVPPFAF5454	1073	1108	54	54	2.875	63.62	6.35
EVPPFAF5460	1169	1205	54	60	2.875	69.23	7.03
EVPPFAF6624	665	691	66	24	2.875	41.40	3.58
EVPPFAF6630	785	816	66	30	2.875	49.27	4.40
EVPPFAF6636	882	917	66	36	2.875	57.50	5.23
EVPPFAF6642	983	1023	66	42	2.875	64.16	6.06
EVPPFAF6648	1106	1153	66	48	2.875	71.53	6.08
EVPPFAF6654	1255	1303	66	54	2.875	78.58	7.70
EVPPFAF6660	1391	1447	66	60	2.875	85.56	8.53

EVPPPAF • Premium Air Flow Panel

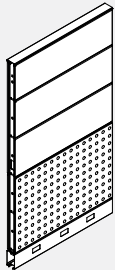

- Metal Air Flow Panel.
- Each side of panel may have different fabric within same grade at no upcharge.
- There is no panel creep.
- Stackability: Evolve panels can be increased in height in 6", 12", 24" increments. See module listing for part numbers.

PRODUCT CODE	PRICE		SIZE/ INCHES			WEIGHT LBS	VOL FT ³
	GR 1	GR 2	H	W	D		
EVPPPAF5424	633	653	54	24	2.875	37.26	2.94
EVPPPAF5430	724	747	54	30	2.875	44.44	3.62
EVPPPAF5436	814	839	54	36	2.875	54.97	4.31
EVPPPAF5442	903	930	54	42	2.875	62.09	4.99
EVPPPAF5448	1023	1055	54	48	2.875	65.32	5.67
EVPPPAF5454	1157	1194	54	54	2.875	73.06	6.35
EVPPPAF5460	1294	1330	54	60	2.875	78.43	7.03
EVPPPAF6624	725	752	66	24	2.875	45.54	3.58
EVPPPAF6630	853	885	66	30	2.875	54.08	4.40
EVPPPAF6636	956	994	66	36	2.875	68.31	5.23
EVPPPAF6642	1062	1102	66	42	2.875	77.73	6.06
EVPPPAF6648	1205	1255	66	48	2.875	79.12	6.08
EVPPPAF6654	1358	1409	66	54	2.875	86.87	7.70
EVPPPAF6660	1514	1570	66	60	2.875	94.76	8.53

EVPPMAF • Premium Air Flow Panel

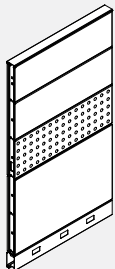

- Metal Air Flow Panel.
- Each side of panel may have different fabric within same grade at no upcharge.
- There is no panel creep.
- Stackability: Evolve panels can be increased in height in 6", 12", 24" increments. See module listing for part numbers.

PRODUCT CODE	PRICE		SIZE/ INCHES			WEIGHT LBS	VOL FT ³
	GR 1	GR 2	H	W	D		
EVPPMAF5424	695	722	54	24	2.875	36.57	2.94
EVPPMAF5430	825	854	54	30	2.875	43.29	3.62
EVPPMAF5436	937	973	54	36	2.875	51.75	4.31
EVPPMAF5442	1055	1094	54	42	2.875	57.14	4.99
EVPPMAF5448	1175	1224	54	48	2.875	63.48	5.67
EVPPMAF5454	1330	1382	54	54	2.875	69.61	6.35
EVPPMAF5460	1484	1542	54	60	2.875	75.67	7.03
EVPPMAF6624	791	825	66	24	2.875	44.85	3.58
EVPPMAF6630	935	975	66	30	2.875	52.93	4.40
EVPPMAF6636	1063	1112	66	36	2.875	65.09	5.23
EVPPMAF6642	1193	1244	66	42	2.875	72.78	6.06
EVPPMAF6648	1330	1394	66	48	2.875	77.28	6.08
EVPPMAF6654	1500	1568	66	54	2.875	84.58	7.70
EVPPMAF6660	1669	1745	66	60	2.875	92.00	8.53

EVPDS • Door Panel - Solid

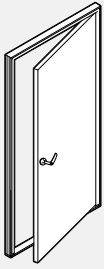

- 90° Door Panel height = 66" high panel plus one 24" or two 12" Panel Extension Modules.
- 1 3/8" thick hollow core door.
- Handedness can be changed in the field.
- Handle sold separately. Specify type of handle required.

PRODUCT CODE	PRICE	SIZE/ INCHES			WEIGHT LBS	VOL FT ³
		H	W	D		
EVPDS7836L	2356	78	36	2.875	64.00	7.50
EVPDS7836R	2356	78	36	2.875	64.00	7.50
EVPDS7842L	2740	78	42	2.875	74.00	8.50
EVPDS7842R	2740	78	42	2.875	74.00	8.50
EVPDS8436L	2480	84	36	2.875	62.00	7.00
EVPDS8436R	2480	84	36	2.875	62.00	7.00
EVPDS8442L	2871	84	42	2.875	72.00	8.00
EVPDS8442R	2871	84	42	2.875	72.00	8.00
EVPDS9036L	2490	90	36	2.875	66.00	8.00
EVPDS9036R	2490	90	36	2.875	66.00	8.00
EVPDS9042L	2871	90	42	2.875	76.00	9.00
EVPDS9042R	2871	90	42	2.875	76.00	9.00

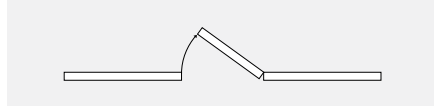

RIGHT HAND HUNG

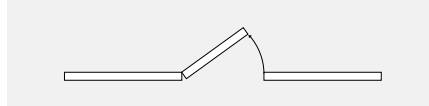

LEFT HAND HUNG

EVPDG • Full Glazed Door panel

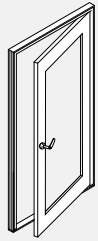

- All door surfaces are high pressure laminate with window.
- If laminate is selected in wood grain, the grain runs vertical.
- HP laminate finish available in all standard finishes.
- Select frame color from standard trim colors.
- 84" Door panel height is 66"h panel and 18" H Panel extension modules.
- 90" Door panel height is 66"h panel and 24" H or two 12" H Panel extension modules.
- Door and door trim can be specified left or right handed.
- Handedness of Door can be changed in field.
- Door Sizes:
 - 36" W door is 33.63" W without frame (This door is not ADA compliant)
 - 42" W door is 39.63" W without frame
 - 84" H door is 81.50" H without frame
 - 90" H door is 87.50" H without frame
- Customer is responsible to confirm and meet, city, county or any other municipality codes in relation to door clearances.
- Knob or lever to be ordered separately.

PRODUCT CODE	PRICE CLR	FRST	SIZE/INCHES			WEIGHT LBS	VOL FT ³
			H	W	D		
EVPDG8436L	2762	2862	84	36	2.875	62	7
EVPDG8436R	2762	2862	84	36	2.875	62	7
EVPDG8442L	3146	3243	84	42	2.875	72	8
EVPDG8442R	3146	3243	84	42	2.875	72	8
EVPDG9036L	2762	2862	90	36	2.875	66	8
EVPDG9036R	2762	2862	90	36	2.875	66	8
EVPDG9042L	3146	3243	90	42	2.875	76	9
EVPDG9042R	3146	3243	90	42	2.875	76	9

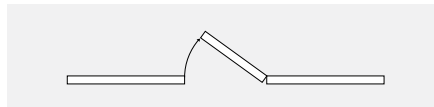

RIGHT HAND HUNG

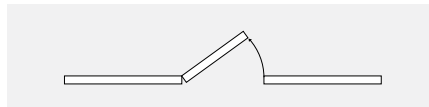

LEFT HAND HUNG

EVPDSL • Door Handles

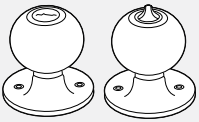

EVPDSL01

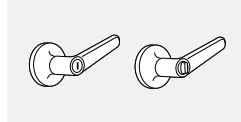

EVPDSL02

PRODUCT CODE	PRICE	SIZE/ INCHES			WEIGHT LBS	VOL FT ³
		H	W	D		
EVPDSL01	90				0.50	0.50
EVPDSL02	127				0.30	0.10

EVPDSL • Sliding Door

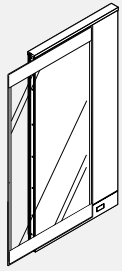

- Provides territorial privacy in an open plan environment.
- Lightweight, panel mounted sliding partition.
- Consists of translucent textured polycarbonate.
- Must be mounted to a panel of the same size.
- The face of the Privacy Screen sits 3" away from the face of the panel to which it is attached.
- When open, the screen may interfere with raceway doors that open on the outside of an adjacent panel.
- Must specify left or right for the direction in which the door will slide once installed.
- Caps located on the end of the frame default to the panel frame colour.
- All hardware included.

• Note: Specify left or right for the direction in which the door will slide as per examples above.

PRODUCT CODE	PRICE	SIZE/ INCHES			WEIGHT VOL	
		H	W	D	LBS	FT ³
EVPDSL6636R	1981	66	36	2.61	35	5.98
EVPDSL6636L	1981	66	36	2.61	35	5.98
EVPDSL6642R	2132	66	42	2.61	42	6.93
EVPDSL6642L	2132	66	42	2.61	42	6.93
EVPDSL8136R	2377	81	36	2.61	43	7.30
EVPDSL8136L	2377	81	36	2.61	43	7.30
EVPDSL8142R	2551	81	42	2.61	50	8.45
EVPDSL8142L	2551	81	42	2.61	50	8.45

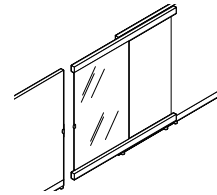

Left Hand Option

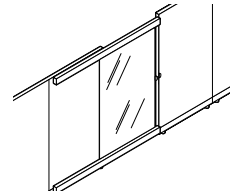

Right Hand Option

EVPDSLLOCK • Sliding Door Lock

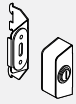

Left Hand Shown

- Lock bracket attaches to Sliding door with screws
- Includes strike plate bracket which attaches to slots in connector.
- Lock included.
- Available in tungsten only.

PRODUCT CODE	PRICE	SIZE/INCHES			WEIGHT VOL	
		H	W	D	LBS	FT ³
EVPDSLLOCKR	240	2.65	1.2	0.9	1.0	0.2
EVPDSLLOCKL	240	2.65	1.2	0.9	1.0	0.2

EVAFMB01 • Floor Mount Plate

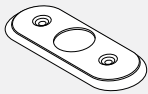

- Attached to floor.
- Secures panel to floor.
- Attachment screws not included.
- Care should be taken to use correct fasteners for type of floor.
- Available in chrome finish only.

PRODUCT CODE	PRICE	SIZE/ INCHES			WEIGHT VOL	
		H	W	D	LBS	FT ³
EVAFMB01	72	0.25	5	2.5	0.2	0.02

EVPFE • Panel Extension Module

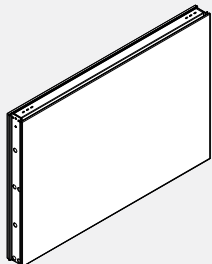

- Single modules are 6", 12", 18" or 24" high.
- When ordering Panel Extension Module, additional connectors are required.

PRODUCT CODE	PRICE		SIZE/ INCHES			WEIGHT VOL	
	GR 1	GR 2	H	W	D	LBS	FT ³
EVPFE0618	153	160	6	18	2.875	4.80	0.21
EVPFE0624	159	169	6	24	2.875	6.40	0.29
EVPFE0630	174	183	6	30	2.875	7.40	0.36
EVPFE0636	195	207	6	36	2.875	8.20	0.43
EVPFE0642	217	233	6	42	2.875	9.40	0.51
EVPFE0648	235	248	6	48	2.875	10.20	0.58
EVPFE0654	253	271	6	54	2.875	14.40	0.65
EVPFE0660	276	295	6	60	2.875	16.00	0.73
EVPFE1218	153	160	12	18	2.875	7.40	0.38
EVPFE1224	159	168	12	24	2.875	8.60	0.50
EVPFE1230	174	183	12	30	2.875	9.60	0.63
EVPFE1236	195	207	12	36	2.875	12.80	0.75
EVPFE1242	217	231	12	42	2.875	14.80	0.88
EVPFE1248	235	248	12	48	2.875	15.00	1.00
EVPFE1254	253	271	12	54	2.875	16.20	1.12
EVPFE1260	276	295	12	60	2.875	17.80	1.25
EVPFE1818	190	201	18	18	2.875	9.01	0.54
EVPFE1824	197	211	18	24	2.875	10.47	0.72
EVPFE1830	212	234	18	30	2.875	11.93	0.90
EVPFE1836	246	268	18	36	2.875	13.39	1.08
EVPFE1842	274	301	18	42	2.875	14.84	1.26
EVPFE1848	298	328	18	48	2.875	16.29	1.44
EVPFE1854	324	355	18	54	2.875	17.76	1.62
EVPFE1860	352	382	18	60	2.875	19.21	1.80
EVPFE2418	190	201	24	18	2.875	10.60	0.75
EVPFE2424	197	212	24	24	2.875	12.32	1.00
EVPFE2430	212	234	24	30	2.875	14.03	1.25
EVPFE2436	246	268	24	36	2.875	15.75	1.50
EVPFE2442	274	301	24	42	2.875	17.46	1.75
EVPFE2448	298	328	24	48	2.875	19.17	2.00
EVPFE2454	324	355	24	54	2.875	20.89	2.25
EVPFE2460	352	391	24	60	2.875	22.60	2.50

EVPFPE • Panel Extension Module Premium

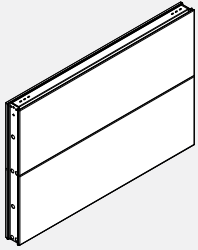

- Two 12" modules are incorporated into one 24" high metal frame.
- When ordering Panel Extension Module, additional connectors are required.

PRODUCT CODE	PRICE		SIZE/ INCHES			WEIGHT		VOL FT ³
	GR 1	GR 2	H	W	D	LBS		
EVPFPE2418	260	270	24	18	2.875	13.90	1.02	
EVPFPE2424	276	293	24	24	2.875	16.80	1.42	
EVPFPE2430	307	328	24	30	2.875	19.58	1.75	
EVPFPE2436	350	373	24	36	2.875	26.40	2.07	
EVPFPE2442	391	418	24	42	2.875	31.04	2.40	
EVPFPE2448	419	450	24	48	2.875	38.40	2.73	
EVPFPE2454	464	499	24	54	2.875	30.90	2.25	
EVPFPE2460	508	544	24	60	2.875	34.00	3.39	

EVPW1SE • Writeboard Extension Module - One Side

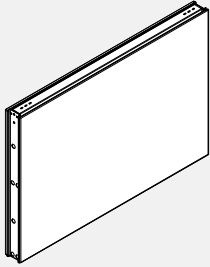

- Single 18" or 24" high module with Writeboard on one side and fabric on the other side.
- Use of erasable Writeboard markers only.
- When ordering Panel Extension Module, additional connectors are required.

PRODUCT CODE	PRICE		SIZE/ INCHES			WEIGHT		VOL FT ³
	GR 1	GR 2	H	W	D	LBS		
EVPW1SE0618	212	217	06	18	3	2.77	0.25	
EVPW1SE0624	247	259	06	24	3	3.20	0.35	
EVPW1SE0630	280	284	06	30	3	3.63	0.43	
EVPW1SE0636	319	327	06	36	3	4.06	0.51	
EVPW1SE0642	361	367	06	42	3	4.49	0.60	
EVPW1SE0648	394	404	06	48	3	4.91	0.68	
EVPW1SE0654	446	454	06	54	3	5.34	0.76	
EVPW1SE0660	469	477	06	60	3	5.77	0.84	
EVPW1SE0666	488	500	06	66	3	6.17	0.91	
EVPW1SE0672	542	550	06	72	3	6.57	0.99	
EVPW1SE1218	212	217	12	18	3	5.55	0.51	
EVPW1SE1224	247	259	12	24	3	6.41	0.71	
EVPW1SE1230	280	284	12	30	3	7.26	0.87	
EVPW1SE1236	319	327	12	36	3	8.12	1.03	
EVPW1SE1242	361	367	12	42	3	8.98	1.20	
EVPW1SE1248	394	404	12	48	3	9.83	1.36	
EVPW1SE1254	446	454	12	54	3	10.69	1.53	
EVPW1SE1260	469	477	12	60	3	11.55	1.69	
EVPW1SE1266	488	500	12	66	3	12.41	1.85	
EVPW1SE1272	542	550	12	72	3	13.27	1.99	
EVPW1SE1818	233	237	18	18	2.875	9.44	0.54	
EVPW1SE1824	263	270	18	24	2.875	10.90	0.72	
EVPW1SE1830	293	303	18	30	2.875	12.35	0.90	
EVPW1SE1836	344	355	18	36	2.875	13.81	1.08	
EVPW1SE1842	389	405	18	42	2.875	15.27	1.26	
EVPW1SE1848	430	448	18	48	2.875	16.72	1.44	
EVPW1SE1854	465	483	18	54	2.875	18.18	1.62	
EVPW1SE1860	503	520	18	60	2.875	19.64	1.80	
EVPW1SE2418	233	237	24	18	2.875	11.10	1.02	
EVPW1SE2424	263	271	24	24	2.875	12.82	2.07	
EVPW1SE2430	293	304	24	30	2.875	14.53	2.17	
EVPW1SE2436	344	355	24	36	2.875	16.25	2.27	
EVPW1SE2442	389	405	24	42	2.875	17.96	2.37	
EVPW1SE2448	430	443	24	48	2.875	19.67	2.47	
EVPW1SE2454	465	483	24	54	2.875	21.39	2.25	
EVPW1SE2460	503	520	24	60	2.875	23.10	3.47	

EVPW2SE • Writeboard Extension Module - Two Side

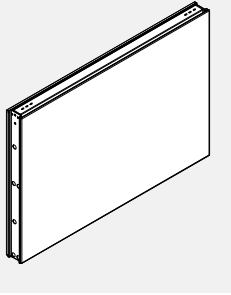

- Single 18" or 24" high module with Writeboard on both sides.
- Use of erasable Writeboard markers only.
- When ordering Panel Extension Module, additional connectors are required.

PRODUCT CODE	PRICE	SIZE/ INCHES			WEIGHT VOL	
		H	W	D	LBS	FT ³
EVPW2SE0618	234	06	18	3	2.77	0.25
EVPW2SE0624	274	06	24	3	3.20	0.35
EVPW2SE0630	318	06	30	3	3.63	0.43
EVPW2SE0636	364	06	36	3	4.06	0.51
EVPW2SE0642	410	06	42	3	4.49	0.60
EVPW2SE0648	460	06	48	3	4.91	0.68
EVPW2SE0654	535	06	54	3	5.34	0.76
EVPW2SE0660	544	06	60	3	5.77	0.84
EVPW2SE0666	555	06	66	3	6.17	0.91
EVPW2SE0672	627	06	72	3	6.57	0.99
EVPW2SE1218	234	12	18	3	5.55	0.51
EVPW2SE1224	274	12	24	3	6.41	0.71
EVPW2SE1230	318	12	30	3	7.26	0.87
EVPW2SE1236	364	12	36	3	8.12	1.03
EVPW2SE1242	410	12	42	3	8.98	1.20
EVPW2SE1248	460	12	48	3	9.83	1.36
EVPW2SE1254	535	12	54	3	10.69	1.53
EVPW2SE1260	544	12	60	3	11.55	1.69
EVPW2SE1266	555	12	66	3	12.41	1.85
EVPW2SE1272	627	12	72	3	13.27	1.99
EVPW2SE1818	279	18	18	2.875	10.29	0.54
EVPW2SE1824	328	18	24	2.875	11.75	0.72
EVPW2SE1830	375	18	30	2.875	13.20	0.90
EVPW2SE1836	446	18	36	2.875	14.66	1.08
EVPW2SE1842	503	18	42	2.875	16.12	1.26
EVPW2SE1848	562	18	48	2.875	17.57	1.44
EVPW2SE1854	622	18	54	2.875	19.03	1.62
EVPW2SE1860	678	18	60	2.875	20.49	1.80
EVPW2SE2418	279	24	18	2.875	12.10	0.75
EVPW2SE2424	328	24	24	2.875	13.82	2.07
EVPW2SE2430	375	24	30	2.875	15.53	2.17
EVPW2SE2436	446	24	36	2.875	17.25	2.27
EVPW2SE2442	503	24	42	2.875	18.96	2.37
EVPW2SE2448	562	24	48	2.875	20.67	2.73
EVPW2SE2454	622	24	54	2.875	22.39	2.35
EVPW2SE2460	678	24	60	2.875	24.10	3.39

EVPGTE • Tempered Glass Panel Extension Module

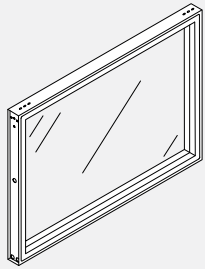

- Single 6", 12", 18" or 24" high module with glazing.
- When ordering Panel Extension Module, additional connectors are required.

PRODUCT CODE	PRICE	SIZE/ INCHES			WEIGHT LBS	VOL FT ³
		H	W	D		
EVPGTE0618	305	6	18	2.875	7.60	0.18
EVPGTE0624	328	6	24	2.875	9.24	0.25
EVPGTE0630	397	6	30	2.875	10.78	0.31
EVPGTE0636	412	6	36	2.875	12.32	0.37
EVPGTE0642	508	6	42	2.875	14.10	0.43
EVPGTE0648	567	6	48	2.875	15.80	0.50
EVPGTE0654	621	6	54	2.875	17.42	0.56
EVPGTE0660	666	6	60	2.875	19.28	0.63
EVPGTE1218	305	12	18	2.875	10.06	0.38
EVPGTE1224	328	12	24	2.875	12.08	0.50
EVPGTE1230	397	12	30	2.875	14.10	0.63
EVPGTE1236	412	12	36	2.875	16.12	0.75
EVPGTE1242	508	12	42	2.875	18.24	0.88
EVPGTE1248	567	12	48	2.875	20.56	1.00
EVPGTE1254	621	12	54	2.875	22.66	1.12
EVPGTE1260	666	12	60	2.875	25.00	1.25
EVPGTE1818	459	18	18	2.875	12.00	0.54
EVPGTE1824	473	18	24	2.875	14.93	0.72
EVPGTE1830	505	18	30	2.875	17.77	0.90
EVPGTE1836	551	18	36	2.875	20.57	1.08
EVPGTE1842	627	18	42	2.875	23.31	1.26
EVPGTE1848	701	18	48	2.875	25.94	1.44
EVPGTE1854	762	18	54	2.875	28.51	1.62
EVPGTE1860	819	18	60	2.875	31.28	1.80
EVPGTE2418	459	24	18	2.875	14.12	0.75
EVPGTE2424	473	24	24	2.875	17.56	1.00
EVPGTE2430	505	24	30	2.875	20.90	1.25
EVPGTE2436	551	24	36	2.875	24.20	1.50
EVPGTE2442	627	24	42	2.875	27.42	1.75
EVPGTE2448	701	24	48	2.875	30.52	2.00
EVPGTE2454	762	24	54	2.875	33.54	2.25
EVPGTE2460	819	24	60	2.875	36.80	2.50

EVPGPTE • Tempered Glass Premium Panel Extension Module

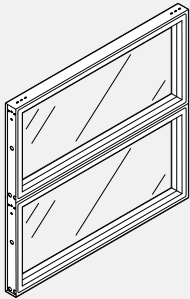

- Two 12" high glazed modules are incorporated into one 24" high metal frame.
- When ordering Panel Extension Module, additional connectors are required.

PRODUCT CODE	PRICE	SIZE/ INCHES			WEIGHT LBS	VOL FT ³
		H	W	D		
EVPGPTE2418	452	24	18	2.875	18.82	1.02
EVPGPTE2424	503	24	24	2.875	22.96	1.42
EVPGPTE2430	573	24	30	2.875	26.99	1.42
EVPGPTE2436	655	24	36	2.875	31.04	1.54
EVPGPTE2442	726	24	42	2.875	35.12	1.72
EVPGPTE2448	816	24	48	2.875	39.99	2.73
EVPGPTE2454	888	24	54	2.875	43.95	3.06
EVPGPTE2460	962	24	60	2.875	48.40	3.39

EVPH1SE • Laminate Extension Module - One Side

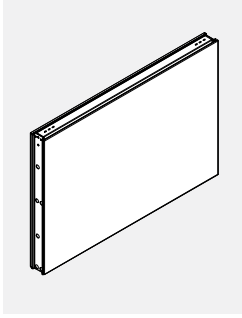

- Laminate face on one side of the module provides durable, washable surfaces. Opposite side is fabric.
- When ordering Panel Extension Module, additional connectors are required.

PRODUCT CODE	PRICE		SIZE/ INCHES			WEIGHT		VOL FT ³
	GR 1	GR 2	H	W	D	LBS		
EVPH1SE0618	212	217	6	18	2.875	2.77	0.25	
EVPH1SE0624	247	259	6	24	2.875	3.20	0.35	
EVPH1SE0630	280	284	6	30	2.875	3.63	0.43	
EVPH1SE0636	319	327	6	36	2.875	4.06	0.51	
EVPH1SE0642	361	367	6	42	2.875	4.49	0.60	
EVPH1SE0648	394	404	6	48	2.875	4.91	0.68	
EVPH1SE0654	446	454	6	54	2.875	5.34	0.76	
EVPH1SE0660	469	477	6	60	2.875	5.77	0.84	
EVPH1SE1218	212	217	12	18	2.875	5.55	0.51	
EVPH1SE1224	247	259	12	24	2.875	6.41	0.71	
EVPH1SE1230	280	284	12	30	2.875	7.26	0.87	
EVPH1SE1236	319	327	12	36	2.875	8.12	1.03	
EVPH1SE1242	361	367	12	42	2.875	8.98	1.20	
EVPH1SE1248	394	404	12	48	2.875	9.83	1.36	
EVPH1SE1254	446	454	12	54	2.875	10.69	1.53	
EVPH1SE1260	469	477	12	60	2.875	11.55	1.69	
EVPH1SE1818	276	281	18	18	2.875	9.44	0.54	
EVPH1SE1824	340	347	18	24	2.875	10.90	0.72	
EVPH1SE1830	391	401	18	30	2.875	12.35	0.90	
EVPH1SE1836	448	457	18	36	2.875	13.81	1.08	
EVPH1SE1842	505	518	18	42	2.875	15.27	1.26	
EVPH1SE1848	553	570	18	48	2.875	16.72	1.44	
EVPH1SE1854	602	619	18	54	2.875	18.18	1.62	
EVPH1SE1860	660	687	18	60	2.875	19.64	1.80	
EVPH1SE2418	286	293	24	18	2.875	11.10	1.02	
EVPH1SE2424	340	349	24	24	2.875	12.82	1.42	
EVPH1SE2430	391	404	24	30	2.875	14.53	1.75	
EVPH1SE2436	448	457	24	36	2.875	16.25	2.07	
EVPH1SE2442	505	517	24	42	2.875	17.96	2.40	
EVPH1SE2448	553	570	24	48	2.875	19.67	2.73	
EVPH1SE2454	602	615	24	54	2.875	21.39	3.06	
EVPH1SE2460	660	682	24	60	2.875	23.10	3.39	

EVPH2SE • Laminate Extension Module - Two Sides

- Laminate face on both sides of the module provides durable, washable surfaces.
- When ordering Panel Extension Module, additional connectors are required.

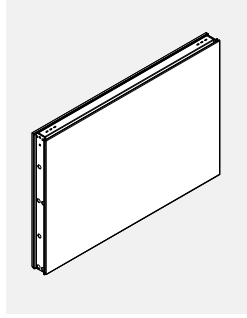

PRODUCT CODE	PRICE	SIZE/ INCHES			WEIGHT LBS	VOL FT ³
		H	W	D		
EVPH2SE0618	234	6	18	2.875	3.03	0.26
EVPH2SE0624	274	6	24	2.875	3.46	0.36
EVPH2SE0630	318	6	30	2.875	3.89	0.44
EVPH2SE0636	364	6	36	2.875	4.32	0.52
EVPH2SE0642	410	6	42	2.875	4.74	0.60
EVPH2SE0648	460	6	48	2.875	5.17	0.69
EVPH2SE0654	535	6	54	2.875	5.60	0.77
EVPH2SE0660	544	6	60	2.875	6.03	0.85
EVPH2SE1218	234	12	18	2.875	6.05	0.51
EVPH2SE1224	274	12	24	2.875	6.91	0.71
EVPH2SE1230	318	12	30	2.875	7.77	0.88
EVPH2SE1236	364	12	36	2.875	8.63	1.04
EVPH2SE1242	410	12	42	2.875	9.48	1.20
EVPH2SE1248	460	12	48	2.875	10.34	1.37
EVPH2SE1254	535	12	54	2.875	11.20	1.53
EVPH2SE1260	544	12	60	2.875	12.05	1.70
EVPH2SE1818	329	18	18	2.875	10.29	0.54
EVPH2SE1824	404	18	24	2.875	11.75	0.72
EVPH2SE1830	469	18	30	2.875	13.20	0.90
EVPH2SE1836	542	18	36	2.875	14.66	1.08
EVPH2SE1842	614	18	42	2.875	16.12	1.26
EVPH2SE1848	694	18	48	2.875	17.57	1.44
EVPH2SE1854	762	18	54	2.875	19.03	1.62
EVPH2SE1860	823	18	60	2.875	20.49	1.80
EVPH2SE2418	329	24	18	2.875	12.10	1.02
EVPH2SE2424	404	24	24	2.875	13.82	1.42
EVPH2SE2430	469	24	30	2.875	15.53	1.75
EVPH2SE2436	542	24	36	2.875	17.25	2.07
EVPH2SE2442	614	24	42	2.875	18.96	2.40
EVPH2SE2448	694	24	48	2.875	20.67	2.73
EVPH2SE2454	762	24	54	2.875	22.39	3.06
EVPH2SE2460	823	24	60	2.875	24.10	3.39

EVPOE • Open Panel Extension Module

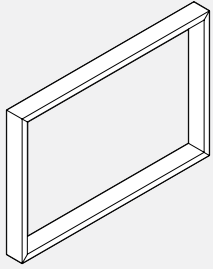

- Provides an opening within a run of panels at a desired location.
- When ordering Panel Extension Module, additional connectors are required.

PRODUCT CODE	PRICE	SIZE/ INCHES			WEIGHT LBS	VOL FT ³
		H	W	D		
EVPOE0618	246	6	18	2.875	6.22	0.26
EVPOE0624	252	6	24	2.875	7.40	0.29
EVPOE0630	307	6	30	2.875	8.48	0.36
EVPOE0636	323	6	36	2.875	9.56	0.43
EVPOE0642	392	6	42	2.875	10.88	0.51
EVPOE0648	442	6	48	2.875	12.12	0.58
EVPOE0654	483	6	54	2.875	13.25	0.65
EVPOE0660	520	6	60	2.875	14.68	0.73
EVPOE1218	246	12	18	2.875	7.30	0.51
EVPOE1224	252	12	24	2.875	8.40	0.59
EVPOE1230	307	12	30	2.875	9.50	0.82
EVPOE1236	323	12	36	2.875	10.60	1.00
EVPOE1242	392	12	42	2.875	11.84	1.00
EVPOE1248	442	12	48	2.875	13.20	1.18
EVPOE1254	483	12	54	2.875	14.38	1.25
EVPOE1260	520	12	60	2.875	15.80	1.32
EVPOE1818	329	18	18	2.875	7.74	0.54
EVPOE1824	369	18	24	2.875	9.18	0.72
EVPOE1830	392	18	30	2.875	10.53	0.90
EVPOE1836	431	18	36	2.875	11.88	1.08
EVPOE1842	485	18	42	2.875	13.09	1.26
EVPOE1848	546	18	48	2.875	14.22	1.44
EVPOE1854	592	18	54	2.875	15.28	1.62
EVPOE1860	638	18	60	2.875	16.56	1.80
EVPOE2418	329	24	18	2.875	8.60	1.02
EVPOE2424	369	24	24	2.875	10.20	1.42
EVPOE2430	392	24	30	2.875	11.70	1.75
EVPOE2436	431	24	36	2.875	13.20	1.95
EVPOE2442	485	24	42	2.875	14.54	2.40
EVPOE2448	546	24	48	2.875	15.80	2.73
EVPOE2454	592	24	54	2.875	16.98	3.06
EVPOE2460	638	24	60	2.875	18.40	3.39

EVPAE • Air Flow Extension Module

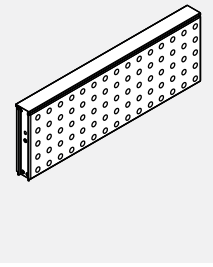

- Metal Air Flow Panel Extension
- Attaches to top of panel
- Panel Extension Modules are not load bearing above 66"
- When ordering Panel Extension Module, additional connectors are required.

PRODUCT CODE	PRICE	SIZE/ INCHES			WEIGHT LBS	VOL FT ³
		H	W	D		
EVPAE1224	270	12	24	2.875	9.66	0.59
EVPAE1230	318	12	30	2.875	10.93	0.82
EVPAE1236	363	12	36	2.875	12.19	1.00
EVPAE1242	401	12	42	2.875	13.62	1.05
EVPAE1248	452	12	48	2.875	15.18	1.18
EVPAE1260	596	12	60	2.875	18.17	1.32
EVPAE1824	339	18	24	2.875	10.56	0.72
EVPAE1830	394	18	30	2.875	12.11	0.90
EVPAE1836	435	18	36	2.875	13.66	1.08
EVPAE1842	478	18	42	2.875	15.05	1.26
EVPAE1848	547	18	48	2.875	16.35	1.44
EVPAE1860	711	18	60	2.875	19.04	1.80
EVPAE2424	339	24	24	2.875	11.73	1.42
EVPAE2430	394	24	30	2.875	13.46	1.75
EVPAE2436	435	24	36	2.875	15.18	1.95
EVPAE2442	478	24	42	2.875	16.72	2.40
EVPAE2448	547	24	48	2.875	18.17	2.73
EVPAE2460	711	24	60	2.875	21.16	3.39

EVPSGE - Pass Thru Sliding Tempered Glass Extension Module

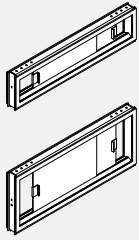

- Pass thru module with sliding tempered glass door.
- Attaches on top of a panel.
- Module can be stacked to add privacy or divide space.
- Panel extension module is not load bearing if installed higher than 66" High.
- When ordering panel extension modules, additional connectors are required.

PRODUCT CODE	PRICE		SIZE/ INCHES			WEIGHT LBS	VOL FT ³
	CLR		H	W	D		
EVPSGE0636	297		6	36	2.875	12.32	0.37
EVPSGE0642	316		6	42	2.875	14.1	0.43
EVPSGE0648	384		6	48	2.875	15.8	0.5
EVPSGE1236	357		12	36	2.875	16.12	0.75
EVPSGE1242	378		12	42	2.875	18.24	0.88
EVPSGE1248	398		12	48	2.875	20.56	1

EVPSGXE - Talk Thru Tempered Glass Extension Module

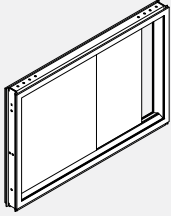

- Talk thru tempered glass module.
- Attaches on top of a panel.
- Module can be stacked to add privacy or divide space.
- Panel extension module is not load bearing if installed higher than 66" High.
- When ordering panel extension modules , additional connectors are required.

PRODUCT CODE	PRICE		SIZE/ INCHES			WEIGHT LBS	VOL FT ³
	CLR		H	W	D		
EVPSGXE2436	460		24	36	2.875	24.2	1.25
EVPSGXE2442	509		24	42	2.875	27.42	1.75
EVPSGXE2448	553		24	48	2.875	30.52	2
EVPSGXE3036	503		30	36	2.875	28.1	1.87
EVPSGXE3042	567		30	42	2.875	31.56	2.2
EVPSGXE3048	613		30	48	2.875	35.28	2.5

EVPFEB • Fabric Panel Bridge Module

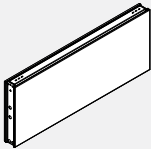

- Bridge modules connects two panels above an opening.
- Requires bridge extension connectors and connects with clamps on top and at bottom.
- Aluminum trim for bottom to be ordered separately.

PRODUCT CODE	PRICE		SIZE/INCHES			WEIGHT LBS	VOL FT ³
	GR1	GR2	H	W	D		
EVPFEB0618	153	160	6	18	2.88	4.80	0.21
EVPFEB0624	159	169	6	24	2.88	6.40	0.29
EVPFEB0630	174	183	6	30	2.88	7.40	0.36
EVPFEB0636	195	207	6	36	2.88	8.20	0.43
EVPFEB0642	217	233	6	42	2.88	9.40	0.51
EVPFEB0648	235	248	6	48	2.88	10.20	0.58
EVPFEB0654	253	271	6	54	2.88	14.40	0.65
EVPFEB0660	276	295	6	60	2.88	16.00	0.73
EVPFEB1218	153	160	12	18	2.88	7.40	0.38
EVPFEB1224	159	168	12	24	2.88	8.60	0.50
EVPFEB1230	174	183	12	30	2.88	9.60	0.63
EVPFEB1236	195	207	12	36	2.88	12.80	0.75
EVPFEB1242	217	231	12	42	2.88	14.80	0.88
EVPFEB1248	235	248	12	48	2.88	15.00	1.00
EVPFEB1254	253	271	12	54	2.88	16.20	1.12
EVPFEB1260	276	295	12	60	2.88	17.80	1.25
EVPFEB1818	190	201	18	18	2.88	9.01	0.54
EVPFEB1824	197	211	18	24	2.88	10.47	0.72
EVPFEB1830	212	234	18	30	2.88	11.93	0.90
EVPFEB1836	246	268	18	36	2.88	13.39	1.08
EVPFEB1842	274	301	18	42	2.88	14.84	1.26
EVPFEB1848	298	328	18	48	2.88	16.29	1.44
EVPFEB1854	324	355	18	54	2.88	17.76	1.62
EVPFEB1860	352	382	18	60	2.88	19.21	1.80
EVPFEB2418	190	201	24	18	2.88	10.60	0.75
EVPFEB2424	197	212	24	24	2.88	12.32	1.00
EVPFEB2430	212	234	24	30	2.88	14.03	1.25
EVPFEB2436	246	268	24	36	2.88	15.75	1.50
EVPFEB2442	274	301	24	42	2.88	17.46	1.75
EVPFEB2448	298	328	24	48	2.88	19.17	2.00
EVPFEB2454	324	355	24	54	2.88	20.89	2.25
EVPFEB2460	352	391	24	60	2.88	22.60	2.50

EVPGTEB • Tempered Glass Bridge Module

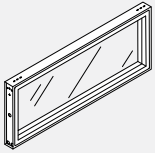

- Bridge modules connects two panels above an opening.
- Requires bridge extension connectors and connects with clamps at bottom.
- Standard in clear (CLR).
- Frosted glass available with a 40% upcharge.
- When ordering bridge modules, additional bridge connectors are required.
- Aluminum trim for bottom to be ordered separately.

PRODUCT CODE	PRICE	SIZE/INCHES			WEIGHT LBS	VOL FT ³
		H	W	D		
EVPGTEB0618	263	6	18	3	7.60	0.18
EVPGTEB0624	281	6	24	3	9.24	0.25
EVPGTEB0630	342	6	30	3	10.78	0.31
EVPGTEB0636	355	6	36	3	12.32	0.37
EVPGTEB0642	437	6	42	3	14.10	0.43
EVPGTEB0648	488	6	48	3	15.80	0.50
EVPGTEB0654	535	6	54	3	17.42	0.56
EVPGTEB0660	574	6	60	3	19.28	0.63
EVPGTEB1218	263	12	18	3	10.06	0.38
EVPGTEB1224	281	12	24	3	12.08	0.50
EVPGTEB1230	342	12	30	3	14.10	0.63
EVPGTEB1236	355	12	36	3	16.12	0.75
EVPGTEB1242	437	12	42	3	18.24	0.88
EVPGTEB1248	488	12	48	3	20.56	1.00
EVPGTEB1254	535	12	54	3	22.66	1.12
EVPGTEB1260	574	12	60	3	25.00	1.25
EVPGTEB1818	396	18	18	3	12.00	0.54
EVPGTEB1824	407	18	24	3	14.93	0.72
EVPGTEB1830	435	18	30	3	17.77	0.90
EVPGTEB1836	475	18	36	3	20.57	1.08
EVPGTEB1842	541	18	42	3	23.31	1.26
EVPGTEB1848	605	18	48	3	25.94	1.44
EVPGTEB1854	657	18	54	3	28.51	1.62
EVPGTEB1860	706	18	60	3	31.28	1.80
EVPGTEB2418	396	24	18	3	14.12	0.75
EVPGTEB2424	407	24	24	3	17.56	1.00
EVPGTEB2430	435	24	30	3	20.90	1.25
EVPGTEB2436	475	24	36	3	24.20	1.50
EVPGTEB2442	541	24	42	3	27.42	1.75
EVPGTEB2448	605	24	48	3	30.52	2.00
EVPGTEB2454	657	24	54	3	33.54	2.25
EVPGTEB2460	706	24	60	3	36.80	2.50

EVPH1SEB • Laminate Bridge Module - Single Sided

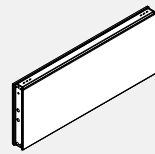

- Bridge modules connects two panels above an opening.
- Requires bridge extension connectors and connects with clamps at bottom.
- Laminate face on one side of module provides durable, washable surface.
- Panel extension module is not load bearing if installed higher than 66" high.
- When ordering bridge modules, additional bridge connectors are required.
- Aluminum trim for bottom to be ordered separately.

PRODUCT CODE	PRICE		SIZE/INCHES			WEIGHT LBS	VOL FT ³
	GR1	GR2	H	W	D		
EVPH1SEB0618	182	187	6	18	3	2.77	0.25
EVPH1SEB0624	213	221	6	24	3	3.20	0.35
EVPH1SEB0630	242	245	6	30	3	3.63	0.43
EVPH1SEB0636	276	280	6	36	3	4.06	0.51
EVPH1SEB0642	310	316	6	42	3	4.49	0.60
EVPH1SEB0648	339	346	6	48	3	4.91	0.68
EVPH1SEB0654	384	391	6	54	3	5.34	0.76
EVPH1SEB0660	403	411	6	60	3	5.77	0.84
EVPH1SEB1218	182	187	12	18	3	5.55	0.51
EVPH1SEB1224	213	221	12	24	3	6.41	0.71
EVPH1SEB1230	242	245	12	30	3	7.26	0.87
EVPH1SEB1236	276	280	12	36	3	8.12	1.03
EVPH1SEB1242	310	316	12	42	3	8.98	1.20
EVPH1SEB1248	339	346	12	48	3	9.83	1.36
EVPH1SEB1254	384	391	12	54	3	10.69	1.53
EVPH1SEB1260	403	411	12	60	3	11.55	1.69
EVPH1SEB1818	238	243	18	18	3	9.44	0.54
EVPH1SEB1824	293	300	18	24	3	10.90	0.72
EVPH1SEB1830	337	345	18	30	3	12.35	0.90
EVPH1SEB1836	385	394	18	36	3	13.81	1.08
EVPH1SEB1842	435	447	18	42	3	15.27	1.26
EVPH1SEB1848	477	491	18	48	3	16.72	1.44
EVPH1SEB1854	517	534	18	54	3	18.18	1.62
EVPH1SEB1860	571	591	18	60	3	19.64	1.80
EVPH1SEB2418	238	243	24	18	3	11.10	1.02
EVPH1SEB2424	293	300	24	24	3	12.82	1.42
EVPH1SEB2430	337	345	24	30	3	14.53	1.75
EVPH1SEB2436	385	394	24	36	3	16.25	2.07
EVPH1SEB2442	435	447	24	42	3	17.96	2.40
EVPH1SEB2448	477	491	24	48	3	19.67	2.73
EVPH1SEB2454	517	534	24	54	3	21.39	3.06
EVPH1SEB2460	571	591	24	60	3	23.10	3.39

EVPH2SEB • Laminate Bridge Module - Double Sided

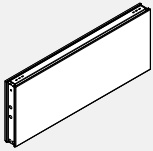

- Bridge modules connects two panels above an opening.
- Requires bridge extension connectors and connects with clamps at bottom.
- Laminate face on two sides of module provides durable, washable surface.
- Panel extension module is not load bearing if installed higher than 66" high.
- When ordering panel extension modules, additional connectors are required.
- Aluminum trim for bottom to be ordered separately.

PRODUCT CODE	PRICE	SIZE/INCHES			WEIGHT LBS	VOL FT³
		H	W	D		
EVPH2SEB0618	200	6	18	3	3.03	0.26
EVPH2SEB0624	236	6	24	3	3.46	0.36
EVPH2SEB0630	275	6	30	3	3.89	0.44
EVPH2SEB0636	312	6	36	3	4.32	0.52
EVPH2SEB0642	353	6	42	3	4.74	0.60
EVPH2SEB0648	398	6	48	3	5.17	0.69
EVPH2SEB0654	459	6	54	3	5.60	0.77
EVPH2SEB0660	469	6	60	3	6.03	0.85
EVPH2SEB1218	200	12	18	3	6.05	0.51
EVPH2SEB1224	236	12	24	3	6.91	0.71
EVPH2SEB1230	275	12	30	3	7.77	0.88
EVPH2SEB1236	312	12	36	3	8.63	1.04
EVPH2SEB1242	353	12	42	3	9.48	1.20
EVPH2SEB1248	398	12	48	3	10.34	1.37
EVPH2SEB1254	459	12	54	3	11.20	1.53
EVPH2SEB1260	469	12	60	3	12.05	1.70
EVPH2SEB1818	283	18	18	3	10.29	0.54
EVPH2SEB1824	346	18	24	3	11.75	0.72
EVPH2SEB1830	403	18	30	3	13.20	0.90
EVPH2SEB1836	467	18	36	3	14.66	1.08
EVPH2SEB1842	529	18	42	3	16.12	1.26
EVPH2SEB1848	598	18	48	3	17.57	1.44
EVPH2SEB1854	657	18	54	3	19.03	1.62
EVPH2SEB1860	709	18	60	3	20.49	1.80
EVPH2SEB2418	283	24	18	3	12.10	1.02
EVPH2SEB2424	346	24	24	3	13.82	1.42
EVPH2SEB2430	403	24	30	3	15.53	1.75
EVPH2SEB2436	467	24	36	3	17.25	2.07
EVPH2SEB2442	529	24	42	3	18.96	2.40
EVPH2SEB2448	598	24	48	3	20.67	2.73
EVPH2SEB2454	657	24	54	3	22.39	3.06
EVPH2SEB2460	709	24	60	3	24.10	3.39

EVPMP-GI-P • Panel Mount Privacy Glass for U Channel, Extended at Both Ends

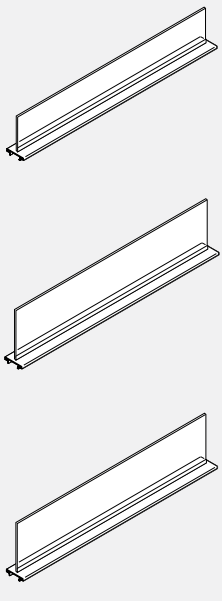

- Privacy Glass integrated with aluminum top trim.
- Attaches on top of panels to add privacy or divide space
- Includes aluminum trim with channel and glass tile.
- Standard in clear (CLR), frosted (FRST) or writeable (WRW) glass.
- Aluminum trim must be specified for entire station when ordering panel mount privacy glass.
- Glass and attachment hardware ship seperately.

PRODUCT CODE	PRICE			SIZE/ INCHES			WEIGHT LBS	VOL FT³
	CLR	FRST	WRW	H	W	D		
EVPMP24GI6P	201	251	-	6	24	2.875	2.39	0.25
EVPMP30GI6P	219	276	-	6	30	2.875	2.99	0.32
EVPMP36GI6P	235	291	-	6	36	2.875	3.58	0.37
EVPMP42GI6P	251	313	-	6	42	2.875	4.18	0.43
EVPMP48GI6P	262	327	-	6	48	2.875	4.78	0.50
EVPMP54GI6P	270	338	-	6	54	2.875	5.38	0.56
EVPMP60GI6P	276	343	-	6	60	2.875	5.97	0.63
EVPMP66GI6P	422	562	-	6	66	2.875	6.57	0.69
EVPMP72GI6P	450	587	-	6	72	2.875	7.16	0.76
EVPMP24GI9P	201	251	-	9	24	2.875	3.58	0.38
EVPMP30GI9P	219	276	-	9	30	2.875	4.48	0.47
EVPMP36GI9P	235	291	-	9	36	2.875	5.37	0.56
EVPMP42GI9P	251	313	-	9	42	2.875	6.26	0.65
EVPMP48GI9P	262	327	-	9	48	2.875	7.16	0.75
EVPMP54GI9P	270	338	-	9	54	2.875	8.06	0.84
EVPMP60GI9P	276	343	-	9	60	2.875	8.96	0.94
EVPMP66GI9P	422	562	-	9	66	2.875	9.85	1.04
EVPMP72GI9P	450	587	-	9	72	2.875	10.74	1.13
EVPMP24GIP	201	251	350	12	24	2.875	4.77	0.50
EVPMP30GIP	219	276	357	12	30	2.875	5.97	0.63
EVPMP36GIP	235	291	364	12	36	2.875	7.16	0.75
EVPMP42GIP	251	313	401	12	42	2.875	8.35	0.87
EVPMP48GIP	262	327	439	12	48	2.875	9.55	1.00
EVPMP54GIP	270	338	475	12	54	2.875	10.75	1.12
EVPMP60GIP	276	343	512	12	60	2.875	11.95	1.25
EVPMP66GIP	422	562	701	12	66	2.875	13.05	1.37
EVPMP72GIP	450	587	734	12	72	2.875	14.25	1.51

EVPMPN-GIP • 12" Integrated Panel Mounted Privacy Glass, 1 Notch

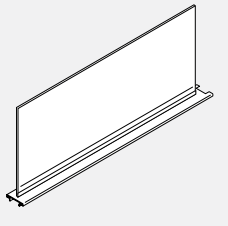

- Privacy Glass Integrated with aluminum top trim.
- Attaches on top of panels to add privacy or divide space.
- Includes aluminum top trim with channel with notched end and glass tile.
- Standard in clear (CLR) or frosted (FRST) glass
- Aluminum trim must be specified for entire station when ordering panel mount privacy glass.
- Glass and attachment hardware to ship separately.

PRODUCT CODE	PRICE		SIZE/ INCHES			WEIGHT LBS	VOL FT ³
	CLR	FRST	H	W	D		
EVPMPN24GIP	201	251	12	24	2.875	4.77	0.50
EVPMPN30GIP	219	276	12	30	2.875	5.97	0.63
EVPMPN36GIP	235	291	12	36	2.875	7.16	0.75
EVPMPN42GIP	251	313	12	42	2.875	8.35	0.87
EVPMPN48GIP	262	327	12	48	2.875	9.55	1.00
EVPMPN54GIP	270	338	12	54	2.875	10.75	1.12
EVPMPN60GIP	276	343	12	60	2.875	11.95	1.25

EVPMPDN-GIP • 12" Integrated Panel Mounted Privacy Glass, 2 Notches

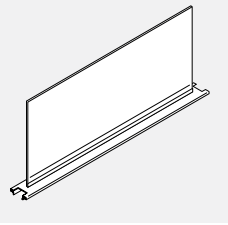

- Privacy Glass Integrated with aluminum top trim.
- Attaches on top of panels to add privacy or divide space.
- Includes aluminum top trim with channel with notched ends and glass tile.
- Standard in clear (CLR) or frosted (FRST) glass
- Aluminum trim must be specified for entire station when ordering panel mount privacy glass.
- Glass and attachment hardware to ship separately.

PRODUCT CODE	PRICE		SIZE/ INCHES			WEIGHT LBS	VOL FT ³
	CLR	FRST	H	W	D		
EVPMPDN24GIP	201	251	12	24	2.875	4.77	0.50
EVPMPDN30GIP	219	276	12	30	2.875	5.97	0.63
EVPMPDN36GIP	235	291	12	36	2.875	7.16	0.75
EVPMPDN42GIP	251	313	12	42	2.875	8.35	0.87
EVPMPDN48GIP	262	327	12	48	2.875	9.55	1.00
EVPMPDN54GIP	270	338	12	54	2.875	10.75	1.12
EVPMPDN60GIP	276	343	12	60	2.875	11.95	1.25

EVPMP-GI-PDU • Panel Mount Privacy Glass for U Channel, Extended at Both Ends

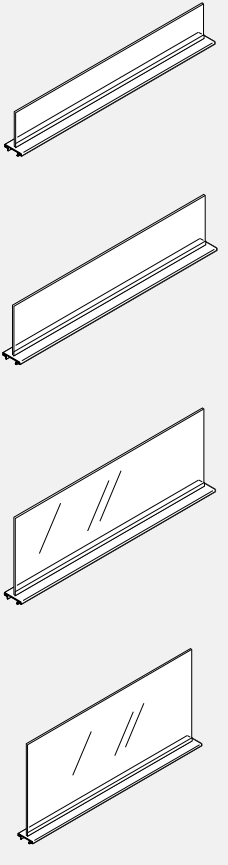

- Privacy glass integrated within aluminum top trim to be used with U channel, with connector for Gallery Panels.
- Attaches on top of panels to add privacy or divide space
- Includes aluminum trim with channel and glass tile
- Standard in clear (CLR) or frosted (FRST) glass
- Aluminum trim must be specified for entire station when ordering panel mount privacy glass.
- Glass and attachment hardware to ship separately
- Trim and glass extended for U channel from both ends.

PRODUCT CODE	PRICE		SIZE/ INCHES			WEIGHT LBS	VOL FT ³
	CLR	FRST	H	W	D		
EVPMP24GI6PDU	212	264	6	25.25	2.39	0.25	
EVPMP30GI6PDU	225	281	6	31.25	2.99	0.32	
EVPMP36GI6PDU	241	303	6	37.25	3.58	0.37	
EVPMP42GI6PDU	249	313	6	43.25	4.18	0.43	
EVPMP48GI6PDU	260	324	6	49.25	4.78	0.50	
EVPMP54GI6PDU	264	331	6	55.25	5.38	0.56	
EVPMP60GI6PDU	408	540	6	61.25	5.97	0.63	
EVPMP66GI6PDU	433	564	6	67.25	6.57	0.69	
EVPMP72GI6PDU	457	589	6	73.25	7.16	0.76	
EVPMP24GI9PDU	212	264	9	25.25	3.58	0.38	
EVPMP30GI9PDU	225	281	9	31.25	4.48	0.47	
EVPMP36GI9PDU	241	303	9	37.25	5.37	0.56	
EVPMP42GI9PDU	249	313	9	43.25	6.26	0.65	
EVPMP48GI9PDU	260	324	9	49.25	7.16	0.75	
EVPMP54GI9PDU	264	331	9	55.25	8.06	0.84	
EVPMP60GI9PDU	408	540	9	61.25	8.96	0.94	
EVPMP66GI9PDU	433	564	9	67.25	9.85	1.04	
EVPMP72GI9PDU	457	589	9	73.25	10.74	1.13	
EVPMP24GIPDU	212	264	12	25.25	4.77	0.50	
EVPMP30GIPDU	225	281	12	31.25	5.97	0.63	
EVPMP36GIPDU	241	303	12	37.25	7.16	0.75	
EVPMP42GIPDU	249	313	12	43.25	8.35	0.87	
EVPMP48GIPDU	260	324	12	49.25	9.55	1.00	
EVPMP54GIPDU	264	331	12	55.25	10.75	1.12	
EVPMP60GIPDU	408	540	12	61.25	11.94	1.25	
EVPMP66GIPDU	433	564	12	67.25	13.13	1.38	
EVPMP72GIPDU	457	589	12	73.25	14.32	1.51	
EVPMP24GI18PDU	392	450	18	25.25	7.16	0.75	
EVPMP30GI18PDU	418	457	18	31.25	8.96	0.94	
EVPMP36GI18PDU	435	505	18	37.25	10.74	1.13	
EVPMP42GI18PDU	461	551	18	43.25	12.53	1.31	
EVPMP48GI18PDU	478	596	18	49.25	14.33	1.50	
EVPMP54GI18PDU	494	645	18	55.25	16.13	1.69	
EVPMP60GI18PDU	553	733	18	61.25	17.91	1.88	
EVPMP66GI18PDU	587	766	18	67.25	19.70	2.06	
EVPMP72GI18PDU	621	800	18	73.25	21.48	2.25	

EVPMP-GI-PU • Panel Mount Privacy Glass for U Channel, Extended at One End

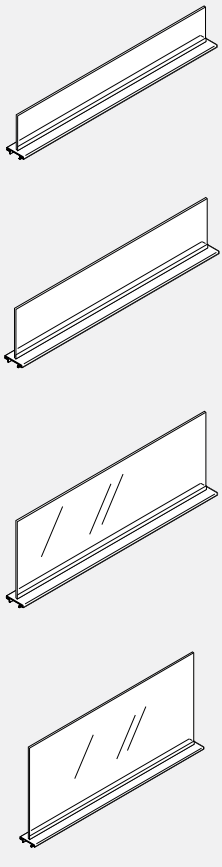

- Privacy glass integrated within aluminum top trim to be used with U channel, with connector for Gallery Panels.
- Attaches on top of panels to add privacy or divide space.
- Includes aluminum trim with channel and glass tile.
- Standard in clear (CLR) or frosted (FRST) glass.
- Aluminium trim must be specified for entire station when ordering panel mount privacy glass.
- Glass and attachment hardware to ship separately.
- Trim and glass extended for U channel on one end.

PRODUCT CODE	PRICE		SIZE/ H	INCHES		WEIGHT VOL	
	CLR	FRST		W	D	LBS	FT³
EVPMP24GI6PU	212	264	6	24.625		2.39	0.25
EVPMP30GI6PU	225	281	6	30.625		2.99	0.32
EVPMP36GI6PU	241	303	6	36.625		3.58	0.37
EVPMP42GI6PU	249	313	6	42.625		4.18	0.43
EVPMP48GI6PU	260	324	6	48.625		4.78	0.50
EVPMP54GI6PU	264	331	6	54.625		5.38	0.56
EVPMP60GI6PU	408	540	6	60.625		5.97	0.63
EVPMP66GI6PU	433	564	6	66.625		6.57	0.69
EVPMP72GI6PU	457	589	6	72.625		7.16	0.76
EVPMP24GI9PU	212	264	9	24.625		3.58	0.38
EVPMP30GI9PU	225	281	9	30.625		4.48	0.47
EVPMP36GI9PU	241	303	9	36.625		5.37	0.56
EVPMP42GI9PU	249	313	9	42.625		6.26	0.65
EVPMP48GI9PU	260	324	9	48.625		7.16	0.75
EVPMP54GI9PU	264	331	9	54.625		8.06	0.84
EVPMP60GI9PU	408	540	9	60.625		8.96	0.94
EVPMP66GI9PU	433	564	9	66.625		9.85	1.04
EVPMP72GI9PU	457	589	9	72.625		10.74	1.13
EVPMP24GI18PU	212	264	12	24.625		4.77	0.50
EVPMP30GI18PU	225	281	12	30.625		5.97	0.63
EVPMP36GI18PU	241	303	12	36.625		7.16	0.75
EVPMP42GI18PU	249	313	12	42.625		8.35	0.87
EVPMP48GI18PU	260	324	12	48.625		9.55	1.00
EVPMP54GI18PU	264	331	12	54.625		10.75	1.12
EVPMP60GI18PU	408	540	12	60.625		11.94	1.25
EVPMP66GI18PU	433	564	12	66.625		13.13	1.38
EVPMP72GI18PU	457	589	12	72.625		14.32	1.51
EVPMP24GI18PU	392	450	18	24.625		7.16	0.75
EVPMP30GI18PU	418	457	18	30.625		8.96	0.94
EVPMP36GI18PU	435	505	18	36.625		10.74	1.13
EVPMP42GI18PU	461	551	18	42.625		12.53	1.31
EVPMP48GI18PU	478	596	18	48.625		14.33	1.50
EVPMP54GI18PU	494	645	18	54.625		16.13	1.69
EVPMP60GI18PU	553	733	18	60.625		17.91	1.88
EVPMP66GI18PU	587	766	18	66.625		19.70	2.06
EVPMP72GI18PU	621	800	18	72.625		21.48	2.25

EVFDK-P • Panel Mount Privacy Felt

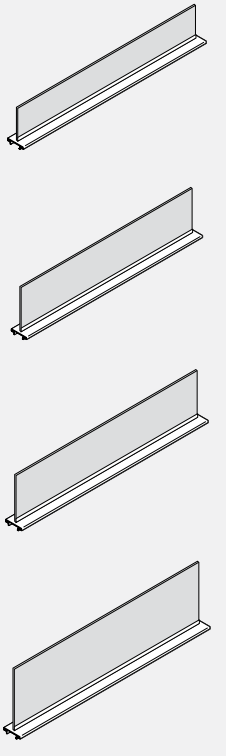

- Privacy felt panel intergrated within aluminum top trim.
- Attaches on top of panels to add privacy or divide space.
- Includes aluminum trim with channel and felt tile.
- Aluminum trim must be specified for entire station when ordering panel mount privacy felt.
- Felt and attachment hardware to ship seperately.
- 9mm Felt material is tackable and comes in 18 different colours. Please specify colour.

PRODUCT CODE	PRICE	SIZE/ INCHES			WEIGHT LBS	VOL FT³
		H	W	D		
EVFDK0624P	72	6	24	2.83	1.42	0.25
EVFDK0630P	88	6	30	2.83	1.73	0.32
EVFDK0636P	102	6	36	2.83	2.03	0.37
EVFDK0642P	113	6	42	2.83	2.34	0.43
EVFDK0648P	170	6	48	2.83	2.64	0.50
EVFDK0654P	183	6	54	2.83	2.95	0.56
EVFDK0660P	199	6	60	2.83	3.25	0.63
EVFDK0666P	210	6	66	2.83	3.56	0.69
EVFDK0672P	238	6	72	2.83	3.86	0.76
EVFDK0924P	72	9	24	2.83	1.63	0.38
EVFDK0930P	88	9	30	2.83	1.99	0.47
EVFDK0936P	102	9	36	2.83	2.35	0.56
EVFDK0942P	113	9	42	2.83	2.70	0.65
EVFDK0948P	170	9	48	2.83	3.06	0.75
EVFDK0954P	183	9	54	2.83	3.42	0.84
EVFDK0960P	199	9	60	2.83	3.78	0.94
EVFDK0966P	210	9	66	2.83	4.13	1.04
EVFDK0972P	238	9	72	2.83	4.49	1.13
EVFDK1224P	72	12	24	2.83	1.84	0.50
EVFDK1230P	88	12	30	2.83	2.25	0.63
EVFDK1236P	102	12	36	2.83	2.66	0.75
EVFDK1242P	113	12	42	2.83	3.07	0.87
EVFDK1248P	170	12	48	2.83	3.48	1.00
EVFDK1254P	183	12	54	2.83	3.89	1.12
EVFDK1260P	199	12	60	2.83	4.30	1.25
EVFDK1266P	210	12	66	2.83	5.12	1.38
EVFDK1272P	238	12	72	2.83	5.53	1.51
EVFDK1824P	92	18	24	2.83	2.26	0.75
EVFDK1830P	108	18	30	2.83	2.77	0.94
EVFDK1836P	128	18	36	2.83	3.29	1.13
EVFDK1842P	143	18	42	2.83	3.80	1.31
EVFDK1848P	212	18	48	2.83	4.32	1.50
EVFDK1854P	231	18	54	2.83	4.83	1.69
EVFDK1860P	248	18	60	2.83	5.35	1.88
EVFDK1866P	262	18	66	2.83	6.68	2.06
EVFDK1872P	298	18	72	2.83	7.20	2.25

EVFDK-PU • Panel Mount Privacy Divider for U Channel

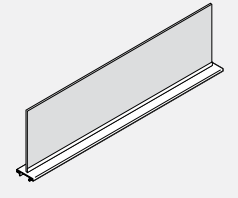

- Attaches on top of panels to add privacy or divide space.
- Privacy felt divider integrated within aluminum top trim to be used with U channel, with connector for Gallery Panels.
- Includes aluminum trim with channel and felt tile.
- Felt and attachment hardware ship separately.
- 9 mm felt material is tackable. Please specify felt finish.
- Aluminum top trim available in standard paint finishes.

PRODUCT CODE	PRICE	SIZE / INCHES			WEIGHT LBS	VOL FT ³
		H	W	D		
EVFDK0618PU	72	6	18.62	2.83	1.42	0.25
EVFDK0624PU	87	6	24.62	2.83	1.73	0.32
EVFDK0630PU	101	6	30.62	2.83	2.03	0.37
EVFDK0636PU	113	6	36.62	2.83	2.34	0.43
EVFDK0642PU	170	6	42.62	2.83	2.64	0.50
EVFDK0648PU	184	6	48.62	2.83	2.95	0.56
EVFDK0654PU	199	6	54.62	2.83	3.25	0.63
EVFDK0660PU	211	6	60.62	2.83	3.56	0.69
EVFDK0666PU	238	6	66.62	2.83	3.86	0.76
EVFDK0672PU	267	6	72.62	2.83	4.16	0.83
EVFDK0918PU	72	9	18.62	2.83	1.63	0.38
EVFDK0924PU	87	9	24.62	2.83	1.99	0.47
EVFDK0930PU	101	9	30.62	2.83	2.35	0.56
EVFDK0936PU	113	9	36.62	2.83	2.70	0.65
EVFDK0942PU	170	9	42.62	2.83	3.06	0.75
EVFDK0948PU	184	9	48.62	2.83	3.42	0.84
EVFDK0954PU	199	9	54.62	2.83	3.78	0.94
EVFDK0960PU	211	9	60.62	2.83	4.13	1.04
EVFDK0966PU	238	9	66.62	2.83	4.49	1.13
EVFDK0972PU	267	9	72.62	2.83	4.85	1.22
EVFDK1218PU	72	12	18.62	2.83	1.84	0.50
EVFDK1224PU	87	12	24.62	2.83	2.25	0.63
EVFDK1230PU	101	12	30.62	2.83	2.66	0.75
EVFDK1236PU	113	12	36.62	2.83	3.07	0.87
EVFDK1242PU	170	12	42.62	2.83	3.48	1.00
EVFDK1248PU	184	12	48.62	2.83	3.89	1.12
EVFDK1254PU	199	12	54.62	2.83	4.30	1.25
EVFDK1260PU	211	12	60.62	2.83	5.12	1.38
EVFDK1266PU	238	12	66.62	2.83	5.53	1.51
EVFDK1272PU	267	12	72.62	2.83	5.94	1.64
EVFDK1818PU	92	18	18.62	2.83	2.83	0.75
EVFDK1824PU	109	18	24.62	2.83	2.77	0.94
EVFDK1830PU	128	18	30.62	2.83	3.29	1.13
EVFDK1836PU	143	18	36.62	2.83	3.80	1.31
EVFDK1842PU	213	18	42.62	2.83	4.32	1.50
EVFDK1848PU	231	18	48.62	2.83	4.83	1.69
EVFDK1854PU	250	18	54.62	2.83	5.35	1.88
EVFDK1860PU	263	18	60.62	2.83	6.68	2.06
EVFDK1866PU	298	18	66.62	2.83	7.20	2.25
EVFDK1872PU	335	18	72.62	2.83	7.72	2.44

EVFDK-PDU • Panel Mount Privacy Divider for U channel , Extended at Both Ends

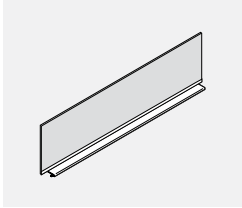

- Attaches on top of panels to add privacy or divide space.
- Privacy felt divider integrated within aluminum top trim to be used with U channel, with connector for Gallery Panels.
- Includes aluminum trim with channel and felt tile.
- Felt and attachment hardware ship separately.
- 9 mm felt material is tackable. Please specify felt finish.
- Aluminum top trim available in standard paint finishes.

PRODUCT CODE	PRICE	SIZE / INCHES			WEIGHT LBS	VOL FT ³
		H	W	D		
EVFDK0618PDU	72	6	19.25	2.83	1.42	0.25
EVFDK0624PDU	87	6	25.25	2.83	1.73	0.32
EVFDK0630PDU	101	6	31.25	2.83	2.03	0.37
EVFDK0636PDU	113	6	37.25	2.83	2.34	0.43
EVFDK0642PDU	170	6	43.25	2.83	2.64	0.50
EVFDK0648PDU	184	6	49.25	2.83	2.95	0.56
EVFDK0654PDU	199	6	55.25	2.83	3.25	0.63
EVFDK0660PDU	211	6	61.25	2.83	3.56	0.69
EVFDK0666PDU	238	6	67.25	2.83	3.86	0.76
EVFDK0672PDU	267	6	73.25	2.83	4.16	0.83
EVFDK0918PDU	72	9	19.25	2.83	1.63	0.38
EVFDK0924PDU	87	9	25.25	2.83	1.99	0.47
EVFDK0930PDU	101	9	31.25	2.83	2.35	0.56
EVFDK0936PDU	113	9	37.25	2.83	2.70	0.65
EVFDK0942PDU	170	9	43.25	2.83	3.06	0.75
EVFDK0948PDU	184	9	49.25	2.83	3.42	0.84
EVFDK0954PDU	199	9	55.25	2.83	3.78	0.94
EVFDK0960PDU	211	9	61.25	2.83	4.13	1.04
EVFDK0966PDU	238	9	67.25	2.83	4.49	1.13
EVFDK0972PDU	267	9	73.25	2.83	4.85	1.22
EVFDK1218PDU	72	12	19.25	2.83	1.84	0.50
EVFDK1224PDU	87	12	25.25	2.83	2.25	0.63
EVFDK1230PDU	101	12	31.25	2.83	2.66	0.75
EVFDK1236PDU	113	12	37.25	2.83	3.07	0.87
EVFDK1242PDU	170	12	43.25	2.83	3.48	1.00
EVFDK1248PDU	184	12	49.25	2.83	3.89	1.12
EVFDK1254PDU	199	12	55.25	2.83	4.30	1.25
EVFDK1260PDU	211	12	61.25	2.83	5.12	1.38
EVFDK1266PDU	238	12	67.25	2.83	5.53	1.51
EVFDK1272PDU	267	12	73.25	2.83	5.94	1.64
EVFDK1818PDU	92	18	19.25	2.83	2.83	0.75
EVFDK1824PDU	109	18	25.25	2.83	2.77	0.94
EVFDK1830PDU	128	18	31.25	2.83	3.29	1.13
EVFDK1836PDU	143	18	37.25	2.83	3.80	1.31
EVFDK1842PDU	213	18	43.25	2.83	4.32	1.50
EVFDK1848PDU	231	18	49.25	2.83	4.83	1.69
EVFDK1854PDU	250	18	55.25	2.83	5.35	1.88
EVFDK1860PDU	263	18	61.25	2.83	6.68	2.06
EVFDK1866PDU	298	18	67.25	2.83	7.20	2.25
EVFDK1872PDU	335	18	73.25	2.83	7.72	2.44

EVFDK12-PN • 12" Panel Mount Privacy Felt 1 Notch

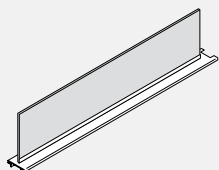

- Privacy felt panel intergrated within aluminum top trim.
- Attaches on top of panels to add privacy or divide space. Includes aluminum trim with channel and felt tile.
- Aluminum trim must be specified for entire station when ordering panel mount privacy felt.
- Felt and attachment hardware to ship seperately.
- 9mm Felt material is tackable. Please specify colour.

PRODUCT CODE	PRICE	SIZE/ INCHES			WEIGHT LBS	VOL FT ³
		H	W	D		
EVFDK1224PN	72	12	24	2.83	1.84	0.50
EVFDK1230PN	88	12	30	2.83	2.25	0.63
EVFDK1236PN	102	12	36	2.83	2.66	0.75
EVFDK1242PN	113	12	42	2.83	3.07	0.87
EVFDK1248PN	170	12	48	2.83	3.48	1.00
EVFDK1254PN	183	12	54	2.83	3.89	1.12
EVFDK1260PN	199	12	60	2.83	4.30	1.25

EVFDK12-PDN • 12" Panel Mount Privacy Felt 2 Notch

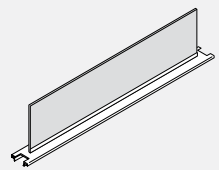

- Privacy felt panel intergrated within aluminum top trim.
- Attaches on top of panels to add privacy or divide space. Includes aluminum trim with channel and felt tile.
- Aluminum trim must be specified for entire station when ordering panel mount privacy felt.
- Felt and attachment hardware to ship seperately.
- 9mm Felt material is tackable. Please specify colour.

PRODUCT CODE	PRICE	SIZE/ INCHES			WEIGHT LBS	VOL FT ³
		H	W	D		
EVFDK1224PDN	72	12	24	2.83	1.84	0.50
EVFDK1230PDN	88	12	30	2.83	2.25	0.63
EVFDK1236PDN	102	12	36	2.83	2.66	0.75
EVFDK1242PDN	113	12	42	2.83	3.07	0.87
EVFDK1248PDN	170	12	48	2.83	3.48	1.00
EVFDK1254PDN	183	12	54	2.83	3.89	1.12
EVFDK1260PDN	199	12	60	2.83	4.30	1.25

EVFPDK06-PCF • 6" H Panel Mount Privacy Divider Ceiling Filler Kit

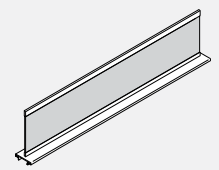

- Privacy Felt Divider integrated within aluminum top trim.
- Includes aluminum trim with channel and Felt tile.
- Felt tile and attachment hardware to ship seperately.
- Please specify felt finish.
- Aluminum top trim available in standard paint finishes.
- PVC cap for closing gap at ceiling included.
- PVC cap available in white only.
- Felt ceiling filler should be used to close the gap between top of panel and ceiling.

PRODUCT CODE	PRICE	SIZE/ INCHES			WEIGHT LBS	VOL FT ³
		H	W	D		
EVFPDK0618PCF	75	6	18	2.83	1.11	0.20
EVFPDK0624PCF	82	6	24	2.83	1.42	0.26
EVFPDK0630PCF	100	6	30	2.83	1.73	0.32
EVFPDK0636PCF	115	6	36	2.83	2.03	0.37
EVFPDK0642PCF	131	6	42	2.83	2.34	0.43
EVFPDK0648PCF	196	6	48	2.83	2.64	0.43
EVFPDK0654PCF	212	6	54	2.83	2.95	0.56
EVFPDK0660PCF	229	6	60	2.83	3.25	0.63
EVFPDK0666PCF	240	6	66	2.83	3.56	0.69
EVFPDK0672PCF	274	6	72	2.83	3.86	0.76

EVFDK06-PCF • 6" H Panel Mount Privacy Divider Ceiling Filler Kit

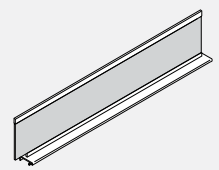

- Privacy Felt Divider integrated with aluminum top trim.
- Includes aluminum trim with channel and Felt tile.
- Felt tile and attachment hardware to ship seperately.
- Please specify felt finish.
- Felt tile is longer and overhangs half of the width of post.
- Aluminum trim is width of panel.
- Aluminum top trim available in standard paint finishes.
- PVC cap for closing gap at ceiling included.
- PVC cap available in white only.
- Felt ceiling filler should be used to close the gap between top of panel and ceiling.

PRODUCT CODE	PRICE	SIZE/ INCHES			WEIGHT LBS	VOL FT ³
		H	W	D		
EVFDK0619PCF	82	6	19.75	2.83	1.42	0.26
EVFDK0625PCF	100	6	25.75	2.83	1.73	0.32
EVFDK0631PCF	115	6	31.75	2.83	2.03	0.37
EVFDK0637PCF	131	6	37.75	2.83	2.34	0.43
EVFDK0643PCF	196	6	43.75	2.83	2.64	0.43
EVFDK0649PCF	212	6	49.75	2.83	2.95	0.56
EVFDK0655PCF	229	6	55.75	2.83	3.25	0.63
EVFDK0661PCF	240	6	61.75	2.83	3.56	0.69
EVFDK0667PCF	274	6	67.75	2.83	3.86	0.76
EVFDK0673PCF	306	6	73.75	2.83	4.16	0.83

POST CONFIGURATIONS • TECHNICAL INFORMATION

As illustrated in the example below, start with position "A" and continue clockwise specifying the height of each slotted connector.

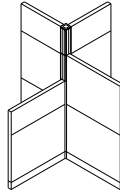
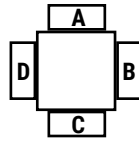
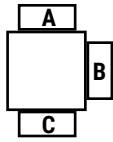
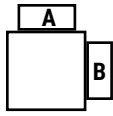

PANEL EXTENSION MODULES

When ordering Panel Extension Modules, Inline Panel Extension Connectors (EVPIEC) must be ordered separately.

Inline Panel Extension Connectors connect two panel extension modules of equal height in a straight run.

Extension connectors do not provide support for hang-on storage above 66".

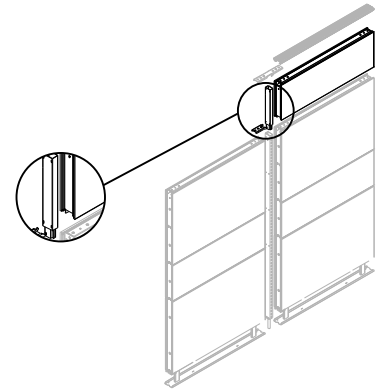
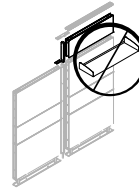

EVPIC • Inline Panel Connector

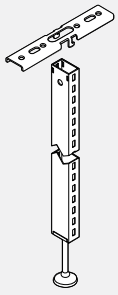

- Connects two panels of equal height in a straight run.
- Provides slotted support for worksurfaces and hang-on storage components.
- Includes slotted connectors with leveling glide and connection hardware.

PRODUCT CODE	PRICE	SIZE/INCHES		WEIGHT VOL	
		H	W	LBS	FT ³
EVPIC30	63	30	2	3.30	0.50
EVPIC42	67	42	2	4.60	0.07
EVPIC48	69	48	2	5.25	0.07
EVPIC54	74	54	2	5.90	0.09
EVPIC66	83	66	2	7.20	0.10

EVPVC • Variable Height Connector

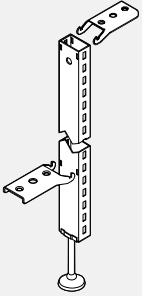

- Connects two panels of different heights in a straight run.
- Connector must reference taller panel.
- Can be used for any variation of panel heights.
- Provides slotted support for worksurfaces and hang-on storage components.
- Includes slotted connector with levelling glide and connection hardware.
- Variable-height trim must be ordered separately, see EVPTV or EVPTVA.

PRODUCT CODE	PRICE	SIZE/INCHES		WEIGHT VOL	
		H	W	LBS	FT ³
EVPVC42	74	42	2	4.60	0.70
EVPVC48	77	48	2	5.25	0.70
EVPVC54	78	54	2	5.90	0.90
EVPVC66	88	66	2	7.20	0.10

EPPERA • End of Run Kit (Wall Mount)

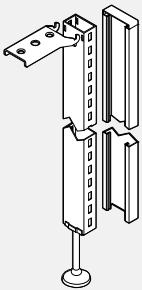

- Finishes the end of each panel run and can be used to attach a panel run to a fixed wall.
- Adds 1" to the width of a panel run.
- Provides slotted support for worksurfaces and hang-on storage components.
- Includes slotted connector with levelling glide, connection hardware and trim kit.
- Can be attached to face of another panel to provide off-modular panel connection by Screwing the trim to the horizontals of the panel.

PRODUCT CODE	PRICE	TYPE	SIZE/INCHES		WEIGHT VOL	
			H	W	LBS	FT ³
EPPERA30	78	Aluminum	30	2.875	3.30	0.07
EPPERA42	94	Aluminum	42	2.875	4.60	0.10
EPPERA48	100	Aluminum	48	2.875	6.75	0.10
EPPERA54	112	Aluminum	54	2.875	5.09	0.18
EPPERA66	126	Aluminum	66	2.875	7.20	0.22

EPPERA • Upmount End of Run Kit

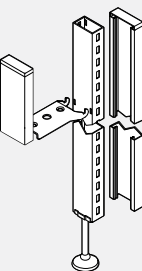

- Replaces the standard End-of-Run Kit EPPERA.
- Used at the end of a panel run to support worksurfaces and Upmount overhead storage.
- Can attach a panel run to a fixed wall.
- Adds 1" to the width of a panel run.
- Includes slotted connector with levelling glide, connection hardware, Upmount End-of-Run Trim EPPERET and one Upmount Extension Trim EPPERET12.

PRODUCT CODE	PRICE	TYPE	SIZE/INCHES		WEIGHT VOL	
			H	W	LBS	FT ³
EPPERERA66	138	Aluminum	66	2.875	7.20	0.22

EPPERA1 • One Way Post

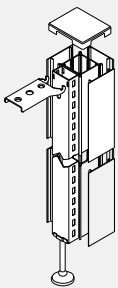

- Replaces an EPPERA End-of-Run Post Kit at the end of a run of panels.
- Used with EPPERPE Post Extension to allow for ceiling entry at end of panel run.
- Adds 2 7/8" to the end of a run of panels.
- Provides slotted support for worksurfaces and hang-on storage components.
- Includes corner post, one slotted connector with levelling glides, attachment hardware and trim.

PRODUCT CODE	PRICE	TYPE	SIZE/INCHES			WEIGHT VOL	
			H	W	D	LBS	FT ³
EPPERCPA130	103	Aluminum	30	2.875		4.97	0.24
EPPERCPA142	117	Aluminum	42	2.875		6.93	0.33
EPPERCPA148	139	Aluminum	48	2.875		7.93	0.38
EPPERCPA154	160	Aluminum	54	2.875		8.93	0.43
EPPERCPA166	199	Aluminum	66	2.875		10.87	0.53

EVPIPA2 • Inline Two Way Post

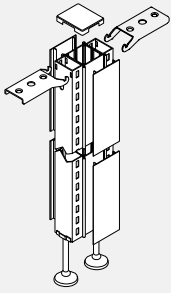

- Connects two panels of equal height in a straight line in place of an EVPIC Inline Panel Connector.
- Adds 2 7/8" to the end of a run of panels.
- Provides slotted support for worksurfaces and hang-on storage components.
- Includes corner post, two slotted connectors with levelling glides, attachment hardware and trim.

PRODUCT CODE	PRICE	TYPE	SIZE/ H	INCHES W	WEIGHT LBS	VOL FT ³
EVPIPA230	162	Aluminum	30	2.875	8.20	0.31
EVPIPA242	207	Aluminum	42	2.875	11.50	0.43
EVPIPA248	217	Aluminum	48	2.875	13.50	0.54
EVPIPA254	251	Aluminum	54	2.875	15.00	0.61
EVPIPA266	299	Aluminum	66	2.875	19.00	0.75

EVPCPA2 • Two Way Corner Post

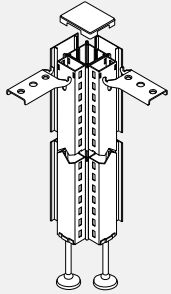

- Attaches two panels of equal height in 90° configuration.
- Provides slotted support for worksurfaces and hang-on storage components.
- Includes corner post, two slotted connectors with levelling glides, attachment hardware and trim.

PRODUCT CODE	PRICE	TYPE	SIZE/ H	INCHES W	WEIGHT LBS	VOL FT ³
EVPCPA230	162	Aluminum	30	2.875	8.50	0.31
EVPCPA242	207	Aluminum	42	2.875	11.50	0.43
EVPCPA248	217	Aluminum	48	2.875	11.50	0.43
EVPCPA254	251	Aluminum	54	2.875	15.00	0.61
EVPCPA266	299	Aluminum	66	2.875	19.00	0.75

EVPCPA3 • Three Way Corner Post

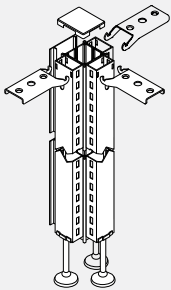

- Attaches three panels of equal height in a "T" configuration.
- Provides slotted support for worksurfaces and hang-on storage components.
- Includes corner post, three slotted connectors with levelling glides, attachment hardware top cap and trim.

PRODUCT CODE	PRICE	TYPE	SIZE/ H	INCHES W	WEIGHT LBS	VOL FT ³
EVPCPA330	195	Aluminum	30	2.875	11.80	0.36
EVPCPA342	260	Aluminum	42	2.875	16.10	0.50
EVPCPA348	286	Aluminum	48	2.875	18.75	0.61
EVPCPA354	317	Aluminum	54	2.875	20.50	0.70
EVPCPA366	373	Aluminum	66	2.875	26.20	0.85

EVPCP4 • Four Way Corner Post

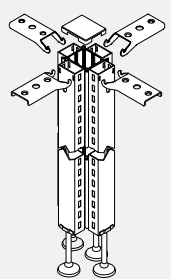

- Attaches four panels of equal height in an "X" configuration.
- Provides slotted support for worksurfaces and hang-on storage components.
- Includes corner post, four slotted connectors with levelling glides, attachment hardware and top cap.

PRODUCT CODE	PRICE	TYPE	SIZE/ H	INCHES W	WEIGHT LBS	VOL FT ³
EVPCP430	213	Aluminum	30	2.875	15.50	0.41
EVPCP442	279	Aluminum	42	2.875	21.00	0.57
EVPCP448	307	Aluminum	48	2.875	24.00	0.68
EVPCP454	339	Aluminum	54	2.875	26.50	0.79
EVPCP466	397	Aluminum	66	2.875	33.20	0.95

EVVPA2 • Two Way Variable Height Corner Post

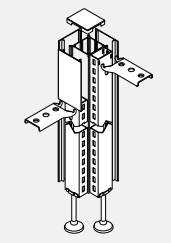

- Attaches two panels of different heights at a corner.
- Specify the corner post height that matches the tallest panel attached to the post face.
- Provides slotted support for worksurfaces and hang-on storage components.
- Includes corner post, two slotted connectors with levelling glides, attachment hardware and trim.
- Configuration of connecting panels must be specified. ie. 54/66. See Technical Information at the beginning of this section.

PRODUCT CODE	PRICE	TYPE	SIZE/ H	INCHES W	WEIGHT LBS	VOL FT ³
EVVPA242	207	Aluminum	42	2.875	10.00	1.30
EVVPA248	229	Aluminum	48	2.875	13.50	1.50
EVVPA254	251	Aluminum	54	2.875	17.00	1.80
EVVPA266	299	Aluminum	66	2.875	20.50	2.10

EVPVPA3 • Three Way Variable Height Corner Post

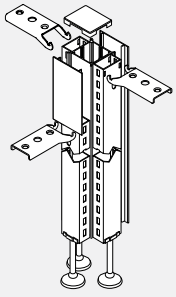

- Attaches three panels of different heights in a "T" configuration.
- Specify the corner post height that matches the tallest panel attached to the post face.
- Provides slotted support for worksurfaces and hang-on storage components.
- Includes corner post, three slotted connectors with levelling glides, attachment hardware and trim.
- Configuration of connecting panels must be specified. ie. 54/42/66. See Technical information page at the beginning of this section.

PRODUCT CODE	PRICE	TYPE	SIZE/ H	INCHES W	WEIGHT LBS	VOL FT ³
EVPVPA342	260	Aluminum	42	2.875	12.50	0.30
EVPVPA348	286	Aluminum	48	2.875	15.50	0.66
EVPVPA354	317	Aluminum	54	2.875	18.50	0.68
EVPVPA366	373	Aluminum	66	2.875	24.20	0.90

EVPVPA4 • Four Way Variable Height Corner Post

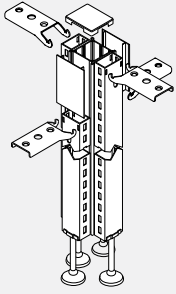

- Attaches four panels of different heights in an "X" configuration.
- Specify the corner post height that matches the tallest panel attached to the post face.
- Provides slotted support for worksurfaces and hang-on storage components.
- Includes corner post, four slotted connectors with levelling glides, attachment hardware and trim.
- Configuration of connecting panels must be specified. ie. 42/66/54/42. See Technical information page at the beginning of this section.

PRODUCT CODE	PRICE	TYPE	SIZE/ H	INCHES W	WEIGHT LBS	VOL FT ³
EVPVPA442	293	Aluminum	42	2.875	18.50	0.35
EVPVPA448	323	Aluminum	48	2.875	20.50	0.70
EVPVPA454	353	Aluminum	54	2.875	24.50	1.05
EVPVPA466	417	Aluminum	66	2.875	30.20	1.40

EVPIEC • Inline Panel Extension Connector - Non Slotted

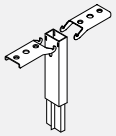

- Connects two panel extension modules of equal height in a straight run.
- Does not provide support for hang-on storage components.

PRODUCT CODE	PRICE	SIZE/ H	INCHES W	WEIGHT LBS	VOL FT ³
EVPIEC06	30	6	2	1.00	0.06
EVPIEC12	30	12	2	2.00	0.12
EVPIEC18	36	18	2	3.00	0.18
EVPIEC24	36	24	2	4.00	0.24

EVPIECS • Inline Panel Extension Connector - Slotted

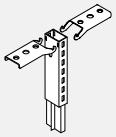

- Connects two panel extension modules of equal height in a straight run.
- Provides slotted support up to 66" high for worksurfaces and hang-on storage components.

PRODUCT CODE	PRICE	SIZE/ H	INCHES W	WEIGHT LBS	VOL FT ³
EVPIECS06	37	6	2	1.00	0.06
EVPIECS12	37	12	2	2.00	0.12
EVPIECS18	43	18	2	3.00	0.18
EVPIECS24	43	24	2	4.00	0.24

EVPEERA • End of Run Extension - Non Slotted

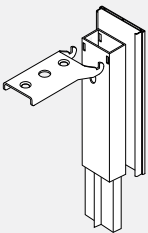

- Extends an End-of-Run Kit.
- Does not provide support for hang-on storage components.
- Includes Inline Panel Extension Connector (EVPIEC) and Panel Extension Trim (EVPTEA).

PRODUCT CODE	PRICE	TYPE	SIZE/ H	INCHES W	WEIGHT LBS	VOL FT ³
EVPEERA06	34	Aluminum	6	2.875	1.00	0.06
EVPEERA12	34	Aluminum	12	2.875	2.00	0.12
EVPEERA18	40	Aluminum	18	2.875	3.00	0.18
EVPEERA24	40	Aluminum	24	2.875	4.00	0.24

EVPEERSA • End of Run Extension - Slotted

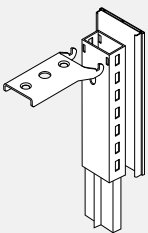

- Extends an End-of-Run Kit.
- Provides slotted support up to 66" high for worksurfaces and hang-on storage components.
- Includes Inline Panel Extension Connector (EVPIECS) and Panel Extension Trim (EVPTE or EVPTEA).

PRODUCT CODE	PRICE	TYPE	SIZE/ H	INCHES W	WEIGHT LBS	VOL FT ³
EVPEERSA06	40	Aluminum	6	2.875	1.00	0.06
EVPEERSA12	40	Aluminum	12	2.875	2.00	0.12
EVPEERSA18	61	Aluminum	18	2.875	3.00	0.18
EVPEERSA24	61	Aluminum	24	2.875	4.00	0.24

EVPCEPA1 • One Way Post Extension - Non Slotted

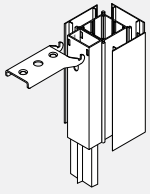

- Attaches to a corner post at the end of a run of panel extension modules.
- Includes corner extension post, one non-slotted connector, attachment hardware and trim.

PRODUCT CODE	PRICE	TYPE	SIZE/ H	INCHES W	WEIGHT LBS	VOL FT ³
EVPCEPA106	66	Aluminum	6	2.875	2.00	0.07
EVPCEPA112	66	Aluminum	12	2.875	4.00	0.14
EVPCEPA118	91	Aluminum	18	2.875	6.00	0.21
EVPCEPA124	91	Aluminum	24	2.875	8.00	0.28

EVPCEPSA1 • One Way Post Extension - Slotted

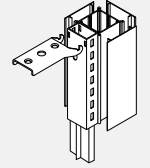

- Attaches to a corner post at the end of a run of panel extension modules.
- Provides slotted support up to 66" high for worksurfaces and hang-on storage components.
- Includes corner extension post, one slotted connector, attachment hardware and trim.

PRODUCT CODE	PRICE	TYPE	SIZE/ H	INCHES W	WEIGHT LBS	VOL FT ³
EVPCEPSA106	89	Aluminum	6	2.875	2.00	0.07
EVPCEPSA112	89	Aluminum	12	2.875	4.00	0.14
EVPCEPSA118	112	Aluminum	18	2.875	6.00	0.21
EVPCEPSA124	112	Aluminum	24	2.875	8.00	0.28

EVPCEIPA2 • Inline Post Extension - Non Slotted

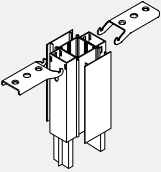

- Attaches to a corner post and connects two panel extension modules in a straight line.
- Includes corner extension post, two non-slotted connectors, attachment hardware and trim.

PRODUCT CODE	PRICE	TYPE	SIZE/ H	INCHES W	WEIGHT LBS	VOL FT ³
EVPCEIPA206	90	Aluminum	6	2.875	2.00	0.07
EVPCEIPA212	90	Aluminum	12	2.875	4.00	0.14
EVPCEIPA218	140	Aluminum	18	2.875	6.00	0.18
EVPCEIPA224	140	Aluminum	24	2.875	8.00	0.28

EVPCEIPSA2 • Inline Post Extension - Slotted

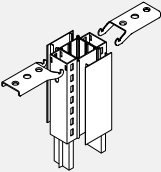

- Attaches to a corner post and connects two panel extension modules in a straight line.
- Provides slotted support up to 66" high for worksurfaces and hang-on storage components.
- Includes corner extension post, two slotted connectors, attachment hardware and trim.

PRODUCT CODE	PRICE	TYPE	SIZE/ H	INCHES W	WEIGHT LBS	VOL FT ³
EVPCEIPSA206	90	Aluminum	6	2.875	2.00	0.07
EVPCEIPSA212	90	Aluminum	12	2.875	4.00	0.14
EVPCEIPSA218	140	Aluminum	18	2.875	6.00	0.18
EVPCEIPSA224	140	Aluminum	24	2.875	8.00	0.28

EVPCEPA2 • Two Way Post Extension - Non Slotted

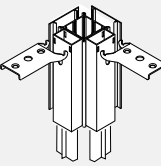

- Connects two panel extension modules of equal height in a corner "L" configuration.
- Includes corner extension post, two non-slotted connectors, attachment hardware and trim.

PRODUCT CODE	PRICE	TYPE	SIZE/ H	INCHES W	WEIGHT LBS	VOL FT ³
EVPCEPA206	72	Aluminum	6	2.875	2.00	0.07
EVPCEPA212	72	Aluminum	12	2.875	4.00	0.14
EVPCEPA218	122	Aluminum	18	2.875	6.00	0.21
EVPCEPA224	122	Aluminum	24	2.875	8.00	0.28

EVPCEPSA2 • Two Way Post Extension - Slotted

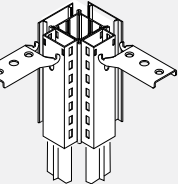

- Connects two panel extension modules of equal height in a 90° configuration.
- Includes corner extension post, two slotted connectors, attachment hardware and trim.

PRODUCT CODE	PRICE	TYPE	SIZE/ H	INCHES W	WEIGHT LBS	VOL FT ³
EVPCEPSA206	90	Aluminum	6	2.875	2.00	0.07
EVPCEPSA212	90	Aluminum	12	2.875	4.00	0.14
EVPCEPSA218	140	Aluminum	18	2.875	6.00	0.21
EVPCEPSA224	140	Aluminum	24	2.875	8.00	0.28

EVPCEPA3 • Three Way Post Extension - Non Slotted

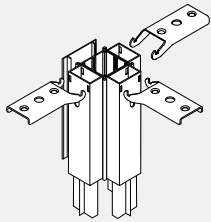

- Connects three panel extension modules of equal height in a corner "T" configuration.
- Includes corner extension post, three non-slotted connectors, attachment hardware and trim.

PRODUCT CODE	PRICE	TYPE	SIZE/ H	INCHES W	WEIGHT LBS	VOL FT ³
EVPCEPA306	80	Aluminum	6	2.875	3.00	0.08
EVPCEPA312	80	Aluminum	12	2.875	6.00	0.16
EVPCEPA318	133	Aluminum	18	2.875	9.00	0.24
EVPCEPA324	133	Aluminum	24	2.875	12.00	0.32

EVPCEPSA3 • Three Way Post Extension - Slotted

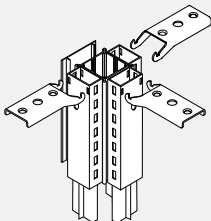

- Connects three panel extension modules of equal height in a corner "T" configuration.
- Includes corner extension post, three slotted connectors, attachment hardware and trim.

PRODUCT CODE	PRICE	TYPE	SIZE/ H	INCHES W	WEIGHT LBS	VOL FT ³
EVPCEPSA306	103	Aluminum	6	2.875	3.00	0.08
EVPCEPSA312	103	Aluminum	12	2.875	6.00	0.16
EVPCEPSA318	161	Aluminum	18	2.875	9.00	0.24
EVPCEPSA324	161	Aluminum	24	2.875	12.00	0.32

EVPCEP4 • Four Way Post Extension - Non Slotted

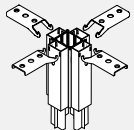

- Connects four panel extension modules of equal height in a corner "X" configuration.
- Includes corner extension post, four non-slotted connectors and attachment hardware.

PRODUCT CODE	PRICE	SIZE/ H	INCHES W	WEIGHT LBS	VOL FT ³
EVPCEP406	74	6	2.875	4.00	0.09
EVPCEP412	74	12	2.875	8.00	0.18
EVPCEP418	117	18	2.875	12.00	0.27
EVPCEP424	117	24	2.875	16.00	0.36

EVPCEPS4 • Four Way Extension Post - Slotted

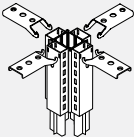

- Connects four panel extension modules of equal height in a corner "X" four-way configuration.
- Includes corner extension post, four slotted connectors and attachment hardware.

PRODUCT CODE	PRICE	SIZE/ H	INCHES W	WEIGHT LBS	VOL FT ³
EVPCEPS406	106	6	2.875	4.00	0.09
EVPCEPS412	106	12	2.875	8.00	0.18
EVPCEPS418	145	18	2.875	12.00	0.27
EVPCEPS424	159	24	2.875	16.00	0.36

EVP4PA • Two Way 45° Corner Post

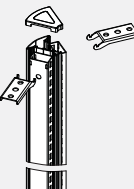

- Attaches two Panels of equal height in a 135° configuration.
- Provides slotted support for worksurfaces and hang-on storage components.
- Includes corner post, two slotted connectors with leveling glides and connecting hardware.
- Connectors available without slots as a special at no upcharge. Contact Customer Support.
- Does not allow to run wires under top trim.

PRODUCT CODE	PRICE	SIZE/ H	INCHES W	WEIGHT LBS	VOL FT ³
EVP4PA230	147	30	3.65	8.50	0.310
EVP4PA242	187	42	3.65	11.50	0.430
EVP4PA248	197	48	3.65	13.50	0.540
EVP4PA254	229	54	3.65	15.00	0.610
EVP4PA266	271	66	3.65	19.00	0.750

EVP4VPA • Variable Height Two Way 45° Corner Post - Aluminum

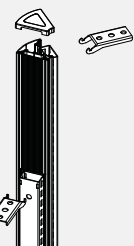

- Attaches two Panels of different height in a 135° configuration.
- Specify the corner post height that matches the tallest panel attached to the post face.
- Provides slotted support for worksurfaces and hang-on storage components.
- Includes corner post, two slotted connectors with leveling glides and connecting hardware.
- Connectors available without slots as a special at no upcharge. Contact Customer Support.
- Do not allow to run wires under the top trim.

PRODUCT CODE	PRICE	SIZE/ H	INCHES W	WEIGHT LBS	VOL FT ³
EVP4VPA242	197	42	3.65	8.50	0.310
EVP4VPA248	218	48	3.65	11.50	0.430
EVP4VPA254	240	54	3.65	13.50	0.540
EVP4VPA266	286	66	3.65	15.00	0.610

EVP4CEPSA • One Way 45° Corner Post Extension - Slotted - Aluminum

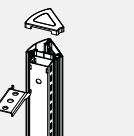

- Attached to a corner post at the end of run of panel extension modules.
- Provides slotted support up to 66" high for worksurfaces and hang-on storage components.
- Includes corner extension post, one slotted connectors, connecting hardware and trim kit.

PRODUCT CODE	PRICE	SIZE/ H	INCHES W	WEIGHT LBS	VOL FT ³
EVP4CEPSA106	80	6	3.65	6	3.65
EVP4CEPSA112	83	12	3.65	12	3.65
EVP4CEPSA118	109	18	3.65	18	3.65
EVP4CEPSA124	109	24	3.65	24	3.65

EVP4CEPA • One Way 45° Corner Post Extension - Non Slotted - Aluminum

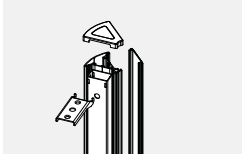

- Attached to a corner post at the end of run of panel extension modules.
- Includes corner extension post, one non-slotted connectors, connecting hardware and trim kit.

PRODUCT CODE	PRICE	SIZE/ H	INCHES W	WEIGHT LBS	VOL FT ³
EVP4CEPA106	61	6	3.65	6	3.65
EVP4CEPA112	65	12	3.65	12	3.65
EVP4CEPA118	88	18	3.65	18	3.65
EVP4CEPA124	88	24	3.65	24	3.65

EVP6PA2 • Two Way 60° Corner Post - Aluminum

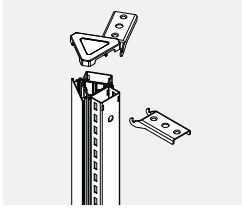

- Attaches two Panels of equal height in a 120° configuration.
- Provides slotted support for worksurfaces and hang-on storage components.
- Includes corner post, two slotted connectors with leveling glides, connecting hardware and trim kit.
- Connectors available without slots as a special at no upcharge. Contact Customer Support.

PRODUCT CODE	PRICE	SIZE/ H	INCHES W	WEIGHT LBS	VOL FT ³
EVP6PA230	157	30	3.65	8.50	0.310
EVP6PA242	195	42	3.65	11.50	0.430
EVP6PA248	212	48	3.65	13.50	0.540
EVP6PA254	241	54	3.65	15.00	0.610
EVP6PA266	286	66	3.65	19.00	0.750

EVP6P3 • Three Way 60° Corner Post

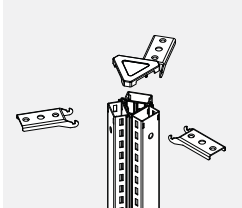

- Attaches three panels of equal height in a 120° configuration.
- Provides slotted support for worksurfaces and hang-on storage components.
- Includes corner post, two slotted connectors with leveling glides and connecting hardware.
- Connectors available without slots as a special at no upcharge. Contact Customer Support.

PRODUCT CODE	PRICE	SIZE/ H	INCHES W	WEIGHT LBS	VOL FT ³
EVP6P330	169	30	3.65	11.90	0.360
EVP6P342	227	42	3.65	16.10	0.500
EVP6P348	249	48	3.65	18.75	0.610
EVP6P354	276	54	3.65	20.50	0.700
EVP6P366	327	66	3.65	26.20	0.850

EVP6VPA2 • Variable Height Two Way 60° Corner Post - Aluminum

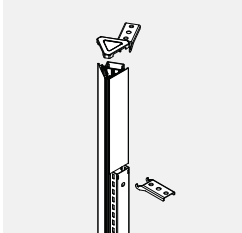

- Attaches two Panels of different height in a 120° configuration.
- Specify the corner post height that matches the tallest panel attached to the post face.
- Provides slotted support for worksurfaces and hang-on storage components.
- Includes corner post, two slotted connectors with leveling glides, connecting hardware and trim kit.
- Connectors available without slots as a special at no upcharge. Contact Customer Support

PRODUCT CODE	PRICE	SIZE/ H	INCHES W	WEIGHT LBS	VOL FT ³
EVP6VPA242	197	30	3.65	12.50	0.490
EVP6VPA248	218	42	3.65	15.40	0.660
EVP6VPA254	240	48	3.65	19.00	0.700
EVP6VPA266	286	54	3.65	22.50	0.750

EVP6VPA3 • Variable Height Three Way 60° Corner Post - Aluminum

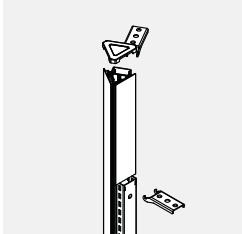

- Attaches two Panels of different height in a 120° configuration.
- Specify the corner post height that matches the tallest panel attached to the post face.
- Provides slotted support for worksurfaces and hang-on storage components.
- Includes corner post, two slotted connectors with leveling glides, connecting hardware and trim kit.
- Connectors available without slots as a special at no upcharge. Contact Customer Support

PRODUCT CODE	PRICE	SIZE/ H	INCHES W	WEIGHT LBS	VOL FT ³
EVP6VPA342	247	30	3.65	18.50	0.550
EVP6VPA348	276	42	3.65	20.50	0.700
EVP6VPA354	313	48	3.65	24.50	1.050
EVP6VPA366	361	54	3.65	30.20	1.400

EVP4CEPS2 • Two Way 45° Corner Post Extension - Slotted

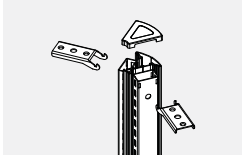

- Used to connect two panel extension modules of equal height.
- Provides slotted support up to 66" high for worksurfaces and hang-on storage components.
- Includes corner extension post, two slotted connectors and connecting hardware.

PRODUCT CODE	PRICE	SIZE/ H	INCHES W	WEIGHT LBS	VOL FT ³
EVP4CEPS206	74	6	3.65	6	3.65
EVP4CEPS212	74	12	3.65	12	3.65
EVP4CEPS218	115	18	3.65	18	3.65
EVP4CEPS224	115	24	3.65	24	3.65

EVP4CEP2 • Two Way 45° Corner Post Extension - Non Slotted

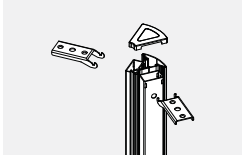

- Used to connect two panel extension modules of equal height.
- Includes corner extension post, two non-slotted connectors and connecting hardware.

PRODUCT CODE	PRICE	SIZE/ H	INCHES W	WEIGHT LBS	VOL FT ³
EVP4CEP206	60	6	3.65	6	3.65
EVP4CEP212	60	12	3.65	12	3.65
EVP4CEP218	108	18	3.65	18	3.65
EVP4CEP224	108	24	3.65	24	3.65

EVP6CEPSA • One Way 60° Corner Post Extension - Slotted - Aluminum

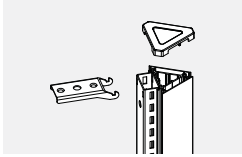

- Attached to a corner post at the end of run of panel extension modules.
- Provides slotted support up to 66" high for worksurfaces and hang-on storage components.
- Includes corner extension post, one slotted connectors, connecting hardware and trim kit.

PRODUCT CODE	PRICE	SIZE/ H	INCHES W	WEIGHT LBS	VOL FT ³
EVP6CEPSA106	80	6	3.65	6	3.65
EVP6CEPSA112	83	12	3.65	12	3.65
EVP6CEPSA118	109	18	3.65	18	3.65
EVP6CEPSA124	109	24	3.65	24	3.65

EVP6CEPA • One Way 60° Corner Post Extension - Non Slotted - Aluminum

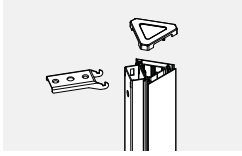

- Attached to a corner post at the end of run of panel extension modules.
- Includes corner extension post, one non-slotted connectors, connecting hardware and trim kit.

PRODUCT CODE	PRICE	SIZE/ H	INCHES W	WEIGHT LBS	VOL FT ³
EVP6CEPA106	61	6	3.65	6	3.65
EVP6CEPA112	65	12	3.65	12	3.65
EVP6CEPA118	88	18	3.65	18	3.65
EVP6CEPA124	88	24	3.65	24	3.65

EVP6CEPSA2 • Two Way 60° Corner Post Extension - Slotted - Aluminum

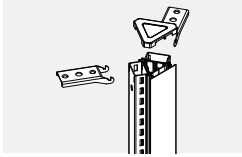

- Used to connect two panel extension modules of equal height.
- Provides slotted support up to 66" high for worksurfaces and hang-on storage components.
- Includes corner extension post, two non-slotted connectors, connecting hardware and trim kit.

PRODUCT CODE	PRICE	SIZE/ H	INCHES W	WEIGHT LBS	VOL FT ³
EVP6CEPSA206	88	6	3.65	6	3.65
EVP6CEPSA212	88	12	3.65	12	3.65
EVP6CEPSA218	136	18	3.65	18	3.65
EVP6CEPSA224	136	24	3.65	24	3.65

EVP6CEPA2 • Two Way 60° Corner Post Extension - Non Slotted - Aluminum

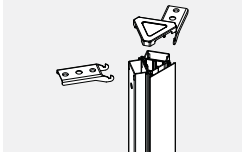

- Used to connect two panel extension modules of equal height.
- Includes corner extension post, two non-slotted connectors, connecting hardware and trim kit.

PRODUCT CODE	PRICE	SIZE/ H	INCHES W	WEIGHT LBS	VOL FT ³
EVP6CEPA206	72	6	3.65	6	3.65
EVP6CEPA212	81	12	3.65	12	3.65
EVP6CEPA218	116	18	3.65	18	3.65
EVP6CEPA224	116	24	3.65	24	3.65

EVP6CEPS3 • Three Way 60° Corner Post Extension - Slotted

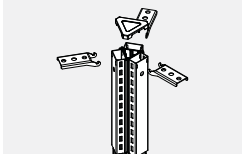

- Used to connect two panel extension modules of equal height.
- Provides slotted support up to 66" high for worksurfaces and hang-on storage components.
- Includes corner extension post, two slotted connectors and connecting hardware

PRODUCT CODE	PRICE	SIZE/ H	INCHES W	WEIGHT LBS	VOL FT ³
EVP6CEPS306	89	6	3.65	6	3.65
EVP6CEPS312	89	12	3.65	12	3.65
EVP6CEPS318	139	18	3.65	18	3.65
EVP6CEPS324	139	24	3.65	24	3.65

EVP6CEP3 • Three Way 60° Corner Post Extension - Non Slotted

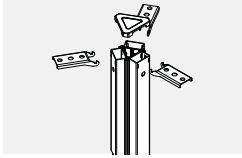

- Used to connect two panel extension modules of equal height.
- Includes corner extension post, two non-slotted connectors and connecting hardware.

PRODUCT CODE	PRICE	SIZE/ H	INCHES W	WEIGHT LBS	VOL FT ³
EVP6CEP306	69	6	3.65	6	3.65
EVP6CEP312	69	12	3.65	12	3.65
EVP6CEP318	112	18	3.65	18	3.65
EVP6CEP324	112	24	3.65	24	3.65

EVPVTFA • Flat Trim - Aluminum

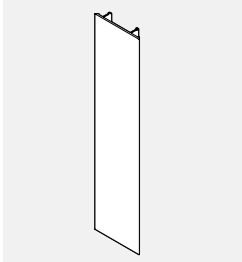

- Finishes exposed faces of one way, two way, three way and inline posts.
- For reconfiguration and replacement use only.

PRODUCT CODE	PRICE	SIZE/ H	INCHES W	WEIGHT LBS	VOL FT ³
EVPVTFA30	16	29.125	2.875	0.39	0.05
EVPVTFA36	16	35.125	2.875	0.44	0.06
EVPVTFA42	23	41.125	2.875	0.56	0.07
EVPVTFA48	24	47.125	2.875	0.62	0.08
EVPVTFA54	25	53.125	2.875	0.75	0.09
EVPVTFA66	27	65.125	2.875	0.86	0.12
EVPVTFA72	29	71.125	2.875	0.92	0.12
EVPVTFA78	30	77.125	2.875	0.97	0.12
EVPVTFA84	31	83.125	2.875	1.09	0.14
EVPVTFA90	31	89.125	2.875	1.14	0.15
EVPVTFA96	33	95.125	2.875	1.19	0.21

EVPVTFEA • Flat Variable Height Extension Trim - Aluminum



- Finishes exposed faces of one way, two way, three way and inline post extensions.
- For reconfiguration and replacement use only.

PRODUCT CODE	PRICE	SIZE/ H	INCHES W	WEIGHT LBS	VOL FT ³
EVPVTFEA06	12	6.375	2.875	0.12	0.01
EVPVTFEA12	13	12.375	2.875	0.16	0.02
EVPVTFEA18	14	18.375	2.875	0.28	0.03
EVPVTFEA24	14	24.375	2.875	0.32	0.04
EVPVTFEA30	16	30.375	2.875	0.36	0.05
EVPVTFEA36	21	36.375	2.875	0.40	0.06
EVPVTFEA42	23	42.375	2.875	0.44	0.07
EVPVTFEA48	24	48.375	2.875	0.48	0.08
EVPVTFEA54	25	54.375	2.875	0.52	0.09
EVPVTFEA66	27	66.375	2.875	0.56	0.10
EVPVTFEA78	30	78.375	2.875	0.64	0.12
EVPVTFEA90	31	90.375	2.875	0.72	0.14

EVPTVA • Panel Trim Variable Height - Aluminum



- Attaches to the exposed end of the taller panel when 2 panels of different height meet in straight run.
- Must be ordered separately.

PRODUCT CODE	PRICE	SIZE/ H	INCHES W	WEIGHT LBS	VOL FT ³
EVPTVA06	23	5.621	2.875	0.10	0.03
EVPTVA12	26	11.621	2.875	0.20	0.03
EVPTVA18	34	18.621	2.875	0.22	0.04
EVPTVA24	40	23.621	2.875	0.20	0.10
EVPTVA30	53	29.621	2.875	0.20	0.15
EVPTVA36	61	35.621	2.875	0.30	0.20

EVPERTA • End of Run Trim - Aluminum



- Finishes the exposed connector at the end of a run of panels.
- Slotted connector not included.
- For reconfiguration and replacement use only.

PRODUCT CODE	PRICE	SIZE/ H	INCHES W	WEIGHT LBS	VOL FT ³
EVPERTA30	54	28.815	2.875	1.00	0.65
EVPERTA42	64	40.815	2.875	1.40	0.70
EVPERTA48	68	46.815	2.875	1.60	0.90
EVPERTA54	78	52.815	2.875	1.80	0.95
EVPERTA66	90	64.815	2.875	2.20	0.98
EVPERTA78	97	76.815	2.875	1.12	0.15
EVPERTA84	106	82.815	2.875	1.20	0.16
EVPERTA90	106	88.815	2.875	1.29	0.18

EVPTEA • Panel Extension Trim - Aluminum



- Attaches to bottom of exposed end of panel to provide extension for End-of-Run trim when using panel extensions.
- Does not include slotted connector or connecting hardware.

PRODUCT CODE	PRICE	SIZE/ H	INCHES W	WEIGHT LBS	VOL FT ³
EVPTEA06	23	6	2.875	0.08	0.03
EVPTEA12	26	12	2.875	0.10	0.03
EVPTEA18	34	18	2.875	0.12	0.03
EVPTEA24	40	24	2.875	0.20	0.60

EVPUETA12 • Upmount Extension Trim - Aluminum

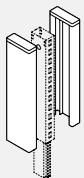

- Attaches to the Upmount Extension Connector EVPUECSA12 or to an Inline Connector EVPVC66 66" high.
- Used to finish the exposed Upmount Extension Connector on both sides.
- Priced in pairs.

PRODUCT CODE	PRICE	SIZE/ H	INCHES W	WEIGHT LBS	VOL FT ³
EVPUETA12	40	12	2.875	0.20	0.03

EVPUETA66 • End of Line Trim for Raised Storage – Aluminum

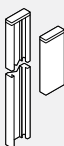

- Replaces 66" H end-of-stroke trim only.
- Includes EVPUETA12 Raised Storage Extension Trim and Raised Storage End Trim.
- Trim must be used in conjunction with slotted fittings.

PRODUCT CODE	PRICE	SIZE/ H	INCHES W	WEIGHT LBS	VOL FT ³
EVPUETA66	102	66	2.875	0.55	0.08

EVPIECH • 12 "h Channel for Center Mount Overhead



- 12" channel to attaches panel to the side of a pre-installed center mount overhead with screws.
- Includes 12 "h channel and connecting hardware.

PRODUCT CODE	PRICE	SIZE/INCHES			WEIGHT LBS	VOL FT ³
		H	W	D		
EVPIECH12	38	12	3		1.32	0.12

EVPTTA • Panel Top Trim Aluminum

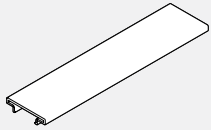

- Comes standard on all panels.
- Supplied at no charge.
- Field install no longer necessary.

PRODUCT CODE	PRICE	SIZE/ INCHES		WEIGHT LBS	VOL FT ³
		H	W		
EVPTTA18	13	18	2.875	0.18	0.03
EVPTTA24	16	24	2.875	0.22	0.04
EVPTTA30	23	30	2.875	0.29	0.05
EVPTTA36	25	36	2.875	0.30	0.06
EVPTTA42	29	42	2.875	0.34	0.07
EVPTTA48	34	48	2.875	0.38	0.08
EVPTTA54	37	54	2.875	0.42	0.09
EVPTTA60	43	60	2.875	0.46	0.10

EVPTNTA • Panel Top Notched Trim Aluminum

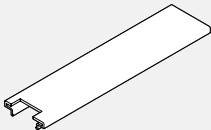

- Comes standard on all panels.
- Used when connecting a lower panel to a higher panel.
- To be used when shipping new panels with aluminum trim.
- Supplied at no charge when using panels in variable height configurations.
- Field install no longer necessary.

PRODUCT CODE	PRICE	SIZE/ INCHES		WEIGHT LBS	VOL FT ³
		H	W		
EVPTNTA18	14	18	2.875	0.18	0.03
EVPTNTA24	21	24	2.875	0.22	0.04
EVPTNTA30	24	30	2.875	0.26	0.05
EVPTNTA36	26	36	2.875	0.30	0.06
EVPTNTA42	30	42	2.875	0.34	0.07
EVPTNTA48	35	48	2.875	0.38	0.08
EVPTNTA54	38	54	2.875	0.42	0.09
EVPTNTA60	46	60	2.875	0.46	0.10

EVPTDNTA • Panel Top Double Notched Trim Aluminum

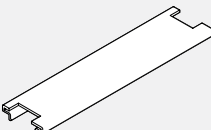

- Comes standard on all panels.
- Used when connecting a lower panel to two higher panels.
- To be used when shipping new panels with aluminum trim.
- Supplied at no charge when using panels in variable height configurations.
- Field install no longer necessary.

PRODUCT CODE	PRICE	SIZE/ INCHES		WEIGHT LBS	VOL FT ³
		H	W		
EVPTDNTA18	16	18	2.875	0.18	0.03
EVPTDNTA24	23	24	2.875	0.22	0.04
EVPTDNTA30	25	30	2.875	0.26	0.05
EVPTDNTA36	27	36	2.875	0.30	0.06
EVPTDNTA42	31	42	2.875	0.34	0.07
EVPTDNTA48	36	48	2.875	0.38	0.08
EVPTDNTA54	40	54	2.875	0.42	0.09
EVPTDNTA60	48	60	2.875	0.46	0.10

EVPTTCA - Aluminum Top Trim with Channel for Acoustic Grid

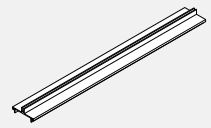

- Top trim with channel.
- Available in standard paint colors.
- Note: Trim can span inline connector, but not a post.

PRODUCT CODE	PRICE	SIZE/INCHES			WEIGHT LBS	VOL FT ³
		H	W	D		
EVPTTCA18	14	18	2 7/8	0.18	0.03	
EVPTTCA24	17	24	2 7/8	0.22	0.04	
EVPTTCA30	25	30	2 7/8	0.29	0.05	
EVPTTCA36	28	36	2 7/8	0.30	0.06	
EVPTTCA42	31	42	2 7/8	0.34	0.07	
EVPTTCA48	36	48	2 7/8	0.38	0.08	
EVPTTCA54	40	54	2 7/8	0.42	0.09	
EVPTTCA60	47	60	2 7/8	0.46	0.10	
EVPTTCA66	50	66	2 7/8	0.50	0.11	
EVPTTCA72	54	72	2 7/8	0.54	0.12	
EVPTTCA78	60	78	2 7/8	0.58	0.13	
EVPTTCA84	65	84	2 7/8	0.62	0.14	
EVPTTCA90	73	90	2 7/8	0.66	0.15	
EVPTTCA96	84	96	2 7/8	0.70	0.16	

EVSC12 • Slot Cover



- Covers the slots of a slotted connector between panels as well as a corner post and end-of-run kit.
- Sold by the foot and cut on site by the installers.
- To order the required length, calculate the sum of the length of all inline connectors (including the posts and end-of-run kit) and multiply by 2.

PRODUCT CODE	PRICE	SIZE/ INCHES		WEIGHT VOL	
		H	W	LBS	FT ³
EVSC12	5	12	1	0.01	0.01

EVECC310 • Wire Manager

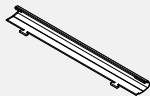

- Attaches to panels vertically between modules to provide enclosures for power or data cords.
- Sold in packages of 6.
- Can be overlapped to achieve required length.

PRODUCT CODE	PRICE	SIZE/ INCHES		WEIGHT VOL	
		H	W	LBS	FT ³
EVECC310	40	10	1	0.01	0.01

EVHLPF01 • Low Profile Foot

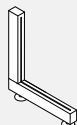

- Used to provide additional support to panel run without adding panels.
- Connects to inline connector or end of run at base of panels.

PRODUCT CODE	PRICE	SIZE/ INCHES			WEIGHT VOL	
		H	W	D	LBS	FT ³
EVHLPF01	100	11	11	1	2.6	0.07

EVCLVAR • Connector Variable Height Clamp

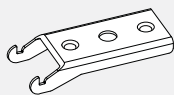

- Used for connecting two panels of variable height.

PRODUCT CODE	PRICE	SIZE/ INCHES			WEIGHT VOL	
		H	W	D	LBS	FT ³
EVCLVAR	9				0.5	0.01

EVPIECBS • Bridge Panel Inline Extension Connector



- Connects bridge panel to inline extension connector.
- Includes one bridge extension connector and connecting hardware.

PRODUCT CODE	PRICE	SIZE/INCHES			WEIGHT VOL		
		H	W	D	LBS	FT ³	
EVPIECBS06	29	31	6	3	3	1.00	0.06
EVPIECBS12	29	31	12	3	3	2.00	0.12
EVPIECBS18	34	37	18	3	3	3.00	0.18
EVPIECBS24	34	37	24	3	3	4.00	0.24

EVPEERBSA • Bridge Panel End of Run Extension Connector - Aluminum Trim



- Connects at end of run of bridge panel and can attach panel to fixed wall.
- Adds 1" to width of panel run.
- Provides slotted support for worksurfaces and hang on components up to 66" high.
- Includes one slotted bridge extension connector and connecting hardware and trim kit.

PRODUCT CODE	PRICE	SIZE/INCHES			WEIGHT VOL		
		H	W	D	LBS	FT ³	
EVPEERBSA06	34		6	3	3	1.00	0.06
EVPEERBSA12	34		12	3	3	2.00	0.12
EVPEERBSA18	52		18	3	3	3.00	0.18
EVPEERBSA24	52		24	3	3	4.00	0.24

EVPICBS • Bridge Panel Inline Connector without Aluminum Insert



- Connects two bridge panel to inline connector.
- Inline connector in middle between two bridge panels, above opening, using double clamp at bottom.
- Includes one bridge extension connector without aluminum insert and connecting hardware.

PRODUCT CODE	PRICE	SIZE/INCHES			WEIGHT VOL		
		H	W	D	LBS	FT ³	
EVPICBS06	32		6	3	3	1.00	0.06
EVPICBS12	32		12	3	3	2.00	0.12
EVPICBS18	38		18	3	3	3.00	0.18
EVPICBS24	38		24	3	3	4.00	0.24

EVPCEPB1 • Bridge Panel Corner Extension Post 1-way

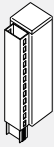

- Connects at end of a run of extension modules.
- Post and connecting hardware add 3.25" to power beam run.
- Includes one extension post, one slotted extension connectors for bridge panel, connecting hardware and trim kit.

PRODUCT CODE	PRICE	SIZE/INCHES			WEIGHT LBS	VOL FT ³
		H	W	D		
EVPCEPBSA106	75	6	3	3	2.00	0.07
EVPCEPBSA112	75	12	3	3	4.00	0.14
EVPCEPBSA118	97	18	3	3	6.00	0.21
EVPCEPBSA124	97	24	3	3	8.00	0.14

EVPCEPB4 • Bridge Panel Corner Extension Post 4-way

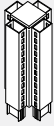

- Connects four bridge panels in 90 degree configuration.
- Post and connecting hardware add 3.25" to power beam run.
- Includes one extension post, four one slotted extension connectors for bridge panel, connecting hardware and trim kit.

PRODUCT CODE	PRICE	SIZE/INCHES			WEIGHT LBS	VOL FT ³
		H	W	D		
EVPCEPBS406	100	6	3	3	4.00	0.09
EVPCEPBS412	100	12	3	3	8.00	0.18
EVPCEPBS418	157	18	3	3	12.00	0.27
EVPCEPBS424	157	24	3	3	16.00	0.36

EVPCEPB3 • Bridge Panel Corner Extension Post 3-way

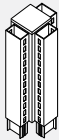

- Connects three bridge panels in 90 degree configuration.
- Post and connecting hardware add 3.25" to power beam run.
- Includes one extension post, three one slotted extension connectors for bridge panel, connecting hardware and trim kit.

PRODUCT CODE	PRICE	SIZE/INCHES			WEIGHT LBS	VOL FT ³
		H	W	D		
EVPCEPBSA306	89	6	3	3	3.00	0.08
EVPCEPBSA312	89	12	3	3	6.00	0.16
EVPCEPBSA318	139	18	3	3	9.00	0.24
EVPCEPBSA324	139	24	3	3	12.00	0.32

EVPCEPB2 • Bridge Panel Corner Extension Post 2-way

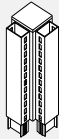

- Connects two bridge panels in 90 degree configuration.
- Post and connecting hardware add 3.25" to power beam run.
- Includes one extension post, two one slotted extension connectors for bridge panel, connecting hardware and trim kit.

PRODUCT CODE	PRICE	SIZE/INCHES			WEIGHT LBS	VOL FT ³
		H	W	D		
EVPCEPBSA206	76	6	3	3	2.00	0.07
EVPCEPBSA212	76	12	3	3	4.00	0.14
EVPCEPBSA218	122	18	3	3	6.00	0.21
EVPCEPBSA224	122	24	3	3	8.00	0.14

EVPCEIPBSA2 • Bridge Panel Inline 2-way Post Extension

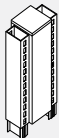

- Connects two bridge panels in straight run.
- Post and connecting hardware add 3.25" to power beam run.
- Includes one extension post, two slotted extension connectors for bridge panel, connecting hardware and trim kit.

PRODUCT CODE	PRICE	SIZE/INCHES			WEIGHT LBS	VOL FT ³
		H	W	D		
EVPCEIPBSA206	76	6	3	3	2.00	0.07
EVPCEIPBSA212	76	12	3	3	4.00	0.14
EVPCEIPBSA218	122	18	3	3	6.00	0.21
EVPCEIPBSA224	122	24	3	3	8.00	0.14

NO RACEWAY PANELS • TECHNICAL INFORMATION

- Evolve panels are 2 7/8" thick. They are available in four (5) basic heights: 30", 42", 48", 54" and 66" and eight (8) widths: 18" to 60" in 6" increments.
- Individual fabric covered acoustic modules incorporated into a rigid steel frame.
- Opposite side of each module may have a different fabric within the same grade at no upcharge.
- If different grades of fabric are used on one panel, the entire panel must be priced at highest grade.
- A low profile top cap is included.
- No panel creep.
- 12" high and 24" high modules of 2 types (fabric and laminate) are available for field installation. Contact your Customer Service Representative.
- Laminate for laminate panels cannot be replaced in the field, complete module must be ordered.

PANELS • GUIDELINES FOR ORDERING PRODUCT

The price list uses a numbering system with meaningful alphanumeric characters to create a simple-to-understand product number. This makes specifying the product much easier and more accurate.

EXAMPLE OF PANEL CODE

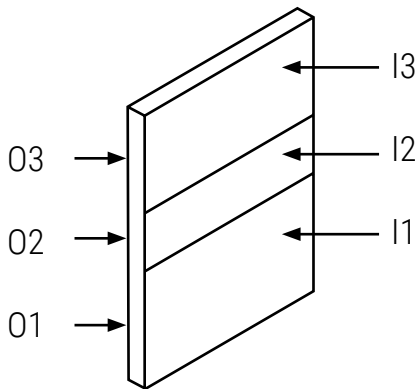
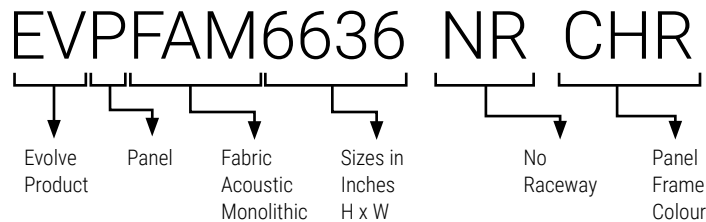

I1	AN50	Inside Fabric Position #1
I2	AN50	Inside Fabric Position #2
I3	AN50	Inside Fabric Position #3
O1	BE21	Outside Fabric Position #1
O2	BE21	Outside Fabric Position #2
O3	BE21	Outside Fabric Position #3

HOW TO SPECIFY

- Specify Evolve panel type and size by code.
- Specify panel frame finish - ie. CHR (Charcoal).
- Specify all necessary panel fabric options.

NOTE: If different grades of fabric are used on one panel, the entire panel must be priced out at the higher grade.

EVPFA-NR • Segmented (No Raceway) Panel

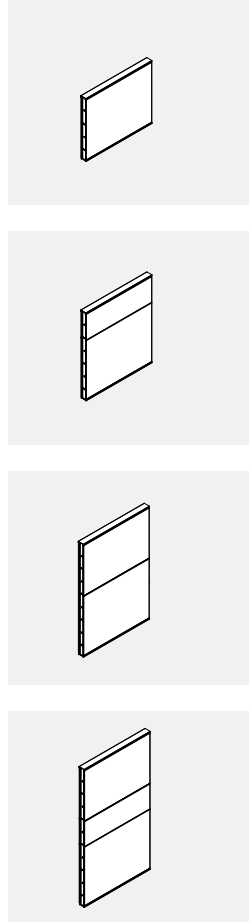

- Segmented (No Raceway) panel incorporates fabric modules within steel frame.
- There is no base raceway in No Raceway Panels to accommodate electric.
- **No Raceway connectors to be used.**
- Fabric covered modules are tackable and acoustical.
- Each side of fabric module may have different fabric within the same grade at no charge.
- If different grades of fabric are used, the entire module must be price at highest grade.
- Aluminum low profile top and bottom cap is included.
- Stackability: Evolve panels can be increased in height in 6", 12", 24" increments. See module listing for part numbers.

PRODUCT CODE	PRICE		SIZE/ INCHES			WEIGHT		VOL FT ³
	GR 1	GR 2	H	W	D	LBS		
EVPFA3018NR	305	317	30	18	2.875	15.38	1.23	
EVPFA3024NR	318	372	30	24	2.875	18.20	1.63	
EVPFA3030NR	352	372	30	30	2.875	21.76	2.00	
EVPFA3036NR	378	401	30	36	2.875	24.80	2.38	
EVPFA3042NR	408	434	30	42	2.875	26.49	2.76	
EVPFA3048NR	451	482	30	48	2.875	32.00	3.13	
EVPFA3054NR	486	520	30	54	2.875	35.31	3.51	
EVPFA3060NR	522	562	30	60	2.875	38.20	3.89	
EVPFA4218NR	338	354	42	18	2.875	20.58	1.71	
EVPFA4224NR	354	382	42	24	2.875	24.60	2.31	
EVPFA4230NR	412	443	42	30	2.875	29.35	2.81	
EVPFA4236NR	446	482	42	36	2.875	35.60	3.38	
EVPFA4242NR	509	548	42	42	2.875	39.29	3.92	
EVPFA4248NR	548	593	42	48	2.875	43.20	4.45	
EVPFA4254NR	607	657	42	54	2.875	47.52	4.98	
EVPFA4260NR	665	721	42	60	2.875	51.60	5.52	
EVPFA4818NR	363	385	48	18	2.875	23.98	2.19	
EVPFA4824NR	397	431	48	24	2.875	27.80	2.94	
EVPFA4830NR	452	490	48	30	2.875	33.15	3.62	
EVPFA4836NR	505	550	48	36	2.875	37.40	4.31	
EVPFA4842NR	570	625	48	42	2.875	40.69	4.99	
EVPFA4848NR	634	694	48	48	2.875	48.20	5.67	
EVPFA4854NR	691	758	48	54	2.875	52.92	6.35	
EVPFA4860NR	740	814	48	60	2.875	57.40	7.03	
EVPFA5418NR	363	385	54	18	2.875	23.98	2.19	
EVPFA5424NR	397	431	54	24	2.875	27.80	2.94	
EVPFA5430NR	452	490	54	30	2.875	33.15	3.62	
EVPFA5436NR	505	550	54	36	2.875	37.40	4.31	
EVPFA5442NR	570	625	54	42	2.875	40.69	4.99	
EVPFA5448NR	634	694	54	48	2.875	48.20	5.67	
EVPFA5454NR	691	758	54	54	2.875	52.92	6.35	
EVPFA5460NR	740	814	54	60	2.875	57.40	7.03	
EVPFA6618NR	455	486	66	18	2.875	29.98	2.68	
EVPFA6624NR	353	536	66	24	2.875	35.00	3.58	
EVPFA6630NR	544	593	66	30	2.875	41.54	4.40	
EVPFA6636NR	638	697	66	36	2.875	49.00	5.23	
EVPFA6642NR	722	790	66	42	2.875	54.29	6.06	
EVPFA6648NR	774	850	66	48	2.875	60.20	6.08	
EVPFA6654NR	842	926	66	54	2.875	65.93	7.70	
EVPFA6660NR	909	1001	66	60	2.875	71.60	8.53	

EVPFAM-NR • Monolithic (No Raceway) Panel

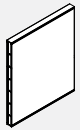

- Monolithic (No Raceway) panel incorporates fabric modules within steel frame.
- There is no base raceway in No Raceway Panels to accommodate electric.
- **No Raceway connectors to be used.**
- Fabric covered modules are tackable and acoustical.
- Each side of fabric module may have different fabric within the same grade at no charge.
- If different grades of fabric are used, the entire module must be price at highest grade.
- Aluminum low profile top and bottom cap is included.
- Stackability: Evolve panels can be increased in height in 6", 12", 24" increments. See module listing for part numbers.

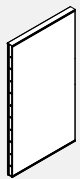
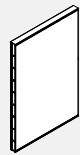
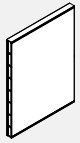

PRODUCT CODE	PRICE		SIZE/ INCHES			WEIGHT	VOL
	GR 1	GR 2	H	W	D	LBS	FT ³
EVPFAM4218NR	333	364	42	18	2.875	20.58	1.71
EVPFAM4224NR	355	394	42	24	2.875	23.40	2.31
EVPFAM4230NR	406	450	42	30	2.875	26.96	2.85
EVPFAM4236NR	436	487	42	36	2.875	30.00	3.38
EVPFAM4242NR	483	543	42	42	2.875	31.69	3.92
EVPFAM4248NR	525	593	42	48	2.875	37.20	4.45
EVPFAM4254NR	579	653	42	54	2.875	40.51	4.98
EVPFAM4260NR	629	711	42	60	2.875	43.40	5.52
EVPFAM4818NR	340	371	48	18	2.875	21.38	1.92
EVPFAM4824NR	374	410	48	24	2.875	24.40	2.62
EVPFAM4830NR	431	476	48	30	2.875	27.76	3.23
EVPFAM4836NR	469	520	48	36	2.875	30.80	3.85
EVPFAM4842NR	524	584	48	42	2.875	32.49	4.45
EVPFAM4848NR	572	637	48	48	2.875	37.80	5.06
EVPFAM4854NR	630	704	48	54	2.875	41.31	5.66
EVPFAM4860NR	684	767	48	60	2.875	44.20	6.27
EVPFAM5418NR	342	374	54	18	2.875	24.58	2.19
EVPFAM5424NR	376	415	54	24	2.875	27.40	2.94
EVPFAM5430NR	437	482	54	30	2.875	30.96	3.62
EVPFAM5436NR	486	541	54	36	2.875	34.00	4.31
EVPFAM5442NR	545	605	54	42	2.875	35.69	4.99
EVPFAM5448NR	591	661	54	48	2.875	41.20	5.67
EVPFAM5454NR	651	728	54	54	2.875	44.51	6.35
EVPFAM5460NR	712	796	54	60	2.875	47.40	7.03
EVPFAM6618NR	425	455	66	18	2.875	27.58	2.68
EVPFAM6624NR	463	503	66	24	2.875	30.40	3.58
EVPFAM6630NR	524	573	66	30	2.875	33.96	4.40
EVPFAM6636NR	608	663	66	36	2.875	37.00	5.23
EVPFAM6642NR	684	743	66	42	2.875	38.69	6.06
EVPFAM6648NR	743	811	66	48	2.875	44.20	6.88
EVPFAM6654NR	826	900	66	54	2.875	47.51	7.70
EVPFAM6660NR	909	991	66	60	2.875	50.40	8.53
EVPFAM9018NR	752	805	90	18	2.875	38.18	3.43
EVPFAM9024NR	810	873	90	24	2.875	42.72	4.58
EVPFAM9030NR	900	985	90	30	2.875	47.99	5.65
EVPFAM9036NR	1047	1139	90	36	2.875	52.75	6.73

EVPH1S-NR • Laminate (No Raceway) Panel Single Sided

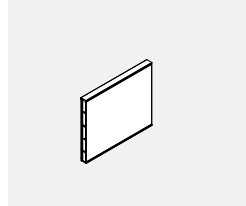

- Laminate (No Raceway) panel incorporates single sided laminate modules within steel frame.
- Opposite side is fabric covered.
- Laminate faces on all modules provide durable, washable surface on Single sided of the panel.
- Available in high pressure laminate only.
- If wood grain is selected, grain runs horizontally.
- There is no base raceway in No Raceway Panels to accommodate electric.

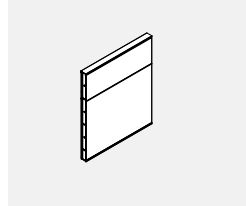

- **No Raceway connectors to be used.**
- If different grades of fabric are used, the entire module must be price at highest grade.
- Aluminum low profile top and bottom cap is included.
- Stackability: Evolve panels can be increased in height in 6", 12", 24" increments. See module listing for part numbers.

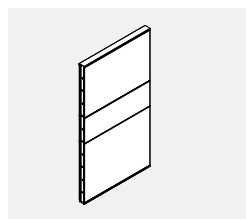
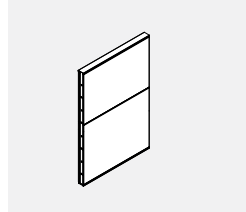

PRODUCT CODE	PRICE		SIZE/ INCHES			WEIGHT	VOL
	GR 1	GR 2	H	W	D	LBS	FT ³
EVPH1S3018NR	373	380	30	18	2.875	15.88	1.23
EVPH1S3024NR	448	456	30	24	2.875	18.70	1.63
EVPH1S3030NR	523	535	30	30	2.875	22.26	2.00
EVPH1S3036NR	593	610	30	36	2.875	24.85	2.38
EVPH1S3042NR	676	689	30	42	2.875	26.99	2.76
EVPH1S3048NR	732	747	30	48	2.875	32.05	3.13
EVPH1S3054NR	814	830	30	54	2.875	35.81	3.51
EVPH1S3060NR	891	908	30	60	2.875	38.07	3.89
EVPH1S4218NR	443	482	42	18	2.875	21.38	1.71
EVPH1S4224NR	530	546	42	24	2.875	22.13	2.31
EVPH1S4230NR	619	634	42	30	2.875	30.15	2.81
EVPH1S4236NR	713	733	42	36	2.875	36.40	3.38
EVPH1S4242NR	806	829	42	42	2.875	40.09	3.92
EVPH1S4248NR	879	903	42	48	2.875	44.00	4.45
EVPH1S4254NR	976	1001	42	54	2.875	48.32	4.98
EVPH1S4260NR	1068	1100	42	60	2.875	52.40	5.52
EVPH1S5418NR	522	537	54	18	2.875	24.98	2.19
EVPH1S5424NR	630	648	54	24	2.875	28.80	2.94
EVPH1S5430NR	741	761	54	30	2.875	34.15	3.62
EVPH1S5436NR	849	872	54	36	2.875	38.40	4.31
EVPH1S5442NR	960	987	54	42	2.875	41.69	4.99
EVPH1S5448NR	1050	1083	54	48	2.875	49.20	5.67
EVPH1S5454NR	1167	1201	54	54	2.875	53.92	6.35
EVPH1S5460NR	1284	1325	54	60	2.875	58.40	7.03
EVPH1S6618NR	648	665	66	18	2.875	31.29	2.68
EVPH1S6624NR	781	802	66	24	2.875	36.30	3.58
EVPH1S6630NR	911	937	66	30	2.875	42.84	4.40
EVPH1S6636NR	1052	1084	66	36	2.875	50.30	5.23
EVPH1S6642NR	1198	1233	66	42	2.875	55.59	6.06
EVPH1S6648NR	1303	1343	66	48	2.875	61.50	6.08
EVPH1S6654NR	1448	1494	66	54	2.875	67.23	7.70
EVPH1S6660NR	1595	1646	66	60	2.875	72.90	8.53

EVPH2S-NR • Laminate (No Raceway) Panel Double Sided

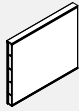

- Laminate (No Raceway) panel incorporates double sided laminate modules within steel frame
- Laminate faces on all modules provide durable, washable surface on both sides of the panel
- Available in high pressure laminate only
- If wood grain is selected, grain runs horizontally
- There is no base raceway in No Raceway Panels to accommodate electric
- **No Raceway connectors to be used.**
- Aluminum low profile top and bottom cap is included
- Stackability: Evolve panels can be increased in height in 6", 12", 24" increments. See module listing for part numbers.

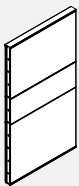
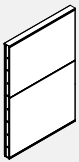
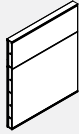

PRODUCT CODE	PRICE	SIZE/ INCHES			WEIGHT LBS	VOL FT ³
		H	W	D		
EVPH2S3018NR	417	30	18	2.875	16.38	1.23
EVPH2S3024NR	510	30	24	2.875	19.20	1.63
EVPH2S3030NR	604	30	30	2.875	22.76	2.00
EVPH2S3036NR	689	30	36	2.875	25.80	2.38
EVPH2S3042NR	785	30	42	2.875	27.49	2.76
EVPH2S3048NR	877	30	48	2.875	33.00	3.13
EVPH2S3054NR	972	30	54	2.875	36.31	3.51
EVPH2S3060NR	1052	30	60	2.875	39.20	3.89
EVPH2S4218NR	497	42	18	2.875	22.18	1.71
EVPH2S4224NR	604	42	24	2.875	26.20	2.31
EVPH2S4230NR	712	42	30	2.875	30.95	2.81
EVPH2S4236NR	827	42	36	2.875	37.20	3.38
EVPH2S4242NR	943	42	42	2.875	40.89	3.92
EVPH2S4248NR	1056	42	48	2.875	42.80	4.45
EVPH2S4254NR	1162	42	54	2.875	49.12	4.98
EVPH2S4260NR	1267	42	60	2.875	53.20	5.52
EVPH2S5418NR	581	54	18	2.875	25.98	2.19
EVPH2S5424NR	714	54	24	2.875	29.80	2.94
EVPH2S5430NR	849	54	30	2.875	35.15	3.62
EVPH2S5436NR	984	54	36	2.875	39.40	4.31
EVPH2S5442NR	1123	54	42	2.875	42.69	4.99
EVPH2S5448NR	1266	54	48	2.875	50.20	5.67
EVPH2S5454NR	1394	54	54	2.875	52.92	6.35
EVPH2S5460NR	1517	54	60	2.875	59.40	7.03
EVPH2S6618NR	732	66	18	2.875	32.58	2.68
EVPH2S6624NR	903	66	24	2.875	37.60	3.58
EVPH2S6630NR	1068	66	30	2.875	44.14	4.40
EVPH2S6636NR	1241	66	36	2.875	51.60	5.23
EVPH2S6642NR	1428	66	42	2.875	56.89	6.06
EVPH2S6648NR	1595	66	48	2.875	62.80	6.08
EVPH2S6654NR	1764	66	54	2.875	68.53	7.70
EVPH2S6660NR	1927	66	60	2.875	74.20	8.53

EVPXGT-NR • Fully Glazed (No Raceway) Panel

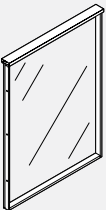

- **EVPXGTNR - Fully Glazed Monolithic No Raceway Panel.**
- There is no base raceway in No Raceway Panels to accommodate electric.
- No Raceway connectors to be used.
- Fully Glazed Monolithic No Raceway panel are incorporated in solid steel frame.
- Standard in clear (CLR).
- Frosted glass (FRST) 40% upcharge.
- Size 90"x36"W is maximum size allowed.
- Panel height to align with standard door height.
- Aluminum low profile top and bottom cap is included.

PRODUCT CODE	PRICE	SIZE/ INCHES			WEIGHT LBS	VOL FT ³
		H	W	D		
EVPXGT9018NR	784	90	18	2.875	15.88	1.23
EVPXGT9024NR	895	90	24	2.875	18.70	1.63
EVPXGT9030NR	1016	90	30	2.875	22.26	2.00
EVPXGT9036NR	1100	90	36	2.875	24.85	2.38

EVPGTNR-NR • Fully Glazed Segmented (No Raceway) Panel

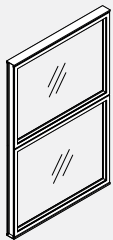

- **Fully Glazed Segmented No Raceway Panel with solid steel frame..**
- There is no base raceway in No Raceway Panels to accommodate electrical.
- No Raceway connectors to be used.
- Standard in clear (CLR).
- Frosted glass (FRST) 40% upcharge.
- Aluminum low profile top and bottom cap is included.

PRODUCT CODE	PRICE	SIZE/ INCHES			WEIGHT LBS	VOL FT ³
		H	W	D		
EVPGT4818NR	625	48	18	2.875	35.19	2.19
EVPGT4824NR	765	48	24	2.875	49.76	2.94
EVPGT4830NR	846	48	30	2.875	52.08	3.62
EVPGT4836NR	925	48	36	2.875	64.54	4.31
EVPGT4842NR	1024	48	42	2.875	72.62	4.99
EVPGT4848NR	1143	48	48	2.875	78.11	5.67
EVPGT4854NR	1258	48	54	2.875	86.04	6.35
EVPGT4860NR	1372	48	60	2.875	94.09	7.03

EVPIC-NR • Inline Connector (No Raceway) Panel



- Connects two No Raceway panel in straight run.
- Provides slotted support for worksurfaces and hang on components.
- Includes one slotted connector with leveling glide and connecting hardware.
- Connectors available without slots, as a special at no extra charge. Contact customer support.

PRODUCT CODE	PRICE	SIZE/INCHES			WEIGHT LBS	VOL FT ³
		H	W	D		
EVPIC30NR	63	30	2		3.30	0.05
EVPIC42NR	67	42	2		4.60	0.07
EVPIC48NR	69	48	2		5.25	0.07
EVPIC54NR	74	54	2		5.90	0.09
EVPIC66NR	83	66	2		7.20	0.10

EVPIC-NR • Inline Connector (No Raceway) Panel



- Connects two 90" H No Raceway panel in straight run.
- Includes one slotted connector with leveling glide and connecting hardware.
- Connectors are without slots.
- To be used only with 90" H NR Glazed Panels

PRODUCT CODE	PRICE	SIZE/INCHES			WEIGHT LBS	VOL FT ³
		H	W	D		
EVPIC90NR	117	90	2		11.2	0.19

EVPVC-NR • Inline Variable Height Connector (No Raceway) Panel



- Connects two No Raceway panels of differing height in straight run.
- Connector must reference taller panel.
- Can be used for any variation of pane height.
- Variable height trim must be ordered separately (see EVPTVA).
- Provides slotted support for worksurfaces and hang on components.
- Includes one slotted connector with leveling glide and connecting hardware.
- Connectors available without slots, as a special at no extra charge. Contact customer support.

PRODUCT CODE	PRICE	SIZE/INCHES			WEIGHT LBS	VOL FT ³
		H	W	D		
EVPVC42NR	74	42	2		4.60	0.07
EVPVC48NR	77	48	2		5.25	0.07
EVPVC54NR	78	54	2		5.90	0.09
EVPVC66NR	88	66	2		7.20	0.10

EVPERA-NR • End of Run Post Kit for (No Raceway) Panel



- Connects at end of No Raceway panel and can attach to a panel to fixed wall.
- Adds 1" to width of panel run.
- Provides slotted support for worksurfaces and hang on components.
- Includes one slotted connector with leveling glide and connecting hardware and trim kit.
- Can be attached to face of another panel to provide off modular connection.
- Connectors available without slots, as a special at no extra charge. Contact customer support.

PRODUCT CODE	PRICE	SIZE/INCHES			WEIGHT LBS	VOL FT ³
		H	W	D		
EVPERA30NR	78	30	2		3.30	0.07
EVPERA42NR	94	42	2		4.60	0.10
EVPERA48NR	100	48	2		5.25	0.10
EVPERA54NR	112	54	2		5.90	0.18
EVPERA66NR	126	66	2		7.20	0.22

EVPERA-NR • End of Run Post Kit for (No Raceway) Panel



- Connects two 90" H No Raceway panel and can attach to a panel to fixed wall.
- Adds 1" width of panel run.
- Includes one slotted connector with leveling glide and connecting hardware and trim kit.
- Can be attached to face of another panel to provide off modular connection.
- Connectors are without slots.
- To be used only with 90" H NR Glazed Panels

PRODUCT CODE	PRICE	SIZE/INCHES			WEIGHT LBS	VOL FT ³
		H	W	D		
EVPERA90NR	162	90	2		11.2	0.19

EVPCPA2-NR • Two Way Corner Post (No Raceway) Panel



- Connects two No Raceway panel of equal height in 90 degree configuration.
- Post and connecting hardware add 3.25" to power beam run.
- Provides slotted support for worksurfaces and hang on components.
- Includes post, panel connectors and power beam connectors, post with trim all around, levelling glide, hardware and trim kit.
- Connectors available without slots, as a special at no extra charge. Contact customer support.

PRODUCT CODE	PRICE	SIZE/INCHES			WEIGHT LBS	VOL FT ³
		H	W	D		
EVPCPA230NR	162	30	2.875		8.50	0.31
EVPCPA242NR	207	42	2.875		11.50	0.43
EVPCPA248NR	217	48	2.875		11.50	0.54
EVPCPA254NR	251	54	2.875		15.00	0.61
EVPCPA266NR	299	66	2.875		19.00	0.75

EVPCPA2-NR • Two Way Corner Post (No Raceway) Panel



- Connects two No Raceway panel of equal height in 90 degree configuration.
- Post and connecting hardware add 3.25" to power beam run.
- Includes post, panel connectors and power beam connectors, post with trim all around, levelling glide, hardware and trim kit.
- Connectors are without slots.
- To be used only with 90" H NR Glazed Panels

PRODUCT CODE	PRICE	SIZE/INCHES			WEIGHT LBS	VOL FT ³
		H	W	D		
EVPCPA290NR	412	90	2.875		27	1.03

EVPCPA3-NR • Three Way Corner Post (No Raceway) Panel



- Connects three No Raceway panel of equal height in "T" configuration.
- Post and connecting hardware add 3.25" to power beam run.
- Provides slotted support for worksurfaces and hang on components.
- Includes post, panel connectors and power beam connectors, post with trim all around, levelling glide, hardware and trim kit.
- Connectors available without slots, as a special at no extra charge. Contact customer support.

PRODUCT CODE	PRICE	SIZE/INCHES			WEIGHT LBS	VOL FT ³
		H	W	D		
EVPCPA330NR	195	30	2.875		11.80	0.36
EVPCPA342NR	260	42	2.875		16.10	0.50
EVPCPA348NR	286	48	2.875		18.75	0.61
EVPCPA354NR	317	54	2.875		20.50	0.70
EVPCPA366NR	373	66	2.875		26.20	0.85

EVPCPA3-NR • Three Way Corner Post (No Raceway) Panel



- Connects three No Raceway panel of equal height in "T" configuration.
- Post and connecting hardware add 3.25" to power beam run.
- Includes post, panel connectors and power beam connectors, post with trim all around, levelling glide, hardware and trim kit.
- Connectors are without slots.
- To be used only with 90" H NR Glazed Panels

PRODUCT CODE	PRICE	SIZE/INCHES			WEIGHT LBS	VOL FT ³
		H	W	D		
EVPCPA390NR	500	90	2.875		38.2	1.17

EVPCPA4-NR • Four Way Corner Post (No Raceway) Panel



- Connects four No Raceway panel of equal height in "+" configuration.
- Post and connecting hardware add 3.25" to power beam run.
- Provides slotted support for worksurfaces and hang on components.
- Includes post, panel connectors and power beam connectors, post with trim all around, levelling glide, hardware and trim kit.
- Connectors available without slots, as a special at no extra charge. Contact customer support.

PRODUCT CODE	PRICE	SIZE/INCHES			WEIGHT LBS	VOL FT ³
		H	W	D		
EVPCPA430NR	213	30	2.875		15.5	0.40
EVPCPA442NR	279	42	2.875		21.00	0.57
EVPCPA448NR	307	48	2.875		24.00	0.68
EVPCPA454NR	339	54	2.875		26.50	0.79
EVPCPA466NR	397	66	2.875		33.20	0.95

EVPCPA4-NR • Four Way Corner Post (No Raceway) Panel



- Connects three No Raceway panel of equal height in "+" configuration.
- Post and connecting hardware add 3.25" to power beam run.
- Includes post, panel connectors and power beam connectors, post with trim all around, levelling glide, hardware and trim kit.
- Connectors are without slots.
- To be used only with 90" H NR Glazed Panels

PRODUCT CODE	PRICE	SIZE/INCHES			WEIGHT LBS	VOL FT ³
		H	W	D		
EVPCPA490NR	510	90	2.875		49.2	1.31

EVPIPA2-NR • Inline Two Way Corner Post (No Raceway Panel)



- Connects two No Raceway panel of equal height in straight run.
- Post and connecting hardware add 3.25" to power beam run.
- Provides slotted support for worksurfaces and hang on components.
- Includes post, panel connectors and power beam connectors, post with trim all around, levelling glide, hardware and trim kit.
- Connectors available without slots, as a special at no extra charge. Contact customer support.

PRODUCT CODE	PRICE	SIZE/INCHES			WEIGHT LBS	VOL FT ³
		H	W	D		
EVPIPA230NR	162	30	2.875		8.20	0.31
EVPIPA242NR	207	42	2.875		11.50	0.43
EVPIPA248NR	217	48	2.875		13.50	0.54
EVPIPA254NR	251	54	2.875		15.00	0.61
EVPIPA266NR	299	66	2.875		19.00	0.75

EVPIPA2-NR • Inline Two Way Corner Post (No Raceway Panel)



- Connects three No Raceway panel of equal height in a straight run.
- Post and connecting hardware add 3.25" to power beam run.
- Includes post, panel connectors and power beam connectors, post with trim all around, levelling glide, hardware and trim kit.
- Connectors are without slots.
- To be used only with 90" H NR Glazed Panels

PRODUCT CODE	PRICE	SIZE/INCHES			WEIGHT LBS	VOL FT ³
		H	W	D		
EVPIPA290NR	433	90	2.875		27	1.03

EVPCPA1-NR • One Way Corner Post (No Raceway Panel)



- Connects at end of No Raceway panel run in place of EVPERA-End of run post kit.
- Should not be used to attach pane to fixed wall.
- Post and connecting hardware add 3.25" to power beam run.
- Provides slotted support for worksurfaces and hang on components.
- Includes post, panel connectors and power beam connectors, post with trim all around, levelling glide, hardware and trim kit.
- Connectors available without slots, as a special at no extra charge. Contact customer support.

PRODUCT CODE	PRICE	SIZE/INCHES			WEIGHT LBS	VOL FT ³
		H	W	D		
EVPCPA130NR	103	30	2.875		4.97	0.24
EVPCPA142NR	117	42	2.875		6.93	0.33
EVPCPA148NR	139	48	2.875		7.93	0.38
EVPCPA154NR	160	54	2.875		8.93	0.43
EVPCPA166NR	199	66	2.875		10.87	0.53

EVPCPA1-NR • Inline One Way Corner Post (No Raceway Panel)



- Connects three No Raceway panel of equal height in a straight run.
- Should not be used to attach pane to fixed wall.
- Post and connecting hardware add 3.25" to power beam run.
- Includes post, panel connectors and power beam connectors, post with trim all around, levelling glide, hardware and trim kit.
- Connectors are without slots.
- To be used only with 90" H NR Glazed Panels

PRODUCT CODE	PRICE	SIZE/INCHES			WEIGHT LBS	VOL FT ³
		H	W	D		
EVPCPA190NR	284	90	2.875		14.87	0.67

EVVPC-PNR • Inline variable height connector Panel (No Raceway Panel)



- Connects Panel to No Raceway panels of differing height in straight run.
- Connector must reference taller panel.
- Can be used for any variation of panel height.
- Variable height trim must be ordered separately (see EVPTVA).
- Provides slotted support for worksurfaces and hang on components.
- Includes one slotted connector with leveling glide and connecting hardware.
- Connectors available without slots, as a special at no extra charge. Contact your Customer Service Representative.

PRODUCT CODE	PRICE	SIZE/INCHES			WEIGHT LBS	VOL FT ³
		H	W	D		
EVVPC42PNR	74	42	2		4.60	0.07
EVVPC48PNR	77	48	2		5.25	0.07
EVVPC54PNR	78	54	2		5.90	0.09
EVVPC66PNR	88	66	2		7.20	0.10

EVPCPA2-PNR • Two Way Corner Post (No Raceway Panel)



- Connects No Raceway panel and Panel of equal height in 90 degree configuration.
- Post and connecting hardware add 3.25" to power beam run.
- Provides slotted support for worksurfaces and hang on components.
- Includes post, panel connectors and power beam connectors, post with trim all around, levelling glide, hardware and trim kit.
- Connectors available without slots, as a special at no extra charge. Contact customer support.

PRODUCT CODE	PRICE	SIZE/INCHES			WEIGHT LBS	VOL FT ³
		H	W	D		
EVPCPA230PNR	162	30	2.875		8.50	0.31
EVPCPA242PNR	207	42	2.875		11.50	0.43
EVPCPA248PNR	217	48	2.875		11.50	0.54
EVPCPA254PNR	251	54	2.875		15.00	0.61
EVPCPA266PNR	299	66	2.875		19.00	0.75

EVPCPA3-NR • Three Way Corner Post (No Raceway Panel)



- Connects two No Raceway panel and Panel of equal height in "T" configuration.
- Post and connecting hardware add 3.25" to power beam run.
- Provides slotted support for worksurfaces and hang on components.
- Includes post, panel connectors and power beam connectors, post with trim all around, levelling glide, hardware and trim kit.
- Connectors available without slots, as a special at no extra charge. Contact customer support.

PRODUCT CODE	PRICE	SIZE/INCHES			WEIGHT LBS	VOL FT ³
		H	W	D		
EVPCPA330PNR	195	30	2.875		11.80	0.36
EVPCPA342PNR	260	42	2.875		16.10	0.50
EVPCPA348PNR	286	48	2.875		18.75	0.61
EVPCPA354PNR	317	54	2.875		20.50	0.70
EVPCPA366PNR	373	66	2.875		26.20	0.85

EVPIC-PNR • Inline connector Panel (No Raceway Panel)



- Connects Panel to No Raceway panel in straight run
- Provides slotted support for worksurfaces and hang on components
- Includes one slotted connector with leveling glide and connecting hardware
- Connectors available without slots, as a special at no extra charge. Contact your Customer Service Representative.

PRODUCT CODE	PRICE	SIZE/INCHES			WEIGHT LBS	VOL FT ³
		H	W	D		
EVPIC30PNR	63	30	2		3.30	0.05
EVPIC42PNR	67	42	2		4.60	0.07
EVPIC48PNR	69	48	2		5.25	0.07
EVPIC54PNR	74	54	2		5.90	0.09
EVPIC66PNR	83	66	2		7.20	0.10

EVPIC-PNR • Inline connector Panel (No Raceway Panel)



- Connects 90" H No Raceway panel to 90" H door in straight run.
- Includes one non slotted connector with leveling glide and connecting hardware.
- Connectors are without slots.
- Note: To be used only with 90" H NR Glazed Panels and 90" H door.

PRODUCT CODE	PRICE	SIZE/INCHES			WEIGHT LBS	VOL FT ³
		H	W	D		
EVPIC90PNR	117	90	2		11.2	0.19

EVPCPA4-NR • Four Way Corner Post (No Raceway Panel)



- Connects two No Raceway panel and two Panel of equal height in "+" configuration.
- Post and connecting hardware add 3.25" to power beam run.
- Provides slotted support for worksurfaces and hang on components.
- Includes post, panel connectors and power beam connectors, post with trim all around, levelling glide, hardware and trim kit
- Connectors available without slots, as a special at no extra charge. Contact customer support.

PRODUCT CODE	PRICE	SIZE/INCHES			WEIGHT LBS	VOL FT ³
		H	W	D		
EVPCPA430PNR	213	30	2.875		15.5	0.40
EVPCPA442PNR	279	42	2.875		21.00	0.57
EVPCPA448PNR	307	48	2.875		24.00	0.68
EVPCPA454PNR	339	54	2.875		26.50	0.79
EVPCPA466PNR	397	66	2.875		33.20	0.95

EVPIPA2-NR • Inline Two Way Corner Post (No Raceway Panel)



- Connects No Raceway panel and Panel of equal height in straight run.
- Post and connecting hardware add 3.25" to power beam run.
- Provides slotted support for worksurfaces and hang on components.
- Includes post, panel connectors and power beam connectors, post with trim all around, levelling glide, hardware and trim kit.
- Connectors available without slots, as a special at no extra charge. Contact customer support.
- Note: Inline two way post must be used when No Panel and Panel are next to each other in run

PRODUCT CODE	PRICE	SIZE/INCHES			WEIGHT LBS	VOL FT ³
		H	W	D		
EVPIPA230PNR	162	30	2.875		8.20	0.31
EVPIPA242PNR	207	42	2.875		11.50	0.43
EVPIPA248PNR	217	48	2.875		13.50	0.54
EVPIPA254PNR	251	54	2.875		15.00	0.61
EVPIPA266PNR	299	66	2.875		19.00	0.75

EVPERCHxxNR • Laminate Panel Connector with U Channel (No Raceway Panel)



- U channel attaches with screws to laminate end panel or laminate middle panel.
- Evolve NO Raceway Panels attach to connector.
- U Channel is welded to a No Raceway Connector.
- Includes No Raceway connector with U channel and hardware.

PRODUCT CODE	PRICE	SIZE/INCHES			WEIGHT LBS	VOL FT ³
		H	W	D		
EVPERCH42NR	133	42	2.875		4.60	0.14
EVPERCH48NR	140	48	2.875		5.09	0.18
EVPERCH54NR	151	54	2.875		6.75	0.22

EVPPXGT • Freestanding Glazed Monolithic Privacy Panel

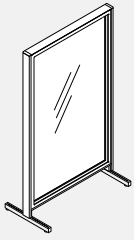

- Includes panel with two connectors with T legs with glides and end of run trims.
- Available in standard clear (CLR) tempered glass
- Available in standard frosted (FRST) tempered glass
- 22"d T-Legs (9.5" extension on each side of panel)
- Glazing is replaceable on site.

PRODUCT CODE	PRICE		SIZE/INCHES			WEIGHT LBS	VOL FT ³
	CLR	FRST	H	W	D		
EVPPXGT4218	590	711	42	18	2.875	50.53	2.46
EVPPXGT4224	650	795	42	24	2.875	58.14	3.06
EVPPXGT4230	704	873	42	30	2.875	65.96	3.6
EVPPXGT4236	760	948	42	36	2.875	69.3	4.13
EVPPXGT4242	820	1035	42	42	2.875	73.38	4.67
EVPPXGT5418	688	836	54	18	2.875	56.19	2.99
EVPPXGT5424	759	935	54	24	2.875	70.76	3.38
EVPPXGT5430	825	1025	54	30	2.875	73.08	4.42
EVPPXGT5436	887	1117	54	36	2.875	85.54	5.11
EVPPXGT5442	958	1217	54	42	2.875	93.62	5.79
EVPPXGT6618	794	970	66	18	2.875	62.74	3.48
EVPPXGT6624	871	1080	66	24	2.875	70.81	4.38
EVPPXGT6630	948	1189	66	30	2.875	78.63	4.79
EVPPXGT6636	1021	1291	66	36	2.875	86.52	5.38
EVPPXGT6642	1108	1410	66	42	2.875	92.66	6.38

EVPPXGT-F • Freestanding Glazed Monolithic Privacy Panel with Flat Foot

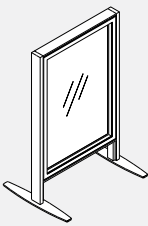

- Includes panel with two connectors with flat foot and end of run trims
- Available in standard clear (CLR) tempered glass
- Available in standard frosted (FRST) tempered glass
- Flat foot does not extend past end trim, no gaps between end trims
- 22"d T-Legs (9.5" extension on each side of panel)
- Glazing is replaceable on site.

PRODUCT CODE	PRICE		SIZE/INCHES			WEIGHT LBS	VOL FT ³
	CLR	FRST	H	W	D		
EVPPXGT4218F	590	711	42	18	2.875	50.53	2.46
EVPPXGT4224F	650	795	42	24	2.875	58.14	3.06
EVPPXGT4230F	704	873	42	30	2.875	65.96	3.6
EVPPXGT4236F	760	948	42	36	2.875	69.3	4.13
EVPPXGT4242F	820	1035	42	42	2.875	73.38	4.67
EVPPXGT5418F	688	836	54	18	2.875	56.19	2.99
EVPPXGT5424F	759	935	54	24	2.875	70.76	3.38
EVPPXGT5430F	825	1025	54	30	2.875	73.08	4.42
EVPPXGT5436F	887	1117	54	36	2.875	85.54	5.11
EVPPXGT5442F	958	1217	54	42	2.875	93.62	5.79
EVPPXGT6618F	794	970	66	18	2.875	62.74	3.48
EVPPXGT6624F	871	1080	66	24	2.875	70.81	4.38
EVPPXGT6630F	948	1189	66	30	2.875	78.63	4.79
EVPPXGT6636F	1021	1291	66	36	2.875	86.52	5.38
EVPPXGT6642F	1108	1410	66	42	2.875	92.66	6.38

EVPPXGT-FS • Freestanding Glazed Monolithic Privacy Panel with Shared Flat Foot

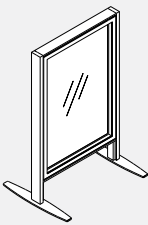

- Includes panel with two connectors with flat foot and end of run trims
- Available in standard clear (CLR) tempered glass
- Available in standard frosted (FRST) tempered glass
- Shared flat foot with connector in middle of flat foot
- 22"d T-Legs (9.5" extension on each side of panel)
- Glazing is replaceable on site.

PRODUCT CODE	PRICE		SIZE/INCHES			WEIGHT LBS	VOL FT ³
	CLR	FRST	H	W	D		
EVPPXGT4218FS	590	711	42	18	2.875	50.53	2.46
EVPPXGT4224FS	650	795	42	24	2.875	58.14	3.06
EVPPXGT4230FS	704	873	42	30	2.875	65.96	3.6
EVPPXGT4236FS	760	948	42	36	2.875	69.3	4.13
EVPPXGT4242FS	820	1035	42	42	2.875	73.38	4.67
EVPPXGT5418FS	688	836	54	18	2.875	56.19	2.99
EVPPXGT5424FS	759	935	54	24	2.875	70.76	3.38
EVPPXGT5430FS	825	1025	54	30	2.875	73.08	4.42
EVPPXGT5436FS	887	1117	54	36	2.875	85.54	5.11
EVPPXGT5442FS	958	1217	54	42	2.875	93.62	5.79
EVPPXGT6618FS	794	970	66	18	2.875	62.74	3.48
EVPPXGT6624FS	871	1080	66	24	2.875	70.81	4.38
EVPPXGT6630FS	948	1189	66	30	2.875	78.63	4.79
EVPPXGT6636FS	1021	1291	66	36	2.875	86.52	5.38
EVPPXGT6642FS	1108	1410	66	42	2.875	92.66	6.38

EVPPXGT-M • Mobile Glazed Monolithic Panel

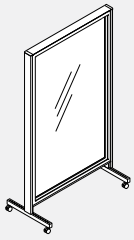

- Includes panel with two connectors with T legs with castors and end of run trims
- Available in standard clear (CLR) tempered glass
- Available in standard frosted (FRST) tempered glass
- Available in standard writeable (WRW) glass.
- 22"d T-Legs (9.5" extension on each side of panel)
- 1" locking casters
- Glazing is replaceable on site.

PRODUCT CODE	PRICE			SIZE/INCHES			WEIGHT LBS	VOL FT ³
	CLR	FRST	WRW	H	W	D		
EVPPXGT4218M	663	783	-	42	18	2.875	50.53	2.46
EVPPXGT4224M	724	868	-	42	24	2.875	58.14	3.06
EVPPXGT4230M	777	946	-	42	30	2.875	65.96	3.6
EVPPXGT4236M	833	1021	-	42	36	2.875	69.3	4.13
EVPPXGT4242M	894	1108	-	42	42	2.875	73.38	4.67
EVPPXGT5418M	760	909	1213	54	18	2.875	56.19	2.99
EVPPXGT5424M	832	1008	1398	54	24	2.875	70.76	3.38
EVPPXGT5430M	898	1098	1574	54	30	2.875	73.08	4.42
EVPPXGT5436M	959	1189	1749	54	36	2.875	85.54	5.11
EVPPXGT5442M	1032	1290	1933	54	42	2.875	93.62	5.79
EVPPXGT6618M	867	1043	1426	66	18	2.875	62.74	3.48
EVPPXGT6624M	944	1153	1641	66	24	2.875	70.81	4.38
EVPPXGT6630M	1021	1262	1854	66	30	2.875	78.63	4.79
EVPPXGT6636M	1093	1364	2060	66	36	2.875	86.52	5.38
EVPPXGT6642M	1180	1484	2287	66	42	2.875	92.66	6.38

EVPPGT • Freestanding Segmented Glazed Privacy Panels

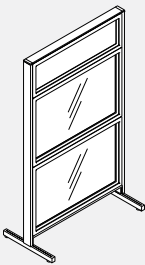

- Includes panel with two connectors with T legs with glides and end of run trims
- Available in standard clear (CLR) tempered glass
- Available in standard frosted (FRST) tempered glass
- 22"d T-Legs (9.5" extension on each side of panel)
- Glazing is replaceable on site.

PRODUCT CODE	PRICE			SIZE/INCHES			WEIGHT LBS	VOL FT ³
	CLR	FRST	WRW	H	W	D		
EVPPGT5424	733	909	-	54	24	2.875	70.8	3.38
EVPPGT5430	805	1011	-	54	30	2.875	73.1	4.42
EVPPGT5436	877	1109	-	54	36	2.875	85.5	5.11
EVPPGT5442	954	1220	-	54	42	2.875	93.6	5.79
EVPPGT5448	1029	1326	-	54	48	2.875	99.1	6.47
EVPPGT5454	1109	1438	-	54	54	2.875	107	7.15
EVPPGT5460	1178	1536	-	54	60	2.875	115.1	7.83
EVPPGT6624	918	1156	-	66	24	2.875	78.63	4.38
EVPPGT6630	1004	1279	-	66	30	2.875	86.52	4.79
EVPPGT6636	1144	1475	-	66	36	2.875	92.66	5.38
EVPPGT6642	1241	1611	-	66	42	2.875	98.19	6.38
EVPPGT6648	1341	1751	-	66	48	2.875	105.48	7.68
EVPPGT6654	1450	1904	-	66	54	2.875	112.52	8.5
EVPPGT6660	1570	2069	-	66	60	2.875	129.3	9.33

EVPPGT-M • Mobile Segmented Glazed Privacy Panels

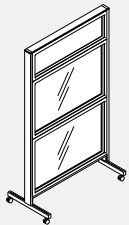

- Includes panel with two connectors with T legs with castors and end of run trims
- Available in standard clear (CLR) tempered glass
- Available in standard frosted (FRST) tempered glass
- 22"d T-Legs (9.5" extension on each side of panel)
- 1" locking casters
- Glazing is replaceable on site.

PRODUCT CODE	PRICE			SIZE/INCHES			WEIGHT LBS	VOL FT ³
	CLR	FRST	WRW	H	W	D		
EVPPGT5424M	801	977	-	54	24	2.875	70.8	3.38
EVPPGT5430M	874	1079	-	54	30	2.875	73.1	4.42
EVPPGT5436M	947	1178	-	54	36	2.875	85.5	5.11
EVPPGT5442M	1022	1288	-	54	42	2.875	93.6	5.79
EVPPGT5448M	1099	1394	-	54	48	2.875	99.1	6.47
EVPPGT5454M	1178	1507	-	54	54	2.875	107	7.15
EVPPGT5460M	1246	1604	-	54	60	2.875	115.1	7.83
EVPPGT6624M	986	1224	-	66	24	2.875	78.63	4.38
EVPPGT6630M	1073	1348	-	66	30	2.875	86.52	4.79
EVPPGT6636M	1212	1543	-	66	36	2.875	92.66	5.38
EVPPGT6642M	1310	1679	-	66	42	2.875	98.19	6.38
EVPPGT6648M	1409	1819	-	66	48	2.875	105.48	7.68
EVPPGT6654M	1519	1972	-	66	54	2.875	112.52	8.5
EVPPGT6660M	1639	2138	-	66	60	2.875	129.3	9.33

EVPPHGT • Freestanding Segmented Glazed and Laminate Privacy Panels - Two Sides

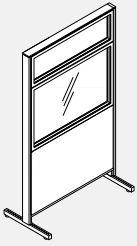

- 30" base panel with laminate faces both sides provides for durable and washable surfaces
- Available in standard clear (CLR) tempered glass
- Available in standard frosted (FRST) tempered glass
- 22"d T-Legs (9.5" extension on each side of panel)
- Glazing is replaceable on site.

PRODUCT CODE	PRICE		SIZE / INCHES			WEIGHT LBS	VOL FT ³
	CLR	FRST	H	W	D		
EVPPHGT5424	777	870	54	24	2.875	55.8	3.38
EVPPHGT5430	862	975	54	30	2.875	62.8	4.42
EVPPHGT5436	950	1083	54	36	2.875	69.3	5.11
EVPPHGT5442	1037	1187	54	42	2.875	74.1	5.79
EVPPHGT5448	1123	1289	54	48	2.875	83.1	6.47
EVPPHGT5454	1216	1401	54	54	2.875	89.4	7.15
EVPPHGT5460	1298	1498	54	60	2.875	95.5	7.83
EVPPHGT6624	960	1088	66	24	2.875	70.81	4.38
EVPPHGT6630	1062	1210	66	30	2.875	78.63	4.79
EVPPHGT6636	1197	1372	66	36	2.875	86.52	5.38
EVPPHGT6642	1300	1496	66	42	2.875	92.66	6.38
EVPPHGT6648	1405	1621	66	48	2.875	98.19	7.68
EVPPHGT6654	1524	1764	66	54	2.875	105.48	8.5
EVPPHGT6660	1666	1933	66	60	2.875	116.2	9.33

EVPPHGT-M • Mobile Segmented Glazed and Laminate Privacy Panels - Two Sides

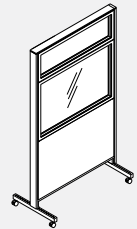

- 30" base panel with laminate faces both sides provides for durable and washable surfaces
- Available in standard clear (CLR) tempered glass
- Available in standard frosted (FRST) tempered glass
- 22"d T-Legs (9.5" extension on each side of panel)
- 1" locking casters
- Glazing is replaceable on site.

PRODUCT CODE	PRICE		SIZE / INCHES			WEIGHT LBS	VOL FT ³
	CLR	FRST	H	W	D		
EVPPHGT5424M	845	938	54	24	2.875	55.8	3.38
EVPPHGT5430M	930	1043	54	30	2.875	62.8	4.42
EVPPHGT5436M	1018	1152	54	36	2.875	69.3	5.11
EVPPHGT5442M	1105	1255	54	42	2.875	74.1	5.79
EVPPHGT5448M	1192	1357	54	48	2.875	83.1	6.47
EVPPHGT5454M	1284	1470	54	54	2.875	89.4	7.15
EVPPHGT5460M	1366	1566	54	60	2.875	95.5	7.83
EVPPHGT6624M	1028	1156	66	24	2.875	70.81	4.38
EVPPHGT6630M	1130	1278	66	30	2.875	78.63	4.79
EVPPHGT6636M	1265	1441	66	36	2.875	86.52	5.38
EVPPHGT6642M	1368	1564	66	42	2.875	92.66	6.38
EVPPHGT6648M	1473	1690	66	48	2.875	98.19	7.68
EVPPHGT6654M	1592	1832	66	54	2.875	105.48	8.5
EVPPHGT6660M	1733	2001	66	60	2.875	116.2	9.33

EVPPHGTU • Freestanding Segmented Glazed and Laminate Privacy Panels - Two Sides

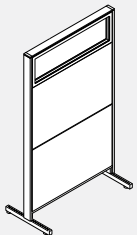

- Laminate faces both sides provides for durable and washable surfaces
- Available in standard clear (CLR) tempered glass
- Available in standard frosted (FRST) tempered glass
- 22"d T-Legs (9.5" extension on each side of panel)
- 12" Glazed segment
- Glazing is replaceable on site.

PRODUCT CODE	PRICE		SIZE / INCHES			WEIGHT LBS	VOL FT ³
	CLR	FRST	H	W	D		
EVPPHGTU5424	894	1017	54	24	2.875	49.2	3.38
EVPPHGTU5430	994	1133	54	30	2.875	55.8	4.42
EVPPHGTU5436	1094	1257	54	36	2.875	62.8	5.11
EVPPHGTU5442	1194	1374	54	42	2.875	69.3	5.79
EVPPHGTU5448	1294	1495	54	48	2.875	74.1	6.47
EVPPHGTU5454	1403	1622	54	54	2.875	83.1	7.15
EVPPHGTU5460	1502	1744	54	60	2.875	89.4	7.83
EVPPHGTU6624	1001	1137	66	24	2.875	53.34	4.38
EVPPHGTU6630	1118	1277	66	30	2.875	60.76	4.79
EVPPHGTU6636	1259	1447	66	36	2.875	68.18	5.38
EVPPHGTU6642	1372	1583	66	42	2.875	76.2	6.38
EVPPHGTU6648	1485	1720	66	48	2.875	87.76	7.68
EVPPHGTU6654	1616	1877	66	54	2.875	95.45	8.5
EVPPHGTU6660	1757	2046	66	60	2.875	99.7	9.33

EVPPHGTU-M • Mobile Segmented Glazed and Laminate Privacy Panels - Two Sides

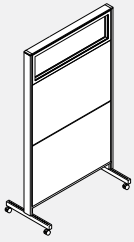

- Laminate faces both sides provides for durable and washable surfaces
- Available in standard clear (CLR) tempered glass
- Available in standard frosted (FRST) tempered glass
- 22"d T-Legs (9.5" extension on each side of panel)
- 1" locking casters
- 12" Glazed segment
- Glazing is replaceable on site.

PRODUCT CODE	PRICE		SIZE/INCHES			WEIGHT LBS	VOL FT ³
	CLR	FRST	H	W	D		
EVPPHGTU5424M	962	1086	54	24	2.875	49.2	3.38
EVPPHGTU5430M	1062	1201	54	30	2.875	55.8	4.42
EVPPHGTU5436M	1162	1325	54	36	2.875	62.8	5.11
EVPPHGTU5442M	1262	1442	54	42	2.875	69.3	5.79
EVPPHGTU5448M	1363	1563	54	48	2.875	74.1	6.47
EVPPHGTU5454M	1471	1691	54	54	2.875	83.1	7.15
EVPPHGTU5460M	1570	1812	54	60	2.875	89.4	7.83
EVPPHGTU6624M	1069	1205	66	24	2.875	53.34	4.38
EVPPHGTU6630M	1187	1345	66	30	2.875	60.76	4.79
EVPPHGTU6636M	1327	1515	66	36	2.875	68.18	5.38
EVPPHGTU6642M	1441	1652	66	42	2.875	76.2	6.38
EVPPHGTU6648M	1554	1788	66	48	2.875	87.76	7.68
EVPPHGTU6654M	1684	1945	66	54	2.875	95.45	8.5
EVPPHGTU6660M	1825	2114	66	60	2.875	99.7	9.33

EVPPH2S • Freestanding Segmented Laminate Privacy Panels - Two Sides

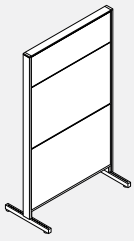

- All laminate faces both sides provides for durable and washable surfaces
- 22"d T-Legs (9.5" extension on each side of panel)

PRODUCT CODE	PRICE	SIZE/INCHES			WEIGHT LBS	VOL FT ³
		H	W	D		
EVPPH2S5424	818	54	24	2.875	50.8	3.38
EVPPH2S5430	918	54	30	2.875	56.2	4.42
EVPPH2S5436	1023	54	36	2.875	60.4	5.11
EVPPH2S5442	1121	54	42	2.875	63.7	5.79
EVPPH2S5448	1216	54	48	2.875	71.2	6.47
EVPPH2S5454	1320	54	54	2.875	73.9	7.15
EVPPH2S5460	1414	54	60	2.875	80.4	7.83
EVPPH2S6624	990	66	24	2.875	62.8	4.38
EVPPH2S6630	1121	66	30	2.875	69.3	4.79
EVPPH2S6636	1267	66	36	2.875	76.8	5.38
EVPPH2S6642	1394	66	42	2.875	82.1	6.38
EVPPH2S6648	1516	66	48	2.875	88	7.68
EVPPH2S6654	1645	66	54	2.875	93.7	8.5
EVPPH2S6660	1782	66	60	2.875	95.2	9.33

EVPPH2S-M • Mobile Segmented Laminate Privacy Panels - Two Sides

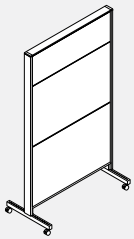

- All laminate faces both sides provides for durable and washable surfaces
- Includes panel with two connectors with T legs with castors and end of run trims
- 22"d T-Legs (9.5" extension on each side of panel)
- 1" locking casters

PRODUCT CODE	PRICE	SIZE/INCHES			WEIGHT LBS	VOL FT ³
		H	W	D		
EVPPH2S5424M	886	54	24	2.875	50.8	3.38
EVPPH2S5430M	986	54	30	2.875	56.2	4.42
EVPPH2S5436M	1091	54	36	2.875	60.4	5.11
EVPPH2S5442M	1189	54	42	2.875	63.7	5.79
EVPPH2S5448M	1284	54	48	2.875	71.2	6.47
EVPPH2S5454M	1389	54	54	2.875	73.9	7.15
EVPPH2S5460M	1482	54	60	2.875	80.4	7.83
EVPPH2S6624M	1060	66	24	2.875	62.8	4.38
EVPPH2S6630M	1189	66	30	2.875	69.3	4.79
EVPPH2S6636M	1336	66	36	2.875	76.8	5.38
EVPPH2S6642M	1462	66	42	2.875	82.1	6.38
EVPPH2S6648M	1585	66	48	2.875	88	7.68
EVPPH2S6654M	1713	66	54	2.875	93.7	8.5
EVPPH2S6660M	1850	66	60	2.875	95.2	9.33

EVPPF2W • Freestanding Segmented Write Board Privacy Panels

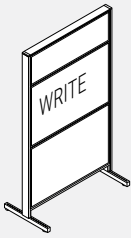

- Writing surface is built into the top module on both sides of the panel, alleviating the need for a panel-mounted Writeboard.
- Use of erasable Writeboard markers only.
- 22"d T-Legs (9.5" extension on each side of panel)

PRODUCT CODE	PRICE		SIZE/INCHES			WEIGHT LBS	VOL FT ³
	GR1	GR2	H	W	D		
EVPPF2W5424	790	805	54	24	2.875	49.8	3.38
EVPPF2W5430	885	905	54	30	2.875	55.2	4.42
EVPPF2W5436	981	1000	54	36	2.875	59.4	5.11
EVPPF2W5442	1073	1100	54	42	2.875	62.7	5.79
EVPPF2W5448	1181	1211	54	48	2.875	70.2	6.47
EVPPF2W5454	1283	1329	54	54	2.875	74.9	7.15
EVPPF2W5460	1375	1414	54	60	2.875	79.4	7.83
EVPPF2W6624	955	970	66	24	2.875	57.8	4.38
EVPPF2W6630	1119	1139	66	30	2.875	62.8	4.79
EVPPF2W6636	1261	1283	66	36	2.875	69.3	5.38
EVPPF2W6642	1393	1417	66	42	2.875	76.8	6.38
EVPPF2W6648	1537	1566	66	48	2.875	82.1	7.68
EVPPF2W6654	1669	1714	66	54	2.875	88	8.5
EVPPF2W6660	1835	1867	66	60	2.875	98.3	9.33

EVPPF2W-M • Mobile Segmented Write Board Privacy Panels

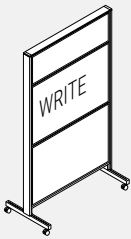

- Writing surface is built into the top module on both sides of the panel, alleviating the need for a panel-mounted Writeboard.
- Use of erasable Writeboard markers only.
- 22"d T-Legs (9.5" extension on each side of panel)
- 1" locking casters

PRODUCT CODE	PRICE		SIZE/INCHES			WEIGHT LBS	VOL FT ³
	GR1	GR2	H	W	D		
EVPPF2W5424M	858	874	54	24	2.875	49.8	3.38
EVPPF2W5430M	954	973	54	30	2.875	55.2	4.42
EVPPF2W5436M	1049	1068	54	36	2.875	59.4	5.11
EVPPF2W5442M	1142	1168	54	42	2.875	62.7	5.79
EVPPF2W5448M	1250	1279	54	48	2.875	70.2	6.47
EVPPF2W5454M	1351	1397	54	54	2.875	74.9	7.15
EVPPF2W5460M	1443	1482	54	60	2.875	79.4	7.83
EVPPF2W6624M	1023	1038	66	24	2.875	57.8	4.38
EVPPF2W6630M	1188	1208	66	30	2.875	62.8	4.79
EVPPF2W6636M	1329	1351	66	36	2.875	69.3	5.38
EVPPF2W6642M	1461	1485	66	42	2.875	76.8	6.38
EVPPF2W6648M	1605	1634	66	48	2.875	82.1	7.68
EVPPF2W6654M	1737	1783	66	54	2.875	88	8.5
EVPPF2W6660M	1904	1935	66	60	2.875	98.3	9.33

EVPPH2W • Freestanding Segmented Write Board and Laminate Privacy Panels

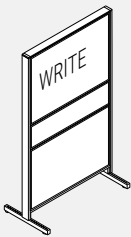

- 30" base panel with laminate faces both sides provides for durable and washable surfaces
- Writing surface is built into upper modules on both sides of the panel, alleviating the need for a panel-mounted Writeboard.
- Use of erasable Writeboard markers only.
- 22"d T-Legs (9.5" extension on each side of panel)

PRODUCT CODE	PRICE	SIZE/INCHES			WEIGHT LBS	VOL FT ³
		H	W	D		
EVPPH2W5424	868	54	24	2.875	50.8	3.38
EVPPH2W5430	982	54	30	2.875	56.2	4.42
EVPPH2W5436	1099	54	36	2.875	60.4	5.11
EVPPH2W5442	1209	54	42	2.875	63.7	5.79
EVPPH2W5448	1315	54	48	2.875	71.2	6.47
EVPPH2W5454	1434	54	54	2.875	73.9	7.15
EVPPH2W5460	1540	54	60	2.875	80.4	7.83
EVPPH2W6624	1024	66	24	2.875	62.8	4.38
EVPPH2W6630	1214	66	30	2.875	69.34	4.79
EVPPH2W6636	1388	66	36	2.875	76.8	5.38
EVPPH2W6642	1527	66	42	2.875	82.09	6.38
EVPPH2W6648	1672	66	48	2.875	88	7.68
EVPPH2W6654	1819	66	54	2.875	93.73	8.5
EVPPH2W6660	1971	66	60	2.875	95.2	9.33

EVPPH2W-M • Mobile Segmented Write Board and Laminate Privacy Panels

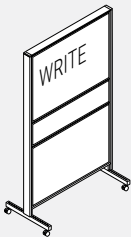

- 30" base panel with laminate faces both sides provides for durable and washable surfaces
- Writing surface is built into upper modules on both sides of the panel, alleviating the need for a panel-mounted Writeboard.
- Use of erasable Writeboard markers only.
- 22"d T-Legs (9.5" extension on each side of panel)

PRODUCT CODE	PRICE	SIZE/INCHES			WEIGHT LBS	VOL FT ³
		H	W	D		
EVPPH2W5424M	936	54	24	2.875	50.8	3.38
EVPPH2W5430M	1050	54	30	2.875	56.2	4.42
EVPPH2W5436M	1167	54	36	2.875	60.4	5.11
EVPPH2W5442M	1277	54	42	2.875	63.7	5.79
EVPPH2W5448M	1383	54	48	2.875	71.2	6.47
EVPPH2W5454M	1502	54	54	2.875	73.9	7.15
EVPPH2W5460M	1608	54	60	2.875	80.4	7.83
EVPPH2W6624M	1092	66	24	2.875	62.8	4.38
EVPPH2W6630M	1283	66	30	2.875	69.34	4.79
EVPPH2W6636M	1456	66	36	2.875	76.8	5.38
EVPPH2W6642M	1595	66	42	2.875	82.09	6.38
EVPPH2W6648M	1740	66	48	2.875	88	7.68
EVPPH2W6654M	1888	66	54	2.875	93.73	8.5
EVPPH2W6660M	2039	66	60	2.875	95.2	9.33

EVPRGLA • Acoustic Grid - 60" wide

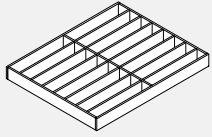

Configuration: 30" - 30"

- PET felt Acoustic Grid to be installed on top of Evolve panels.
- Acoustic Grid kit includes felt pieces, aluminum channel and all necessary hardware.
- PET felt slats run from side to side.
- PET felt pieces available in standard PET felt colours.
- Top trim with channel and beam above opening to be ordered separately.
- Shipped KD.
- For a different felt color for the outer PET frame, choose the code with a D at the end.

PRODUCT CODE	PRICE	SIZE/INCHES			WEIGHT LBS	VOL FT ³
		H	W	D		
EVPRGLA4860	1976	5.5	60	48	18.25	9.2
EVPRGLA6060	2342	5.5	60	60	19.02	11.5
EVPRGLA7260	2709	5.5	60	72	22.04	13.8
EVPRGLA8460	3074	5.5	60	84	25.06	16.0
EVPRGLA9060	3258	5.5	60	90	26.57	17.2
EVPRGLA9660	3468	5.5	60	96	28.29	18.3
EVPRGLA4860D	1976	5.5	60	48	18.25	9.2
EVPRGLA6060D	2342	5.5	60	60	19.02	11.5
EVPRGLA7260D	2709	5.5	60	72	22.04	13.8
EVPRGLA8460D	3074	5.5	60	84	25.06	16.0
EVPRGLA9060D	3258	5.5	60	90	26.57	17.2
EVPRGLA9660D	3468	5.5	60	96	28.29	18.3

EVPRGLA • Acoustic Grid - 72" wide

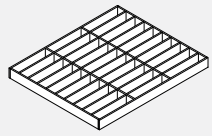

Configuration: 24" - 24" - 24"

- PET felt Acoustic Grid to be installed on top of Evolve panels.
- Acoustic Grid kit includes felt pieces, aluminum channel and all necessary hardware.
- PET felt slats run from side to side.
- PET felt pieces available in standard PET felt colours.
- Top trim with channel and beam above opening to be ordered separately.
- Shipped KD.
- For a different felt color for the outer PET frame, choose the code with a D at the end.

PRODUCT CODE	PRICE	SIZE/INCHES			WEIGHT LBS	VOL FT ³
		H	W	D		
EVPRGLA4872	2378	5.5	72	48	20.10	11.0
EVPRGLA6072	2821	5.5	72	60	23.96	13.8
EVPRGLA7272	3263	5.5	72	72	27.81	16.5
EVPRGLA8472	3705	5.5	72	84	31.67	19.3
EVPRGLA9072	3927	5.5	72	90	33.60	20.6
EVPRGLA9672	4176	5.5	72	96	35.75	22.0
EVPRGLA4872D	2378	5.5	72	48	20.10	11.0
EVPRGLA6072D	2821	5.5	72	60	23.96	13.8
EVPRGLA7272D	3263	5.5	72	72	27.81	16.5
EVPRGLA8472D	3705	5.5	72	84	31.67	19.3
EVPRGLA9072D	3927	5.5	72	90	33.60	20.6
EVPRGLA9672D	4176	5.5	72	96	35.75	22.0

EVPRGLA • Acoustic Grid - 84" wide

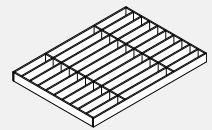

Configuration: 24" - 36" - 24"

- PET felt Acoustic Grid to be installed on top of Evolve panels.
- Acoustic Grid kit includes felt pieces, aluminum channel and all necessary hardware.
- PET felt slats run from side to side.
- PET felt pieces available in standard PET felt colours.
- Top trim with channel and beam above opening to be ordered separately.
- Shipped KD.
- For a different felt color for the outer PET frame, choose the code with a D at the end.

PRODUCT CODE	PRICE	SIZE/INCHES			WEIGHT LBS	VOL FT ³
		H	W	D		
EVPRGLA4884	2657	5.5	84	48	22.15	12.8
EVPRGLA6084	3147	5.5	84	60	26.35	16.0
EVPRGLA7284	3636	5.5	84	72	30.54	19.3
EVPRGLA8484	4124	5.5	84	84	34.74	22.5
EVPRGLA9084	4368	5.5	84	90	36.83	24.1
EVPRGLA9684	4640	5.5	84	96	39.14	25.7
EVPRGLA4884D	2657	5.5	84	48	22.15	12.8
EVPRGLA6084D	3147	5.5	84	60	26.35	16.0
EVPRGLA7284D	3636	5.5	84	72	30.54	19.3
EVPRGLA8484D	4124	5.5	84	84	34.74	22.5
EVPRGLA9084D	4368	5.5	84	90	36.83	24.1
EVPRGLA9684D	4640	5.5	84	96	39.14	25.7

EVPRGLA • Acoustic Grid - 90" wide

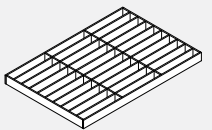

Configuration: 30" - 30" - 30"

- PET felt Acoustic Grid to be installed on top of Evolve panels.
- Acoustic Grid kit includes felt pieces, aluminum channel and all necessary hardware.
- PET felt slats run from side to side.
- PET felt pieces available in standard PET felt colours.
- Top trim with channel and beam above opening to be ordered separately.
- Shipped KD.
- For a different felt color for the outer PET frame, choose the code with a D at the end.

PRODUCT CODE	PRICE	SIZE/INCHES			WEIGHT LBS	VOL FT ³
		H	W	D		
EVPRGLA4890	2759	5.5	90	48	23.27	13.8
EVPRGLA6090	3271	5.5	90	60	27.65	17.2
EVPRGLA7290	3784	5.5	90	72	30.04	20.6
EVPRGLA8490	4296	5.5	90	84	36.42	24.1
EVPRGLA9090	4553	5.5	90	90	38.62	25.8
EVPRGLA9690	4837	5.5	90	96	41.01	27.5
EVPRGLA4890D	2759	5.5	90	48	23.27	13.8
EVPRGLA6090D	3271	5.5	90	60	27.65	17.2
EVPRGLA7290D	3784	5.5	90	72	30.04	20.6
EVPRGLA8490D	4296	5.5	90	84	36.42	24.1
EVPRGLA9090D	4553	5.5	90	90	38.62	25.8
EVPRGLA9690D	4837	5.5	90	96	41.01	27.5

EVPRGLA • Acoustic Grid - 96" wide

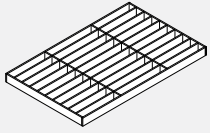

Configuration: 30"- 36"- 30"

- PET felt Acoustic Grid to be installed on top of Evolve panels.
- Acoustic Grid kit includes felt pieces, aluminum channel and all necessary hardware.
- PET felt slats run from side to side.
- PET felt pieces available in standard PET felt colours.
- Top trim with channel and beam above opening to be ordered separately.
- Shipped KD.
- For a different felt color for the outer PET frame, choose the code with a D at the end.

PRODUCT CODE	PRICE	SIZE/INCHES			WEIGHT LBS	VOL FT ³
		H	W	D		
EVPRGLA4896	2963	5.5	96	48	24.47	14.7
EVPRGLA6096	3500	5.5	96	60	29.02	18.3
EVPRGLA7296	4036	5.5	96	72	33.56	22.0
EVPRGLA8496	4570	5.5	96	84	38.11	25.7
EVPRGLA9096	4839	5.5	96	90	40.38	27.5
EVPRGLA9696	5132	5.5	96	96	42.86	29.3
EVPRGLA4896D	2963	5.5	96	48	24.47	14.7
EVPRGLA6096D	3500	5.5	96	60	29.02	18.3
EVPRGLA7296D	4036	5.5	96	72	33.56	22.0
EVPRGLA8496D	4570	5.5	96	84	38.11	25.7
EVPRGLA9096D	4839	5.5	96	90	40.38	27.5
EVPRGLA9696D	5132	5.5	96	96	42.86	29.3

EVPRGLA • Acoustic Grid - 144" wide

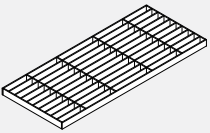

Configuration: 24"- 30"- 36"- 30"- 24"

- PET felt Acoustic Grid to be installed on top of Evolve panels.
- Acoustic Grid kit includes felt pieces, aluminum channel and all necessary hardware.
- PET felt slats run from side to side.
- PET felt pieces available in standard PET felt colours.
- Top trim with channel and beam above opening to be ordered separately.
- Shipped KD.
- For a different felt color for the outer PET frame, choose the code with a D at the end.

PRODUCT CODE	PRICE	SIZE/INCHES			WEIGHT LBS	VOL FT ³
		H	W	D		
EVPRGLA120144	7655	6	144	120	73.86	55.0
EVPRGLA120144D	7655	6	144	120	73.86	55.0

STEP BY STEP SPECIFICATION • 8 WIRE ELECTRICAL SYSTEM

Step 1 Determine the location of the power source entering the panel run.

1. At the base of the panel.
 - a) Use EVE8FR Reversible Floor Power Entry (default to EVE8FR).
 - b) Select the panel to which the Floor Power Entry will be attached. This panel requires an EVE8PD Power Distribution Housing.
 - c) Select the side of the panel and the receptacle outlet to which the Floor Power Entry is to be attached.
2. From the ceiling.
 - a) Use EVE8EC1 Ceiling Power Entry.
 - b) Select the post through which to feed the Ceiling Power Entry.
 - c) One panel adjacent to the selected post requires an EVE8PD Power Distribution Housing.
 - d) Attach Ceiling Power entry to the nearest end of the Power Distribution Housing.

Step 2 Determine which panels are to be powered.

1. Use EVE8PD Power Distribution Housing that corresponds with the width of the panel.

Step 3 Connect power to the powered panels.

1. Use EVE8CP16 Jumper Cable between two adjacent powered panels.
2. Use EVE8CP20 Jumper Cable between two adjacent powered panels separated by a post.

3. Use EVE8CP Pass-Through Cables to connect powered panels that are separated by one or more non-powered panels (maximum distance between the powered panels is 12 feet).
 - a) The length of the Pass-Through Cable is calculated by adding together the widths of the non-powered panels that separate the two powered panels and applying an additional 16" to the total. (EVE8PD Power Distribution Housing is positioned 8" in from the ends of the powered panel.)
 - b) An additional 4" must be added to the Pass-Through Cable for each post that the cable passes through.
4. From the price list, select the EVE8CP Pass-Through Cable that matches the calculated length. If the length is between listed sizes, use the next size up.

Step 4 Determine the location and circuitry of the receptacles.

1. Each powered panel has four (4) potential locations for EVE8RD Duplex Receptacles – 2 per side. (Exception: 24" wide panel has only two potential locations – 1 per side, 18" wide panel has no locations for receptacles.)
2. At each receptacle location there is a choice of four (4) circuit options. Select a circuit option for each location. Circuits one and two are utility circuits; circuits A and B are dedicated circuits.

DEFINITION OF COMPONENTS**Power Distribution Housing**

Power Distribution Housing must be specified for each panel where power is required. Order a power kit for the panel width requiring power. The kit is field installed.

Jumper Cable

A Jumper Cable must be ordered to connect two powered panels. The EVE8CP16 connects two powered panels. The EVE8CP20 connects two powered panels with a 90° connector post between the panels (two-way, three-way, four-way configurations).

A Pass-Through Cable

A Pass-Through Cable allows cables to be passed from a powered panel through one or more non-powered panels (panels that do not require electrical outlets) to connect to another powered panel. (See Step-by-Step Specification for details.)

Duplex Receptacles

Duplex Receptacles snap into place in the power housing. Four circuits may be specified. Circuits A and B are dedicated. Up to two duplexes per side may be installed in a power way for panels 30" and wider. 24" panels will accept one Duplex Receptacle per side. 18" panels will not accept Duplex Receptacles.

Power Entry

To power an Evolve panel, order either a floor power entry or a ceiling power entry. A floor power entry module will take the place of a duplex receptacle by snapping into the base power way.

Desktop Data/Power Receptacle

This module is positioned in the scoop of an Evolve worksurface and provides two simplex plugs and two voice/data ports or two simplex plugs only and two voice data only. A 6 foot power cord can be plugged into a powered Evolve raceway.

WIRE SCHEMATIC

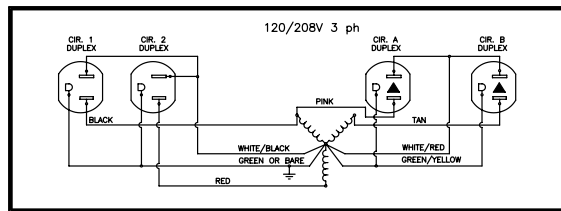
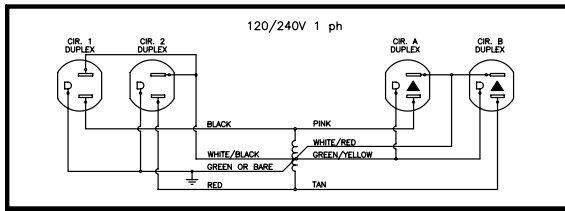

4-2-2 Wiring Schematic
 8-Wire Shared Neutral
 "2+2" - 2 Utility circuits, 2 dedicated

8 Wires
 4 Lines (12 ga.)
 2 Neutrals (10 ga.)
 2 Grounds (12 ga.)

4 Circuits
 2 Utility Circuits
 2 Dedicated Circuits

Receptacles
 Duplex - Up to 6 receptacles per circuit (Up to 48 infeed)

Specifications
 System rated for connection to a grounded 120/240 V, single phase, 20A, 60Hz or 120/208 V, 3 phase, 20A, 60Hz branch circuit for U.S. and 15A if product is marked with a C-UL Mark. Outlets rated 15A max.

UL RECOGNIZED AND CSA CERTIFIED

Warning: It is recommended that installation of the electrical harness be made under the supervision of a licensed electrician in accordance with applicable codes and regulations.

Special Note: Always determine that harness is electrically connected to only one power supply.

COMPONENTS REQUIRED

- a) EVE8PD42 • Power Distribution Housing
Note: 8 wire, 4 circuits (A and B circuits access dedicated circuits).
- b) EVE8CP16 • Jumper Cable
Note: EVE8CP16 connects two powered panels positioned side by side. EVE8CP20 connects two powered panels separated by a post.
- c) EVE8RD • Duplex Receptacle
Note: 1 and 2 access utility circuits.
- d) EVE8CP • Pass-Through Cable
Note: An "I" connector is available to connect 2 Pass-Through Cables.

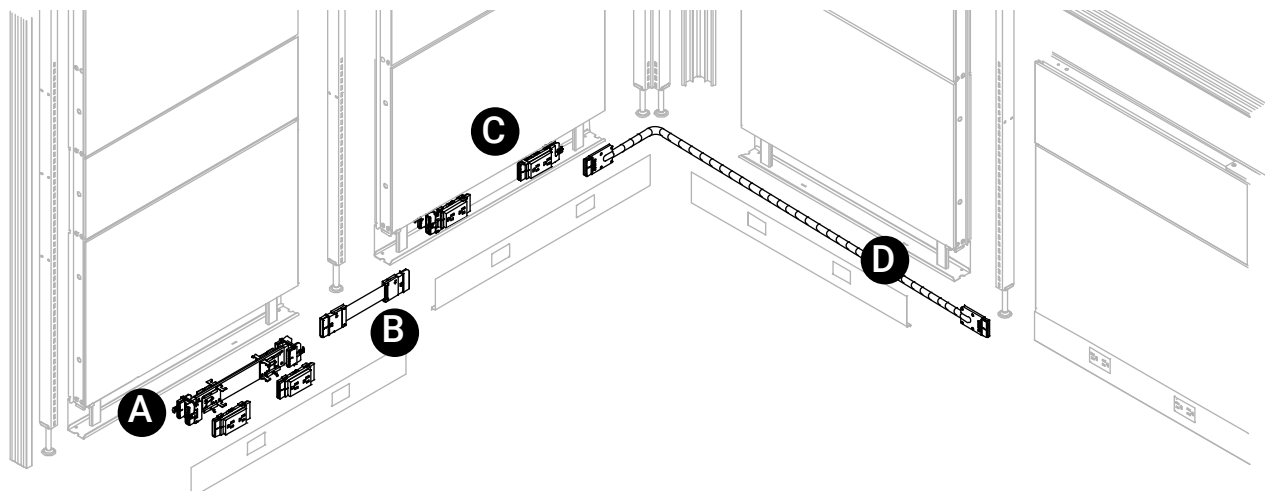

EVE8CI-1 • “I” Connector

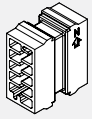

- Female - Female connector used to connect two Pass-Through Cables.

PRODUCT CODE	PRICE	SIZE/ INCHES			WEIGHT VOL	
		H	W	D	LBS	FT ³
EVE8CI-1	85	15	15	0.75	0.06	0.20

EVE8RD • Duplex Receptacles

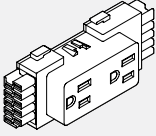

- Up to 6 duplex receptacles per circuit.
- EVE8RD1 = Circuit #1 (utility circuit)
- EVE8RD2 = Circuit #2 (utility circuit)
- EVE8RDA = Circuit #A (dedicated)
- EVE8RDB = Circuit #B (dedicated)

PRODUCT CODE	PRICE	SIZE/ INCHES			WEIGHT VOL	
		H	W	D	LBS	FT ³
EVE8RD1	35	2	4.625	1.25	0.16	0.01
EVE8RD2	35	2	4.625	1.25	0.16	0.01
EVE8RDA	35	2	4.625	1.25	0.16	0.01
EVE8RDB	35	2	4.625	1.25	0.16	0.01

EVEUSB01 • Duplex Receptacles

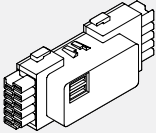

- The USB charging module provides convenient charging power access through dual ports on face of the receptacle.
- Two USB ports.
- 2 Amp output via two USB ports, considered as circuit #1.
- Available in white, black.

PRODUCT CODE	PRICE	SIZE/ INCHES			WEIGHT VOL	
		H	W	D	LBS	FT ³
EVEUSB01WHT	238	2	4.625	1.25	0.16	0.01
EVEUSB01BLK	238	2	4.625	1.25	0.16	0.01

EVE8RDx-20 • Duplex Receptacles, 20AMP

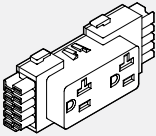

- Up to 6 receptacles per circuit (24 per infeed) not to exceed total 20 Amps per circuit.
- EVE8RD1 = Circuit #1 (utility circuit)
- EVE8RD2 = Circuit #2 (utility circuit)
- EVE8RDA = Circuit #A (dedicated)
- EVE8RDB = Circuit #B (dedicated)

PRODUCT CODE	PRICE	SIZE/ INCHES			WEIGHT VOL	
		H	W	D	LBS	FT ³
EVE8RD1-20	40	2	4.625	1.25	0.16	0.01
EVE8RD2-20	40	2	4.625	1 1/4	0.16	0.01
EVE8RDA-20	40	2	4.625	1 1/4	0.16	0.01
EVE8RDB-20	40	2	4.625	1 1/4	0.16	0.01

EVE8FR1 • Reversible Floor Power Entry

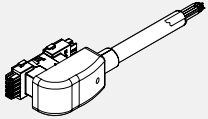

- Takes the place of a duplex receptacle by snapping into the base power way.
- Includes 72" long liquid-tight conduit.
- Must be hard wired to source power by a licenced electrician.

PRODUCT CODE	PRICE	SIZE/ INCHES	WEIGHT VOL	
			L	LBS
EVE8FR1	353	72	3.82	2.00

EVE8FR2 • Reversible Floor Power Entry

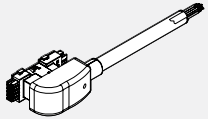

- Takes the place of a duplex receptacle by snapping into the base power way.
- Includes 144" long liquid-tight conduit.
- Must be hard wired to source power by a licenced electrician.

PRODUCT CODE	PRICE	SIZE/ INCHES	WEIGHT VOL	
			L	LBS
EVE8FR2	454	144	6.98	2.00

EVE8FP • Floor Power Supply

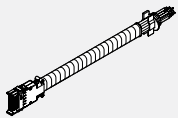

- Snaps in end of power distribution housing
- Includes flexible vinyl conduit
- Must be hard wired to source by licenced electrician
- Diameter is 0,85"

PRODUCT CODE	PRICE	SIZE/ INCHES	WEIGHT VOL	
			L	LBS
EVE8F1P	353	72	3.82	2
EVE8F2P	454	144	6.98	2

EVE8PD • Power Distribution Housing

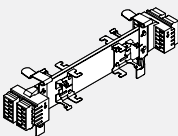

- Power housing is specified per panel size. eg. EVE8PD36 is for use with a 36" panel.
- 8 wire, 4 circuits (A and B circuits are dedicated).
- Provides two duplex receptacles per panel side on all panel widths above the 24" wide panel.
- 24" wide panel allows for only one (1) duplex receptacle per panel side.

PRODUCT CODE	PRICE	SIZE/ INCHES	WEIGHT VOL	
			W	LBS
EVE8PD24	156	9.25	0.83	1.17
EVE8PD30	208	15.25	1.28	1.17
EVE8PD36	220	21.25	1.62	1.65
EVE8PD42	226	27.25	2.00	2.00
EVE8PD48	238	33.25	0.18	0.16
EVE8PD54	242	39.25	2.66	3.20
EVE8PD60	243	45.25	3.04	3.20
EVE8PD66	253	51.25	3.49	3.25
EVE8PD72	262	57.20	3.76	3.30

EVE8CT • Transition Cable

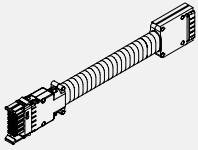

- The EVE8CT16 electrically connects an EVEPD Power Distribution Housing (pre-April 1, 2005) to an EVE8PD Power Distribution Housing when connecting powered panels that are positioned side by side.
- The EVE8CT20 electrically connects an EVEPD Power Distribution Housing (pre-April 1, 2005) to an EVE8PD Power Distribution Housing when connecting powered panels that are separated by a post.
- If there is one or more pass-through panels that contain the old Power Distribution Housing (pre-April 1, 2005) and a panel that contains the new Power Distribution Housing, then an EVE9CI-1 "I" Connector can be attached to the Transition Jumper Cable. This allows for the addition of an appropriate EVE8CP Pass-Through Cable to span the gap between the EVE8CT Transition Cable and the EVE8PD Power Distribution Housing.

PRODUCT CODE	PRICE	SIZE/ INCHES	WEIGHT LBS	VOL FT ³
EVE8CT16	128	16	0.78	1.17
EVE8CT20	147	20	0.92	1.17

EVE8CP • Jumper Cable

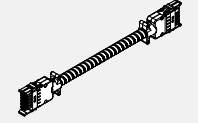

- The EVE8CP16 electrically connects two powered panels positioned side by side.
- The EVE8CP20 electrically connects two powered panels separated by a post.

PRODUCT CODE	PRICE	SIZE/ INCHES	WEIGHT LBS	VOL FT ³
EVE8CP16	128	16	0.66	1.17
EVE8CP20	147	20	0.78	1.17

EVE8CP-H • Hybrid Pass Through Cables with Wire Mesh

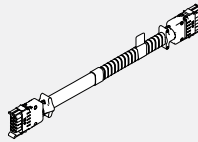

- Flexible metal conduit with wire mesh distributes electrical power through non powered panels.
- To calculate the length of Hybrid Pass Through Cable, add the width of non powered panels separating the powered panels. To this add 16" (distance from edge of the panels to power distribution housing x2).
- Please add an additional 3" when passing through a post. Please see the the beginning of this section.
- Hybrid Pass Through Cables with wire mesh allows connection at 90 degree post and one end for Power Beam.

PRODUCT CODE	PRICE	SIZE/INCHES			WEIGHT LBS	VOL FT ³
		H	W	D		
EVE8CP40-H	196		40		1.44	1.17
EVE8CP46-H	204		46		1.71	1.17
EVE8CP52-H	212		52		1.95	1.17
EVE8CP58-H	226		58		2.21	1.17
EVE8CP64-H	235		64		2.37	1.17
EVE8CP70-H	240		70		2.60	1.17
EVE8CP76-H	244		76		2.81	1.17
EVE8CP82-H	255		82		3.03	1.17
EVE8CP88-H	264		88		3.05	1.17
EVE8CP94-H	273		94		3.42	1.17
EVE8CP100-H	281		100		3.47	1.17
EVE8CP106-H	292		106		3.87	1.17
EVE8CP118-H	309		118		4.08	1.17
EVE8CP130-H	337		130		4.73	1.17
EVE8CP142-H	351		142		4.89	1.17

EVE8CP • Pass Through Cable

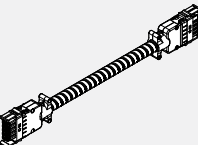

- Flexible metal conduit is used to distribute electrical power through non-powered panels.
- To calculate the length of a Pass-Through Cable, add the widths of the non-powered panels separating the powered panels (panels with distribution housing attached). To this, add 16" (distance from the edge of the panel to the distribution housing x 2). See Technical Information page at the beginning of this section.

PRODUCT CODE	PRICE	SIZE/ INCHES	WEIGHT LBS	VOL FT ³
EVE8CP40	164	40	1.44	1.17
EVE8CP46	169	46	1.71	1.17
EVE8CP52	177	52	1.95	1.17
EVE8CP58	188	58	2.21	1.17
EVE8CP64	196	64	2.37	1.17
EVE8CP70	200	70	2.60	1.17
EVE8CP76	204	76	2.81	1.17
EVE8CP82	213	82	3.03	1.17
EVE8CP88	220	88	3.05	1.17
EVE8CP94	228	94	3.92	1.17
EVE8CP100	233	100	3.47	1.17
EVE8CP106	243	106	3.87	1.17
EVE8CP118	257	118	4.08	1.17
EVE8CP130	281	185	4.73	1.17
EVE8CP142	293	142	4.59	1.17

EVE8CP18 • Flexible Mesh Jumper Cable

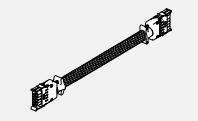

- Electrically connects two powered panels separated by post.
- Used to connect two power distribution housing in Power Beam at 90 degrees.

PRODUCT CODE	PRICE	SIZE/INCHES			WEIGHT LBS	VOL FT ³
		H	W	D		
EVE8CP18	147		18.5		0.78	1.17

EVH8RC • Raceway Covers

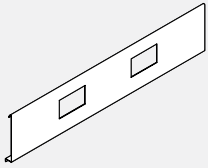

- Raceway Covers with 1.35 x 2.68" duplex receptacle openings.
- Includes 2 receptacle opening shields.
- Raceway Covers are sold individually.
- Used when adding to existing panel installation ordered prior to April 1, 2005.

PRODUCT CODE	PRICE	SIZE/ INCHES		WEIGHT VOL	
		H	W	LBS	FT ³
EVH8RC24	30	6	24	1.00	0.11
EVH8RC30	37	6	30	1.10	0.12
EVH8RC36	41	6	36	1.20	0.13
EVH8RC42	48	6	42	1.30	0.14
EVH8RC48	58	6	48	1.40	0.15
EVH8RC54	66	6	54	1.40	0.15
EVH8RC60	68	6	60	1.50	0.16

EVH8RA • Raceway Opening Adapter

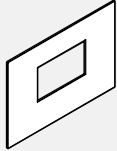

- Used when using new electrical and adding to existing panel installation ordered prior to April 1, 2005.
- PVC Adapter reduces the size of the Duplex Receptacle opening to accommodate the new style Duplex Receptacles.
- Pressure fits inside existing (old style) Raceway Cover.
- Opening size is 1.35" x 2.68".
- Sold in packs of 12, black only.

PRODUCT CODE	PRICE	SIZE/ INCHES		WEIGHT VOL	
		W	L	LBS	FT ³
EVH8RA01	93	16	16	0.01	0.01

EVE8EC • Ceiling Power Entry

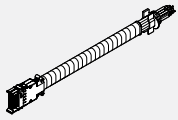

- Snaps into the end of Power Distribution Housing.
- Flexible metal conduit extends into the ceiling through a corner post and post extension (both ordered separately).
- Must be hard wired to source power by a licensed electrician.
- 4" Junction Box included.

PRODUCT CODE	PRICE	SIZE/ L	INCHES		WEIGHT VOL	
			L	LBS	FT ³	
EVE8EC1	268	132	5.24	2.00		
EVE8EC2	479	144	5.96	2.00		

EVDPE • Post Extension Data/Comm Lay-in

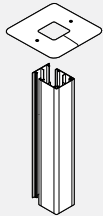

- Attaches to the top of a post to bring power and/or data cables from the ceiling to panel power way.
- Three-sided power pole with snap-on fourth side.
- Post extension can be opened on one side for lay-in for power and/or data cables.
- Made of aluminum and can be field cut.
- Accommodates up to 25 CAT5 cables with electric. Accommodates up to 45 CAT5 cables without electric.
- Ceiling infeed installed on one way post with T Leg requires securing post with two Floor mount plates.
- Post extension bigger than 82" is made of two parts.

PRODUCT CODE	PRICE	SIZE/ H	INCHES		WEIGHT VOL	
			W	LBS	FT ³	
EVDPE64	160	64	2.875	3.00	0.70	
EVDPE82	197	82	2.875	4.20	0.80	
EVDPE88	302	88	2.875	4.50	0.85	
EVDPE94	323	94	2.875	4.80	0.92	
EVDPE100	344	100	2.875	5.12	0.97	

EVDP4E • 45° Post Extension Data/Comm Lay-in



- Attached to the top of the 45° Corner Post to bring power and/or data cables from the ceiling to the panel run through.
- Cable Capacity
 - 40 CAT5 cables without electric feed.
 - 10 CAT5 cables with electric feed.

PRODUCT CODE	PRICE	SIZE/ H	INCHES		WEIGHT VOL	
			W	LBS	FT ³	
EVDP4E64	162	64	3.65	3.00	0.70	
EVDP4E82	218	82	3.65	4.20	0.80	

EVDP6E • 60° Post Extension Data/Comm Lay-in



- Attached to the top of the 60° Corner Post to bring power and/or data cables from the ceiling to the panel run through.
- Post extension can be opened on one side for lay-in power and/or data cables.
- Made of aluminum and can be field cut.
- Two sided power pole with snap-on third side.
- Cable Capacity
 - 32 CAT5 cables without electric.
 - 15 CAT5 cables with electric

PRODUCT CODE	PRICE	SIZE/ H	INCHES		WEIGHT VOL	
			W	LBS	FT ³	
EVDP6E64	157	64	2	3.00	0.70	
EVDP6E82	192	82	2	4.20	0.80	

EVEJBC1 • Hardwire Junction Box

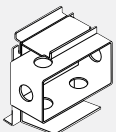

- Provides economical single circuit capability.
- Can be used in addition to 8 wire system to support isolated hospital power.
- Can be retrofitted in any size of panel at the receptacle location.
- Gives access from one side only at each location.
- Customer to supply conduit, wiring, receptacle, and face plate.
- A licensed electrician must provide hardwire connection with the junction box.

PRODUCT CODE	PRICE	WEIGHT VOL	
		LBS	FT ³
EVEJBC1	105	1.50	0.02

Power Beam

- All metal components are painted with environmentally friendly epoxy powder.
- Raceway interiors are coated with recycled epoxy powder.
- The entire Evolve Power Beam and the processes used to manufacture it are designed to save and protect the environment. Evolve panels are made from recycled materials and are 100% recyclable.
- Components conform to CGSB and ANSI/BIFMA Standards.
- The quality and performance level of these panels have been tested to equal or exceed the requirements of the U.S. Government.
- Power Beam has a steel frame and is 2 7/8" thick. Corner posts create a panel creep of 3 1/4".
- Leveling glides extend 1 1/2" high.

Power Beam Options

- Power Beams are available in the following heights: 24", 30", and 36".
- Module widths come in seven (7) sizes: 36", 42", 48", 54", 60", 66" and 72".
- Straight, 90 degree & 120 degree.

Extension Module Options

- Acoustic Fabric (Tackable), Glazed, Open, Laminate, Whiteboard, Air Flow.
- Attaches to the top of the Power Beam or another extension module (not to exceed 42" above finished floor).
- Offered in 6", 12", and 18" heights.
- Can be stacked up to 42" high above the finished floor (A.F.F.).

Beam Reconfiguration

- Extension Modules can be modified on site by replacing fabric modules with Glazed, Open, Laminate, Whiteboard or Air Flow at any time after the initial installation.
- Fabric can be replaced easily; using pre-cut segments of fabric, a drawstring (C-Jex) is sewn in around the edges. Then a rubber spline is used to 'screen' the fabric in place.

Voice/Data And Electrical Power

- NOTE: Panels and Electric components are CSA/UL approved. Tools are not required to install electrical in the Power Beam.

Electric Information

- Electric can be run in all three Power Beam heights (24" h, 30" h or 36" h).
 - 8-Wire, 4 circuit capability
 - 2 utility + 2 dedicated circuits
 - 10 gauge (oversized) neutrals
- All circuits can support up to 15 a max.
- Contact Evolve customer care for additional wiring options.

Raceway Information

- Raceway knockouts sizes conform to the ANSI/TIA/ EIA Furniture Opening Standard of 1.38" x 2.71".
- Power Beam raceway covers 36"-60" wide accommodate knockouts for two electrical duplexes and one communication face plate on each side. 66" wide beam accommodates 4 electrical duplexes and one communication face plate on each side. 72" wide beam accommodates 4 duplex receptacles and 2 communication face plates on each side.
- Standard data face mount plates can be used without the need of adapter plates (supplied by others).
- Cabling capacities (calculations below are based on .25" diameter communication cables.)
- Power Modules:
 - Without electric – 65 Cables
 - With electric – 54 Cables
- Panel Connectors - 90 Degree Connector Posts:
 - Without electric – 45 cables
 - With electric – 25 Cables

Work Tables

- Freestanding tables
 - Foli height adjustable (23" or 29"d)
 - Bungee (20", 24" or 30"d)
 - Junction (20", 24" or 30"d)
 - 2gether (18" or 24"d)

Power Beam is a freestanding beam system and does not support attachment of an Evolve brackets or overhead storage including cantilevers or other support brackets.

Features, Benefits & General Information

Technical Features of Power Beam:

- Evolve Power Beam is 2 7/8" thick.
- An aluminum low profile top cap is included with Power Beams.
- Power Beam will accommodate 65 x 0.25" diameter communication cables without electrical or 54 x 0.25" diameter communication cables with electrical.
- 90-degree post extension accommodates 45 x 0.25" diameter communication cables without electrical and 25 x 0.25" diameter communication cables with electric.
- Raceway knockout openings are 1.38" x 2.71".

Basic Features of Power Beam

- Power Beam is available in three (3) heights: 24" h, 30" h and 36" h; and seven (7) widths: 36" w, 42" w, 48" w, 54" w, 60" w, 66" w and 72" w.
- There is no panel creep in a straight Beam-to-Beam configuration; however, a corner post (2, 3, 4 way) will add 3.25" inches to a beam run.

Basic Features of Extension Modules

- Extension modules stack on the top of a Power Beam or another extension module (maximum height - 42" h, above finished floor).
- Fabric extension modules may have different fabrics on opposite sides within the same grade with no up-charge.
- If different grades of fabric are used on one module, the entire modules will be priced utilizing the fabric with the highest grade.

Power Beam Parts

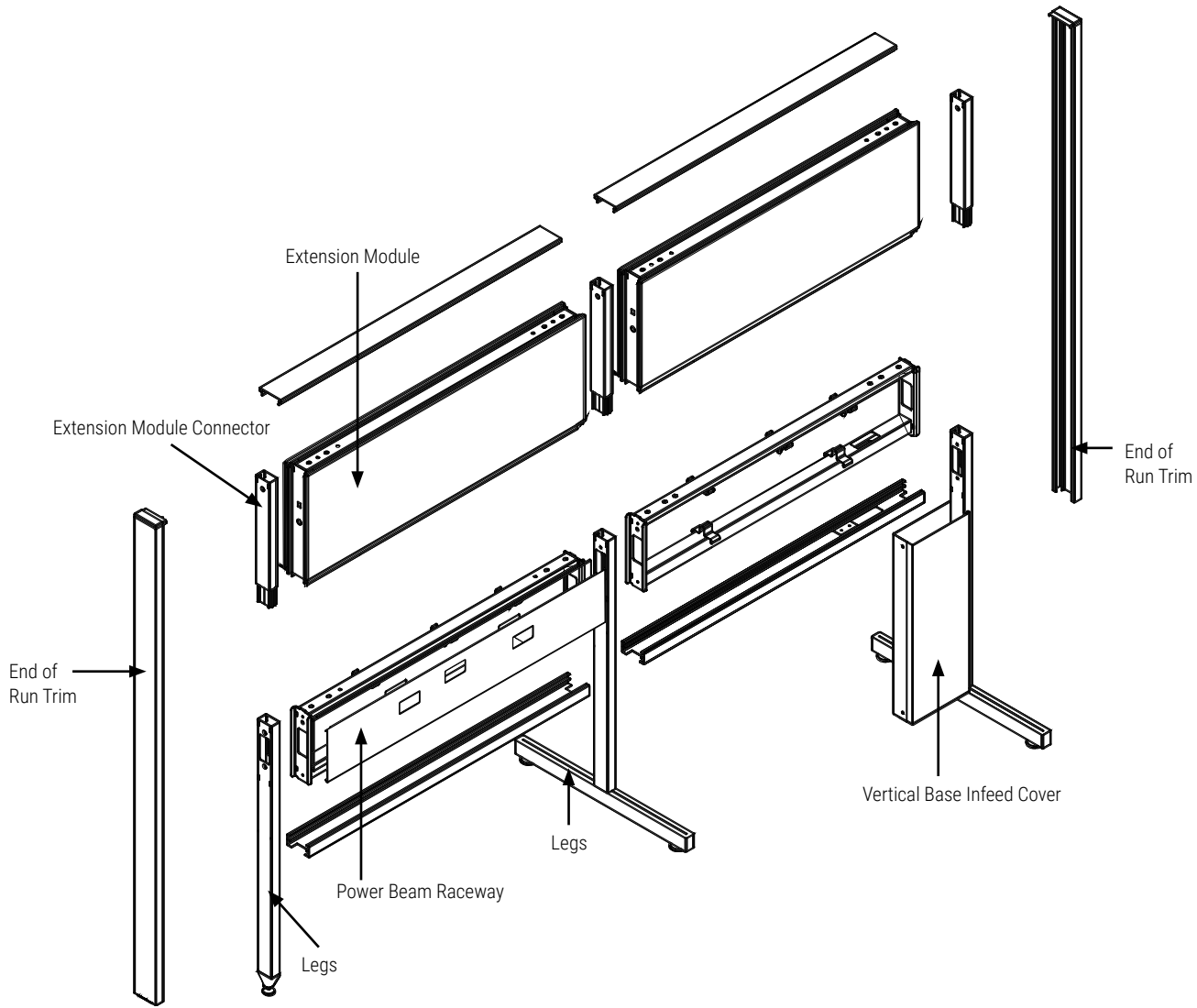

Extension Module Materials

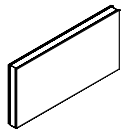

Fabric

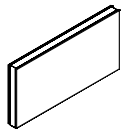

Laminate

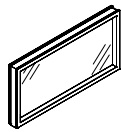

Glass



Write Board

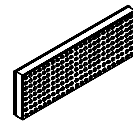

Airflow

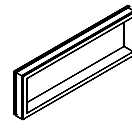

Open

EVPB • Power Beam

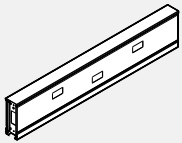

- Aluminum top trim and bottom trim included
- No access for base infeed
- Support legs ordered separately

PRODUCT CODE	PRICE	SIZE/ INCHES			WEIGHT VOL	
		H	W	D	LBS	FT ³
EVPB36	215	6	36	2.875	15.5	0.48
EVPB42	237	6	42	2.875	17.1	0.56
EVPB48	256	6	48	2.875	18.6	0.64
EVPB54	281	6	54	2.875	20.2	0.72
EVPB60	306	6	60	2.875	21.8	0.80

EVPB • 6" High Power Beam

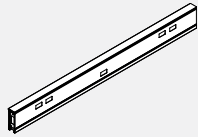

- One piece aluminum top trim and one piece aluminum bottom trim included.

PRODUCT CODE	PRICE	SIZE/ INCHES			WEIGHT VOL	
		H	W	D	LBS	FT ³
EVPB66	479	6	66	2.875	31	0.91
EVPB72	495	6	72	2.875	32	1.00

EVPBE • Power Beam with Electrical Cut-out for Base Feed

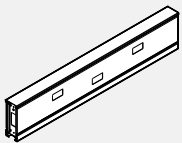

- Power beam with bottom cut out (on one end) for base infeed
- Aluminum top and bottom trims included
- Bottom trim has a cut out on one side for electrical access and a bracket to connect to the vertical base infeed cover (ordered separately)
- Vertical base infeed cover with support leg ordered separately

PRODUCT CODE	PRICE	SIZE/ INCHES			WEIGHT VOL	
		H	W	D	LBS	FT ³
EVPBE36	227	6	36	2.875	15.5	0.48
EVPBE42	252	6	42	2.875	17.1	0.56
EVPBE48	276	6	48	2.875	18.6	0.64
EVPBE54	297	6	54	2.875	20.2	0.72
EVPBE60	325	6	60	2.875	21.8	0.80

EVPBE • Power Beam Kit with Electrical Cut-out for Base Feed

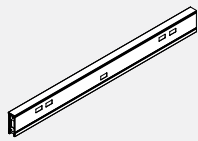

- 66" Power Beam Kit consists of (1) 30" Power Beam and (1) 36" Power Beam with bottom cut out on one side for a base infeed. Inline connector and hardware included.
- Vertical base infeed cover with support leg ordered separately.

PRODUCT CODE	PRICE	SIZE/ INCHES			WEIGHT VOL	
		H	W	D	LBS	FT ³
EVPBE66	507	6	66	2.875	31	0.91
EVPBE72	524	6	72	2.875	32	1.00

EVPBEP-KIT • Power Beam with Electrical Cut-out for Pass Through Cabinet

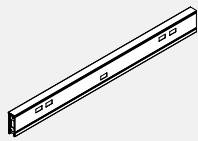

- Power beam with electrical cutout for base feed from pass through cabinet.
- Aluminum top trim included.
- 60" Power beam kit includes two 30" power distribution housing (EVE8PD30) and jumper cable (EVE8CP17).
- 72" Power beam kit includes two 36" power distribution housing (EVE8PD36) and jumper cable (EVE8CP17).
- Provides two duplex receptacle per panel side.
- Power beam base feed to be ordered separately.
- Power beam storage cabinet with pass through be ordered separately (EVPBSCGDP or EVPBSCP).
- Note: To be used with cable pass through cabinet EVPBSSCGDPR/L.

PRODUCT CODE	PRICE	SIZE/ INCHES			WEIGHT VOL	
		H	W	D	LBS	FT ³
EVPBEP60KIT	789	6	60	2.875	23.4	0.86
EVPBEP72KIT	1000	6	72	2.875	25.1	0.96

EVPBEP-KIT01 • Power Beam with Electrical Cut-out for Pass Through Cabinet with Two Raceway Covers per Side

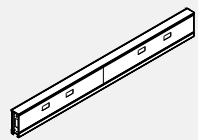

- Power beam with electrical cut out for base feed from pass through cabinet.
- Aluminum top trim included.
- 60" Power beam kit includes two 30" raceway covers per side.
- 72" Power beam kit includes two 36" raceway covers per side.
- 60" Power beam kit includes two 30" power distribution housing (EVE8PD30) and jumper cable (EVE8CP17).
- 72" Power beam kit includes two 36" power distribution housing (EVE8PD36) and jumper cable (EVE8CP17).
- Provides four duplex receptacle per panel side.
- Power beam base feed to be ordered separately.
- Power beam storage cabinet with pass through be ordered separately (EVPBSCGDP or EVPBSCP).
- Note: To be used with cable pass through cabinet EVPBSSCGDPR/L.

PRODUCT CODE	PRICE	SIZE/ INCHES			WEIGHT VOL	
		H	W	D	LBS	FT ³
EVPBEP60KIT01	789	6	60	2.875	23.4	0.88
EVPBEP72KIT01	1000	6	72	2.875	25.1	0.96

EVPBFCL • Vertical Base Power Feed Cover with Leg

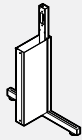

- Connects to Power Beam Kit with electrical cut out.
- Includes vertical cover and slotted connector support leg with foot.
- Power Beam kit with electrical cut out ordered separately.
- Base infeed ordered separately.

PRODUCT CODE	PRICE	SIZE/ INCHES			WEIGHT VOL	
		H	W	D	LBS	FT ³
EVPBFCL24	195	24	6	21	10.1	1.75
EVPBFCL30	218	30	6	21	11.2	2.18
EVPBFCL36	240	36	6	21	12.3	2.62

EVPBFCSL • Base Power Feed Cover with Single Leg

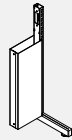

- Connects to Power Beam Kit with electrical cut out
- Includes vertical cover and slotted connector support with single leg.
- For one sided Power beam application.
- Laminate end panels must be attached to single leg at the end of power beam run for stability.
- Laminate end panels to be ordered separately.
- End of run trim below power beam included.
- Power beam with electrical cut out to be ordered separately.
- Note: Cannot be used with Power Beam storage or Power Beam overhead.

PRODUCT CODE	PRICE	SIZE/ INCHES			WEIGHT VOL	
		H	W	D	LBS	FT ³
EVPBFCSL24	186	24	6	21	10.10	1.75
EVPBFCSL30	208	30	6	21	11.20	2.18
EVPBFCSL36	228	36	6	21	12.30	2.62

EVPBFCLS • Vertical Base Power Feed Cover with Slotted Leg

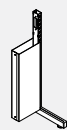

- Slotted connector allows for the attachment of brackets for worksurfaces.
- Connects two Power Beams on equal height.
- Includes vertical covers, slotted connector with leg and end of run trim below the Power Beam.
- Note: Power Beam must be installed in stable configuration using two way posts, three way posts or four way posts to provide support for worksurfaces.

PRODUCT CODE	PRICE	SIZE/ INCHES			WEIGHT VOL	
		H	W	D	LBS	FT ³
EVPBFCLS24	186	24	6	21	10.10	1.75
EVPBFCLS30	208	30	6	21	11.20	2.18
EVPBFCLS36	228	36	6	21	12.30	2.62

EVPBFCG • Vertical Base Power Feed Cover with Glide

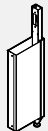

- Connects to Power Beam Kit with electrical cut out
- Includes vertical cover and slotted connector support leg with glide.
- Power Beam Kit with electrical cut out ordered separately.
- Base infeed ordered separately.

PRODUCT CODE	PRICE	SIZE/ INCHES			WEIGHT VOL	
		H	W	D	LBS	FT ³
EVPBFCG24	162	24	6	3	7.1	0.25
EVPBFCG30	183	30	6	3	8.4	0.31
EVPBFCG36	205	36	6	3	9.7	0.38

EVPBFCGS • Vertical Base Power Feed Cover with Glide and Slotted Connector

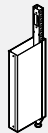

- Slotted connector allows for the attachment of brackets for worksurfaces.
- Connects two Power Beams on equal height.
- Includes vertical covers, slotted connector with glide base and end of run trim below Power Beam.
- Power Beam with electrical cut out to be ordered separately.
- Note: Power Beam must be installed in stable configuration using two way posts, three way posts or four way posts to provide support for worksurfaces.

PRODUCT CODE	PRICE	SIZE/ INCHES			WEIGHT VOL	
		H	W	D	LBS	FT ³
EVPBFCGS24	154	24	6	3	7.10	0.25
EVPBFCGS30	173	30	6	3	8.40	0.31
EVPBFCGS36	194	36	6	3	9.70	0.38

EVPBFCGS • Vertical Base Power Feed Cover with Glide



- 42" H Slotted connector allows to attached brackets for worksurfaces
- Connects to electrical cut out power beam
- Includes vertical covers and slotted connector with glide base
- End of run trim below power beam included
- Power beam with electrical cut out to be ordered separately
- Note: Power beam to be installed in stable configuration using two way posts, three way posts, four way posts to provide support for worksurfaces

PRODUCT CODE	PRICE	SIZE/ INCHES			WEIGHT VOL	
		H	W	D	LBS	FT ³
EVPB24FCGS42	190	42	6	3	10.40	0.43
EVPB30FCGS42	204	42	6	3	10.40	0.43
EVPB36FCGS42	224	42	6	3	10.40	0.43

EVPBGFC • Power Beam Gallery Base Feed Cover



- Connects to electrical cut out power beam attached to gallery panels.
- Includes vertical covers and slotted connector attaches to gallery panel.
- Power beam with electrical cut out to be ordered separately.

PRODUCT CODE	PRICE	SIZE/ INCHES			WEIGHT VOL	
		H	W	D	LBS	FT ³
EVPBGFC24	156	24	6	3	7.1	0.25
EVPBGFC30	177	30	6	3	8.40	0.31
EVPBGFC36	195	36	6	3	9.70	0.38

EVPBGDP • Power Beam Gallery Panel Data Post / Comm Lay-In



- Attaches to Power beam gallery end panel to bring power and/or data cables from ceiling to power beam.
- Three-sided power pole with snap-on fourth side.
- Made of aluminum and can be field cut.
- Standard data post extension used above.
- Accommodates up to 25 CAT 5 cables with electric, up to 45 CAT 5 cables without electric.
- Standard data post extension to be ordered separately.
- Standard code is for 24" H power beam. Please add at code end for option. B- 30" h Power beam. C- 36" h Power beam.

PRODUCT CODE	PRICE	SIZE/ INCHES			WEIGHT VOL	
		H	W	D	LBS	FT ³
EVPBGDP42	149	42	2	2	2.20	0.60
EVPBGDP48	165	48	2	2	3.00	0.70
EVPBGDP54	202	54	2	2	4.20	0.80

EVE8FR3PBD • Double Entry for Power Beam

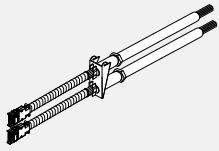

- Each power feed entry snaps into separate power distribution housing.
- Includes two 84" long flexible vinyl conduit.
- Includes double bracket to attach to Verticle base power feed cover leg.
- Must be installed in middle between two power beams, one base feed plugs to powerbeam on opposite side of leg than attached bracket.
- Vertical base power feed cover with leg to be ordered seperately.
- Must be hardwired to source by licenced electrician.
- Note: Always determine that harness is electrically connected to only one power supply.

PRODUCT CODE	PRICE	SIZE/ H	INCHES W	D	WEIGHT LBS	VOL FT ³
EVE8FR3PBD	661		84		7.64	2.00

EVHCBP01 • Ceiling Bracket for Post

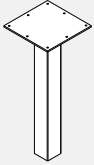

- Used to secure corner post to ceiling.
- 4.8"x4.8" top plate with 1.5x1.5 square tube 12" H , square tube fits inside aluminum corner post.
- Square tube can slide in post, bracket pushed to ceiling to be secured.

PRODUCT CODE	PRICE	SIZE/ H	INCHES W	D	WEIGHT LBS	VOL FT ³
EVHCBP01	60	12	4.8	4.8	3.2	0.18

EVHCBIC01 • Ceiling Bracket for Inline Connector

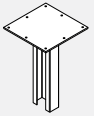

- Used to secure corner post to ceiling .
- 4.8"x4.8" top plate with 7.5" h insert in middle of plate, insert its inside connector.
- 7.5" H insert can slide in connector, bracket pushed to ceiling to secure.
- Note: Care should be taken to attach ceiling brackets to secure ceiling using correct fastners.
- Failure to do so may result in collapse of unit and subsequent possible injury.

PRODUCT CODE	PRICE	SIZE/ H	INCHES W	D	WEIGHT LBS	VOL FT ³
EVHCBIC01	60	7.5	4.8	4.8	3.2	0.18

EVHCBER01 • Ceiling Bracket for End of Run Connector

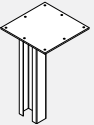

- Used to secure corner post to ceiling.
- 4.8"x4.8" top plate with 7.5" h insert in middle of plate, insert its inside connector.
- 7.5" H insert can slide in connector , bracket pushed to ceiling to secure.
- Note: Care should be taken to attach ceiling brackets to secure ceiling using correct fastners.
- Failure to do so may result in collapse of unit and subsequent possible injury.

PRODUCT CODE	PRICE	SIZE/ H	INCHES W	D	WEIGHT LBS	VOL FT ³
EVHCBIC01	80	7.5	4.8	4.8	3.2	0.18

EVPBL • Power Beam Connector with Leg

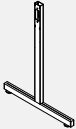

- Connects two Power Beams in a straight run.
- 24" h -- 18" open to floor.
- 30" h -- 24" open to floor.
- 36" h -- 30" open to floor.

PRODUCT CODE	PRICE	SIZE/ H	INCHES W	D	WEIGHT LBS	VOL FT ³
EVPBL24	99	24	18	3	5.9	0.30
EVPBL30	103	30	18	3	7.2	0.38
EVPBL36	110	36	18	3	8.5	0.45

EVPBLS • Power Beam Slotted Connector with Leg

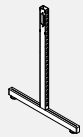

- Slotted connector allows for the attachment of brackets for worksurfaces.
- Connects two Power Beams on equal height.
- Includes slotted connector with leg, glides and connecting hardware.
- Note: Power Beam must be installed in stable configuration using two way posts, three way posts or four way posts to provide support for worksurfaces.

PRODUCT CODE	PRICE	SIZE/ H	INCHES W	D	WEIGHT LBS	VOL FT ³
EVPBLS24	96	24	18	3	5.90	0.30
EVPBLS30	99	30	18	3	7.20	0.38
EVPBLS36	103	36	18	3	8.50	0.45

EVPBLFF • Power Beam Leg with Flat Foot

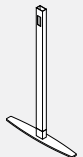

- Connects two power beams on equal height.
- Includes connector with flat foot, connecting hardware
- Note: Leg has to be used next to Post legs with glides.
- When specifying please keep sequence post leg with glide, leg with flat foot, post leg with glide.
- Only post legs with glide provides adjustment for levelling power beams run.

PRODUCT CODE	PRICE	SIZE/ H	INCHES W	D	WEIGHT LBS	VOL FT ³
EVPBLFF24	116	24	21		5.9	0.30
EVPBLFF30	120	30	21		7.2	0.38
EVPBLFF36	125	36	21		8.5	0.45

EVPBSL • Power Beam Single Leg

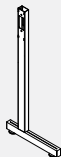

- Connects two Power Beams on equal height.
- Includes non slotted connector with leg, glides and connecting hardware.
- For one sided power beam application.
- Laminate end panels must be attached to single leg at end of power beam run for stability.
- Laminate end panels to be ordered seperately.
- Note: It can not be used with Power Beam storage or Power Beam overhead.

PRODUCT CODE	PRICE	SIZE/ H	INCHES W	D	WEIGHT LBS	VOL FT ³
EVPBSL24	96	24	15	3	5.9	0.21
EVPBSL30	99	30	15	3	7.2	0.26
EVPBSL36	103	36	15	3	8.5	0.32

EVPBGICB • Power Beam Connector with Base for Glide



- Connects two Power Beams in a straight run.
- 24”h -- 18” open to floor.
- 30”h -- 24” open to floor.
- 36”h -- 30” open to floor.

PRODUCT CODE	PRICE	SIZE/ INCHES			WEIGHT VOL	
		H	W	D	LBS	FT ³
EVPBGICB24	67	24	2	3	3.30	0.03
EVPBGICB30	69	30	2	3	4.60	0.04
EVPBGICB36	72	36	2	3	5.90	0.04

EVPBGICBS • Power Beam Slotted Connector with Base for Glide



- Slotted connector allows for the attachment of brackets for worksurfaces.
- Connects two Power Beams of equal heights.
- Includes slotted connector with glide and connecting hardware.
- Note: Power Beam must be installed in stable configuration using two way posts, three way posts or four way posts to provide support for worksurfaces.

PRODUCT CODE	PRICE	SIZE/ INCHES			WEIGHT VOL	
		H	W	D	LBS	FT ³
EVPBGICBS24	63	24	2	3	3.30	0.03
EVPBGICBS30	65	30	2	3	4.60	0.04
EVPBGICBS36	68	36	2	3	5.90	0.04

EVPBGICBS • Power Beam Connector with Base for Glide



- 42” H Slotted connector allows to attached brackets for worksurfaces
- Connects two power beams on equal height and extension panel above
- Includes slotted connector with glide and connecting hardware
- Note: Power beam to be installed in stable configuration using two way posts, three way posts, four way posts to provide support for worksurfaces

PRODUCT CODE	PRICE	SIZE/ INCHES			WEIGHT VOL	
		H	W	D	LBS	FT ³
EVPB24GICBS42	99	42	2	3	6.60	0.16
EVPB30GICBS42	99	42	2	3	6.60	0.16
EVPB36GICBS42	99	42	2	3	6.60	0.16

EVPB24CPA • One Way Post with T Leg for 24” H Power Beam

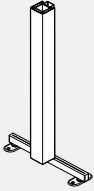

- One way post attaches to end of power beam run.
- Post and connecting hardware add 3.25 to power beam run.
- Includes post power beam T leg, post with trim all round, leveling glide, hardware and trim kit.
- Includes two floor mount plates to secure post to floor.

PRODUCT CODE	PRICE	SIZE/ INCHES			WEIGHT VOL	
		H	W	D	LBS	FT ³
EVPB24CPA124	271	24	3	3	5.5	0.75
EVPB24CPA130	286	30	3	3	8.5	0.94
EVPB24CPA136	298	36	3	3	11.5	1.12
EVPB24CPA142	334	42	3	3	15	1.31

EVPB30CPA • One Way Post with T Leg for 30” H Power Beam

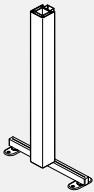

- One way post attaches to end of power beam run.
- Post and connecting hardware add 3.25 to power beam run.
- Includes post power beam T leg, post with trim all round, leveling glide, hardware and trim kit.
- Includes two floor mount plates to secure post to floor.

PRODUCT CODE	PRICE	SIZE/ INCHES			WEIGHT VOL	
		H	W	D	LBS	FT ³
EVPB30CPA130	286	30	3	3	8.5	0.94
EVPB30CPA136	298	36	3	3	11.5	1.12
EVPB30CPA142	334	42	3	3	15	1.31

EVPB36CPA • One Way Post with T Leg for 36” H Power Beam

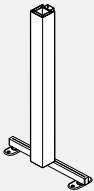

- One way post attaches to end of power beam run.
- Post and connecting hardware add 3.25 to power beam run.
- Includes post power beam T leg, post with trim all round, leveling glide, hardware and trim kit.
- Includes two floor mount plates to secure post to floor.

PRODUCT CODE	PRICE	SIZE/ INCHES			WEIGHT VOL	
		H	W	D	LBS	FT ³
EVPB36CPA136	298	36	3	3	11.5	1.12
EVPB36CPA142	334	42	3	3	15	1.31

EVPBCEPLA4 • Power Beam 4-way Corner Post



- Connects four power beams of equal height in 90 degree configuration.
- Post and connecting hardware add 3.25” to power beam run.
- Includes one post, four nonslotted power beam connectors, post with trim all around, levelling glide, hardware and trim kit.

PRODUCT CODE	PRICE	SIZE/ INCHES			WEIGHT VOL	
		H	W	D	LBS	FT ³
EVPBCEPLA424	188	24	3	3	6.30	0.22
EVPBCEPLA430	210	30	3	3	7.60	0.27
EVPBCEPLA436	205	36	3	3	8.90	0.33

EVPBCEPLA3 • Power Beam 3-way Corner Post



- Connects three power beams of equal height in 90 degree configuration.
- Post and connecting hardware add 3.25" to power beam run.
- Includes one post, three nonslotted power beam connectors, post with trim all around, levelling glide, hardware and trim kit.

PRODUCT CODE	PRICE	SIZE/ INCHES			WEIGHT VOL	
		H	W	D	LBS	FT ³
EVPBCEPLA324	158	24	3	3	5.80	0.22
EVPBCEPLA330	164	30	3	3	7.10	0.27
EVPBCEPLA336	172	36	3	3	8.40	0.33

EVPBCEPLA2 • Power Beam 2-way Corner Post



- Includes one post, four nonslotted power beam connectors, post with trim all around, levelling glide, hardware and trim kit.
- Connects four power beams of equal height in 90 degree configuration.
- Post and connecting hardware add 3.25" to power beam run.

PRODUCT CODE	PRICE	SIZE/ INCHES			WEIGHT VOL	
		H	W	D	LBS	FT ³
EVPBCEPLA224	143	24	3	3	5.30	0.22
EVPBCEPLA230	149	30	3	3	6.60	0.27
EVPBCEPLA236	157	36	3	3	7.90	0.33

EVPBCIPLA2 • Power Beam In Line 2-way Corner Post



- Connects two power beams of equal height in inline configuration.
- Post and connecting hardware add 3.25" to power beam run.
- Includes one post, two nonslotted power beam connectors, post with trim all around, levelling glide, hardware and trim kit.

PRODUCT CODE	PRICE	SIZE/ INCHES			WEIGHT VOL	
		H	W	D	LBS	FT ³
EVPBCIPLA224	143	24	3	3	5.30	0.22
EVPBCIPLA230	149	30	3	3	6.60	0.27
EVPBCIPLA236	157	36	3	3	7.90	0.33

EVPB6CEPLA3 • Power Beam 3-way 120 Degree Corner Post



- Connects three power beams of equal height in 120 degree configuration.
- Includes one post, three nonslotted power beam connectors, post with trim all around, levelling glide, hardware and trim kit.

PRODUCT CODE	PRICE	SIZE/ INCHES			WEIGHT VOL	
		H	W	D	LBS	FT ³
EVPB6CEPLA324	183	24	3	3	5.30	0.22
EVPB6CEPLA330	186	30	3	3	6.60	0.27
EVPB6CEPLA336	195	36	3	3	7.90	0.33

EVPB6CEPLA2 - Power Beam 2-way 120 Degree Corner Post



- Connects three power beams of equal height in 120 degree configuration.
- Includes one post, three nonslotted power beam connectors, post with trim all around, levelling glide, hardware and trim kit.

PRODUCT CODE	PRICE	SIZE/ INCHES			WEIGHT VOL	
		H	W	D	LBS	FT ³
EVPB6CEPLA224	183	24	3	3	5.30	0.22
EVPB6CEPLA230	186	30	3	3	6.60	0.27
EVPB6CEPLA236	195	36	3	3	7.90	0.33

EVPBIEC • Extension Connector for Power Beam



- Attaches to power beam connector.
- Includes non slotted extension connector and connecting hardware.
- Must be attached to power beam connector with provided screw before installing power beam.

PRODUCT CODE	PRICE	SIZE/ INCHES			WEIGHT VOL	
		H	W	D	LBS	FT ³
EVPBIEC06	32	6	2.875	3	1.0	0.06
EVPBIEC12	32	12	2.875	3	2.0	0.12
EVPBIEC18	39	18	2.875	3	3.0	0.18
EVPBIEC24	39	24	2.875	3	4.0	0.24

EVPBIEC • Slotted Extension Connector for Power Beam



- Attaches to Power Beam connector.
- Includes slotted extension connector and connecting hardware.
- Must be attached to Power Beam connector with provided screw before installing Power Beam.

PRODUCT CODE	PRICE	SIZE/ INCHES			WEIGHT VOL	
		H	W	D	LBS	FT ³
EVPBIECS06	32	6	2.875	3	1.00	0.06
EVPBIECS12	32	12	2.875	3	2.00	0.12
EVPBIECS18	39	18	2.875	3	3.00	0.18
EVPBIECS24	39	24	2.875	3	4.00	0.24

EVPBCEP4 • Power Beam Corner Extension Post 4 Way

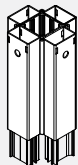

- Connects four extension modules in 90 degree configuration.
- Post and connecting hardware add 3.25" to power beam run.
- Includes one extension post, four non slotted extension connectors for power beam, connecting hardware and trim kit Power Beam.
- Corner Extension Post is not stackable.

PRODUCT CODE	PRICE	SIZE/ INCHES			WEIGHT VOL	
		H	W	D	LBS	FT ³
EVPBCEP406	79	6	3	3	4	0.09
EVPBCEP412	79	12	3	3	8	0.18
EVPBCEP418	125	18	3	3	12	0.27
EVPBCEP424	125	24	3	3	16	0.36

EVPBCEPA3 • Power Beam Corner Extension Post 3 Way

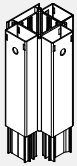

- Connects four extension modules in 90 degree configuration.
- Post and connecting hardware add 3.25" to power beam run.
- Includes one extension post, three non slotted extension connectors for power beam, connecting hardware and trim kit.
- Power Beam Corner Extension Post is not stackable.

PRODUCT CODE	PRICE	SIZE/ INCHES			WEIGHT LBS	VOL FT ³
		H	W	D		
EVPBCEPA306	86	6	3	3	3	0.08
EVPBCEPA312	86	12	3	3	6	0.16
EVPBCEPA318	142	18	3	3	9	0.24
EVPBCEPA324	142	24	3	3	12	0.32

EVPBCEPA2 • Power Beam Corner Extension Post 2 Way

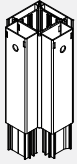

- Connects four extension modules in 90 degree configuration.
- Post and connecting hardware add 3.25" to power beam run.
- Includes one extension post, two non slotted extension connectors for power beam, connecting hardware and trim kit.
- Power Beam Corner Extension Post is not stackable.

PRODUCT CODE	PRICE	SIZE/ INCHES			WEIGHT LBS	VOL FT ³
		H	W	D		
EVPBCEPA206	77	6	3	3	2	0.07
EVPBCEPA212	77	12	3	3	4	0.14
EVPBCEPA218	130	18	3	3	6	0.21
EVPBCEPA224	130	24	3	3	8	0.28

EVPBCEIPA2 • Power Beam In Line Corner Extension Post 2 Way

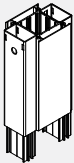

- Connects four extension modules in inline configuration.
- Post and connecting hardware add 3.25" to power beam run.
- Includes one extension post, two non slotted extension connectors for power beam, connecting hardware and trim kit.
- Power Beam Corner Extension Post is not stackable.

PRODUCT CODE	PRICE	SIZE/ INCHES			WEIGHT LBS	VOL FT ³
		H	W	D		
EVPBCEIPA206	96	6	3	3	2	0.07
EVPBCEIPA212	96	12	3	3	4	0.14
EVPBCEIPA218	134	18	3	3	6	0.21
EVPBCEIPA224	134	24	3	3	8	0.28

EVPBCEPA1 • Power Beam Corner Extension Post 1 Way

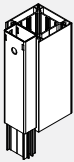

- Connects at end of run of extension modules.
- Post and connecting hardware add 3.25" to power beam run.
- Includes one extension post, one non slotted extension connectors for power beam, connecting hardware and trim kit.
- Power Beam Corner Extension Post is not stackable.

PRODUCT CODE	PRICE	SIZE/ INCHES			WEIGHT LBS	VOL FT ³
		H	W	D		
EVPBCEPA106	70	6	3	3	2	0.07
EVPBCEPA112	70	12	3	3	4	0.14
EVPBCEPA118	97	18	3	3	6	0.21
EVPBCEPA124	97	24	3	3	6	0.21

EVPB6CEP3 • Power Beam 120 Degree Corner Extension Post 3 Way



- Connects three extension modules in 120 degree configuration.
- Includes one extension post, three non slotted extension connectors for power beam, connecting hardware and trim kit.
- Power Beam Corner Extension Post is not stackable.

PRODUCT CODE	PRICE	SIZE/ INCHES			WEIGHT LBS	VOL FT ³
		H	W	D		
EVPB6CEP306	116	6	3	3	3	0.08
EVPB6CEP312	116	12	3	3	6	0.16
EVPB6CEP318	183	18	3	3	9	0.24
EVPB6CEP324	183	24	3	3	12	0.32

EVPB6CEPA2 • Power Beam 120 Degree Corner Extension Post 2 Way



- Connects two extension modules in 120 degree configuration.
- Includes one extension post, two non slotted extension connectors for power beam, connecting hardware and trim kit.
- Power Beam Corner Extension Post is not stackable.

PRODUCT CODE	PRICE	SIZE/ INCHES			WEIGHT LBS	VOL FT ³
		H	W	D		
EVPB6CEPA206	98	6	3	3	2	0.07
EVPB6CEPA212	98	12	3	3	4	0.14
EVPB6CEPA218	153	18	3	3	6	0.21
EVPB6CEPA224	153	24	3	3	8	0.28

EVPB6CEPA1 • Power Beam 60 Degree Corner Extension Post 1 Way



- Connects one extension module in 120 degree configuration.
- Includes one extension post, three non slotted extension connectors for power beam, connecting hardware and trim kit.
- Power Beam Corner Extension Post is not stackable.

PRODUCT CODE	PRICE	SIZE/ INCHES			WEIGHT LBS	VOL FT ³
		H	W	D		
EVPB6CEPA106	65	6	3	3	2	0.07
EVPB6CEPA112	69	12	3	3	4	0.14
EVPB6CEPA118	94	18	3	3	6	0.21
EVPB6CEPA124	94	24	3	3	8	0.28

EVPB24CPA • Panel to 24" H Power Beam 4 Way Corner Post



- Connects two panels and two 24" H power beams in 90 degree configuration.
- Post and connecting hardware add 3.25" to power beam run.
- Includes post, panel connectors and power beam connectors, post with trim all around, levelling glide, hardware and trim kit
- Pass thru only for power beam.

PRODUCT CODE	PRICE	SIZE/ INCHES			WEIGHT LBS	VOL FT ³
		H	W	D		
EVPB24CPA430	240	30	3	3	15.5	0.41
EVPB24CPA436	312	36	3	3	18	0.48
EVPB24CPA442	312	42	3	3	21	0.57

EVPB30CPA • Panel to 30" H Power Beam 4 Way Corner Post



- Connects two panels and two 24" H power beams in 90 degree configuration.
- Post and connecting hardware add 3.25" to power beam run.
- Includes post, panel connectors and power beam connectors, post with trim all around, levelling glide, hardware and trim kit.
- Pass thru only for power beam.

PRODUCT CODE	PRICE	SIZE/ INCHES			WEIGHT VOL	
		H	W	D	LBS	FT ³
EVPB30CPA430	240	30	3	3	15.5	0.41
EVPB30CPA436	312	36	3	3	18	0.48
EVPB30CPA442	312	42	3	3	21	0.57

EVPB36CPA • Panel to 36" H Power Beam 4 Way Corner Post



- Connects two panels and two 24" H power beams in 90 degree configuration.
- Post and connecting hardware add 3.25" to power beam run.
- Includes post, panel connectors and power beam connectors, post with trim all around, levelling glide, hardware and trim kit.
- Pass thru only for power beam.

PRODUCT CODE	PRICE	SIZE/ INCHES			WEIGHT VOL	
		H	W	D	LBS	FT ³
EVPB36CPA436	312	36	3	3	18	0.48
EVPB36CPA442	312	42	3	3	21	0.57

EVPB24CPSA4 • Panel to 24" H Power Beam 4 Way Corner Post - Slotted



- Connects two panels and two 24" H power beams in a 90 degree configuration.
- Post and connecting hardware add 3.25" to the power beam run.
- Includes post, panel connectors, power beam connectors, post with trim all around, levelling glide, hardware and trim kit.
- Pass thru only for power beam, power beam leg slotted.

PRODUCT CODE	PRICE	SIZE/ INCHES			WEIGHT VOL	
		H	W	D	LBS	FT ³
EVPB24CPSA430	240	30	3	3	15.5	0.41
EVPB24CPSA436	312	36	3	3	18	0.48
EVPB24CPSA442	312	42	3	3	21	0.57

EVPB30CPSA4 • Panel to 30" H Power Beam 4 Way Corner Post - Slotted



- Connects two panels and two 30" H power beams in a 90 degree configuration.
- Post and connecting hardware add 3.25" to the power beam run.
- Includes post, panel connectors, power beam connectors, post with trim all around, levelling glide, hardware and trim kit.
- Pass thru only for power beam, power beam leg slotted.

PRODUCT CODE	PRICE	SIZE/ INCHES			WEIGHT VOL	
		H	W	D	LBS	FT ³
EVPB30CPSA430	240	30	3	3	15.5	0.41
EVPB30CPSA436	312	36	3	3	18	0.48
EVPB30CPSA442	312	42	3	3	21	0.57

EVPB36CPSA4 • Panel to 36" H Power Beam 4 Way Corner Post - Slotted



- Connects two panels and two 36" H power beams in a 90 degree configuration.
- Post and connecting hardware add 3.25" to the power beam run.
- Includes post, panel connectors, power beam connectors, post with trim all around, levelling glide, hardware and trim kit.
- Pass thru only for power beam, power beam leg slotted.

PRODUCT CODE	PRICE	SIZE/ INCHES			WEIGHT VOL	
		H	W	D	LBS	FT ³
EVPB36CPSA436	312	36	3	3	18	0.48
EVPB36CPSA442	312	42	3	3	21	0.57

EVPB24CPA • Panel to 24" H Power Beam 3 Way Corner Post



- Connects panels and 24" H power beams in 90 degree configuration.
- Post and connecting hardware add 3.25" to power beam run.
- Includes post, panel connectors and power beam connectors, post with trim all around, levelling glide, hardware and trim kit.
- Pass thru only for power beam.

PRODUCT CODE	PRICE	SIZE/ INCHES			WEIGHT VOL	
		H	W	D	LBS	FT ³
EVPB24CPA330	218	30	3	3	11.8	0.36
EVPB24CPA336	289	36	3	3	13	0.42
EVPB24CPA342	289	42	3	3	16.1	0.50

EVPB30CPA • Panel to 30" H Power Beam 3 Way Corner Post



- Connects panels and 30" H power beams in 90 degree configuration.
- Post and connecting hardware add 3.25" to power beam run.
- Includes post, panel connectors and power beam connectors, post with trim all around, levelling glide, hardware and trim kit.
- Pass thru only for power beam.

PRODUCT CODE	PRICE	SIZE/ INCHES			WEIGHT VOL	
		H	W	D	LBS	FT ³
EVPB30CPA330	218	30	3	3	11.8	0.36
EVPB30CPA336	289	36	3	3	13	0.42
EVPB30CPA342	289	42	3	3	16.1	0.50

EVPB36CPA • Panel to 36" H Power Beam 3 Way Corner Post



- Connects panels and 36" H power beams in 90 degree configuration.
- Post and connecting hardware add 3.25" to power beam run.
- Includes post, panel connectors and power beam connectors, post with trim all around, levelling glide, hardware and trim kit.
- Pass thru only for power beam.

PRODUCT CODE	PRICE	SIZE/ INCHES			WEIGHT VOL	
		H	W	D	LBS	FT ³
EVPB36CPA336	289	36	3	3	13	0.42
EVPB36CPA342	289	42	3	3	16.1	0.50

EVPB24CPSA3 • Panel to 24" H Power Beam 3 Way Corner Post - Slotted



- Connects panels and 24" H power beam in a 90 degree configuration.
- Post and connecting hardware add 3.25" to the power beam run.
- Includes post, panel connectors, power beam connectors, post with trim all around, levelling glide, hardware and trim kit.
- Pass thru only for power beam, power beam leg slotted.

PRODUCT CODE	PRICE	SIZE/INCHES			WEIGHT VOL	
		H	W	D	LBS	FT ³
EVPB24CPSA330	218	30	3	3	11.8	0.36
EVPB24CPSA336	289	36	3	3	13	0.42
EVPB24CPSA342	289	42	3	3	16.1	0.50

EVPB30CPSA3 • Panel to 30" H Power Beam 3 Way Corner Post - Slotted



- Connects panels and 30" H power beam in a 90 degree configuration.
- Post and connecting hardware add 3.25" to the power beam run.
- Includes post, panel connectors, power beam connectors, post with trim all around, levelling glide, hardware and trim kit.
- Pass thru only for power beam, power beam leg slotted.

PRODUCT CODE	PRICE	SIZE/INCHES			WEIGHT VOL	
		H	W	D	LBS	FT ³
EVPB30CPSA330	218	30	3	3	11.8	0.36
EVPB30CPSA336	289	36	3	3	13	0.42
EVPB30CPSA342	289	42	3	3	16.1	0.50

EVPB36CPSA3 • Panel to 36" H Power Beam 3 Way Corner Post - Slotted



- Connects panels and 36" H power beam in a 90 degree configuration.
- Post and connecting hardware add 3.25" to the power beam run.
- Includes post, panel connectors, power beam connectors, post with trim all around, levelling glide, hardware and trim kit.
- Pass thru only for power beam, power beam leg slotted.

PRODUCT CODE	PRICE	SIZE/INCHES			WEIGHT VOL	
		H	W	D	LBS	FT ³
EVPB36CPSA336	289	36	3	3	13	0.42
EVPB36CPSA342	289	42	3	3	16.1	0.50

EVPB24CPA • Panel to 24" H Power Beam 2 Way Corner Post



- Connects one panels and one 24" H power beams in 90 degree configuration.
- Post and connecting hardware add 3.25" to power beam run.
- Includes post, panel connectors and power beam connectors, post with trim all around, levelling glide, hardware and trim kit.
- Pass thru only for power beam.

PRODUCT CODE	PRICE	SIZE/ H	INCHES		WEIGHT VOL	
			W	D	LBS	FT ³
EVPB24CPA230	183	30	3	3	8.5	0.31
EVPB24CPA236	227	36	3	3	11.5	0.37
EVPB24CPA242	227	42	3	3	15	0.43

EVPB30CPA • Panel to 30" H Power Beam 2 Way Corner Post



- Connects one panels and one 30" H power beams in 90 degree configuration.
- Post and connecting hardware add 3.25" to power beam run.
- Includes post, panel connectors and power beam connectors, post with trim all around, levelling glide, hardware and trim kit.
- Pass thru only for power beam.

PRODUCT CODE	PRICE	SIZE/ H	INCHES		WEIGHT VOL	
			W	D	LBS	FT ³
EVPB30CPA230	183	30	3	3	8.5	0.31
EVPB30CPA236	227	36	3	3	11.5	0.37
EVPB30CPA242	227	42	3	3	15	0.43

EVPB36CPA • Panel to 36" H Power Beam 2 Way Corner Post



- Connects one panels and one 36" H power beams in 90 degree configuration.
- Post and connecting hardware add 3.25" to power beam run.
- Includes post, panel connectors and power beam connectors, post with trim all around, levelling glide, hardware and trim kit.
- Pass thru only for power beam.

PRODUCT CODE	PRICE	SIZE/ H	INCHES		WEIGHT VOL	
			W	D	LBS	FT ³
EVPB36CPA236	227	36	3	3	11.5	0.37
EVPB36CPA242	227	42	3	3	15	0.43

EVPB24CPSA2 • Panel to 24" H Power Beam 2 Way Corner Post - Slotted



- Connects one panels and one 24" H power beams in 90 degree configuration.
- Post and connecting hardware add 3.25" to the power beam run.
- Includes post, panel connectors, power beam connectors, post with trim all around, levelling glide, hardware and trim kit.
- Pass thru only for power beam, power beam leg slotted.

PRODUCT CODE	PRICE	SIZE/INCHES			WEIGHT VOL	
		H	W	D	LBS	FT ³
EVPB24CPSA230	183	30	3	3	8.5	0.31
EVPB24CPSA236	227	36	3	3	11.5	0.37
EVPB24CPSA242	227	42	3	3	15	0.43

EVPB30CPSA2 • Panel to 30" H Power Beam 2 Way Corner Post - Slotted

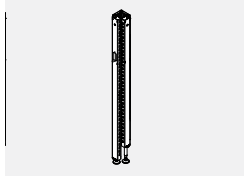

- Connects one panels and one 30" H power beams in 90 degree configuration.
- Post and connecting hardware add 3.25" to the power beam run.
- Includes post, panel connectors, power beam connectors, post with trim all around, levelling glide, hardware and trim kit.
- Pass thru only for power beam, power beam leg slotted.

PRODUCT CODE	PRICE	SIZE/INCHES			WEIGHT LBS	VOL FT ³
		H	W	D		
EVPB30CPSA230	183	30	3	3	8.5	0.31
EVPB30CPSA236	227	36	3	3	11.5	0.37
EVPB30CPSA242	227	42	3	3	15	0.43

EVPB36CPSA2 • Panel to 36" H Power Beam 2 Way Corner Post - Slotted

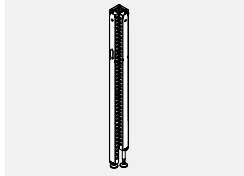

- Connects one panels and one 36" H power beams in 90 degree configuration.
- Post and connecting hardware add 3.25" to the power beam run.
- Includes post, panel connectors, power beam connectors, post with trim all around, levelling glide, hardware and trim kit.
- Pass thru only for power beam, power beam leg slotted.

PRODUCT CODE	PRICE	SIZE/INCHES			WEIGHT LBS	VOL FT ³
		H	W	D		
EVPB36CPSA236	227	36	3	3	11.5	0.37
EVPB36CPSA242	227	42	3	3	15	0.43

EVPB24CPA3-P • Panel to two 24" Power Beam 3 Way Corner Post

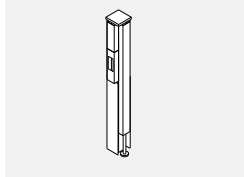

- Connects two 24" H power beams with panel in T configuration.
- Post and connecting hardware add 3.25" to power beam run.
- Includes post, panel connectors and power beam connectors, post with trim all around, levelling glide, hardware and trim kit.
- Pass thru only for power beam.

PRODUCT CODE	PRICE	SIZE/ INCHES			WEIGHT LBS	VOL FT ³
		H	W	D		
EVPB24CPA330P	208	30	3	3	11.8	0.36
EVPB24CPA336P	277	36	3	3	13	0.42
EVPB24CPA342P	277	42	3	3	16.1	0.5

EVPB30CPA3-P • Panel to two 30" Power Beam 3 Way Corner Post

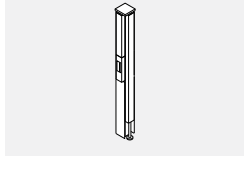

- Connects two 24" H power beams with panel in T configuration.
- Post and connecting hardware add 3.25" to power beam run.
- Includes post, panel connectors and power beam connectors, post with trim all around, levelling glide, hardware and trim kit.
- Pass thru only for power beam.

PRODUCT CODE	PRICE	SIZE/ INCHES			WEIGHT LBS	VOL FT ³
		H	W	D		
EVPB30CPA330P	208	30	3	3	11.8	0.36
EVPB30CPA336P	277	36	3	3	13	0.42
EVPB30CPA342P	277	42	3	3	16.1	0.5

EVPB36CPA3-P • Panel to two 36" Power Beam 3 Way Corner Post

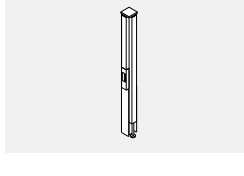

- Connects two 24" H power beams with panel in T configuration.
- Post and connecting hardware add 3.25" to power beam run.
- Includes post, panel connectors and power beam connectors, post with trim all around, levelling glide, hardware and trim kit.
- Pass thru only for power beam.

PRODUCT CODE	PRICE	SIZE/ INCHES			WEIGHT LBS	VOL FT ³
		H	W	D		
EVPB36CPA336P	277	36	3	3	13	0.42
EVPB36CPA342P	277	42	3	3	16.1	0.5

EVPB24CPSA3-P • Panel to two 24" H Power Beam 3 Way Corner Post



- Connects two 24" H power beams with panel in a T configuration.
- Post and connecting hardware add 3.25" to the power beam run.
- Includes post, panel connectors, power beam connectors, post with trim all around, levelling glide, hardware and trim kit.
- Pass thru only for power beam, power beam leg slotted.

PRODUCT CODE	PRICE	SIZE/INCHES			WEIGHT LBS	VOL FT ³
		H	W	D		
EVPB24CPSA330P	208	30	3	3	11.8	0.36
EVPB24CPSA336P	277	36	3	3	13	0.42
EVPB24CPSA342P	277	42	3	3	16.1	0.50

EVPB30CPSA3-P • Panel to two 30" H Power Beam 3 Way Corner Post



- Connects two 30" H power beams with panel in a T configuration.
- Post and connecting hardware add 3.25" to the power beam run.
- Includes post, panel connectors, power beam connectors, post with trim all around, levelling glide, hardware and trim kit.
- Pass thru only for power beam, power beam leg slotted.

PRODUCT CODE	PRICE	SIZE/INCHES			WEIGHT LBS	VOL FT ³
		H	W	D		
EVPB30CPSA330P	208	30	3	3	11.8	0.36
EVPB30CPSA336P	277	36	3	3	13	0.42
EVPB30CPSA342P	277	42	3	3	16.1	0.50

EVPB36CPSA3-P • Panel to two 36" H Power Beam 3 Way Corner Post

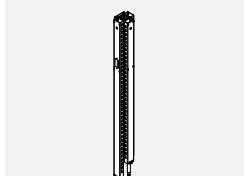

- Connects two 36" H power beams with panel in a T configuration.
- Post and connecting hardware add 3.25" to the power beam run.
- Includes post, panel connectors, power beam connectors, post with trim all around, levelling glide, hardware and trim kit.
- Pass thru only for power beam, power beam leg slotted.

PRODUCT CODE	PRICE	SIZE/INCHES			WEIGHT LBS	VOL FT ³
		H	W	D		
EVPB36CPSA336P	277	36	3	3	13	0.42
EVPB36CPSA342P	277	42	3	3	16.1	0.50

EVPFE • Fabric Panel Extension Module

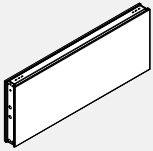

- Attaches on top of a panel.
- Module can be stacked to add privacy or divide space.
- Each side of fabric module may have different fabric within that same grade at no charge. If different grades of fabric are used, the entire module must be priced at highest grade.
- When ordering panel extension modules , additional connectors are required.
- Panel extension modules cannot be installed higher than 42" high above finished floor.

PRODUCT CODE	PRICE		SIZE/ INCHES			WEIGHT		VOL FT ³
	GR 1	GR 2	H	W	D	LBS		
EVPFE0618	153	160	6	18	2.875	4.80	0.21	
EVPFE0624	159	169	6	24	2.875	6.40	0.29	
EVPFE0630	174	183	6	30	2.875	7.40	0.36	
EVPFE0636	195	207	6	36	2.875	8.20	0.43	
EVPFE0642	217	233	6	42	2.875	9.40	0.51	
EVPFE0648	235	248	6	48	2.875	10.20	0.58	
EVPFE0654	253	271	6	54	2.875	14.40	0.65	
EVPFE0660	276	295	6	60	2.875	16.00	0.73	
EVPFE0666	298	317	6	66	2.875	17.6	0.91	
EVPFE0672	318	340	6	72	2.875	18.2	0.99	
EVPFE1218	153	160	12	18	2.875	7.40	0.38	
EVPFE1224	159	168	12	24	2.875	8.60	0.50	
EVPFE1230	174	183	12	30	2.875	9.60	0.63	
EVPFE1236	195	207	12	36	2.875	12.80	0.75	
EVPFE1242	217	231	12	42	2.875	14.80	0.88	
EVPFE1248	235	248	12	48	2.875	15.00	1.00	
EVPFE1254	253	271	12	54	2.875	16.20	1.12	
EVPFE1260	276	295	12	60	2.875	17.80	1.25	
EVPFE1266	298	317	12	66	2.875	19.0	1.37	
EVPFE1272	318	340	12	72	2.875	20.2	1.45	
EVPFE1818	190	201	18	18	2.875	9.01	0.54	
EVPFE1824	197	211	18	24	2.875	10.47	0.72	
EVPFE1830	212	234	18	30	2.875	11.93	0.90	
EVPFE1836	246	268	18	36	2.875	13.39	1.08	
EVPFE1842	274	301	18	42	2.875	14.84	1.26	
EVPFE1848	298	328	18	48	2.875	16.29	1.44	
EVPFE1854	324	355	18	54	2.875	17.76	1.62	
EVPFE1860	352	382	18	60	2.875	19.21	1.80	
EVPFE1866	382	406	18	66	2.875	20.7	1.98	
EVPFE1872	409	435	18	72	2.875	22.2	2.16	

EVPGTE • Tempered Glass Panel Extension Module

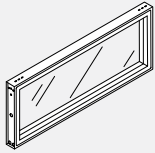

- Attaches on top of a panel.
- Module can be stacked to add privacy or divide space.
- Panel extension module is not load bearing above 66" high.
- Standard in lear (CLR).
- Frosted glass (FRST) upcharge varies. Contact Evolve customer service representative for details.
- When ordering panel extension modules, additional connectors are required.

PRODUCT CODE	PRICE	SIZE/ INCHES			WEIGHT LBS	VOL FT ³
		H	W	D		
EVPGTE0618	305	6	18	2.875	7.60	0.18
EVPGTE0624	328	6	24	2.875	9.24	0.25
EVPGTE0630	397	6	30	2.875	10.78	0.31
EVPGTE0636	412	6	36	2.875	12.32	0.37
EVPGTE0642	508	6	42	2.875	14.10	0.43
EVPGTE0648	567	6	48	2.875	15.80	0.50
EVPGTE0654	621	6	54	2.875	17.42	0.56
EVPGTE0660	666	6	60	2.875	19.28	0.63
EVPGTE0666	714	6	66	2.875	21.1	0.91
EVPGTE0672	766	6	72	2.875	22.9	0.99
EVPGTE1218	305	12	18	2.875	10.06	0.38
EVPGTE1224	328	12	24	2.875	12.08	0.50
EVPGTE1230	397	12	30	2.875	14.10	0.63
EVPGTE1236	412	12	36	2.875	16.12	0.75
EVPGTE1242	508	12	42	2.875	18.24	0.88
EVPGTE1248	567	12	48	2.875	20.56	1.00
EVPGTE1254	621	12	54	2.875	22.66	1.12
EVPGTE1260	666	12	60	2.875	25.00	1.25
EVPGTE1266	714	12	66	2.875	27.4	1.37
EVPGTE1272	766	12	72	2.875	29.9	1.45
EVPGTE1818	459	18	18	2.875	12.00	0.54
EVPGTE1824	473	18	24	2.875	14.93	0.72
EVPGTE1830	505	18	30	2.875	17.77	0.90
EVPGTE1836	551	18	36	2.875	20.57	1.08
EVPGTE1842	627	18	42	2.875	23.31	1.26
EVPGTE1848	701	18	48	2.875	25.94	1.44
EVPGTE1854	762	18	54	2.875	28.51	1.62
EVPGTE1860	819	18	60	2.875	31.28	1.80
EVPGTE1866	874	18	66	2.875	33.9	1.98
EVPGTE1872	935	18	72	2.875	35.7	2.16

EVPW1SE • Write Board Extension Module - One Side

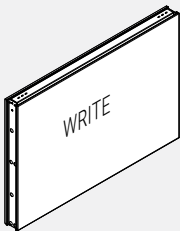

- Attaches on top of a beam.
- Provides writing surface on one side and fabric on the other side.
- Modules can be stacked to add privacy or to divide space.
- Panel Extension Modules cannot install higher than 42" high above finished floor.
- When ordering Beam Extension Modules, additional connectors are required.

PRODUCT CODE	PRICE		SIZE/ INCHES			WEIGHT LBS	VOL FT ³
	GR1	GR2	H	W	D		
EVPW1SE1818	233	237	18	18	2.875	9.44	0.54
EVPW1SE1824	263	270	18	24	2.875	10.90	0.72
EVPW1SE1830	293	303	18	30	2.875	12.35	0.90
EVPW1SE1836	344	355	18	36	2.875	13.81	1.08
EVPW1SE1842	389	405	18	42	2.875	15.27	1.26
EVPW1SE1848	430	448	18	48	2.875	16.72	1.44
EVPW1SE1854	465	483	18	54	2.875	18.18	1.62
EVPW1SE1860	503	520	18	60	2.875	19.64	1.80
EVPW1SE1866	540	557	18	66	2.875	21.70	1.98
EVPW1SE1872	577	593	18	72	2.875	23.30	2.16

EVPW2SE • Write Board Extension Module - Two Side

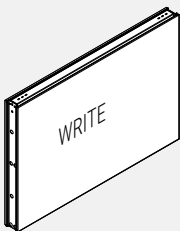

- Attaches on top of a panel.
- Provides writing surface on two sides.
- Modules can be stacked to add privacy or to divide space.
- Panel Extension Modules cannot install higher than 42" h above finished floor
- When ordering Panel Extension Modules, additional connectors are required.

PRODUCT CODE	PRICE	SIZE/ INCHES			WEIGHT LBS	VOL FT ³
		H	W	D		
EVPW2SE1818	279	18	18	2.875	10.29	0.54
EVPW2SE1824	328	18	24	2.875	11.75	0.72
EVPW2SE1830	375	18	30	2.875	13.20	0.90
EVPW2SE1836	446	18	36	2.875	14.66	1.08
EVPW2SE1842	503	18	42	2.875	16.12	1.26
EVPW2SE1848	562	18	48	2.875	17.57	1.44
EVPW2SE1854	622	18	54	2.875	19.03	1.62
EVPW2SE1860	678	18	60	2.875	20.49	1.80
EVPW2SE1866	733	18	66	2.875	21.70	1.98
EVPW2SE1872	792	18	72	2.875	23.30	2.16

EVPH1SE • Laminate Extension Module - One Side

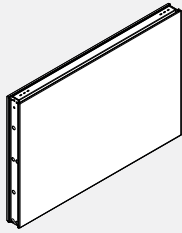

- Attaches on top of a beam.
- Laminate module provides a durable, washable surface on one side and fabric on the other side.
- Modules can be stacked to add privacy or to divide space.
- Panel Extension Modules cannot install higher than 42”h. above finished floor.
- When ordering Panel Extension Modules, additional connectors are required.
- Available in high pressure laminate finishes only.

PRODUCT CODE	PRICE		SIZE/ INCHES			WEIGHT LBS	VOL FT³
	GR 1	GR 2	H	W	D		
EVPH1SE0618	212	217	6	18	2.875	2.77	0.25
EVPH1SE0624	247	259	6	24	2.875	3.20	0.35
EVPH1SE0630	280	284	6	30	2.875	3.63	0.43
EVPH1SE0636	319	327	6	36	2.875	4.06	0.51
EVPH1SE0642	361	367	6	42	2.875	4.49	0.60
EVPH1SE0648	394	404	6	48	2.875	4.91	0.68
EVPH1SE0654	446	454	6	54	2.875	5.34	0.76
EVPH1SE0660	469	477	6	60	2.875	5.77	0.84
EVPH1SE0666	488	500	6	66	3	17.6	0.91
EVPH1SE0672	542	550	6	72	3	18.2	0.99
EVPH1SE1218	212	217	12	18	2.875	5.55	0.51
EVPH1SE1224	247	259	12	24	2.875	6.41	0.71
EVPH1SE1230	280	284	12	30	2.875	7.26	0.87
EVPH1SE1236	319	327	12	36	2.875	8.12	1.03
EVPH1SE1242	361	367	12	42	2.875	8.98	1.20
EVPH1SE1248	394	404	12	48	2.875	9.83	1.36
EVPH1SE1254	446	454	12	54	2.875	10.69	1.53
EVPH1SE1260	469	477	12	60	2.875	11.55	1.69
EVPH1SE1266	488	500	12	66	3	19.0	1.37
EVPH1SE1272	542	550	12	72	3	20.2	1.45
EVPH1SE1818	276	281	18	18	2.875	9.44	0.54
EVPH1SE1824	340	347	18	24	2.875	10.90	0.72
EVPH1SE1830	391	401	18	30	2.875	12.35	0.90
EVPH1SE1836	448	457	18	36	2.875	13.81	1.08
EVPH1SE1842	505	518	18	42	2.875	15.27	1.26
EVPH1SE1848	553	570	18	48	2.875	16.72	1.44
EVPH1SE1854	602	619	18	54	2.875	18.18	1.62
EVPH1SE1860	660	687	18	60	2.875	19.64	1.80
EVPH1SE1866	723	755	18	66	3	20.7	1.98
EVPH1SE1872	770	802	18	72	3	22.2	2.16

EVPH2SE • Laminate Extension Module - Two Sides

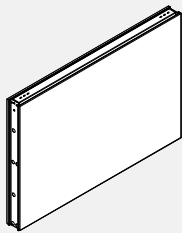

- Attaches on top of a beam.
- Laminate faces on both sides of the module provide durable, washable surfaces
- Modules can be stacked to add privacy or to divide space.
- Panel Extension Modules cannot install higher than 42”h. above finished floor.
- When ordering Panel Extension Modules, additional connectors are required.
- Available in high pressure laminate finishes only.

PRODUCT CODE	PRICE		SIZE/ INCHES			WEIGHT LBS	VOL FT³
	GR 1	GR 2	H	W	D		
EVPH2SE0618	234		6	18	2.875	3.03	0.26
EVPH2SE0624	274		6	24	2.875	3.46	0.36
EVPH2SE0630	318		6	30	2.875	3.89	0.44
EVPH2SE0636	364		6	36	2.875	4.32	0.52
EVPH2SE0642	410		6	42	2.875	4.74	0.60
EVPH2SE0648	460		6	48	2.875	5.17	0.69
EVPH2SE0654	535		6	54	2.875	5.60	0.77
EVPH2SE0660	544		6	60	2.875	6.03	0.85
EVPH2SE0666	555		6	66	2.875	21.1	0.91
EVPH2SE0672	627		6	72	2.875	22.9	0.99
EVPH2SE1218	234		12	18	2.875	6.05	0.51
EVPH2SE1224	274		12	24	2.875	6.91	0.71
EVPH2SE1230	318		12	30	2.875	7.77	0.88
EVPH2SE1236	364		12	36	2.875	8.63	1.04
EVPH2SE1242	410		12	42	2.875	9.48	1.20
EVPH2SE1248	460		12	48	2.875	10.34	1.37
EVPH2SE1254	535		12	54	2.875	11.20	1.53
EVPH2SE1260	544		12	60	2.875	12.05	1.70
EVPH2SE1266	555		12	66	2.875	27.4	1.37
EVPH2SE1272	627		12	72	2.875	29.9	1.45
EVPH2SE1818	329		18	18	2.875	10.29	0.54
EVPH2SE1824	404		18	24	2.875	11.75	0.72
EVPH2SE1830	469		18	30	2.875	13.20	0.90
EVPH2SE1836	542		18	36	2.875	14.66	1.08
EVPH2SE1842	614		18	42	2.875	16.12	1.26
EVPH2SE1848	694		18	48	2.875	17.57	1.44
EVPH2SE1854	762		18	54	2.875	19.03	1.62
EVPH2SE1860	823		18	60	2.875	20.49	1.80
EVPH2SE1866	882		18	66	2.875	33.9	1.98
EVPH2SE1872	949		18	72	2.875	35.7	2.16

EVPAE • Air Flow Extension Module

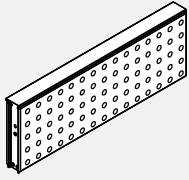

- Metal air flow panel extension.
- Attaches to top of beam.
- Modules can be stacked to add privacy or to divide space.
- Panel Extension Modules cannot install higher than 42”h. above finished floor.
- When ordering Panel Extension Modules, additional connectors are required.

PRODUCT CODE	PRICE	SIZE/ INCHES			WEIGHT LBS	VOL FT ³
		H	W	D		
EVPAE1224	270	12	24	2.875	9.66	0.59
EVPAE1230	318	12	30	2.875	10.93	0.82
EVPAE1236	363	12	36	2.875	12.19	1.00
EVPAE1242	401	12	42	2.875	13.62	1.05
EVPAE1248	452	12	48	2.875	15.18	1.18
EVPAE1260	596	12	60	2.875	18.17	1.32
EVPAE1824	339	18	24	2.875	10.56	0.72
EVPAE1830	394	18	30	2.875	12.11	0.90
EVPAE1836	435	18	36	2.875	13.66	1.08
EVPAE1842	478	18	42	2.875	15.05	1.26
EVPAE1848	547	18	48	2.875	16.35	1.44
EVPAE1860	711	18	60	2.875	19.04	1.80

EVPOE • Open Panel Extension Module

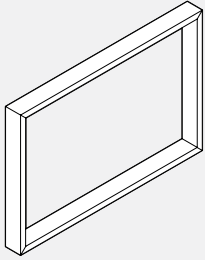

- Attaches to top portion of a beam.
- Modules can be stacked to add privacy or to divide space.
- Panel Extension Modules cannot install higher than 42”h above finished floor.
- When ordering Panel Extension Modules, additional connectors are required.

PRODUCT CODE	PRICE	SIZE/ INCHES			WEIGHT LBS	VOL FT ³
		H	W	D		
EVPOE0618	246	6	18	2.875	6.22	0.26
EVPOE0624	252	6	24	2.875	7.40	0.29
EVPOE0630	307	6	30	2.875	8.48	0.36
EVPOE0636	323	6	36	2.875	9.56	0.43
EVPOE0642	392	6	42	2.875	10.88	0.51
EVPOE0648	442	6	48	2.875	12.12	0.58
EVPOE0654	483	6	54	2.875	13.25	0.65
EVPOE0660	520	6	60	2.875	14.68	0.73
EVPOE1218	246	12	18	2.875	7.30	0.51
EVPOE1224	252	12	24	2.875	8.40	0.59
EVPOE1230	307	12	30	2.875	9.50	0.82
EVPOE1236	323	12	36	2.875	10.60	1.00
EVPOE1242	392	12	42	2.875	11.84	1.00
EVPOE1248	442	12	48	2.875	13.20	1.18
EVPOE1254	483	12	54	2.875	14.38	1.25
EVPOE1260	520	12	60	2.875	15.80	1.32
EVPOE1818	329	18	18	2.875	7.74	0.54
EVPOE1824	369	18	24	2.875	9.18	0.72
EVPOE1830	392	18	30	2.875	10.53	0.90
EVPOE1836	431	18	36	2.875	11.88	1.08
EVPOE1842	485	18	42	2.875	13.09	1.26
EVPOE1848	546	18	48	2.875	14.22	1.44
EVPOE1854	592	18	54	2.875	15.28	1.62
EVPOE1860	638	18	60	2.875	16.56	1.80

EVPMP-GIP • Panel Mount Privacy Glass

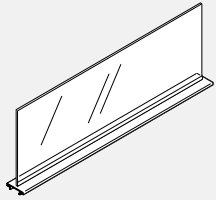

- Attaches on top of Power Beam or extension modules to add privacy or divide space.
- Privacy Glass is integrated into the aluminum top trim.
- Includes aluminum trim with channel and glass tile
- Glass and attachment hardware ship separately.
- Standard in clear (CLR), frosted (FRST) or writeable (WRW) glass.
- Privacy glass modules may stack on top of Power Beam or extension modules at 42" h. to achieve a height up to 54"h. above finished floor

PRODUCT CODE	PRICE CLR	FRST	WRW	SIZE/ INCHES			WEIGHT LBS	VOL FT³
				H	W	D		
EVPMP24GI6P	201	251	-	6	24	2.875	2.39	0.25
EVPMP30GI6P	219	276	-	6	30	2.875	2.99	0.32
EVPMP36GI6P	235	291	-	6	36	2.875	3.58	0.37
EVPMP42GI6P	251	313	-	6	42	2.875	4.18	0.43
EVPMP48GI6P	262	327	-	6	48	2.875	4.78	0.50
EVPMP54GI6P	270	338	-	6	54	2.875	5.38	0.56
EVPMP60GI6P	276	343	-	6	60	2.875	5.97	0.63
EVPMP66GI6P	422	562	-	6	66	2.875	6.57	0.69
EVPMP72GI6P	450	587	-	6	72	2.875	7.16	0.76
EVPMP24GI9P	201	251	-	9	24	2.875	3.58	0.38
EVPMP30GI9P	219	276	-	9	30	2.875	4.48	0.47
EVPMP36GI9P	235	291	-	9	36	2.875	5.37	0.56
EVPMP42GI9P	251	313	-	9	42	2.875	6.26	0.65
EVPMP48GI9P	262	327	-	9	48	2.875	7.16	0.75
EVPMP54GI9P	270	338	-	9	54	2.875	8.06	0.84
EVPMP60GI9P	276	343	-	9	60	2.875	8.96	0.94
EVPMP66GI9P	422	562	-	9	66	2.875	9.85	1.04
EVPMP72GI9P	450	587	-	9	72	2.875	10.74	1.13
EVPMP24GIP	201	251	350	12	24	2.875	4.77	0.50
EVPMP30GIP	219	276	357	12	30	2.875	5.97	0.63
EVPMP36GIP	235	291	364	12	36	2.875	7.16	0.75
EVPMP42GIP	251	313	401	12	42	2.875	8.35	0.87
EVPMP48GIP	262	327	439	12	48	2.875	9.55	1.00
EVPMP54GIP	270	338	475	12	54	2.875	10.75	1.12
EVPMP60GIP	276	343	512	12	60	2.875	11.95	1.25
EVPMP66GIP	422	562	701	12	66	2.875	13.05	1.37
EVPMP72GIP	450	587	734	12	72	2.875	14.25	1.51
EVPMP24GI18P	289	363	-	18	24	2.875	7.16	0.75
EVPMP30GI18P	317	397	-	18	30	2.875	8.96	0.94
EVPMP36GI18P	338	420	-	18	36	2.875	10.74	1.13
EVPMP42GI18P	363	453	-	18	42	2.875	12.53	1.31
EVPMP48GI18P	375	471	-	18	48	2.875	14.33	1.50
EVPMP54GI18P	388	485	-	18	54	2.875	16.13	1.69
EVPMP60GI18P	397	496	-	18	60	2.875	17.91	1.88
EVPMP66GI18P	553	733	-	18	66	2.875	19.70	2.06
EVPMP72GI18P	588	766	-	18	72	2.875	21.48	2.25

EVPBSCGD • Power Beam Shared Storage Cabinet with Sliding Glass Door

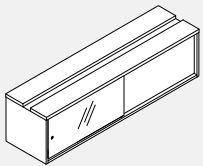

Left Hand Shown

- Inside dimensions 13"high x 13"deep.
- Laminate storage cabinet, available in standard Evolve laminate finishes.
- Available in Tempered frosted glass only, glass with handle.
- Tracks for sliding glass available in Tungsten only.
- To be installed under power beam between T legs.
- Power Beam Storage cabinet attaches to the bottom of the power beam with brackets.
- For ease of installation, levelers in middle included.
- **Note: To be used with 24"h. Power Beam only.**

PRODUCT CODE	PRICE	SIZE/ INCHES			WEIGHT LBS	VOL FT³
		H	W	D		
EVPBSCGDR60	1786	15	58.75	16	80.46	8.33
EVPBSCGDR72	1950	15	70.75	16	96.60	10.00
EVPBSCGDL60	1786	15	58.75	16	80.46	8.33
EVPBSCGDL72	1950	15	70.75	16	96.60	10.00

EVPBSCGDP • Power Beam Shared Storage Cabinet with Sliding Glass Door and Cable Pass Through

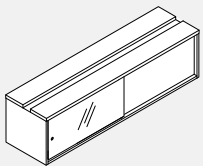

Left Hand Shown

- Inside dimensions 13"high x 13"deep.
- Laminate storage cabinet, available in standard Evolve laminate finishes.
- Available in Tempered frosted glass only, glass with handle.
- Tracks for sliding glass available in Tungsten only.
- To be installed under power beam between T legs.
- Power Beam Storage cabinet attaches to the bottom of the power beam with brackets.
- For ease of installation, levelers in middle included.
- **Note: To be used with 24"h. Power Beam only, EVPBEP-KIT and 60" and 72" widths only.**
- Cabinet with cable pass through in the middle to bring power to power beam above
- Includes metal cover for easy access to wires
- Electrics not included
- Power beam base feed to be ordered separately.
- Power beam kit with electrical cut out in middle to be ordered separately. (EVPBEP-KIT)

PRODUCT CODE	PRICE	SIZE/ INCHES			WEIGHT LBS	VOL FT³
		H	W	D		
EVPBSCGDPR60	2155	15	58.75	16	80.46	8.33
EVPBSCGDPR72	2279	15	70.75	16	96.60	10.00
EVPBSCGDPL60	2155	15	58.75	16	80.46	8.33
EVPBSCGDPL72	2279	15	70.75	16	96.60	10.00

EVPBSC • Power Beam Shared Storage Cabinet, Open

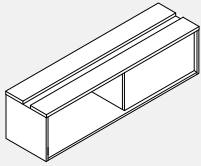

- Inside dimensions 13"high x 13"deep.
- Laminate storage cabinet, without doors, available in standard Evolve laminate finishes.
- To be installed under power beam between T legs.
- Power Beam Storage cabinet attaches to bottom of power beam with brackets.
- For ease of installation, levelers in middle included.
- Note: It can not be converted to cabinet with glass door.
- **Note: To be used with 24" h Power Beam only.**

PRODUCT CODE	PRICE	SIZE/ INCHES			WEIGHT VOL	
		H	W	D	LBS	FT ³
EVPBSCR60	1143	15	58.75	16	80.46	8.33
EVPBSCR72	1167	15	70.75	16	96.6	10.00
EVPBSCCL60	1143	15	58.75	16	80.46	8.33
EVPBSCCL72	1167	15	70.75	16	96.6	10.00

EVPBSCP • Power Beam Shared Storage Cabinet, Open and Cable Pass Through

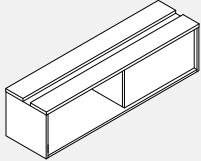

Left Hand Shown

- Inside dimensions 13"high x 13"deep.
- Laminate storage cabinet, without doors, available in standard Evolve laminate finishes.
- To be installed under power beam between T legs.
- Power Beam Storage cabinet attaches to bottom of power beam with brackets.
- For ease of installation, levelers in middle included.
- Note: It can not be converted to cabinet with glass door.
- **Note: To be used with 24" h Power Beam only, EVPBBEP-KIT.**
- Cabinet with cable pass through in the middle to bring power to power beam above.
- Includes metal cover for easy access to wires.
- Electrics not included.
- Power beam base feed to be ordered separately.
- Power beam kit with electrical cut out in middle to be ordered separately. (EVPBEP-KIT).

PRODUCT CODE	PRICE	SIZE/ INCHES			WEIGHT VOL	
		H	W	D	LBS	FT ³
EVPBSCP60	1275	15	58.75	16	80.46	8.33
EVPBSCP72	1345	15	70.75	16	96.6	10.00
EVPBSCPL60	1275	15	58.75	16	80.46	8.33
EVPBSCPL72	1345	15	70.75	16	96.6	10.00

EVSDAOH • Power Beam Dual Access Overhead

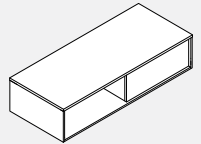

- Inside dimensions 6.5" high x 13"deep.
- Laminate Overhead.
- Available in standard Evolve laminate finishes.
- Power Beam storage cabinet must be installed at the bottom for stability.
- Top mount on power beam.
- Dual Access Overhead Support Brackets to be ordered separately.
- Power Beam legs for storage to be ordered separately.
- Power Beam legs for storage must be used.

PRODUCT CODE	PRICE	SIZE/ INCHES			WEIGHT VOL	
		H	W	D	LBS	FT ³
EVSDAOH60	1137	8.5	60	16	51.5	5.00
EVSDAOH72	1160	8.6	72	16	60.2	6.00

EVSDAOHBRKIT • Brackets for Dual Access Overhead

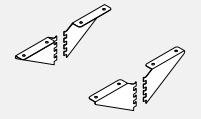

- Brackets support Dual access overhead
- To be used with Power Beam Channel
- Available in standard paint colors
- Brackets and screws included

PRODUCT CODE	PRICE	SIZE/INCHES			WEIGHT LBS	VOL FT ³
		H	W	D		
EVSDAOHBRKIT	133	5	5	1.5	2.00	0.08

EVPBL • 36" Power Beam Connector with Leg for Storage



- Connects 24" h power beams on equal height.
- Includes non slotted connector with leg, glides and connecting hardware.
- Must be used with overhead.

PRODUCT CODE	PRICE	SIZE/ INCHES			WEIGHT VOL	
		H	W	D	LBS	FT ³
EVPBL36S	112	36	18		8.5	0.45

EVPBLERT • End of Run Trim for Connector

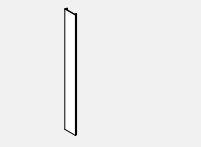

- Specify to match height of beam or total height with extension modules

PRODUCT CODE	PRICE	SIZE/ INCHES			WEIGHT VOL	
		H	W	D	LBS	FT ³
EVPBLERT24	54	21.4	2.875	3	1.0	0.04
EVPBLERT30	61	27.4	2.875	3	1.4	0.04
EVPBLERT36	64	33.4	2.875	3	1.6	0.06
EVPBLERT42	68	39.4	2.875	3	1.8	0.07
EVPBLERT48	71	45.4	2.875	3	2.00	0.08
EVPBLERT54	74	51.4	2.875	3	2.20	0.09
EVPBLERT66	85	63.4	2.875	3	2.60	1.10

EVPBLEP • Laminate End Panel for Power Beam

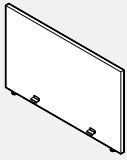

- Connects to a power beam support leg with foot at the end of a run
- Includes brackets to attach to support leg with foot
- Finished in thermally fused laminate. If wood grain is selected, grain runs horizontally
- Laminate End Panel height is inclusive of panel glides extended to their full height
- Laminate end panel must connect to a support leg with foot and will not connect to a support leg with glide
- Must be used with Connectors with T-Leg

PRODUCT CODE	PRICE	SIZE/ INCHES			WEIGHT VOL	
		H	W	D	LBS	FT ³
EVPBLEP2451	327	24	51	1	32.81	0.73
EVPBLEP3051	408	30	51	1	39.38	0.88
EVPBLEP3651	487	36	51	1	45.94	1.02
EVPBLEP4251	731	42	51	1	52.50	1.24
EVPBLEP2463	370	24	63	1	37.50	0.83
EVPBLEP3063	465	30	63	1	45.00	1.00
EVPBLEP3663	557	36	63	1	52.50	1.17
EVPBLEP4263	816	42	63	1	60.00	1.53

EVPBLEP • Laminate End Panel for Power Beam, Single Leg

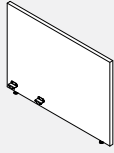

- EVPBLEP - Laminate End Panel for Power Beam.
- Attaches to power beam connector with single leg.
- For one sided Power beam application.
- Includes brackets to attached to attached to leg.
- Finished in thermally fused laminate, if wood grain is selected, grain runs horizontally.
- Laminate End Panel height is inclusive of panel glides extended to their full height.
- EVPBLEP-30 to be used for 24" deep worksurface.
- EVPBLEP-36 to be used for 30" deep worksurfaces

PRODUCT CODE	PRICE	SIZE/ INCHES			WEIGHT VOL	
		H	W	D	LBS	FT ³
EVPBLEP2430	265	24	30	1	19.30	0.42
EVPBLEP3030	287	30	30	1	23.16	0.52
EVPBLEP3630	309	36	30	1	27.02	0.64
EVPBLEP4230	388	42	30	1	30.88	0.74
EVPBLEP2436	312	24	36	1	21.43	0.55
EVPBLEP3036	323	30	36	1	25.71	0.64
EVPBLEP3636	364	36	36	1	30.00	0.75
EVPBLEP4236	465	42	36	1	34.29	0.90

EVE8PD • Power Distribution Housing

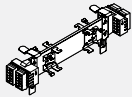

- Power housing is specified per beam size (e.g. EVE8PD36 is for use in a 36" beam).
- 8 wire, 4 circuits (2+2 configuration).
- Accommodates two duplex receptacles per panel side.

PRODUCT CODE	PRICE	SIZE/ INCHES		WEIGHT VOL	
		W	D	LBS	FT ³
EVE8PD24	156	24	9.25	0.83	1.17
EVE8PD30	208	30	15.25	1.28	1.17
EVE8PD36	220	36	21.25	1.62	1.65
EVE8PD42	226	42	27.25	2.00	2.00
EVE8PD48	238	48	33.25	0.18	0.16
EVE8PD54	242	54	39.25	2.66	3.20
EVE8PD60	243	60	45.25	3.04	3.20

EVE8PD • Power Distribution Housing

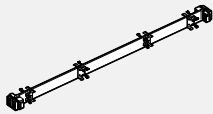

- Power housing is specified per beam size (e.g. EVE8PD72 is for use in a 72" beam).
- 8 wire, 4 circuits (2+2 configuration).
- Provides two duplex receptacle to be plugged directly to power distribution housing and then as option additional two duplex receptacle to be connected to it with "I" connector, per panel size.
- Both duplex receptacles connected by "I" connector must be same circuit.
- Each power distribution housing supports 15-20 amps.
- Duplex receptacles and "I" connectors to be ordered separately.

PRODUCT CODE	PRICE	SIZE/ INCHES		WEIGHT VOL	
		W	D	LBS	FT ³
EVE8PD66	253	66	43.5	3.44	3.30
EVE8PD72	262	72	45.5	3.84	3.40

EVE8CP • Jumper Cable

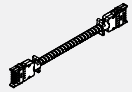

- The EVE8CP16 electrically connects two powered panels positioned side by side.
- The EVE8CP20 electrically connects two powered panels separated by a post.

PRODUCT CODE	PRICE	SIZE/ INCHES	WEIGHT VOL	
			L	LBS FT ³
EVE8CP16	121	16	0.66	1.17
EVE8CP20	142	20	0.78	1.17

EVE8CP18 • Flexible Mesh Jumper Cable

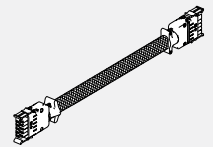

- Electrically connects two powered panels separated by post.
- Used to connect two power distribution housing in Power Beam at 90 degrees.

PRODUCT CODE	PRICE	SIZE/INCHES			WEIGHT VOL	
		H	W	D	LBS	FT ³
EVE8CP18	147			18.5	0.78	1.17

EVE8CP • Pass Through Cable

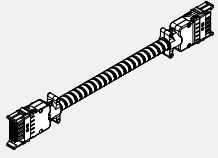

- Flexible metal conduit is used to distribute electrical power through non-powered panels.
- To calculate the length of a Pass-Through Cable, add the widths of the non-powered panels separating the powered panels (panels with distribution housing attached). To this, add 16" (distance from the edge of the panel to the distribution housing x 2). See Technical Information page at the beginning of this section.

PRODUCT CODE	PRICE	SIZE/ INCHES			WEIGHT VOL	
		L			LBS	FT ³
EVE8CP40	164	40			1.44	1.17
EVE8CP46	169	46			1.71	1.17
EVE8CP52	177	52			1.95	1.17
EVE8CP58	188	58			2.21	1.17
EVE8CP64	196	64			2.37	1.17
EVE8CP70	200	70			2.60	1.17
EVE8CP76	204	76			2.81	1.17
EVE8CP82	213	82			3.03	1.17
EVE8CP88	220	88			3.05	1.17
EVE8CP94	228	94			3.92	1.17
EVE8CP100	233	100			3.47	1.17
EVE8CP106	243	106			3.87	1.17
EVE8CP118	257	118			4.08	1.17
EVE8CP130	281	185			4.73	1.17
EVE8CP142	293	142			4.59	1.17

EVE8CPxx-H • Hybrid Pass Through Cables with Wire Mesh

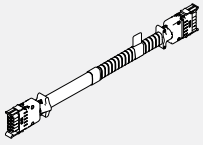

- Flexible metal conduit with wire mesh distributes electrical power through non powered panels.
- To calculate the length of Hybrid Pass Through Cable, add the width of non powered panels separating the powered panels. To this add 16" (distance from edge of the panels to power distribution housing x2).
- Please add an additional 3" when passing through a post. Please see the the beginning of this section.
- Hybrid Pass Through Cables with wire mesh allows connection at 90 degree post and one end for Power Beam.

PRODUCT CODE	PRICE	SIZE/INCHES			WEIGHT VOL	
		H	W	D	LBS	FT ³
EVE8CP40-H	196	40			1.44	1.17
EVE8CP46-H	204	46			1.71	1.17
EVE8CP52-H	212	52			1.95	1.17
EVE8CP58-H	226	58			2.21	1.17
EVE8CP64-H	235	64			2.37	1.17
EVE8CP70-H	240	70			2.60	1.17
EVE8CP76-H	244	76			2.81	1.17
EVE8CP82-H	255	82			3.03	1.17
EVE8CP88-H	264	88			3.05	1.17
EVE8CP94-H	273	94			3.42	1.17
EVE8CP100-H	281	100			3.47	1.17
EVE8CP106-H	292	106			3.87	1.17
EVE8CP118-H	309	118			4.08	1.17
EVE8CP130-H	337	130			4.73	1.17
EVE8CP142-H	351	142			4.89	1.17

EVE8CI-1 • "I" Connector



- Female - Female connector used to connect two Pass-Through Cables.

PRODUCT CODE	PRICE	SIZE/ INCHES			WEIGHT VOL	
		H	W	D	LBS	FT ³
EVE8CI-1	85	15	15	0.75	0.06	0.20

EVE8RD • Duplex Receptacles

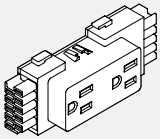

- Up to 6 duplex receptacles per circuit.
- EVE8RD1 = Circuit #1 (utility circuit)
- EVE8RD1 = Circuit #2 (utility circuit)
- EVE8RDA = Circuit #A (dedicated)
- EVE8RDB = Circuit #B (dedicated)

PRODUCT CODE	PRICE	SIZE/ INCHES			WEIGHT VOL	
		H	W	D	LBS	FT ³
EVE8RD1	35	2	4.625	1.25	0.16	0.01
EVE8RD2	35	2	4.625	1.25	0.16	0.01
EVE8RDA	35	2	4.625	1.25	0.16	0.01
EVE8RDB	35	2	4.625	1.25	0.16	0.01

EVEUSB01 • Duplex Receptacles

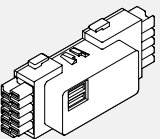

- The USB charging module provides convenient charging power access through dual ports on face of the receptacle.
- Two USB ports.
- 2 Amp output via two USB ports, considered as circuit #1.
- Available in white, black.

PRODUCT CODE	PRICE	SIZE/ INCHES			WEIGHT VOL	
		H	W	D	LBS	FT ³
EVEUSB01WHT	238	2	4.625	1.25	0.16	0.01
EVEUSB01BLK	238	2	4.625	1.25	0.16	0.01

EVE8FR3PB • Floor Power Entry for Power Beam

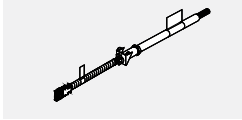

- Snaps into the power distribution housing.
- Includes 84" long flexible vinyl conduit.
- Includes bracket to attach to vertical raceway panel.
- Must be hard wire to source by licenced electrician.

PRODUCT CODE	PRICE	SIZE/ INCHES			WEIGHT VOL	
		H	W	D	LBS	FT ³
EVE8FR3PB	435	3	84	2	3.82	2.00

EVE8EC • Ceiling Power Entry

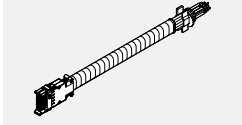

- Snaps into the end of the Power Distribution Housing.
- Flexible metal conduit extends into the ceiling through a corner post and post extension (both ordered separately).
- Must be hard wired to source power by a licensed electrician.
- 4" Junction Box included.

PRODUCT CODE	PRICE	SIZE/ INCHES			WEIGHT VOL	
		L	LBS	FT ³	LBS	FT ³
EVE8EC1	268	132	5.24	2.00		
EVE8EC2	479	144	5.96	2.00		

EVE8FR3PBP • Power Entry for Power Beam for Wall Plate Infeed

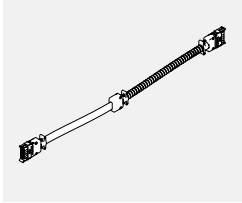

- Snaps into power distribution housing.
- Includes 48" long flexible vinyl conduit with connector.
- Includes bracket to attach to vertical raceway panel
- Power Beam with electrical cut out must be ordered.
- 71" long base feed will work with 24" and 36" H Power Beam.
- Note: EVE8FR3PBP will only work with Wall Plate Infeed EVE8WPIPB.

PRODUCT CODE	PRICE	SIZE/INCHES			WEIGHT VOL	
		H	W	D	LBS	FT ³
EVE8FR3PBP	373	3	71	2	3.82	2.00

EVE8WPIPB • Wall Plate Infeed for Power Beam

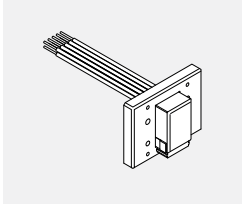

- Wall plate infeed must be installed and hardwired to source by licensed electrician.
- Note: EVE8FR3PBP will only work with Wall Plate Infeed EVE8WPIPB.

PRODUCT CODE	PRICE	SIZE/INCHES			WEIGHT VOL	
		H	W	D	LBS	FT ³
EVE8WPIPB	607	5.25	5.25	1.75	1.00	0.10

EVEJBC1PB • Hardwire Junction Box for Power Beam

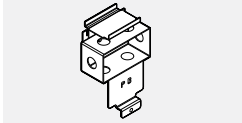

- Can be retrofitted in any size of panel at the receptacle location.
- Gives access from one side only at each location.
- Customer to supply conduit, wiring, receptacle, and face plate 2 per Power Beam.
- A licensed electrician must provide hard wire connection with the junction box.
- For use with Power Beam only.

PRODUCT CODE	PRICE	WEIGHT VOL	
		LBS	FT ³
EVEJBC1PB	105	1.50	0.02

EVDPE • Post Extension Data/Comm Lay-in

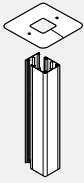

- Attaches to the top of a post to bring power and/or data cables from the ceiling to panel power way.
- Three-sided power pole with snap-on fourth side.
- Post extension can be opened on one side for lay-in for power and/or data cables.
- Made of aluminum and can be field cut.
- Accommodates up to 25 CAT5 cables with electric. Accommodates up to 45 CAT5 cables without electric.

PRODUCT CODE	PRICE	SIZE/ INCHES		WEIGHT LBS	VOL FT ³
		H	W		
EVDPE64	160	64	2.875	3.00	0.70
EVDPE82	197	82	2.875	4.20	0.80
EVDPE88	302	88	2.875	4.50	0.85
EVDPE94	323	94	2.875	4.80	0.92
EVDPE100	344	100	2.875	5.12	0.97

EVDP4E • 45° Post Extension Data/Comm Lay-in

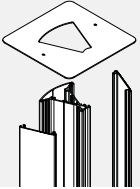

- Attached to the top of the 45° Corner Post to bring power and/or data cables from the ceiling to the panel run through.
- Cable capacity
 - 40 CAT5 cables without electric feed.
 - 10 CAT5 cables with electric feed.

PRODUCT CODE	PRICE	SIZE/ INCHES		WEIGHT LBS	VOL FT ³
		H	W		
EVDP4E64	162	64	3.65	3.00	0.70
EVDP4E82	218	82	3.65	4.20	0.80

EVDP6E • 60° Post Extension Data/Comm Lay-in

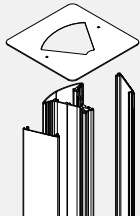

- Attached to the top of the 60° Corner Post to bring power and/or data cables from the ceiling to the panel run through.
- Post extension can be opened on one side for lay-in power and/or data cables.
- Made of aluminum and can be field cut.
- Two sided power pole with snap-on third side.
- Cable capacity
 - 32 CAT5 cables without electric.
 - 15 CAT5 cables with electric

PRODUCT CODE	PRICE	SIZE/ INCHES		WEIGHT LBS	VOL FT ³
		H	W		
EVDP6E64	157	64	2	3.00	0.70
EVDP6E82	192	82	2	4.20	0.80

EVPBECH34 • Wire Manager Kit



- Provides cable management from Power Beam to Height Adjustable Table.
- Includes bracket to attach to bottom trim of Power Beam.
- Cables fit easily.
- Includes a neoprene wire manager sock, bracket and screws.
- Neoprene available in black only.
- Specify bracket paint finish.

PRODUCT CODE	PRICE	SIZE/ INCHES			WEIGHT LBS	VOL FT ³
		H	W	D		
EVPBECH34	421	1	41	2	0.60	0.04

EVPBT01 • Power Beam Tray

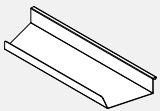

- Power beam tray provides support for wires.
- Can be used with power beam only.
- Available in standard and premium paint finishes.

PRODUCT CODE	PRICE	SIZE/ INCHES			WEIGHT LBS	VOL FT ³
		H	W	D		
EVPBT01	32	12	1.25	3.5	0.60	0.04

EVAFMB01 • Floor Mount Plate

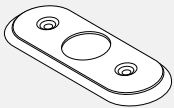

- Attached to floor.
- Secures panel to floor.
- Attachment screws not included.
- Care should be taken to use correct fasteners for type of floor.
- Available in chrome finish only.

PRODUCT CODE	PRICE	SIZE/ INCHES			WEIGHT LBS	VOL FT ³
		H	W	D		
EVAFMB01	72	0.25	5	2.5	0.2	0.02

WORKSURFACES • TECHNICAL INFORMATION

- All worksurfaces have threaded inserts for metal-to-metal connection of support hardware.
- Back edge features scoop detail and sits 3/8" away from the face of a panel for wire management. Scoop depth is 3/4" at centre.
- Communication and electrical wires are routed through the cable scoop at the back of the worksurface.
- Straight or Curvilinear Worksurfaces 48" or less have one scoop while those that are 54" or more two scoops. All other worksurface shapes have one scoop.

- LP and HP worksurfaces are 3.5 mm edge banded.
- LP worksurfaces are 1" thick particle board with laminate finish.
- HP worksurfaces are 1 1/16" thick particle board with laminate finish overall.
- All support hardware must be ordered separately.
- Wood grain laminates on corner worksurfaces may run diagonal to the adjacent worksurfaces. Specify "WG" at the end of the worksurface code.
- Please use "Wood Grain Direction" chart at the beginning of the price list.

WORKSURFACES • GUIDELINE FOR ORDERING PRODUCT

The price list uses a numbering system with meaningful alphanumeric characters to create a simple-to-understand product number. This makes specifying the product much easier and more accurate.

EXAMPLE OF WORKSURFACE CODE

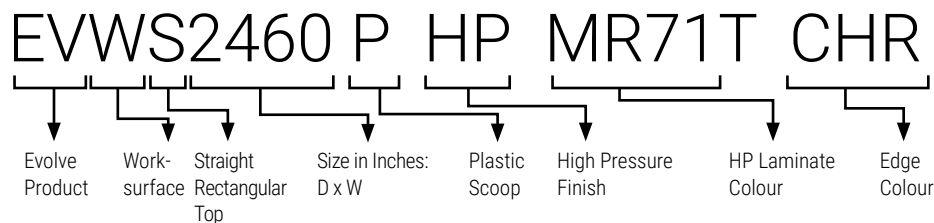

HOW TO SPECIFY

- Specify Evolve worksurface type and size by code.
- Specify type of finish.
- Specify High or LOW Pressure Laminate Colour.
- Specify PVC edge colour.

EVWS • Straight Worksurface

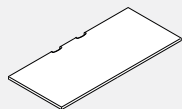

- Straight rectangular worksurfaces are non-handed and can be interchanged on site.
- Please choose from DWT - Designer White, SIL - Silver or BLK - Black for scoop covers.

PRODUCT CODE	PRICE		SIZE/ INCHES			WEIGHT VOL	
	LP	HP	H	W	D	LBS	FT³
EVWS1818P	127	161	1	18	18	12.50	0.37
EVWS1824P	131	174	1	24	18	13.50	0.40
EVWS1830P	138	183	1	30	18	16.50	0.54
EVWS1836P	159	210	1	36	18	19.50	0.63
EVWS1842P	208	278	1	42	18	23.25	0.73
EVWS1848P	249	328	1	48	18	26.25	0.83
EVWS1854P	293	385	1	54	18	29.25	0.93
EVWS1860P	329	422	1	60	18	33.00	1.02
EVWS1866P	344	452	1	66	18	36.75	1.12
EVWS1872P	363	478	1	72	18	39.75	1.21
EVWS1878P	380	503	1	78	18	38.50	1.23
EVWS1884P	417	546	1	84	18	39.75	1.21
EVWS1890P	542	797	1	90	18	48.75	1.53
EVWS1896P	578	852	1	96	18	51.75	1.73
EVWS2418P	131	168	1	18	24	12.00	0.50
EVWS2424P	133	178	1	24	24	18.00	0.60
EVWS2430P	145	190	1	30	24	22.00	0.72
EVWS2436P	161	213	1	36	24	26.00	0.85
EVWS2442P	211	280	1	42	24	31.00	0.98
EVWS2448P	252	339	1	48	24	35.00	1.11
EVWS2454P	299	394	1	54	24	39.00	1.23
EVWS2460P	336	443	1	60	24	44.00	1.36
EVWS2466P	350	462	1	66	24	49.00	1.49
EVWS2472P	366	484	1	72	24	53.00	1.62
EVWS2478P	392	516	1	78	24	57.18	2.16
EVWS2484P	422	553	1	84	24	61.50	2.33
EVWS2490P	542	797	1	90	24	64.50	2.53
EVWS2496P	578	852	1	96	24	68.50	2.73
EVWS3018P	149	192	1	18	30	15.30	0.63
EVWS3024P	159	208	1	24	30	22.00	0.74
EVWS3030P	170	225	1	30	30	28.00	0.90
EVWS3036P	200	264	1	36	30	33.00	1.06
EVWS3042P	283	373	1	42	30	38.00	1.22
EVWS3048P	299	394	1	48	30	44.00	1.38
EVWS3054P	327	420	1	54	30	49.00	1.54
EVWS3060P	350	462	1	60	30	55.00	1.69
EVWS3066P	364	483	1	66	30	60.00	1.85
EVWS3072P	385	510	1	72	30	66.00	2.01
EVWS3078P	410	540	1	78	30	71.48	2.70
EVWS3084P	456	596	1	84	30	76.98	2.92
EVWS3090P	676	998	1	90	30	81.98	3.12
EVWS3096P	722	1064	1	96	30	68.50	3.32
EVWS3672P	544	712	1	72	36	79.20	2.42

EVWS • Straight Worksurface to Span a Post

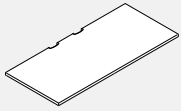

- Straight rectangular worksurfaces are non-handed and can be interchanged on site.
- Worksurface will span the width of a post eliminating a gap between standard sizes.
- Please choose from DWT - Designer White, SIL - Silver or BLK - Black for scoop covers.

PRODUCT CODE	PRICE		SIZE/ INCHES			WEIGHT VOL	
	LP	HP	H	W	D	LBS	FT ³
EVWSP1827P	138	183	1	27	18	16.50	0.54
EVWSP1833P	174	210	1	33	18	19.50	0.53
EVWSP1839P	208	278	1	39	18	23.25	0.73
EVWSP1845P	249	328	1	45	18	26.25	0.83
EVWSP1851P	293	385	1	51	18	29.25	0.93
EVWSP1857P	329	422	1	57	18	33.00	1.02
EVWSP1863P	344	452	1	63	18	36.75	1.12
EVWSP1869P	363	478	1	69	18	39.75	1.21
EVWSP1875P	380	503	1	75	18	42.75	1.33
EVWSP1881P	417	546	1	81	18	45.75	1.43
EVWSP2427P	145	190	1	27	24	22.00	0.72
EVWSP2433P	161	213	1	33	24	26.00	0.85
EVWSP2439P	211	280	1	39	24	31.00	0.98
EVWSP2445P	252	339	1	45	24	35.00	1.11
EVWSP2451P	299	394	1	51	24	39.00	1.23
EVWSP2457P	336	443	1	57	24	44.00	1.36
EVWSP2463P	350	462	1	63	24	49.00	1.49
EVWSP2469P	366	484	1	69	24	53.00	1.62
EVWSP2475P	392	516	1	75	24	57.18	2.16
EVWSP2481P	422	553	1	81	24	61.50	2.33
EVWSP3027P	170	225	1	27	30	28.00	0.90
EVWSP3033P	200	264	1	33	30	33.00	1.06
EVWSP3039P	283	373	1	39	30	38.00	1.22
EVWSP3045P	299	394	1	45	30	44.00	1.38
EVWSP3051P	327	420	1	51	30	49.00	1.54
EVWSP3057P	350	462	1	57	30	55.00	1.69
EVWSP3063P	364	483	1	63	30	60.00	1.85
EVWSP3069P	385	510	1	69	30	66.00	2.01
EVWSP3075P	410	540	1	75	30	71.48	2.70
EVWSP3081P	456	596	1	81	30	76.98	2.92

EVWVL • Curvilinear Worksurface Left

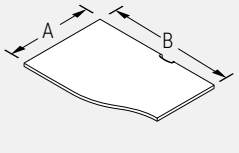

- When deepest end equals 24", the opposite depth is 18".
- When deepest end equals 30", the opposite depth is 24".
- Please choose from DWT - Designer White, SIL - Silver or BLK - Black for scoop covers.

NOTE: EVWV

24	36
A	B
DEPTH	WIDTH

PRODUCT CODE	PRICE		SIZE/ INCHES			WEIGHT VOL	
	LP	HP	H	W	D	LBS	FT ³
EVWVL2424P	172	233	1	24	24	15.00	0.59
EVWVL2430P	182	240	1	30	24	19.00	0.72
EVWVL2436P	217	289	1	36	24	23.00	0.85
EVWVL2442P	252	339	1	42	24	27.00	0.98
EVWVL2448P	289	385	1	48	24	31.00	1.11
EVWVL2454P	327	433	1	54	24	35.00	1.23
EVWVL2460P	354	483	1	60	24	39.00	1.36
EVWVL2466P	392	528	1	66	24	43.00	1.49
EVWVL2472P	420	578	1	72	24	47.00	1.62
EVWVL3024P	174	239	1	24	30	19.00	0.74
EVWVL3030P	192	251	1	30	30	24.00	0.90
EVWVL3036P	229	289	1	36	30	29.00	1.06
EVWVL3042P	312	412	1	42	30	34.00	1.22
EVWVL3048P	327	433	1	48	30	39.00	1.38
EVWVL3054P	364	483	1	54	30	44.00	1.54
EVWVL3060P	391	528	1	60	30	49.00	1.69
EVWVL3066P	420	578	1	66	30	54.00	1.85
EVWVL3072P	451	626	1	72	30	59.00	2.01
EVWVL3078P	653	833	1	78	30	71.48	2.71
EVWVL3084P	833	850	1	84	30	76.98	2.91

EVWVR • Curvilinear Worksurface Right

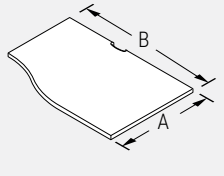

- When deepest end equals 24", the opposite depth is 18".
- When deepest end equals 30", the opposite depth is 24".
- Please choose from DWT - Designer White, SIL - Silver or BLK - Black for scoop covers.

NOTE: EVWV

24	36
A	B
DEPTH	WIDTH

PRODUCT CODE	PRICE		SIZE/ INCHES			WEIGHT VOL	
	LP	HP	H	W	D	LBS	FT ³
EVWVR2424P	172	233	1	24	24	15.00	0.59
EVWVR2430P	182	240	1	30	24	19.00	0.72
EVWVR2436P	217	289	1	36	24	23.00	0.85
EVWVR2442P	252	339	1	42	24	27.00	0.98
EVWVR2448P	289	385	1	48	24	31.00	1.11
EVWVR2454P	327	433	1	54	24	35.00	1.23
EVWVR2460P	354	483	1	60	24	39.00	1.36
EVWVR2466P	392	528	1	66	24	43.00	1.49
EVWVR2472P	420	578	1	72	24	47.00	1.62
EVWVR3024P	174	239	1	24	30	19.00	0.74
EVWVR3030P	192	251	1	30	30	24.00	0.90
EVWVR3036P	229	289	1	36	30	29.00	1.06
EVWVR3042P	312	412	1	42	30	34.00	1.22
EVWVR3048P	327	433	1	48	30	39.00	1.38
EVWVR3054P	364	483	1	54	30	44.00	1.54
EVWVR3060P	391	528	1	60	30	49.00	1.69
EVWVR3066P	420	578	1	66	30	54.00	1.85
EVWVR3072P	451	626	1	72	30	59.00	2.01
EVWVR3078P	653	833	1	78	30	71.48	2.71
EVWVR3084P	757	850	1	84	30	76.98	2.71

EVWNL • Notched Worksurface Left

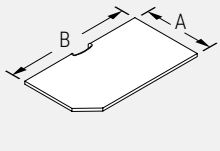

- When deepest end equals 24", the opposite depth is 18".
- When deepest end equals 30", the opposite depth is 24".
- The user edge is 6" shorter than the overall length.
- Please choose from DWT - Designer White, SIL - Silver or BLK - Black for scoop covers.

NOTE: EVWN

24	36
A	B
DEPTH	WIDTH

PRODUCT CODE	PRICE		SIZE/ INCHES			WEIGHT VOL	
	LP	HP	H	W	D	LBS	FT ³
EVWNL2424P	172	233	1	24	24	15.00	0.59
EVWNL2430P	182	240	1	30	24	19.00	0.72
EVWNL2436P	217	289	1	36	24	23.00	0.85
EVWNL2442P	252	339	1	42	24	27.00	0.98
EVWNL2448P	289	385	1	48	24	31.00	1.11
EVWNL2454P	327	433	1	54	24	35.00	1.23
EVWNL2460P	354	483	1	60	24	39.00	1.36
EVWNL2466P	392	528	1	66	24	43.00	1.49
EVWNL2472P	420	578	1	72	24	47.00	1.62
EVWNL3024P	174	239	1	24	30	19.00	0.74
EVWNL3030P	192	251	1	30	30	24.00	0.90
EVWNL3036P	229	289	1	36	30	29.00	1.06
EVWNL3042P	312	412	1	42	30	34.00	1.22
EVWNL3048P	327	433	1	48	30	39.00	1.38
EVWNL3054P	364	483	1	54	30	44.00	1.54
EVWNL3060P	391	528	1	60	30	49.00	1.69
EVWNL3066P	420	578	1	66	30	54.00	1.85
EVWNL3072P	451	626	1	72	30	59.00	2.01
EVWNL3078P	653	833	1	78	30	71.48	2.70
EVWNL3084P	833	850	1	84	30	76.98	2.92

EVWNR • Notched Worksurface Right

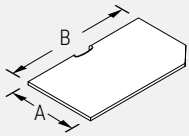

- When deepest end equals 24", the opposite depth is 18".
- When deepest end equals 30", the opposite depth is 24".
- The user edge is 6" shorter than the overall length.
- Please choose from DWT - Designer White, SIL - Silver or BLK - Black for scoop covers.

NOTE: EVWN

24	36
A	B
DEPTH	WIDTH

PRODUCT CODE	PRICE		SIZE/ INCHES			WEIGHT VOL	
	LP	HP	H	W	D	LBS	FT ³
EVWNR2424P	172	233	1	24	24	15.00	0.59
EVWNR2430P	182	240	1	30	24	19.00	0.72
EVWNR2436P	217	289	1	36	24	23.00	0.85
EVWNR2442P	252	339	1	42	24	27.00	0.98
EVWNR2448P	289	385	1	48	24	31.00	1.11
EVWNR2454P	327	433	1	54	24	35.00	1.23
EVWNR2460P	354	483	1	60	24	39.00	1.36
EVWNR2466P	392	528	1	66	24	43.00	1.49
EVWNR2472P	420	578	1	72	24	27.00	1.62
EVWNR3024P	174	239	1	24	24	19.00	0.74
EVWNR3030P	192	251	1	30	30	24.00	0.90
EVWNR3036P	229	289	1	36	30	29.00	1.06
EVWNR3042P	312	412	1	42	30	34.00	1.22
EVWNR3048P	327	433	1	48	30	39.00	1.38
EVWNR3054P	364	483	1	54	30	44.00	1.54
EVWNR3060P	391	528	1	60	30	49.00	1.69
EVWNR3066P	420	578	1	66	30	54.00	1.85
EVWNR3072P	451	626	1	72	30	59.00	2.01
EVWNR3078P	653	833	1	78	30	71.48	2.70
EVWNR3084P	833	850	1	84	30	76.98	2.92

EVWC4C • Corner Curved Worksurface For 45° Post

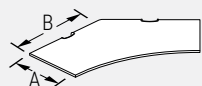

NOTE:
A= 18, 24, 30
B= 24, 30, 36, 42, 48

- "WG" at the end of the code indicates wood grain laminate on the diagonal.
- "WG" worksurface over 42" cannot be done on the diagonal.
- Support hardware must be ordered separately. See the listing in this section.
- Please choose from DWT - Designer White, SIL - Silver or BLK - Black for scoop covers.

PRODUCT CODE	PRICE		SIZE/ H	INCHES		WEIGHT VOL	
	LP	HP		W	D	LBS	FT ³
EVWC4C1824P	397	495	1	24	18	19.38	0.43
EVWC4C1830P	512	638	1	30	18	24.87	0.55
EVWC4C1836P	720	895	1	36	18	30.36	0.67
EVWC4C1842P	1166	1456	1	42	18	35.78	0.80
EVWC4C1848P	1358	1697	1	48	18	41.28	0.92
EVWC4C2424P	411	516	1	24	24	24.04	0.53
EVWC4C2430P	578	723	1	30	24	31.38	0.70
EVWC4C2436P	797	998	1	36	24	38.72	0.86
EVWC4C2442P	1166	1456	1	42	24	46.07	1.02
EVWC4C2448P	1527	1907	1	48	24	53.41	1.19
EVWC4C3024P	431	537	1	24	30	27.94	0.62
EVWC4C3030P	641	802	1	30	30	37.16	0.83
EVWC4C3036P	877	1094	1	36	30	46.38	1.03
EVWC4C3042P	1306	1638	1	42	30	55.60	1.24
EVWC4C3048P	1697	2121	1	48	30	64.82	1.44
EVWC4C1824WGP	595	743	1	24	18	19.38	0.43
EVWC4C1830WGP	768	957	1	30	18	24.87	0.55
EVWC4C1836WGP	1079	1343	1	36	18	30.36	0.67
EVWC4C1842WGP	1749	2184	1	42	18	35.78	0.80
EVWC4C2424WGP	617	774	1	24	24	24.04	0.53
EVWC4C2430WGP	867	1085	1	30	24	31.38	0.70
EVWC4C2436WGP	1197	1498	1	36	24	38.72	0.86
EVWC4C2442WGP	1749	2184	1	42	24	46.07	1.02
EVWC4C3024WGP	646	805	1	24	30	27.94	0.62
EVWC4C3030WGP	960	1203	1	30	30	37.16	0.83
EVWC4C3036WGP	1315	1640	1	36	30	46.38	1.03
EVWC4C3042WGP	1959	2456	1	42	30	55.60	1.24

EVWC4K • Keyboard Corner Worksurface For 45° Post



NOTE:
A= 18, 24, 30
B= 24, 30, 36, 42, 48

- "WG" at the end of the code indicates wood grain laminate on the diagonal.
- "WG" worksurface over 42" cannot be done on the diagonal.
- Support hardware must be ordered separately. See the listing in this section.
- Please choose from DWT - Designer White, SIL - Silver or BLK - Black for scoop covers.

PRODUCT CODE	PRICE		SIZE/ H	INCHES		WEIGHT VOL	
	LP	HP		W	D	LBS	FT ³
EVWC4K1824P	422	534	1	24	18	19.38	0.43
EVWC4K1830P	656	819	1	30	18	24.87	0.55
EVWC4K1836P	931	1168	1	36	18	30.36	0.67
EVWC4K1842P	1166	1456	1	42	18	35.78	0.80
EVWC4K1848P	1358	1697	1	48	18	41.28	0.92
EVWC4K2424P	509	636	1	24	24	24.04	0.53
EVWC4K2430P	762	955	1	30	24	31.38	0.70
EVWC4K2436P	1066	1332	1	36	24	38.72	0.86
EVWC4K2442P	1166	1456	1	42	24	46.07	1.02
EVWC4K2448P	1527	1907	1	48	24	53.41	1.19
EVWC4K3024P	593	744	1	24	30	27.94	0.62
EVWC4K3030P	942	1090	1	30	30	37.16	0.83
EVWC4K3036P	1066	1332	1	36	30	46.38	1.03
EVWC4K3042P	1306	1638	1	42	30	55.60	1.24
EVWC4K3048P	1697	2121	1	48	30	64.82	1.44
EVWC4K1824WGP	633	800	1	24	18	19.38	0.43
EVWC4K1830WGP	984	1229	1	30	18	24.87	0.55
EVWC4K1836WGP	1397	1752	1	36	18	30.36	0.67
EVWC4K1842WGP	1749	2184	1	42	18	35.78	0.80
EVWC4K2424WGP	763	954	1	24	24	24.04	0.53
EVWC4K2430WGP	1143	1433	1	30	24	31.38	0.70
EVWC4K2436WGP	1600	1997	1	36	24	38.72	0.86
EVWC4K2442WGP	1749	2184	1	42	24	46.07	1.02
EVWC4K3024WGP	891	1114	1	24	30	27.94	0.62
EVWC4K3030WGP	1414	1635	1	30	30	37.16	0.83
EVWC4K3036WGP	1600	1997	1	36	30	46.38	1.03
EVWC4K3042WGP	1959	2456	1	42	30	55.60	1.24

EVW4T • Corner Transaction Surface For 45° Post

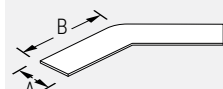

- Support hardware must be ordered separately. See the listing in this section.
- For use with laminate end and middle panels.

NOTE:
A= 15
B= 24, 30, 36, 42, 48

PRODUCT CODE	PRICE		SIZE/ H	INCHES		WEIGHT VOL	
	LP	HP		W	D	LBS	FT ³
EVW4T1524	582	726	1	24	15	19.14	0.43
EVW4T1530	726	909	1	30	15	23.78	0.53
EVW4T1536	1018	1272	1	36	15	28.39	0.63
EVW4T1542	1358	1697	1	42	15	32.99	0.73
EVW4T1548	1456	1817	1	48	15	37.58	0.84

EVWC6C • Corner Curved Worksurface For 60° Post

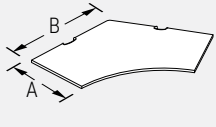

- "WG" at the end of the code indicates wood grain laminate on the diagonal.
- "WG" worksurface over 42" cannot be done on the diagonal.
- Support hardware must be ordered separately. See the listing in this section.
- Please choose from DWT - Designer White, SIL - Silver or BLK - Black for scoop covers.

NOTE:

A= 18, 24, 30

B= 24, 30, 36, 42, 48

PRODUCT CODE	PRICE		SIZE/ INCHES			WEIGHT VOL	
	LP	HP	H	W	D	LBS	FT ³
EVWC6C1824P	341	425	1	24	18	17.76	0.39
EVWC6C1830P	465	581	1	30	18	23.26	0.52
EVWC6C1836P	661	829	1	36	18	28.75	0.64
EVWC6C1842P	975	1073	1	42	18	34.17	0.76
EVWC6C1848P	1330	1464	1	48	18	39.66	0.88
EVWC6C2424P	354	446	1	24	24	21.25	0.47
EVWC6C2430P	508	631	1	30	24	28.59	0.64
EVWC6C2436P	712	892	1	36	24	35.94	0.80
EVWC6C2442P	1223	1340	1	42	24	43.28	0.96
EVWC6C2448P	1330	1464	1	48	24	50.63	1.13
EVWC6C3024P	372	465	1	24	30	23.72	0.53
EVWC6C3030P	544	683	1	30	30	32.94	0.73
EVWC6C3036P	762	954	1	36	30	42.16	0.94
EVWC6C3042P	1223	1340	1	42	30	51.38	1.14
EVWC6C3048P	1330	1464	1	48	30	60.60	1.35
EVWC6C1824WGP	512	638	1	24	18	17.76	0.39
EVWC6C1830WGP	697	871	1	30	18	23.26	0.52
EVWC6C1836WGP	993	1244	1	36	18	28.75	0.64
EVWC6C1842WGP	1464	1610	1	42	18	34.17	0.76
EVWC6C2424WGP	531	670	1	30	24	28.59	0.64
EVWC6C2430WGP	761	947	1	36	24	35.94	0.80
EVWC6C2436WGP	1067	1338	1	42	24	43.28	0.96
EVWC6C2442WGP	1833	2011	1	48	24	50.63	1.13
EVWC6C3024WGP	557	697	1	24	30	23.72	0.53
EVWC6C3030WGP	816	1025	1	30	30	32.94	0.73
EVWC6C3036WGP	1143	1431	1	36	30	42.16	0.94
EVWC6C3042WGP	1833	2011	1	42	30	51.38	1.14

EVWC6K • Keyboard Corner Worksurface For 60° Post

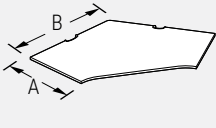

- "WG" at the end of the code indicates wood grain laminate on the diagonal.
- "WG" worksurface over 42" cannot be done on the diagonal.
- Support hardware must be ordered separately. See the listing in this section.
- Please choose from DWT - Designer White, SIL - Silver or BLK - Black for scoop covers.

NOTE:

A= 18, 24, 30

B= 24, 30, 36, 42, 48

PRODUCT CODE	PRICE		SIZE/ INCHES			WEIGHT VOL	
	LP	HP	H	W	D	LBS	FT ³
EVWC6K1824P	333	367	1	24	18	17.76	0.39
EVWC6K1830P	535	586	1	30	18	23.26	0.52
EVWC6K1836P	800	879	1	36	18	28.75	0.64
EVWC6K1842P	975	1073	1	42	18	34.17	0.76
EVWC6K1848P	1330	1464	1	48	18	39.66	0.88
EVWC6K2430P	709	783	1	30	24	28.59	0.64
EVWC6K2436P	800	879	1	36	24	35.94	0.80
EVWC6K2442P	975	1073	1	42	24	43.28	0.96
EVWC6K2448P	1330	1464	1	48	24	50.63	1.13
EVWC6K3030P	709	783	1	30	30	32.94	0.73
EVWC6K3036P	796	1029	1	36	30	42.16	0.94
EVWC6K3042P	1089	1411	1	42	30	51.38	1.14
EVWC6K3048P	1323	1719	1	48	30	60.60	1.35
EVWC6K1824WGP	500	551	1	24	18	17.76	0.39
EVWC6K1830WGP	802	879	1	30	18	23.26	0.52
EVWC6K1836WGP	1200	1317	1	36	18	28.75	0.64
EVWC6K1842WGP	1464	1610	1	42	18	34.17	0.76
EVWC6K2430WGP	1062	1174	1	30	24	28.59	0.64
EVWC6K2436WGP	1200	1317	1	36	24	35.94	0.80
EVWC6K2442WGP	1464	1610	1	42	24	43.28	0.96
EVWC6K3030WGP	1062	1174	1	30	30	32.94	0.73
EVWC6K3036WGP	1195	1543	1	36	30	42.16	0.94
EVWC6K3042WGP	1634	2116	1	42	30	51.38	1.14

EVW6T • Corner Transaction Surface For 60° Post

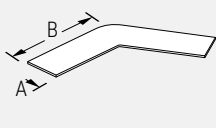

- Support hardware must be ordered separately. See the listing in this section.
- For use with laminate end and middle panels.

NOTE:

A= 15

B= 24, 30, 36, 42, 48

PRODUCT CODE	PRICE		SIZE/ INCHES			WEIGHT VOL	
	LP	HP	H	W	D	LBS	FT ³
EVW6T1518	340	435	1	18	15	14.53	0.32
EVW6T1524	536	691	1	24	15	19.17	0.43
EVW6T1530	694	898	1	30	15	23.78	0.53
EVW6T1536	969	1257	1	36	15	28.39	0.63
EVW6T1542	1055	1366	1	42	15	32.97	0.73
EVW6T1548	1378	1785	1	48	15	34.17	0.76

EVWCC • Corner Curved Worksurface

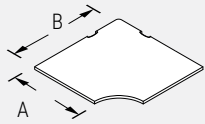

- "WG" at the end of the code indicates wood grain laminate on the diagonal.
- "WG" worksurface over 42" cannot be done on the diagonal.
- Please choose from DWT - Designer White, SIL - Silver or BLK - Black for scoop covers.

NOTE: EVWCC

18	36
A	B
DEPTH	WIDTH

PRODUCT CODE	PRICE		SIZE/ INCHES	WEIGHT VOL	
	LP	HP		LBS	FT ³
EVWCC3618P	397	495	1 36 18	24.00	1.27
EVWCC3624P	439	548	1 36 24	30.00	1.47
EVWCC4224P	591	736	1 42 24	47.00	1.70
EVWCC4230P	607	759	1 42 30	53.00	1.98
EVWCC4824P	688	857	1 48 24	53.00	2.67
EVWCC4830P	688	857	1 48 30	55.00	2.67
EVWCC3618WGP	441	567	1 36 18	19.80	0.75
EVWCC3624WGP	485	625	1 36 24	30.00	1.47
EVWCC4224WGP	657	845	1 42 24	47.00	1.70
EVWCC4230WGP	712	916	1 42 30	53.00	1.96

EVWCKK • Corner Worksurface with Curved Keyboard Support

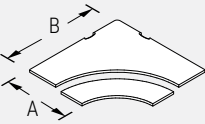

- Keyboard mechanism is included.
- Must be supported with two 24" Cantilevers and 2 Flat Brackets (ordered separately).
- "WG" worksurface over 42" cannot be done on the diagonal.
- "WG" at the end of the code indicates wood grain laminate on the diagonal.
- Keyboard Support is 11" deep, adjusts 6" above and 6" below surface with a positive/negative tilt (+15° to -15°).
- Please choose from DWT - Designer White, SIL - Silver or BLK - Black for scoop covers.

NOTE: EVWCC

24	42
A	B
DEPTH	WIDTH

PRODUCT CODE	PRICE		SIZE/ INCHES	WEIGHT VOL	
	LP	HP		LBS	FT ³
EVWCKK4224P	1238	1374	1 42 24	38.00	0.95
EVWCKK4230P	1315	1466	1 42 30	42.00	1.15
EVWCKK4824P	1389	1560	1 48 24	48.00	1.55
EVWCKK4830P	1424	1605	1 48 30	50.00	1.65
EVWCKK4224WGP	1329	1502	1 42 24	38.00	0.95
EVWCKK4230WGP	1422	1606	1 42 30	42.00	1.15

EVWCK • Corner Keyboard Worksurface

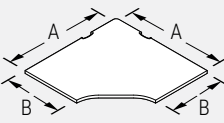

- "WG" at the end of the code indicates wood grain laminate on the diagonal.
- "WG" worksurface over 42" cannot be done on the diagonal.
- Please choose from DWT - Designer White, SIL - Silver or BLK - Black for scoop covers.

NOTE: EVWC

24	36
A	B
DEPTH	WIDTH

PRODUCT CODE	PRICE		SIZE/ INCHES	WEIGHT VOL	
	LP	HP		LBS	FT ³
EVWCK3618P	388	484	1 36 18	39.59	1.50
EVWCK3624P	430	536	1 36 24	39.59	1.50
EVWCK4224P	570	714	1 42 24	53.89	2.04
EVWCK4230P	589	734	1 42 30	53.89	2.04
EVWCK4824P	660	827	1 48 24	70.39	2.67
EVWCK4830P	660	827	1 48 30	70.39	2.67
EVWCK3618WGP	441	550	1 36 18	34.00	1.27
EVWCK3624WGP	484	605	1 36 24	45.00	1.69
EVWCK4224WGP	655	817	1 42 24	47.00	1.70
EVWCK4230WGP	707	884	1 42 30	58.00	2.12

EVWCF • Five Sided Worksurface

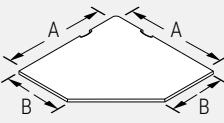

- "WG" at the end of the code indicates wood grain laminate on the diagonal.
- "WG" worksurface over 42" cannot be done on the diagonal.
- Please choose from DWT - Designer White, SIL - Silver or BLK - Black for scoop covers.

NOTE: EVWC

24	36
A	B
DEPTH	WIDTH

PRODUCT CODE	PRICE		SIZE/ INCHES	WEIGHT VOL	
	LP	HP		LBS	FT ³
EVWCF3012P	259	320	1 30 24	11.00	0.42
EVWCF3612P	341	425	1 36 24	13.20	0.50
EVWCF3618P	341	425	1 36 18	19.80	0.75
EVWCF3624P	354	446	1 36 24	26.40	1.00
EVWCF4224P	503	627	1 42 24	30.79	1.17
EVWCF4230P	517	652	1 42 30	38.49	1.46
EVWCF4824P	567	707	1 48 24	35.19	1.33
EVWCF4830P	596	747	1 48 30	43.99	1.67
EVWCF3618WGP	441	567	1 36 18	34.00	1.27
EVWCF3624WGP	485	625	1 36 24	45.00	1.69
EVWCF4224WGP	657	845	1 42 24	47.00	1.70
EVWCF4230WGP	712	916	1 42 30	58.75	2.12

EVWKKR • Angle Front Edge Worksurface

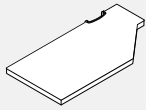

- To be used with EVWCF3012SCP & EVWCF3612SCP Corner Worksurface
- Creates efficient, compact keyboard corner workstation
- For use with flat screen monitors
- Please choose from DWT - Designer White, SIL - Silver or BLK - Black for scoop covers.

PRODUCT CODE	PRICE		SIZE/ INCHES			WEIGHT VOL	
	LP	HP	H	W	D	LBS	FT ³
EVWKKR2448P	251	313	1	48	24	35.00	1.11
EVWKKL2448P	251	313	1	48	24	35.00	1.11
EVWKKR2442P	219	275	1	42	24	31.00	0.98
EVWKKL2442P	219	275	1	42	24	31.00	0.98
EVWKKR2436P	190	236	1	36	24	26.00	0.85
EVWKKL2436P	190	236	1	36	24	26.00	0.85

EVWCC • Non-Symmetrical Corner Curved Worksurface

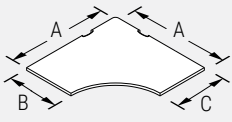

- Please specify starting at the first "A" on the left side and then continuing clockwise.
- "WG" worksurface over 42" cannot be done on the diagonal.
- Please choose from DWT - Designer White, SIL - Silver or BLK - Black for scoop covers.

NOTE: EVWCC

36	36	18	24
A	A	B	C
WIDTH	WIDTH	DEPTH	DEPTH

PRODUCT CODE	PRICE		SIZE/ INCHES			WEIGHT VOL	
	LP	HP	W(A)	D(B)	D(C)	LBS	FT ³
EVWCC36361824P	439	665	36	18	24	30.00	1.47
EVWCC36362418P	439	665	36	24	18	30.00	1.47
EVWCC36362430P	516	699	36	24	30	30.00	1.47
EVWCC36363024P	516	699	36	30	24	30.00	1.47
EVWCC42421824P	591	736	42	18	24	53.89	2.04
EVWCC42422418P	591	736	42	24	18	53.89	2.04
EVWCC42422430P	607	759	42	24	30	53.89	2.04
EVWCC42423024P	607	759	42	30	24	53.89	2.04
EVWCC48482430P	688	857	48	24	30	70.38	2.66
EVWCC48483024P	688	857	48	30	24	70.38	2.66
EVWCC36361824WGP	548	697	36	18	24	30.00	1.47
EVWCC36362418WGP	548	697	36	24	18	30.00	1.47
EVWCC36362430WGP	579	736	36	24	30	30.00	1.47
EVWCC36363024WGP	579	736	36	30	24	30.00	1.47
EVWCC42421824WGP	666	865	42	18	24	53.89	2.04
EVWCC42422418WGP	666	865	42	24	18	53.89	2.04
EVWCC42422430WGP	722	928	42	24	30	53.89	2.04
EVWCC42423024WGP	722	928	42	30	24	53.89	2.04

EVWCK • Non-Symmetrical Corner Keyboard Worksurface

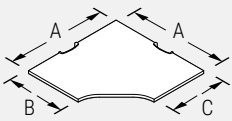

- Please specify starting at the first "A" on the left side and then continuing clockwise
- "WG" worksurface over 42" cannot be done on the diagonal.
- Please choose from DWT - Designer White, SIL - Silver or BLK - Black for scoop covers.

NOTE: EVWCC

36	36	18	24
A	A	B	C
WIDTH	WIDTH	DEPTH	DEPTH

PRODUCT CODE	PRICE		SIZE/INCHES			WEIGHT VOL	
	LP	HP	W(A)	D(B)	D(C)	LBS	FT ³
EVWCK36361824P	450	683	36	18	24	39.59	1.50
EVWCK36362418P	450	683	36	24	24	39.59	1.50
EVWCK42421824P	600	749	42	18	24	53.89	2.04
EVWCK42422418P	600	749	42	24	18	53.89	2.04
EVWCK42422430P	619	773	42	24	30	53.89	2.04
EVWCK42423024P	619	773	42	30	24	53.89	2.04
EVWCK48482430P	694	868	48	24	30	70.38	2.66
EVWCK48483024P	694	868	48	30	24	70.38	2.66
EVWCK36361824WGP	537	755	36	18	24	39.59	1.50
EVWCK36362418WGP	537	755	36	24	24	39.59	1.50
EVWCK42421824WGP	666	865	42	18	24	53.89	2.04
EVWCK42422418WGP	666	865	42	24	18	53.89	2.04
EVWCK42422430WGP	733	952	42	24	30	53.89	2.04
EVWCK42423024WGP	733	952	42	30	24	53.89	2.04

EVWCF • Non-Symmetrical Five Sided Worksurface

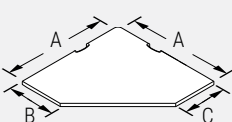

- Please specify starting at the first "A" on the left side and then continuing clockwise.
- "WG" worksurface over 42" cannot be done on the diagonal.
- Please choose from DWT - Designer White, SIL - Silver or BLK - Black for scoop covers.

NOTE: EVWCC

36	36	18	24
A	A	B	C
WIDTH	WIDTH	DEPTH	DEPTH

PRODUCT CODE	PRICE		SIZE/INCHES			WEIGHT VOL	
	LP	HP	W(A)	D(B)	D(C)	LBS	FT ³
EVWCF36361824P	418	638	36	18	24	30.00	1.47
EVWCF36362418P	418	638	36	24	18	30.00	1.47
EVWCF36362430P	439	665	36	24	30	30.00	1.47
EVWCF36363024P	439	665	36	30	24	30.00	1.47
EVWCF42421824P	503	692	42	18	24	53.89	2.04
EVWCF42422418P	503	692	42	24	18	53.89	2.04
EVWCF42422430P	577	754	42	24	30	53.89	2.04
EVWCF42423024P	577	754	42	30	24	53.89	2.04
EVWCF48482430P	629	837	48	24	30	70.38	2.66
EVWCF48483024P	629	837	48	30	24	70.38	2.66
EVWCF36361824WGP	557	723	36	18	24	30.00	1.47
EVWCF36362418WGP	557	723	36	24	18	30.00	1.47
EVWCF36362430WGP	592	780	36	24	30	30.00	1.47
EVWCF36363024WGP	592	780	36	30	24	30.00	1.47
EVWCF42421824WGP	602	779	42	18	24	53.89	2.04
EVWCF42422418WGP	602	779	42	24	18	53.89	2.04
EVWCF42422430WGP	629	817	42	24	30	53.89	2.04
EVWCF42423024WGP	629	817	42	30	24	53.89	2.04

EVWL • “L” Worksurface

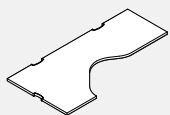

- There are three cable scoops on this worksurface.
- Wood grain laminate not available on the diagonal.
- Must be specified either left or right.
- Please choose from DWT - Designer White, SIL - Silver or BLK - Black for scoop covers.

PRODUCT CODE	PRICE		SIZE/INCHES			WEIGHT VOL	
	LP	HP	H	W	D	LBS	FT ³
EVWLL2472P	737	922	1	72	24	73.00	2.70
EVWLR2472P	737	922	1	72	24	73.00	2.70

EVWBTL • Transition Worksurface

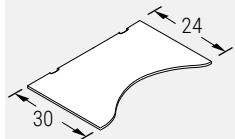

Left Hand Shown

- Support hardware must be ordered separately. See the listing in this section of the price list.
- Opposing side of 30" deep Transition Worksurface has depth of 24".
- Scoops located on back edge only.
- Must be specified as right or left handed.
- Please choose from DWT - Designer White, SIL - Silver or BLK - Black for scoop covers.

PRODUCT CODE	PRICE		SIZE/INCHES			WEIGHT VOL	
	LP	HP	W	D	D2	LBS	FT ³
EVWBTL3060P	561	698	60	30	24	54.99	2.08
EVWBTL3066P	619	770	66	30	24	60.49	2.29
EVWBTL3072P	671	842	72	30	24	65.99	2.50
EVWBTR3060P	561	698	60	30	24	54.99	2.08
EVWBTR3066P	614	770	66	30	24	60.49	2.29
EVWBTR3072P	671	842	72	30	24	60.49	2.29

EVWBTL • Transition Worksurface

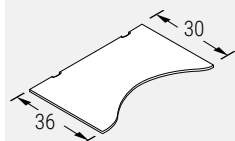

Left Hand Shown

- Support hardware must be ordered separately. See the listing in this section of the price list.
- Opposing side of 36" deep Transition Worksurface has depth of 30".
- Scoops located on back edge only.
- Must be specified as right or left handed.
- Please choose from DWT - Designer White, SIL - Silver or BLK - Black for scoop covers.

PRODUCT CODE	PRICE		SIZE/ INCHES			WEIGHT VOL	
	LP	HP	W	D	D2	LBS	FT ³
EVWBTL3660P	671	857	60	36	30	65.99	2.50
EVWBTL3666P	737	925	66	36	30	72.59	2.75
EVWBTL3672P	805	1007	72	36	30	79.19	3.00
EVWBTR3660P	671	842	60	36	30	65.99	2.50
EVWBTR3666P	737	925	66	36	30	72.59	2.75
EVWBTR3672P	805	1007	72	36	30	79.19	3.00

EVWCEL • Extended Curved Corner - Left

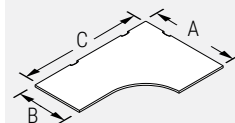

- For 48" wide ("C" dimension) worksurfaces, there are two cable scoops, all others have three.
- Wood grain laminate not available on the diagonal.
- Please choose from DWT - Designer White, SIL - Silver or BLK - Black for scoop covers.

NOTE: EVWCE

36	24	72
A	B	C
DEPTH	DEPTH	WIDTH

PRODUCT CODE	PRICE		SIZE/ INCHES			WEIGHT VOL	
	LP	HP	A	B	C	LBS	FT ³
EVWCEL362448P	600	744	36	24	48	43.92	1.25
EVWCEL362460P	655	816	36	24	60	52.79	1.50
EVWCEL362466P	721	895	36	24	66	57.18	1.62
EVWCEL362472P	796	994	36	24	72	61.58	1.75
EVWCEL362478P	850	1062	36	24	78	65.98	1.87
EVWCEL362484P	917	1143	36	24	84	70.38	2.00
EVWCEL422460P	688	857	42	24	60	57.18	1.63
EVWCEL422466P	758	947	42	24	66	61.58	1.57
EVWCEL422472P	835	1045	42	24	72	65.98	1.87
EVWCEL422478P	893	1117	42	24	78	70.38	2.00
EVWCEL422484P	962	1201	42	24	84	74.78	2.00
EVWCEL423060P	775	970	42	30	60	63.78	1.82
EVWCEL423066P	850	1062	42	30	66	69.28	1.96
EVWCEL423072P	929	1160	42	30	72	74.78	2.12
EVWCEL423078P	996	1243	42	30	78	80.28	2.28
EVWCEL423084P	1062	1326	42	30	84	85.78	2.43
EVWCEL482460P	786	984	48	24	60	65.18	1.90
EVWCEL482466P	874	1092	48	24	66	96.78	3.66
EVWCEL482472P	956	1197	48	24	72	76.18	1.95
EVWCEL482478P	1021	1273	48	24	78	74.78	1.20
EVWCEL482484P	1083	1352	48	24	84	123.17	4.66
EVWCEL483060P	874	1092	48	30	60	68.18	1.93
EVWCEL483066P	956	1197	48	30	66	73.68	2.09
EVWCEL483072P	1021	1273	48	30	72	79.18	2.25
EVWCEL483078P	1083	1352	48	30	78	84.68	2.40
EVWCEL483084P	1158	1450	48	30	84	90.18	2.56

EVWCER • Extended Curved Corner - Right

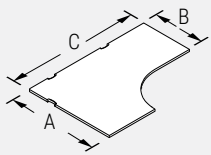

- For 48" wide ("C" dimension) worksurfaces, there are two cable scoops, all others have three finishes.
- Wood grain laminate not available on the diagonal.
- Please choose from DWT - Designer White, SIL - Silver or BLK - Black for scoop covers.

NOTE: EVWCE

36	24	72
A	B	C
DEPTH	DEPTH	WIDTH

PRODUCT CODE	PRICE		SIZE/ INCHES			WEIGHT VOL	
	LP	HP	A	B	C	LBS	FT ³
EVWCER362448P	600	744	36	24	48	43.92	1.25
EVWCER362460P	655	816	36	24	60	52.79	1.50
EVWCER362466P	721	895	36	24	66	57.18	1.62
EVWCER362472P	796	994	36	24	72	61.58	1.75
EVWCER362478P	850	1062	36	24	78	65.98	1.87
EVWCER362484P	917	1143	36	24	84	70.38	2.00
EVWCER422460P	688	857	42	24	60	57.18	1.63
EVWCER422466P	758	947	42	24	66	61.58	1.57
EVWCER422472P	835	1045	42	24	72	65.98	1.87
EVWCER422478P	893	1117	42	24	78	70.38	2.00
EVWCER422484P	962	1201	42	24	84	74.78	2.00
EVWCER423060P	775	970	42	30	60	63.78	1.82
EVWCER423066P	850	1062	42	30	66	69.28	1.96
EVWCER423072P	929	1160	42	30	72	74.78	2.12
EVWCER423078P	996	1243	42	30	78	80.28	2.28
EVWCER423084P	1062	1326	42	30	84	85.78	2.43
EVWCER482460P	786	984	48	24	60	65.18	1.90
EVWCER482466P	874	1092	48	24	66	96.78	3.66
EVWCER482472P	956	1197	48	24	72	76.18	1.95
EVWCER482478P	1021	1273	48	24	78	74.78	1.20
EVWCER482484P	1083	1352	48	24	84	123.17	4.66
EVWCER483060P	874	1092	48	30	60	68.18	1.93
EVWCER483066P	956	1197	48	30	66	73.68	2.09
EVWCER483072P	1021	1273	48	30	72	79.18	2.25
EVWCER483078P	1083	1352	48	30	78	84.68	2.40
EVWCER483084P	1158	1450	48	30	84	90.18	2.56

EVWH • Hatchet Worksurface

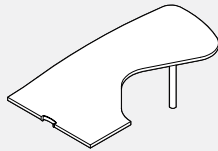

- Cable scoop is in the middle of the 36" wide edge.
- Wood grain laminate not available on the diagonal.
- Must be specified either left or right.
- Includes monoleg.
- Please choose from DWT - Designer White, SIL - Silver or BLK - Black for scoop covers.

Right Hand Shown

PRODUCT CODE	PRICE		SIZE/ INCHES			WEIGHT VOL	
	LP	HP	H	W	D	LBS	FT ³
EVWHL3672P	1079	1299	1	72	30	73.00	2.70
EVWHR3672P	1079	1299	1	72	30	73.00	2.70

EVWSH • Hatchet Worksurface - Straight Front

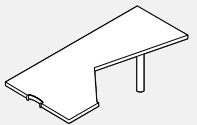

- Cable scoop is in the middle of the 36" wide edge.
- Wood grain laminate not available on the diagonal.
- Support hardware must be ordered separately.
- Must be specified either left or right.
- Includes monoleg.
- Please choose from DWT - Designer White, SIL - Silver or BLK - Black for scoop covers.

Right Hand Shown

PRODUCT CODE	PRICE		SIZE/ INCHES			WEIGHT VOL	
	LP	HP	H	W	D	LBS	FT ³
EVWSHL3672P	1027	1236	1	72	30	73.00	2.70
EVWSHR3672P	1027	1236	1	72	30	73.00	2.70

EVWD • "D" Worksurface

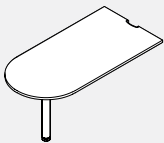

- Cable scoop is at the centre of the end.
- Includes monoleg.
- Please choose from DWT - Designer White, SIL - Silver or BLK - Black for scoop covers.

PRODUCT CODE	PRICE		SIZE/ INCHES			WEIGHT VOL	
	LP	HP	H	W	D	LBS	FT ³
EVWD2442P	569	659	1	42	24	28.00	0.98
EVWD2448P	593	693	1	48	24	32.00	1.11
EVWD2460P	623	725	1	60	24	40.00	1.36
EVWD2472P	661	779	1	72	24	48.00	1.61
EVWD3048P	596	695	1	48	30	39.00	1.37
EVWD3060P	665	780	1	60	30	49.00	1.69
EVWD3072P	731	864	1	72	30	59.00	2.01

EVWPT • “P” Top Worksurface

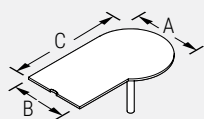

Left Hand Shown

- Cable scoop is at the center of the panel with edge.
- Must be specified either left or right.
- Includes monoleg.
- Please choose from DWT - Designer White, SIL - Silver or BLK - Black for scoop covers.

NOTE: EVWCE

24	60	30
A	B	C
DEPTH	DEPTH	WIDTH

PRODUCT CODE	PRICE		SIZE/ INCHES			WEIGHT VOL	
	LP	HP	H	W	D	LBS	FT ³
EVWPTL245430P	773	938	1	54	24	39.50	1.50
EVWPTL246030P	829	992	1	60	24	54.99	2.08
EVWPTL246630P	846	1074	1	66	24	60.48	2.29
EVWPTL247230P	894	1121	1	72	24	65.98	2.50
EVWPTL306036P	916	1140	1	60	30	65.98	2.50
EVWPTL306636P	992	1182	1	66	30	72.58	2.75
EVWPTL307236P	1034	1236	1	72	30	79.00	2.41
EVWPTR245430P	773	938	1	54	24	39.50	1.50
EVWPTR246030P	829	992	1	60	24	54.99	2.08
EVWPTR246630P	846	1074	1	66	24	60.48	2.29
EVWPTR247230P	894	1121	1	72	24	65.98	2.50
EVWPTR306036P	916	1140	1	60	30	65.98	2.50
EVWPTR306636P	992	1182	1	66	30	72.58	2.75
EVWPTR307236P	1034	1236	1	72	30	79.00	2.41

EVWW • Wedge Worksurface

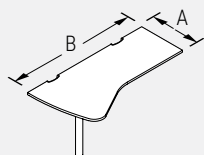

Left Hand Shown

- Two cable scoops on the back side of worksurface.
- Must be specified either left or right.
- Includes monoleg.
- Conference end is 10" wider than "A".
- Please choose from DWT - Designer White, SIL - Silver or BLK - Black for scoop covers.

NOTE: EVWC

18	48
A	B
DEPTH	WIDTH

PRODUCT CODE	PRICE		SIZE/ INCHES			WEIGHT VOL	
	LP	HP	H	W	D	LBS	FT ³
EVWWL2460P	653	761	1	60	24	51.99	1.81
EVWWL2466P	691	812	1	66	24	56.39	1.98
EVWWL2472P	727	863	1	72	24	60.79	2.15
EVWWL2478P	817	1022	1	78	24	65.18	2.31
EVWWL2484P	829	1035	1	84	24	69.58	2.48
EVWWL3060P	752	886	1	60	30	62.99	2.23
EVWWL3066P	800	951	1	66	30	68.44	2.44
EVWWL3072P	851	1012	1	72	30	73.98	2.65
EVWWR2460P	653	761	1	60	24	51.99	1.81
EVWWR2466P	691	812	1	66	24	56.39	1.98
EVWWR2472P	727	863	1	72	24	60.79	2.15
EVWWR2478P	817	1022	1	78	24	65.18	2.31
EVWWR2484P	829	1035	1	84	24	69.58	2.48
EVWWR3060P	752	886	1	60	30	62.99	2.23
EVWWR3066P	800	951	1	66	30	68.44	2.44
EVWWR3072P	851	1012	1	72	30	73.98	2.65

EVWPL • Piano Top Worksurface Left

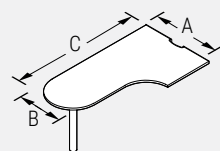

Left Hand Shown

- Cable scoop is at the center of the panel with edge.
- Must be specified either left or right.
- Includes monoleg.
- Works with EVWMP modesty.
- Please choose from DWT - Designer White, SIL - Silver or BLK - Black for scoop covers.

NOTE: EVWP

36	18	48
A	B	C
DEPTH	DEPTH	WIDTH

PRODUCT CODE	PRICE		SIZE/ INCHES			WEIGHT VOL	
	LP	HP	H	W	D	LBS	FT ³
EVWPL361848P	727	863	1	48	36	52.79	2.00
EVWPL361854P	773	916	1	54	36	59.39	2.25
EVWPL361860P	813	969	1	60	36	65.99	2.50
EVWPL361866P	857	1022	1	66	36	72.59	2.75
EVWPL361872P	896	1072	1	72	36	79.18	3.00
EVWPL362448P	736	868	1	48	24	52.79	2.75
EVWPL362454P	778	920	1	54	24	59.39	2.25
EVWPL362460P	823	973	1	60	24	65.58	1.68
EVWPL362466P	863	1026	1	66	24	73.00	2.23
EVWPL362472P	903	1078	1	72	24	79.18	3.00
EVWPL422454P	833	992	1	54	42	69.29	2.63
EVWPL422460P	883	1052	1	60	42	75.58	1.88
EVWPL422466P	930	1112	1	66	42	85.68	3.21
EVWPL422472P	975	1170	1	72	42	92.38	3.51
EVWPL423060P	897	1073	1	60	42	76.99	2.92
EVWPL423066P	952	1139	1	66	42	84.68	3.21
EVWPL423072P	1000	1199	1	72	42	92.38	3.50
EVWPL482460P	1001	1201	1	60	48	87.98	3.33
EVWPL482466P	1062	1275	1	66	48	87.98	3.33
EVWPL482472P	1121	1351	1	72	48	105.58	4.00
EVWPL483066P	1065	1284	1	66	48	96.78	3.66
EVWPL483072P	1125	1355	1	72	48	105.58	4.00

EVWPR • Piano Top Worksurface Right

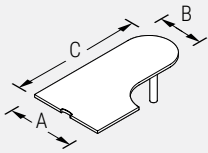

Right Hand Shown

- Cable scoop is at the center of the panel with edge.
- Must be specified either left or right.
- Includes monoleg.
- Works with EVWMP modesty.
- Please choose from DWT - Designer White, SIL - Silver or BLK - Black for scoop covers.

NOTE: EVWP

36	18	48
A	B	C
DEPTH	DEPTH	WIDTH

PRODUCT CODE	PRICE		SIZE/ INCHES			WEIGHT LBS	VOL FT ³
	LP	HP	H	W	D		
EVWPR361848P	727	863	1	48	36	52.79	2.00
EVWPR361854P	773	916	1	54	36	59.39	2.25
EVWPR361860P	813	969	1	60	36	65.99	2.50
EVWPR361866P	857	1022	1	66	36	72.59	2.75
EVWPR361872P	896	1072	1	72	36	79.18	3.00
EVWPR362448P	736	868	1	48	24	52.79	2.75
EVWPR362454P	778	920	1	54	24	59.39	2.25
EVWPR362460P	823	973	1	60	24	65.58	1.68
EVWPR362466P	863	1026	1	66	24	73.00	2.23
EVWPR362472P	903	1078	1	72	24	79.18	3.00
EVWPR422454P	833	992	1	54	42	69.29	2.63
EVWPR422460P	883	1052	1	60	42	75.58	1.88
EVWPR422466P	930	1112	1	66	42	85.68	3.21
EVWPR422472P	975	1170	1	72	42	92.38	2.27
EVWPR423060P	897	1073	1	60	42	76.99	2.92
EVWPR423066P	952	1139	1	66	42	84.68	3.21
EVWPR423072P	1000	1199	1	72	42	92.38	3.50
EVWPR482460P	1001	1201	1	60	48	87.98	2.25
EVWPR482466P	1062	1275	1	66	48	78.00	3.66
EVWPR482472P	1121	1351	1	72	48	105.58	4.00
EVWPR483066P	1065	1284	1	66	48	96.78	3.66
EVWPR483072P	1125	1355	1	72	48	105.58	4.00

EVWQR/L • Quarter Round Panel Worksurface

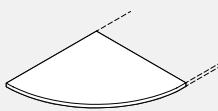

Left Hand Shown

- The worksurface edge running along the panel face is a slightly different length than that of the worksurface end, causing the surface to be handed.
- The user edge abutting the adjacent worksurface runs straight for 3" before starting to curve.

PRODUCT CODE	PRICE		SIZE/ INCHES			WEIGHT LBS	VOL FT ³
	LP	HP	H	W	D		
EVWQRL1818	139	174	1	18	18	9	0.30
EVWQRL2424	200	247	1	24	24	16	0.52
EVWQRL3030	259	320	1	30	30	25	0.81
EVWQRR1818	139	174	1	18	18	9	0.30
EVWQRR2424	200	247	1	24	24	16	0.52
EVWQRR3030	259	320	1	30	30	25	0.81

EVWQRC • Quarter Round Panel Corner Worksurface



- Wraps around a 90° corner post.
- Putting the adjacent worksurface runs straight for 3" before starting to curve.

PRODUCT CODE	PRICE		SIZE/ INCHES			WEIGHT LBS	VOL FT ³
	LP	HP	H	W	D		
EVWQRC1818	162	202	1	21	21	12.00	0.38
EVWQRC2424	235	293	1	27	27	17.00	0.58
EVWQRC3030	289	364	1	33	33	25.50	0.86

EVWMP • Worksurface Modesty Panel

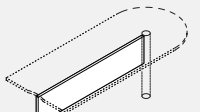

- Modesty panel fastens to the worksurface and Monoleg to provide additional privacy and support.
- Made of cold rolled steel and is epoxy powder coated.
- For "D", Hatchet and Piano Top Worksurfaces only (ordered separately).

PRODUCT CODE	PRICE		SIZE/ INCHES			WEIGHT LBS	VOL FT ³
	LP	HP	H	W	D		
EVWMP1242	134		13	26	1	4.00	0.22
EVWMP1248	151		13	32	1	5.00	0.25
EVWMP1260	174		13	44	1	6.00	0.30
EVWMP1272	225		13	56	1	8.00	2.00

EVWR • Radius Worksurface

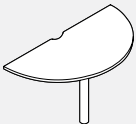

- Rounded worksurface for conferencing provides a radius corner from a worksurface to worksurface.
- 18" and 24" come with one monoleg and 30" comes with two monolegs.
- Radius cut out on the straight edge allows space for trims.
- Please choose from DWT - Designer White, SIL - Silver or BLK - Black for scoop covers.

PRODUCT CODE	PRICE		SIZE/ INCHES			WEIGHT LBS	VOL FT ³
	LP	HP	H	W	D		
EVWR18P	503	578	29	39	19.5	24.00	0.74
EVWR24P	577	668	29	51	25.5	34.00	1.16
EVWR30P	969	1108	29	63	31.5	51.00	1.76

EVTTE • Teardrop Extension Table



- Stand-alone mobile table.

PRODUCT CODE	PRICE		SIZE/ INCHES			WEIGHT LBS	VOL FT ³
	LP	HP	H	W	D		
EVTTE29247	494	579	27	29	29	30.00	15.00
EVTTE34307	542	636	27	34	34	35.00	18.00
EVTTE29249	581	666	29	29	29	30.00	19.00
EVTTE34309	629	724	29	34	34	35.00	19.00

EVWT • Straight Transaction Surface

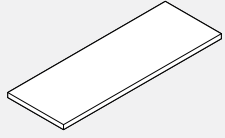

- Support hardware must be ordered separately.
- All tops are thermally fused 1" thick with pilot holes to enable proper alignment with worksurface supports. Wood screws must be used.
- Evolve worksurfaces feature a 3mm edge.

PRODUCT CODE	PRICE		SIZE/ INCHES			WEIGHT VOL	
	LP	HP	H	W	D	LBS	FT ³
EVWT1512	60	77	1	12	15	6.00	0.22
EVWT1518	74	102	1	18	15	8.00	0.30
EVWT1524	93	124	1	24	15	10.00	0.38
EVWT1530	112	146	1	30	15	13.00	0.46
EVWT1536	128	170	1	36	15	15.00	0.54
EVWT1542	146	194	1	42	15	18.00	0.62
EVWT1548	166	217	1	48	15	20.00	0.70
EVWT1554	178	239	1	54	15	23.00	0.78
EVWT1560	199	263	1	60	15	25.00	0.86
EVWT1566	213	284	1	66	15	29.00	0.94
EVWT1572	234	307	1	72	15	30.00	1.02
EVWT1578	249	333	1	78	15	32.00	1.10
EVWT1584	267	353	1	84	15	35.00	1.18

EVWTV • Straight Transaction Surface with Cut-out

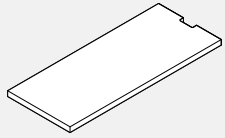

- Used where a transaction surface butts up against a taller panel

PRODUCT CODE	PRICE		SIZE/ INCHES			WEIGHT VOL	
	LP	HP	H	W	D	LBS	FT ³
EVWTV1524	104	134	1	24	15	10.00	0.38
EVWTV1530	126	160	1	30	15	13.00	0.46
EVWTV1536	139	180	1	36	15	15.00	0.54
EVWTV1542	160	204	1	42	15	18.00	0.62
EVWTV1548	176	231	1	48	15	20.57	0.70
EVWTV1554	192	251	1	54	15	22.57	0.75
EVWTV1560	210	275	1	60	15	26.00	0.92
EVWTV1566	229	298	1	66	15	28.00	1.00
EVWTV1572	245	319	1	72	15	30.00	1.08

EVWTCL • "L" Corner Transaction Surface

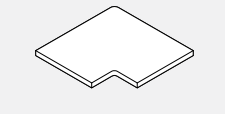

- Used where two panels meet at a 90° angle.
- For Wood Grain Laminate, use code ending with "WG".

PRODUCT CODE	PRICE		SIZE/ INCHES			WEIGHT VOL	
	LP	HP	H	W	D	LBS	FT ³
EVWTCL90	171	212	1	21	15	12.00	0.75
EVWTCL90WG	208	261	1	21	15	12.00	0.75

EVWTCT • "T" Corner Transaction Surface

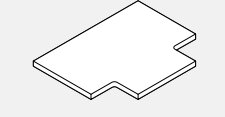

- Used where three panels meet.
- For Wood Grain Laminate, use code ending with "WG".

PRODUCT CODE	PRICE		SIZE/ INCHES			WEIGHT VOL	
	LP	HP	H	W	D	LBS	FT ³
EVWTCT90	171	212	1	27	15	16.00	1.00

EVWTE • End Transaction Surface

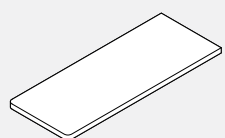

- Surface has rounded corners at one end.

PRODUCT CODE	PRICE		SIZE/ INCHES			WEIGHT VOL	
	LP	HP	H	W	D	LBS	FT ³
EVWTE1512	60	77	1	14	15	12.00	0.54
EVWTE1518	74	102	1	20	15	14.00	0.58
EVWTE1524	104	134	1	26	15	16.00	0.61
EVWTE1530	126	160	1	32	15	20.00	0.69
EVWTE1536	139	180	1	38	15	20.00	0.70
EVWTE1542	160	204	1	44	15	23.00	0.74
EVWTE1548	176	231	1	50	15	26.00	0.77
EVWTE1554	192	251	1	56	15	28.00	0.85
EVWTE1560	210	275	1	62	15	31.00	0.94
EVWTE1566	229	298	1	68	15	34.00	1.02
EVWTE1572	245	319	1	74	15	36.00	1.10

EVWTEV • End Transaction Surface with Cut-out

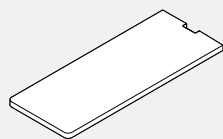

- Used at the end of a panel run where the surface butts up against a taller panel.
- Surface has rounded corners at one end.

PRODUCT CODE	PRICE		SIZE/ INCHES			WEIGHT VOL	
	LP	HP	H	W	D	LBS	FT ³
EVWTEV1524	116	146	1	26	15	16.00	0.61
EVWTEV1530	136	171	1	32	15	18.00	0.65
EVWTEV1536	151	195	1	38	15	20.00	0.69
EVWTEV1542	171	217	1	44	15	23.00	0.74
EVWTEV1548	190	240	1	50	15	32.00	1.22
EVWTEV1554	202	264	1	56	15	36.00	1.32
EVWTEV1560	221	286	1	62	15	36.00	1.30
EVWTEV1566	239	309	1	68	15	30.24	1.14
EVWTEV1572	259	333	1	74	15	40.00	1.38

EVW9TL • Corner Transaction Top for 90 degree Left

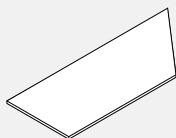

PRODUCT CODE	PRICE		SIZE/ INCHES			WEIGHT VOL	
	LP	HP	H	W	D	LBS	FT ³
EVW9TL1524	394	581	1	33	15	15.00	0.54
EVW9TL1530	475	705	1	39	15	18.00	0.62
EVW9TL1536	551	816	1	45	15	20.00	0.70
EVW9TL1542	631	930	1	51	15	23.00	0.78
EVW9TL1548	712	1050	1	57	15	25.00	0.86

EVW9TR • Corner Transaction Top for 90 degree Right

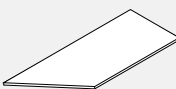

PRODUCT CODE	PRICE		SIZE/ INCHES			WEIGHT VOL	
	LP	HP	H	W	D	LBS	FT ³
EVW9TR1524	394	581	1	33	15	15.00	0.54
EVW9TR1530	475	705	1	39	15	18.00	0.62
EVW9TR1536	551	816	1	45	15	20.00	0.70
EVW9TR1542	631	930	1	51	15	23.00	0.78
EVW9TR1548	712	1050	1	57	15	25.00	0.86

EVWTD • End “D” Transaction Surface

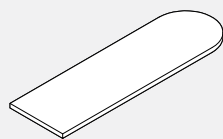

- Used at the end of a panel run where surface can overhang.

PRODUCT CODE	PRICE		SIZE/ INCHES			WEIGHT VOL	
	LP	HP	H	W	D	LBS	FT ³
EVWTD1530	145	190	1	37	15	18.00	0.65
EVWTD1536	153	204	1	43	15	20.00	0.69
EVWTD1542	171	229	1	49	15	23.00	0.74
EVWTD1548	192	251	1	55	15	26.00	0.77
EVWTD1554	207	274	1	61	15	28.00	0.85
EVWTD1560	229	303	1	67	15	31.00	0.94
EVWTD1566	245	323	1	73	15	34.00	1.02
EVWTD1572	265	351	1	79	15	36.00	1.10

EVWTDV • End “D” Transaction Surface with Cut-out

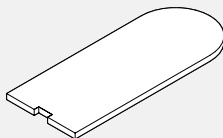

- Used at the end of a panel run where the surface butts up against a taller panel on one end and can overhang at the other.

PRODUCT CODE	PRICE		SIZE/ INCHES			WEIGHT VOL	
	LP	HP	H	W	D	LBS	FT ³
EVWTDV1530	149	201	1	37	15	18.00	0.65
EVWTDV1536	162	217	1	43	15	20.00	0.69
EVWTDV1542	179	239	1	49	15	23.00	0.74
EVWTDV1548	199	264	1	55	15	26.00	0.77
EVWTDV1554	212	284	1	61	15	28.00	0.85
EVWTDV1560	235	312	1	67	15	31.00	0.94

EVWTD • Double “D” Transaction Surface

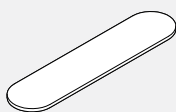

- Support hardware must be ordered separately.
- All tops are thermally fused 1" thick with pilot holes to enable proper alignment with worksurface supports. Wood screws must be used.
- Evolve worksurfaces feature a 3mm edge.

PRODUCT CODE	PRICE		SIZE/ INCHES			WEIGHT VOL	
	LP	HP	H	W	D	LBS	FT ³
EVWTD1548	213	284	1	62	15	28.00	0.85
EVWTD1560	249	333	1	74	15	31.00	0.94
EVWTD1572	289	385	1	86	15	36.00	1.10

EVHEP • End Panel

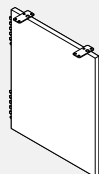

- Attaches a worksurface to a panel connector.
- Provides solid support at the end of a run of worksurfaces.
- Shipped with pedestal brackets and flat brackets.
- Glides are installed.
- Please specify metal colour for brackets.

PRODUCT CODE	PRICE		SIZE/ INCHES			WEIGHT VOL	
	LP	HP	H	W	D	LBS	FT ³
EVHEP2618	187	26	1	18	15.00	0.30	
EVHEP2624	239	25	1	24	16.00	0.35	
EVHEP2630	280	25	1	30	20.00	0.45	
EVHEP2918	197	28	1	18	18.00	0.40	
EVHEP2924	239	28	1	24	18.00	0.40	
EVHEP2930	280	28	1	30	22.00	0.50	

EVHS • Support Leg

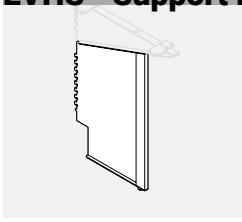

- Used in conjunction with an EVHC Cantilever of the same hand.
- Attaches a worksurface to a panel connector.
- Provides extra support where needed.
- May be used to support two convergent worksurfaces.
- Available in BLK (Black) only.

PRODUCT CODE	PRICE	SIZE/ INCHES			WEIGHT VOL	
		H	W	D	LBS	FT ³
EVHSL2618	126	22	1	10	6.00	0.24
EVHSL2624	126	22	1	10	6.00	0.31
EVHSL2918	133	25	1	10	7.00	0.30
EVHSL2924	133	25	1	10	7.00	0.33
EVHSR2618	126	22	1	10	6.00	0.24
EVHSR2624	126	22	1	10	6.00	0.31
EVHSR2918	133	25	1	10	7.00	0.30
EVHSR2924	133	25	1	10	7.00	0.33

EVHC • Cantilever

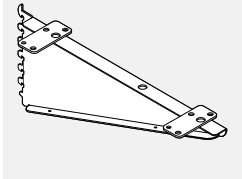

- Attaches a worksurface to a panel connector.
- May be used to support two convergent worksurfaces.
- Priced individually.
- Available in BLK (Black) only.

PRODUCT CODE	PRICE	SIZE/ INCHES			WEIGHT VOL	
		H	W	D	LBS	FT ³
EVHC12L	93	8	1	12	2.00	0.04
EVHC18L	93	8	1	18	2.00	0.04
EVHC24L	104	8	1	24	3.00	0.05
EVHC12R	93	8	1	12	2.00	0.04
EVHC18R	93	8	1	18	2.00	0.04
EVHC24R	104	8	1	24	3.00	0.50

EVHMSL1 • Mid Support Leg

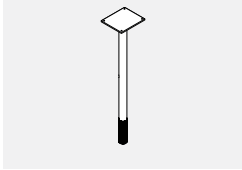

- Provides additional support for worksurface.
- Includes leveling glide, PVC Sleeve and 4.8" x 4.8" attachment plate.
- 1.5 diameter tube.
- Available in standard paint colours.

PRODUCT CODE	PRICE	SIZE/ H	INCHES	WEIGHT VOL	
				LBS	FT ³
EVHMSL1	77	28		3.20	0.37

EVHMSL2 • Mid Support Leg

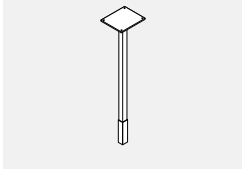

- Provides additional support for worksurface.
- Includes leveling glide, PVC Sleeve and 4.8" x 4.8" attachment plate.
- 1.5" square tube.
- Available in standard paint colours.

PRODUCT CODE	PRICE	SIZE/ H	INCHES	WEIGHT VOL	
				LBS	FT ³
EVHMSL2	77	28		3.20	0.37

EVHMSCL18 • Mid Support Leg with Cantilever Bracket

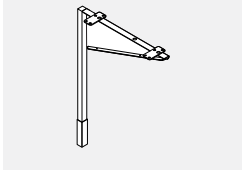

- Provides additional support for worksurface.
- Includes leveling glide, PVC Sleeve and 4.8" x 4.8" attachment plate.
- 1.5" square tube.
- Available in standard paint colours.

PRODUCT CODE	PRICE	SIZE/ INCHES			WEIGHT VOL	
		H	W	D	LBS	FT ³
EVHMSCL18	115	28	18	1.5	5.2	0.55

EVHMEGR - Metal End Gable Round Leg, Non-handed

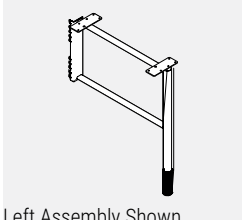

Left Assembly Shown

- **Metal End Gable Leg supports the worksurface and enhances the stability of connected panels.**
- Includes a leveling glide and decorative PVC sleeve to cover the glide.
- Attached to Evolve panel connectors. The mounting bracke is universal and attaches with screws to the back of the leg.
- Please specify standard paint finish.
- NOTE: Cannot be used to support worksurfaces side by side. Please use EVHMSRL12 for supporting adjoining worksurfaces.

PRODUCT CODE	PRICE	SIZE/INCHES			WEIGHT VOL	
		H	W	D	LBS	FT ³
EVHMEGR24	173	29	2	23	6.00	0.73
EVHMEGR30	185	29	2	29	6.80	0.90

EVHMSRL - Metal Mid Support Round Leg

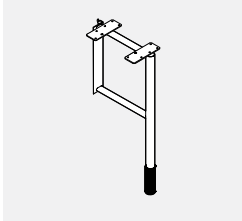

- **Metal Mid Support Leg supports two adjoining worksurfaces and enhances the stability of connected panels.**
- Includes a leveling glide and decorative PVC sleeve to cover the glide.
- Attached to Evolve Panels.
- Please specify standard paint finish.

PRODUCT CODE	PRICE	SIZE/INCHES			WEIGHT VOL	
		H	W	D	LBS	FT ³
EVHMSRL12	149	29	2	11	4.60	0.36

EVHMEGS - Metal End Gable Square Leg, Non-handed

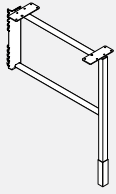

Left Assembly Shown

- **Metal End Gable Leg supports the worksurface and enhances the stability of connected panels.**
- Includes a leveling glide and decorative PVC sleeve to cover the glide.
- Attached to Evolve panel connectors. The mounting bracke is universal and attaches with screws to the back of the leg.
- Please specify standard paint finish.
- NOTE: Cannot be used to support worksurfaces side by side. Please use EVHMSSL12 for supporting adjoining worksurfaces.

PRODUCT CODE	PRICE	SIZE/INCHES			WEIGHT LBS	VOL FT ³
		H	W	D		
EVHMEGS24	177	29	2	23	6.00	0.73
EVHMEGS30	188	29	2	29	6.80	0.90

EVHMSSL - Metal Mid Support Square Leg

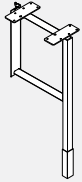

- **Metal Mid Support Leg supports two adjoining worksurfaces and enhances the stability of connected panels.**
- Includes a leveling glide and decorative PVC sleeve to cover the glide.
- Attached to Evolve Panels.
- Please specify standard paint finish.

PRODUCT CODE	PRICE	SIZE/INCHES			WEIGHT LBS	VOL FT ³
		H	W	D		
EVHMSSL12	152	29	2	11	4.60	0.36

EVRTHLEG • Evolve Bridges Leg

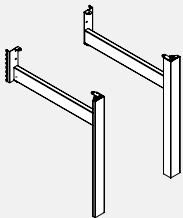

- Leg assembly attaches to panel for application which requires functionality of panels with open enviroment of Bridges tables.
- One leg with horizontal member connects to 1" increment slots in connector.
- Provides support to panel and panel connected 24" & 30" worksurface at end of run-design coordinated with Bridges freestanding tables.
- One leg can support 2 adjoining worksurface by specifying 2 flat brackets.
- Leveling glide is standard.
- Panel cantilever and storage must be for worksurface support.
- One aluminum leg with steel structure - specify left or right and 24" or 30" deep for corresponding worksurface depth.
- Panel bracket, dislodgment clip and worksurface hardware included.
- Anodized aluminum upcharge \$37.
- Please specify paint finish for support.

PRODUCT CODE	PRICE	SIZE/	INCHES		WEIGHT LBS	VOL FT ³
		H	W	D		
EVRTHLEG24LL	353	28	2.5	24	9	1.25
EVRTHLEG24RL	353	28	2.5	24	9	1.25
EVRTHLEG30LL	372	28	2.5	30	11	1.45
EVRTHLEG30RL	372	28	2.5	30	11	1.45

EVHH • High Profile Foot

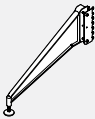

- Provides added support to a panel or worksurface under load.
- Two leveling glides included to adapt to different panel clearances.

PRODUCT CODE	PRICE	SIZE/	INCHES		WEIGHT LBS	VOL FT ³
		H	W	D		
EVHHF01	249	6	1	21	2.80	0.15

EVHML • Monoleg



- Provides support for a worksurface.
- Includes an adjustable foot and an attachment plate.
- 3" diameter.
- 1" Height adjustment range.

PRODUCT CODE	PRICE	SIZE/ H	INCHES W	D	WEIGHT LBS	VOL FT ³
EVHML1	194	28	8	8	8.00	0.15

EVHCB • Corner Bracket



- Attaches the corner of any worksurface to a panel connector.
- Priced per pair.
- Available in BLK (Black) only.

PRODUCT CODE	PRICE	SIZE/ H	INCHES W	D	WEIGHT LBS	VOL FT ³
EVHCB2	26	2	3.5	2.5	0.50	0.02

EVHTB • Transaction Bracket



- Securely attaches a transaction surface to the top of a panel.
- Priced per pair.

PRODUCT CODE	PRICE	SIZE/ H	INCHES W	D	WEIGHT LBS	VOL FT ³
EVHTB2	26	3.5	3.5	2.5	0.50	0.02

EVHFB • Flat Bracket

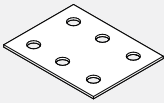

- Must be used in conjunction with cantilevers or transaction brackets to ensure alignment of neighbouring surfaces.

PRODUCT CODE	PRICE	SIZE/ H	INCHES W	D	WEIGHT LBS	VOL FT ³
EVHFB1	21	0.125	3	4	0.50	0.01

EVHZZB • "Z" Bracket



- Used to attach two different worksurface heights with a 3" difference.
- Must be used in conjunction with a cantilever.
- Available in BLK (Black) only.

PRODUCT CODE	PRICE	SIZE/ H	INCHES W	D	WEIGHT LBS	VOL FT ³
EVHZZB1	54	3	17	4	2.00	0.19

EVHPB • Pedestal Bracket



- Attaches to back edge of a pedestal and connects pedestal to panel connector.

PRODUCT CODE	PRICE	SIZE/ H	INCHES W	D	WEIGHT LBS	VOL FT ³
EVHPB1	29	12	1	1	0.50	0.50

EVHWSC • Worksurface Support Channel

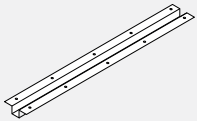

- EVHWSC40 for table 54" wide.
- EVHWSC46 for table 60" wide.
- EVHWSC52 for table 66" wide.
- EVHWSC58 for table 72" wide.
- EVHWSC64 for table 78" wide.
- EVHWSC70 for table 84" wide.
- Tops with post legs should be specified with support channel for structural reinforcement.
- Support channel attaches to underside of worksurface with screws.
- Support channel should be 14" shorter than top length.
- Screws included.
- Painted Black.

PRODUCT CODE	PRICE	SIZE/ H	INCHES W	D	WEIGHT LBS	VOL FT ³
EVHWSC40	58	40	5	4	0.20	
EVHWSC46	64	46	5	6	0.22	
EVHWSC52	68	52	5	7	0.25	
EVHWSC58	78	58	5	8	0.28	
EVHWSC64	88	64	5	9	0.31	
EVHWSC70	94	70	5	10	0.33	

EVHV • Wall Adapter

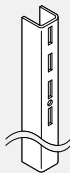

- A "U" shaped channel used to attach system components to a fixed wall.
- Slots are 1" on centre.
- Sold per pair.
- Care should be taken to mount adapters only to wall studs using correct fasteners.
- Failure to do this may result in collapse of the unit and subsequent possible personal injury.
- Mounting hardware is not included.
- Mounting hardware selection to be based on wall material

PRODUCT CODE	PRICE	SIZE/ H	INCHES W	D	WEIGHT LBS	VOL FT ³
EVHV01	74	60	0.5	0.5	4.00	0.01

EVHOMB • Off Module Worksurface Bracket

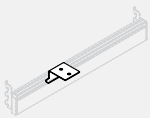

- Supports the worksurface in the work station corner in the case where an adjoining panel is wider than the worksurface.
- Enhances the stability of the worksurface.
- Can be used only in conjunction with the Top Load Bar (EVALB2xx - xx being the panel width - ordered separately)

PRODUCT CODE	PRICE	SIZE/ H	INCHES W	D	WEIGHT LBS	VOL FT ³
EVHOMB1	16	1.6	3	2.73	0.50	0.02

EVLEP • Laminate End Panel

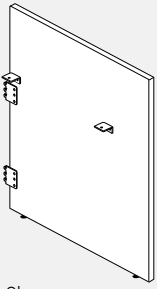

Right Shown

- Attaches to end of run connector.
- Finished in thermally fused laminate.
- Includes attachment flat brackets.
- Includes support brackets to attach worksurface.
- Laminate End Panel height is inclusive of panel glides extended to their full height.
- If wood grain is selected, grain runs vertically.
- Three sides are PVC edged while fourth edge is self-edge. Please choose a PVC edge colour.

PRODUCT CODE	PRICE LP	SIZE/ INCHES		WEIGHT VOL	
		H	W	LBS	FT ³
EVLEPR4224	327	42	24	26.25	0.58
EVLEPR4230	408	42	30	32.81	0.73
EVLEPR4236	487	42	36	39.38	0.88
EVLEPR4242	569	42	42	45.94	1.02
EVLEPR4248	654	42	48	52.50	1.17
EVLEPL4224	327	42	24	30.00	0.67
EVLEPL4230	408	42	30	37.50	0.83
EVLEPL4236	487	42	36	45.00	1.00
EVLEPL4242	569	42	42	52.50	1.17
EVLEPL4248	654	42	48	60.00	1.33
EVLEPR4824	370	48	24	26.25	0.58
EVLEPR4830	465	48	30	32.81	0.73
EVLEPR4836	557	48	36	39.38	0.88
EVLEPR4842	652	48	42	45.94	1.02
EVLEPR4848	744	48	48	52.50	1.17
EVLEPL4824	370	48	24	30.00	0.67
EVLEPL4830	465	48	30	37.50	0.83
EVLEPL4836	557	48	36	45.00	1.00
EVLEPL4842	652	48	42	52.50	1.17
EVLEPL4848	744	48	48	60.00	1.33

EVLMP • Laminate Middle Panel

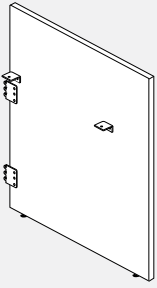

- Attaches to double inline connector.
- Finished in thermally fused laminate.
- Includes attachment flat brackets.
- Includes support brackets to attach worksurfaces on both sides on middle panel.
- Laminate Middle Panel height is inclusive of panel glides extended to their full height.
- If wood grain is selected, grain runs vertically.
- Three sides are PVC edged while fourth edge is self-edge. Please choose a PVC edge colour.

PRODUCT CODE	PRICE LP	SIZE/ INCHES		WEIGHT VOL	
		H	W	LBS	FT ³
EVLMP4224	364	42	24	26.25	0.58
EVLMP4230	442	42	30	32.81	0.73
EVLMP4236	524	42	36	39.38	0.88
EVLMP4242	608	42	42	45.94	1.02
EVLMP4248	694	42	48	52.50	1.17
EVLMP4824	406	48	24	30.00	0.67
EVLMP4830	503	48	30	37.50	0.83
EVLMP4836	595	48	36	45.00	1.00
EVLMP4842	689	48	42	52.50	1.17
EVLMP4848	783	48	48	60.00	1.33

EVLEP-A • Laminate End Panel with Accessory Rail

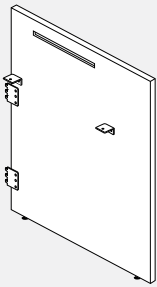

Right Shown

- Attaches to end of run connector.
- Finished in thermally fused laminate.
- Includes attachment flat brackets and accessory rail on inside.
- Includes support brackets to attach worksurface.
- Laminate End Panel height is inclusive of panel glides extended to their full height.
- If wood grain is selected, grain runs vertically.
- Three sides are PVC edged while fourth edge is self-edge. Please choose a PVC edge colour.

PRODUCT CODE	PRICE LP	SIZE/ INCHES		WEIGHT VOL	
		H	W	LBS	FT ³
EVLEPR4224A	370	42	24	26.25	0.58
EVLEPR4230A	450	42	30	32.81	0.73
EVLEPR4236A	535	42	36	39.38	0.88
EVLEPR4242A	614	42	42	45.94	1.02
EVLEPR4248A	699	42	48	52.50	1.17
EVLEPL4224A	370	42	24	30.00	0.67
EVLEPL4230A	450	42	30	37.50	0.83
EVLEPL4236A	535	42	36	45.00	1.00
EVLEPL4242A	614	42	42	52.50	1.17
EVLEPL4248A	699	42	48	60.00	1.33
EVLEPR4824A	411	48	24	26.25	0.58
EVLEPR4830A	501	48	30	32.81	0.73
EVLEPR4836A	565	48	36	39.38	0.88
EVLEPR4842A	644	48	42	45.94	1.02
EVLEPR4848A	790	48	48	52.50	1.17
EVLEPL4824A	411	48	24	30.00	0.67
EVLEPL4830A	501	48	30	37.50	0.83
EVLEPL4836A	565	48	36	45.00	1.00
EVLEPL4842A	644	48	42	52.50	1.17
EVLEPL4848A	790	48	48	60.00	1.33

EVLMP-A • Laminate Middle Panel with Accessory Rail

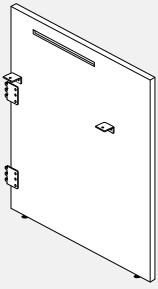

- Attaches to double inline connector.
- Finished in thermally fused laminate.
- Includes accessory rail on both sides of middle panel.
- Includes attachment flat brackets and accessory rail on both sides.
- Includes support brackets to attach worksurfaces on both sides on middle panel.
- Laminate Middle Panel height is inclusive of panel glides extended to their full height.
- If wood grain is selected, grain runs vertically.
- Three sides are PVC edged while fourth edge is self-edge. Please choose a PVC edge colour.

PRODUCT CODE	PRICE LP	SIZE / INCHES		WEIGHT VOL	
		H	W	LBS	FT ³
EVLMP4224A	417	42	24	26.25	0.58
EVLMP4230A	499	42	30	32.81	0.73
EVLMP4236A	582	42	36	39.38	0.88
EVLMP4242A	661	42	42	45.94	1.02
EVLMP4248A	751	42	48	52.50	1.17
EVLMP4824A	456	48	24	30.00	0.67
EVLMP4830A	557	48	30	37.50	0.83
EVLMP4836A	652	48	36	45.00	1.00
EVLMP4842A	744	48	42	52.50	1.17
EVLMP4848A	837	48	48	60.00	1.33

EV4LXP • Laminate Panel Four Way

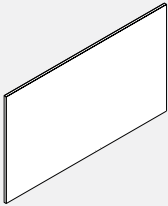

- Panel connects "+" configuration with extension panel
- Finished in thermally fused laminate
- Laminate extension Panel height is inclusive of panel glides extended to their full height
- If wood grain is selected, grain runs horizontally
- Corner connecting brackets to be ordered separately

PRODUCT CODE	PRICE LP	SIZE / INCHES		WEIGHT VOL	
		H	W	LBS	FT ³
EV4LXP4249	535	42	49	53.59	1.19
EV4LXP4261	638	42	61	66.72	1.48
EV4LXP4273	740	42	73	79.84	1.77
EV4LXP4849	607	48	49	61.25	1.36
EV4LXP4861	745	48	61	76.25	1.69
EV4LXP4873	885	48	73	91.25	2.03
EV4LXP5449	678	54	49	68.91	1.53
EV4LXP5461	885	54	61	85.78	1.91
EV4LXP5473	1023	54	73	102.66	2.28

EVLXPML • Laminate Extension Panel

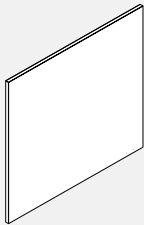

- Locking connection on one sides, no connection at end
- Finished in thermally fused laminate
- Laminate extension Panel height is inclusive of panel glides extended to their full height
- If wood grain is selected, grain runs horizontally
- Bottom connecting brackets to be ordered separately

PRODUCT CODE	PRICE LP	SIZE / INCHES		WEIGHT VOL	
		H	W	LBS	FT ³
EVLXPML4224	284	42	24	26.25	0.58
EVLXPML4230	346	42	30	32.81	0.73
EVLXPML4236	386	42	36	39.38	0.88
EVLXPML4242	435	42	42	45.94	1.02
EVLXPML4248	499	42	48	52.50	1.17
EVLXPMR4224	284	42	24	26.25	0.58
EVLXPMR4230	346	42	30	32.81	0.73
EVLXPMR4236	386	42	36	39.38	0.88
EVLXPMR4242	435	42	42	45.94	1.02
EVLXPMR4248	499	42	48	52.50	1.17
EVLXPML4824	328	48	24	30.00	0.67
EVLXPML4830	378	48	30	37.50	0.83
EVLXPML4836	432	48	36	45.00	1.00
EVLXPML4842	483	48	42	52.50	1.17
EVLXPML4848	535	48	48	60.00	1.33
EVLXPMR4824	328	48	24	30.00	0.67
EVLXPMR4830	378	48	30	37.50	0.83
EVLXPMR4836	432	48	36	45.00	1.00
EVLXPMR4842	483	48	42	52.50	1.17
EVLXPMR4848	535	48	48	60.00	1.33
EVLXPML5424	355	54	24	33.75	0.75
EVLXPML5430	417	54	30	42.19	0.94
EVLXPML5436	477	54	36	50.63	1.13
EVLXPML5442	543	54	42	59.06	1.31
EVLXPML5448	638	54	48	67.50	1.50
EVLXPMR5424	355	54	24	33.75	0.75
EVLXPMR5430	417	54	30	42.19	0.94
EVLXPMR5436	477	54	36	50.63	1.13
EVLXPMR5442	543	54	42	59.06	1.31
EVLXPMR5448	638	54	48	67.50	1.50

EV2LXP • Laminate Extension Panel Two Way

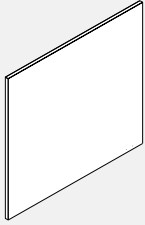

- Panel connects at 90 degree with extension panel
- Finished in thermally fused laminate
- Laminate extension Panel height is inclusive of panel glides extGalleryed to their full height
- If wood grain is selected, grain runs horizontally
- Corner connecting brackets to be ordered separately

PRODUCT CODE	PRICE LP	SIZE / INCHES		WEIGHT LBS	VOL FT ³
		H	W		
EV2LXPL4225	284	42	25	27.34	0.61
EV2LXPL4231	346	42	31	33.91	0.75
EV2LXPL4237	386	42	37	40.47	0.90
EV2LXPL4243	435	42	43	47.03	1.05
EV2LXPL4249	499	42	49	53.59	1.19
EV2LXPR4225	284	42	25	27.34	0.61
EV2LXPR4231	346	42	31	33.91	0.75
EV2LXPR4237	386	42	37	40.47	0.90
EV2LXPR4243	435	42	43	47.03	1.05
EV2LXPR4249	499	42	49	53.59	1.19
EV2LXPL4825	328	48	25	31.25	0.69
EV2LXPL4831	378	48	31	38.75	0.86
EV2LXPL4837	432	48	37	46.25	1.03
EV2LXPL4843	483	48	43	53.75	1.19
EV2LXPL4849	535	48	49	61.25	1.36
EV2LXPR4825	328	48	25	31.25	0.69
EV2LXPR4831	378	48	31	38.75	0.86
EV2LXPR4837	432	48	37	46.25	1.03
EV2LXPR4843	483	48	43	53.75	1.19
EV2LXPR4849	535	48	49	61.25	1.36
EV2LXPL5425	383	54	25	35.16	0.78
EV2LXPL5431	438	54	31	43.59	0.97
EV2LXPL5437	494	54	37	52.03	1.16
EV2LXPL5443	600	54	43	60.47	1.34
EV2LXPL5449	678	54	49	68.91	1.53
EV2LXPR5425	383	54	25	35.16	0.78
EV2LXPR5431	438	54	31	43.59	0.97
EV2LXPR5437	494	54	37	52.03	1.16
EV2LXPR5443	600	54	43	60.47	1.34
EV2LXPR5449	678	54	49	68.91	1.53

EV3LXP • Laminate Extension Panel Three Way

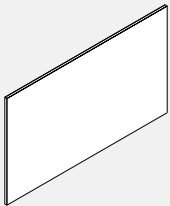

- Panel connects "T" configuration with extension panel
- Finished in thermally fused laminate
- Laminate extension Panel height is inclusive of panel glides extended to their full height
- If wood grain is selected, grain runs horizontally
- Corner connecting brackets to be ordered separately

PRODUCT CODE	PRICE LP	SIZE / INCHES		WEIGHT LBS	VOL FT ³
		H	W		
EV3LXPL4249	535	42	49	53.59	1.19
EV3LXPL4261	638	42	61	66.72	1.48
EV3LXPL4273	740	42	73	79.84	1.77
EV3LXPR4249	535	42	49	53.59	1.19
EV3LXPR4261	638	42	61	66.72	1.48
EV3LXPR4273	740	42	73	79.84	1.77
EV3LXPL4849	607	48	49	61.25	1.36
EV3LXPL4861	745	48	61	76.25	1.69
EV3LXPL4873	885	48	73	91.25	2.03
EV3LXPR4849	607	48	49	61.25	1.36
EV3LXPR4861	745	48	61	76.25	1.69
EV3LXPR4873	885	48	73	91.25	2.03
EV3LXPL5449	678	54	49	68.91	1.53
EV3LXPL5461	885	54	61	85.78	1.91
EV3LXPL5473	1023	54	73	102.66	2.28
EV3LXPR5449	678	54	49	68.91	1.53
EV3LXPR5461	885	54	61	85.78	1.91
EV3LXPR5473	1023	54	73	102.66	2.28

EV4LXPM • Laminate Extension Panel for Four Way Configuration

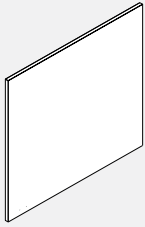

- Locking connection on one side only for four way panel
- Finished in thermally fused laminate
- Universal to be used on both sides of four way laminate panel
- Laminate extension Panel height is inclusive of panel glides extended to their full height
- If wood grain is selected, grain runs horizontally
- Bottom connecting brackets to be ordered separately

PRODUCT CODE	PRICE LP	SIZE / INCHES		WEIGHT LBS	VOL FT ³
		H	W		
EV4LXPM4224	284	42	24	26.25	0.58
EV4LXPM4230	346	42	30	32.81	0.73
EV4LXPM4236	386	42	36	39.38	0.88
EV4LXPM4242	435	42	42	45.94	1.02
EV4LXPM4248	499	42	48	52.50	1.17
EV4LXPM4824	328	48	24	30.00	0.67
EV4LXPM4830	378	48	30	37.50	0.83
EV4LXPM4836	432	48	36	45.00	1.00
EV4LXPM4842	483	48	42	52.50	1.17
EV4LXPM4848	535	48	48	60.00	1.33
EV4LXPM5424	355	54	24	33.75	0.75
EV4LXPM5430	417	54	30	42.19	0.94
EV4LXPM5436	477	54	36	50.63	1.13
EV4LXPM5442	543	54	42	59.06	1.31
EV4LXPM5448	638	54	48	67.50	1.50

EVLXPML-NC - Laminate Extension Panel, No End Connection

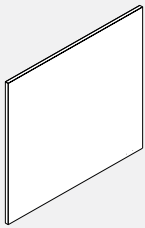

- Locking connection on one sides, no connection at end
- Finished in thermally fused laminate
- Laminate extension Panel height is inclusive of panel glides extended to their full height
- If wood grain is selected, grain runs horizontally
- Bottom connecting brackets to be ordered separately

PRODUCT CODE	PRICE LP	SIZE / INCHES		WEIGHT LBS	VOL FT ³
		H	W		
EVLXPML4224NC	284	42	24	26.25	0.58
EVLXPML4230NC	346	42	30	32.81	0.73
EVLXPML4236NC	386	42	36	39.38	0.88
EVLXPML4242NC	435	42	42	45.94	1.02
EVLXPML4248NC	499	42	48	52.50	1.17
EVLXPMR4224NC	284	42	24	26.25	0.58
EVLXPMR4230NC	346	42	30	32.81	0.73
EVLXPMR4236NC	386	42	36	39.38	0.88
EVLXPMR4242NC	435	42	42	45.94	1.02
EVLXPMR4248NC	499	42	48	52.50	1.17
EVLXPML4824NC	328	48	24	30.00	0.67
EVLXPML4830NC	378	48	30	37.50	0.83
EVLXPML4836NC	432	48	36	45.00	1.00
EVLXPML4842NC	483	48	42	52.50	1.17
EVLXPML4848NC	535	48	48	60.00	1.33
EVLXPMR4824NC	328	48	24	30.00	0.67
EVLXPMR4830NC	378	48	30	37.50	0.83
EVLXPMR4836NC	432	48	36	45.00	1.00
EVLXPMR4842NC	483	48	42	52.50	1.17
EVLXPMR4848NC	535	48	48	60.00	1.33
EVLXPML5424NC	355	54	24	33.75	0.75
EVLXPML5430NC	417	54	30	42.19	0.94
EVLXPML5436NC	477	54	36	50.63	1.13
EVLXPML5442NC	543	54	42	59.06	1.31
EVLXPML5448NC	638	54	48	67.50	1.50
EVLXPMR5424NC	355	54	24	33.75	0.75
EVLXPMR5430NC	417	54	30	42.19	0.94
EVLXPMR5436NC	477	54	36	50.63	1.13
EVLXPMR5442NC	543	54	42	59.06	1.31
EVLXPMR5448NC	638	54	48	67.50	1.50

EVLEPDS • Laminate Gallery Panel

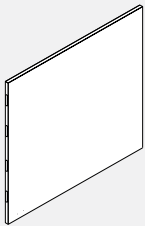

- Attaches to end of run connector with "U" channel
- To be installed at end of panel run
- Finished in thermally fused laminate
- Locking connection both sides
- Laminate Gallery Panel height is inclusive of panel glides extended to their full height
- If wood grain is selected, grain runs horizontally
- End of run connector with "U" channel and bottom connecting brackets to be ordered separately

PRODUCT CODE	PRICE LP	SIZE / INCHES		WEIGHT LBS	VOL FT ³
		H	W		
EVLEPDS4251	535	42	51	55.78	1.24
EVLEPDS4263	695	42	63	68.91	1.53
EVLEPDS4275	857	42	75	82.03	1.82
EVLEPDS4851	607	48	51	63.75	1.42
EVLEPDS4863	773	48	63	78.75	1.75
EVLEPDS4875	937	48	75	93.75	2.08
EVLEPDS5451	678	54	51	71.72	1.59
EVLEPDS5463	885	54	63	88.59	1.97
EVLEPDS5475	1023	54	75	105.47	2.34

EVLEPDC • Laminate Gallery Panel

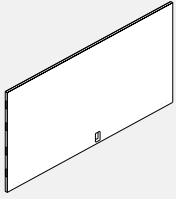

- Attaches in middle of panel run with connector with "U" channel
- To be installed in middle between two panels in straight run
- Finished in thermally fused laminate
- Locking connection both sides
- Laminate Gallery Panel height is inclusive of panel glides extended to their full height
- If wood grain is selected, grain runs horizontally
- End of run connector with "U" channel and bottom connecting brackets to be ordered separately

PRODUCT CODE	PRICE LP	SIZE / INCHES		WEIGHT LBS	VOL FT ³
		H	W		
EVLEPDC4251	535	42	51	55.78	1.24
EVLEPDC4263	695	42	63	68.91	1.53
EVLEPDC4275	857	42	75	82.03	1.82
EVLEPDC4851	607	48	51	63.75	1.42
EVLEPDC4863	773	48	63	78.75	1.75
EVLEPDC4875	937	48	75	93.75	2.08
EVLEPDC5451	678	54	51	71.72	1.59
EVLEPDC5463	885	54	63	88.59	1.97
EVLEPDC5475	1023	54	75	105.47	2.34

EVLEPSSL/R • Laminate Gallery Panel, End Connection on One Side

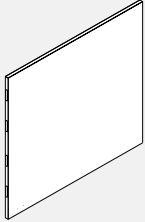

- Attaches to end of run connector with "U" channel
- To be installed at end of panel run on one side
- Finished in thermally fused laminate
- Locking connection on one side
- Laminate Gallery Panel height is inclusive of panel glides extended to their full height
- If wood grain is selected, grain runs horizontally
- End of run connector with "U" channel and bottom connecting brackets to be ordered separately

PRODUCT CODE	PRICE LP	SIZE / INCHES		WEIGHT LBS	VOL FT ³
		H	W		
EVLEPSSL4227	346	42	27	29.53	0.66
EVLEPSSL4233	386	42	33	36.09	0.80
EVLEPSSL4239	435	42	39	42.66	0.95
EVLEPSSL4245	499	42	45	49.22	1.09
EVLEPSSL4251	535	42	51	55.78	1.24
EVLEPSSL4827	378	48	27	33.75	0.75
EVLEPSSL4833	432	48	33	41.25	0.92
EVLEPSSL4839	483	48	39	48.75	1.08
EVLEPSSL4845	535	48	45	56.25	1.25
EVLEPSSL4851	607	48	51	63.75	1.42
EVLEPSSL5427	417	54	27	37.97	0.84
EVLEPSSL5433	477	54	33	46.41	1.03
EVLEPSSL5439	543	54	39	54.84	1.22
EVLEPSSL5445	638	54	45	63.28	1.41
EVLEPSSL5451	678	54	51	71.72	1.59
EVLEPSSR4227	346	42	27	29.53	0.66
EVLEPSSR4233	386	42	33	36.09	0.80
EVLEPSSR4239	435	42	39	42.66	0.95
EVLEPSSR4245	499	42	45	49.22	1.09
EVLEPSSR4251	535	42	51	55.78	1.24
EVLEPSSR4827	378	48	27	33.75	0.75
EVLEPSSR4833	432	48	33	41.25	0.92
EVLEPSSR4839	483	48	39	48.75	1.08
EVLEPSSR4845	535	48	45	56.25	1.25
EVLEPSSR4851	607	48	51	63.75	1.42
EVLEPSSR5427	417	54	27	37.97	0.84
EVLEPSSR5433	477	54	33	46.41	1.03
EVLEPSSR5439	543	54	39	54.84	1.22
EVLEPSSR5445	638	54	45	63.28	1.41
EVLEPSSR5451	678	54	51	71.72	1.59

EVLEPSC • Laminate Gallery Panel

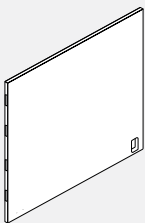

- Attaches in middle of panel run with connector with "U" channel
- To be installed in middle between two panels in straight run on one side
- Cut out for electrics at power beam height
- Finished in thermally fused laminate
- Locking connection on one side
- Laminate Gallery Panel height is inclusive of panel glides extended to their full height
- If wood grain is selected, grain runs horizontally
- End of run connector with "U" channel and bottom connecting brackets to be ordered separately

PRODUCT CODE	PRICE LP	SIZE / INCHES		WEIGHT LBS	VOL FT ³
		H	W		
EVLEPSC4227	346	42	27	29.53	0.66
EVLEPSC4233	386	42	33	36.09	0.80
EVLEPSC4239	435	42	39	42.66	0.95
EVLEPSC4245	499	42	45	49.22	1.09
EVLEPSC4251	535	42	51	55.78	1.24
EVLEPSC4827	378	48	27	33.75	0.75
EVLEPSC4833	432	48	33	41.25	0.92
EVLEPSC4839	483	48	39	48.75	1.08
EVLEPSC4845	535	48	45	56.25	1.25
EVLEPSC4851	607	48	51	63.75	1.42
EVLEPSC5427	417	54	27	37.97	0.84
EVLEPSC5433	477	54	33	46.41	1.03
EVLEPSC5439	543	54	39	54.84	1.22
EVLEPSC5445	638	54	45	63.28	1.41
EVLEPSC5451	678	54	51	71.72	1.59

EVLEPDS-NC • Laminate Gallery Panel, No End Connection at Both Sides

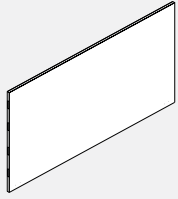

- Attaches to end of run connector with "U" channel
- To be installed at end of panel run
- Finished in thermally fused laminate
- Locking connection both sides
- Laminate Gallery Panel height is inclusive of panel glides extended to their full height
- If wood grain is selected, grain runs horizontally
- End of run connector with "U" channel and bottom connecting brackets to be ordered separately

PRODUCT CODE	PRICE LP	SIZE / INCHES		WEIGHT LBS	VOL FT ³
		H	W		
EVLEPDS4251NC	535	42	51	55.78	1.24
EVLEPDS4263NC	695	42	63	68.91	1.53
EVLEPDS4275NC	857	42	75	82.03	1.82
EVLEPDS4851NC	607	48	51	63.75	1.42
EVLEPDS4863NC	773	48	63	78.75	1.75
EVLEPDS4875NC	937	48	75	93.75	2.08
EVLEPDS5451NC	678	54	51	71.72	1.59
EVLEPDS5463NC	885	54	63	88.59	1.97
EVLEPDS5475NC	1023	54	75	105.47	2.34

EVLEPDC-NC • Laminate Gallery Middle Panel, No End Connection at Both Sides

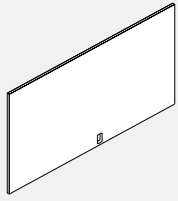

- Attaches in middle of panel run with connector with "U" channel
- To be installed in middle between two panels in straight run
- Finished in thermally fused laminate
- No connection both sides
- Laminate Gallery Panel height is inclusive of panel glides extended to their full height
- If wood grain is selected, grain runs horizontally
- End of run connector with "U" channel and bottom connecting brackets to be ordered separately

PRODUCT CODE	PRICE LP	SIZE / INCHES		WEIGHT LBS	VOL FT ³
		H	W		
EVLEPDC4251NC	535	42	51	55.78	1.24
EVLEPDC4263NC	695	42	63	68.91	1.53
EVLEPDC4275NC	857	42	75	82.03	1.82
EVLEPDC4851NC	607	48	51	63.75	1.42
EVLEPDC4863NC	773	48	63	78.75	1.75
EVLEPDC4875NC	937	48	75	93.75	2.08
EVLEPDC5451NC	678	54	51	71.72	1.59
EVLEPDC5463NC	885	54	63	88.59	1.97
EVLEPDC5475NC	1023	54	75	105.47	2.34

EVLEPSS-NC • Laminate Gallery End Panel, No End Connection at Both Sides

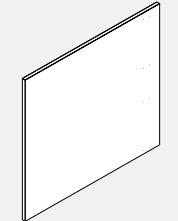

- Attaches in middle of panel run with connector with "U" channel
- To be installed in middle between two panels in straight run
- Finished in thermally fused laminate
- No connection both sides
- Laminate Gallery Panel height is inclusive of panel glides extended to their full height
- If wood grain is selected, grain runs horizontally
- End of run connector with "U" channel and bottom connecting brackets to be ordered separately

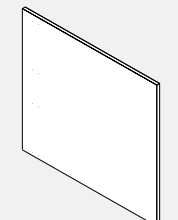

PRODUCT CODE	PRICE LP	SIZE / INCHES		WEIGHT LBS	VOL FT ³
		H	W		
EVLEPSSL4227NC	346	42	27	29.53	0.66
EVLEPSSL4233NC	386	42	33	36.09	0.80
EVLEPSSL4239NC	435	42	39	42.66	0.95
EVLEPSSL4245NC	499	42	45	49.22	1.09
EVLEPSSL4251NC	535	42	51	55.78	1.24
EVLEPSSL4827NC	378	48	27	33.75	0.75
EVLEPSSL4833NC	432	48	33	41.25	0.92
EVLEPSSL4839NC	483	48	39	48.75	1.08
EVLEPSSL4845NC	535	48	45	56.25	1.25
EVLEPSSL4851NC	607	48	51	63.75	1.42
EVLEPSSL5427NC	417	54	27	37.97	0.84
EVLEPSSL5433NC	477	54	33	46.41	1.03
EVLEPSSL5439NC	543	54	39	54.84	1.22
EVLEPSSL5445NC	638	54	45	63.28	1.41
EVLEPSSL5451NC	678	54	51	71.72	1.59
EVLEPSSR4227NC	346	42	27	29.53	0.66
EVLEPSSR4233NC	386	42	33	36.09	0.80
EVLEPSSR4239NC	435	42	39	42.66	0.95
EVLEPSSR4245NC	499	42	45	49.22	1.09
EVLEPSSR4251NC	535	42	51	55.78	1.24
EVLEPSSR4827NC	378	48	27	33.75	0.75
EVLEPSSR4833NC	432	48	33	41.25	0.92
EVLEPSSR4839NC	483	48	39	48.75	1.08
EVLEPSSR4845NC	535	48	45	56.25	1.25
EVLEPSSR4851NC	607	48	51	63.75	1.42
EVLEPSSR5427NC	417	54	27	37.97	0.84
EVLEPSSR5433NC	477	54	33	46.41	1.03
EVLEPSSR5439NC	543	54	39	54.84	1.22
EVLEPSSR5445NC	638	54	45	63.28	1.41
EVLEPSSR5451NC	678	54	51	71.72	1.59

EVLEPSC-NC • Laminate Gallery Middle One Side Panel, No End Connection at Both Sides

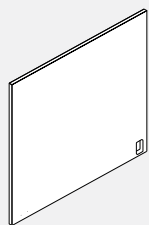

- Attaches in middle of panel run with connector with "U" channel
- To be installed in middle between two panels in straight run on one side
- Cut out for electrics at power beam height
- Finished in thermally fused laminate
- No connection both sides
- Laminate Gallery Panel height is inclusive of panel glides extended to their full height
- If wood grain is selected, grain runs horizontally
- End of run connector with "U" channel and bottom connecting brackets to be ordered separately

PRODUCT CODE	PRICE LP	SIZE / INCHES		WEIGHT LBS	VOL FT ³
		H	W		
EVLEPSC4227NC	346	42	27	29.53	0.66
EVLEPSC4233NC	386	42	33	36.09	0.80
EVLEPSC4239NC	435	42	39	42.66	0.95
EVLEPSC4245NC	499	42	45	49.22	1.09
EVLEPSC4251NC	535	42	51	55.78	1.24
EVLEPSC4827NC	378	48	27	33.75	0.75
EVLEPSC4833NC	432	48	33	41.25	0.92
EVLEPSC4839NC	483	48	39	48.75	1.08
EVLEPSC4845NC	535	48	45	56.25	1.25
EVLEPSC4851NC	607	48	51	63.75	1.42
EVLEPSC5427NC	417	54	27	37.97	0.84
EVLEPSC5433NC	477	54	33	46.41	1.03
EVLEPSC5439NC	543	54	39	54.84	1.22
EVLEPSC5445NC	638	54	45	63.28	1.41
EVLEPSC5451NC	678	54	51	71.72	1.59

EVPBLEPDS • Laminate Gallery Panel for Power Beam, End Connection

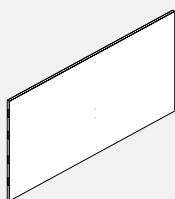

- Attaches to power beam channel
- To be installed at end of power beam run
- Finished in thermally fused laminate
- Locking connection both sides
- Laminate Gallery Panel height is inclusive of panel glides extended to their full height
- If wood grain is selected, grain runs horizontally
- Power beam channel and bottom connecting bracket to be ordered separately

PRODUCT CODE	PRICE LP	SIZE / INCHES		WEIGHT LBS	VOL FT ³
		H	W		
EVPBLEPDS4251	535	42	51	55.78	1.24
EVPBLEPDS4263	695	42	63	68.91	1.53
EVPBLEPDS4275	857	42	75	82.03	1.82
EVPBLEPDS4851	607	48	51	63.75	1.42
EVPBLEPDS4863	773	48	63	78.75	1.75
EVPBLEPDS4875	937	48	75	93.75	2.08
EVPBLEPDS5451	678	54	51	71.72	1.59
EVPBLEPDS5463	885	54	63	88.59	1.97
EVPBLEPDS5475	1023	54	75	105.47	2.34

EVPBLEPDC • Laminate Gallery Panel for Power Beam, Middle Connection

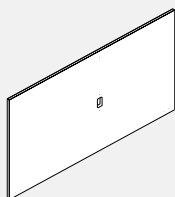

- Attaches to power beam channel
- To be installed in middle between two power beam in straight run
- Cut out for electrics at power beam height
- Finished in thermally fused laminate
- Locking connection both sides
- Laminate Gallery Panel height is inclusive of panel glides extended to their full height
- If wood grain is selected, grain runs horizontally
- Power beam channel and bottom connecting bracket to be ordered separately
- Standard code is for 24" H Power Beam
- Please add at code end "B" for 30"h Power Beam or "C" for 36"h Power Beam

PRODUCT CODE	PRICE LP	SIZE / INCHES		WEIGHT LBS	VOL FT ³
		H	W		
EVPBLEPDC4251	535	42	51	55.78	1.24
EVPBLEPDC4263	695	42	63	68.91	1.53
EVPBLEPDC4275	857	42	75	82.03	1.82
EVPBLEPDC4851	607	48	51	63.75	1.42
EVPBLEPDC4863	773	48	63	78.75	1.75
EVPBLEPDC4875	937	48	75	93.75	2.08
EVPBLEPDC5451	678	48	51	63.75	1.42
EVPBLEPDC5463	885	48	63	78.75	1.75
EVPBLEPDC5475	1023	48	75	93.75	2.08

EVPBLEPSSL/R • Laminate Gallery Panel for Power Beam, End Connection on One Side

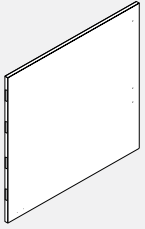

- Attaches to power beam channel
- To be installed at end of power beam run on one side
- Finished in thermally fused laminate
- Locking connection on one side
- Laminate Gallery Panel height is inclusive of panel glides extended to their full height
- If wood grain is selected, grain runs horizontally
- Power beam channel and bottom connecting bracket to be ordered separately

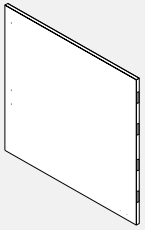

PRODUCT CODE	PRICE LP	SIZE/INCHES		WEIGHT LBS	VOL FT ³
		H	W		
EVPBLEPSSL4227	346	42	27	29.53	0.66
EVPBLEPSSL4233	386	42	33	36.09	0.80
EVPBLEPSSL4239	435	42	39	42.66	0.95
EVPBLEPSSL4245	499	42	45	49.22	1.09
EVPBLEPSSL4251	535	42	51	55.78	1.24
EVPBLEPSSL4827	378	48	27	33.75	0.75
EVPBLEPSSL4833	432	48	33	41.25	0.92
EVPBLEPSSL4839	483	48	39	48.75	1.08
EVPBLEPSSL4845	535	48	45	56.25	1.25
EVPBLEPSSL4851	607	48	51	63.75	1.42
EVPBLEPSSL5427	417	54	27	37.97	0.84
EVPBLEPSSL5433	477	54	33	46.41	1.03
EVPBLEPSSL5439	543	54	39	54.84	1.22
EVPBLEPSSL5445	638	54	45	63.28	1.41
EVPBLEPSSL5451	678	54	51	71.72	1.59
EVPBLEPSSR4227	346	42	27	29.53	0.66
EVPBLEPSSR4233	386	42	33	36.09	0.80
EVPBLEPSSR4239	435	42	39	42.66	0.95
EVPBLEPSSR4245	499	42	45	49.22	1.09
EVPBLEPSSR4251	535	42	51	55.78	1.24
EVPBLEPSSR4827	378	48	27	33.75	0.75
EVPBLEPSSR4833	432	48	33	41.25	0.92
EVPBLEPSSR4839	483	48	39	48.75	1.08
EVPBLEPSSR4845	535	48	45	56.25	1.25
EVPBLEPSSR4851	607	48	51	63.75	1.42
EVPBLEPSSR5427	417	54	27	37.97	0.84
EVPBLEPSSR5433	477	54	33	46.41	1.03
EVPBLEPSSR5439	543	54	39	54.84	1.22
EVPBLEPSSR5445	638	54	45	63.28	1.41
EVPBLEPSSR5451	678	54	51	71.72	1.59

EVPBLEPSC • Laminate Gallery Panel for Power Beam, Middle Connection on One Side

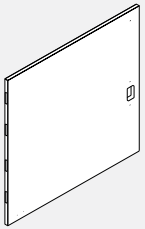

- Attaches to power beam channel
- To be installed in middle between two power beam in straight run on one side
- Cut out for electrics at power beam height
- Finished in thermally fused laminate
- Locking connection on one side
- Laminate Gallery Panel height is inclusive of panel glides extended to their full height
- If wood grain is selected, grain runs horizontally
- Power beam channel and bottom connecting bracket to be ordered separately
- Standard code is for 24" H Power Beam
- Please add at code end "B" for 30"h Power Beam or "C" for 36"h Power Beam

PRODUCT CODE	PRICE LP	SIZE/INCHES		WEIGHT LBS	VOL FT ³
		H	W		
EVPBLEPSC4227	346	42	27	29.53	0.66
EVPBLEPSC4233	386	42	33	36.09	0.80
EVPBLEPSC4239	435	42	39	42.66	0.95
EVPBLEPSC4245	499	42	45	49.22	1.09
EVPBLEPSC4251	535	42	51	55.78	1.24
EVPBLEPSC4827	378	48	27	33.75	0.75
EVPBLEPSC4833	432	48	33	41.25	0.92
EVPBLEPSC4839	483	48	39	48.75	1.08
EVPBLEPSC4845	535	48	45	56.25	1.25
EVPBLEPSC4851	607	48	51	63.75	1.42
EVPBLEPSC5427	417	54	27	37.97	0.84
EVPBLEPSC5433	477	54	33	46.41	1.03
EVPBLEPSC5439	543	54	39	54.84	1.22
EVPBLEPSC5445	638	54	45	63.28	1.41
EVPBLEPSC5451	678	54	51	71.72	1.59

EVPBLEPDS-NC • Laminate Gallery Panel for Power Beam, No End Connection

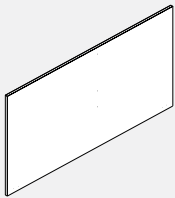

- Attaches to power beam channel
- To be installed at end of power beam run
- Finished in thermally fused laminate
- No connection both sides
- Laminate Gallery Panel height is inclusive of panel glides extended to their full height
- If wood grain is selected, grain runs horizontally
- Power beam channel and bottom connecting bracket to be ordered separately

PRODUCT CODE	PRICE LP	SIZE/INCHES		WEIGHT LBS	VOL FT ³
		H	W		
EVPBLEPDS4251NC	535	42	51	55.78	1.24
EVPBLEPDS4263NC	695	42	63	68.91	1.53
EVPBLEPDS4275NC	857	42	75	82.03	1.82
EVPBLEPDS4851NC	607	48	51	63.75	1.42
EVPBLEPDS4863NC	773	48	63	78.75	1.75
EVPBLEPDS4875NC	937	48	75	93.75	2.08
EVPBLEPDS5451NC	678	54	51	71.72	1.59
EVPBLEPDS5463NC	885	54	63	88.59	1.97
EVPBLEPDS5475NC	1023	54	75	105.47	2.34

EVPBLEPDC-NC • Laminate Gallery Middle Panel for Power Beam, No End Connection at Both Sides

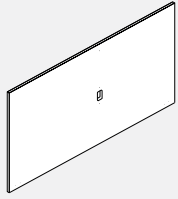

- Attaches to power beam channel
- To be installed in middle between two power beam in straight run
- Cut out for electrics at power beam height
- Finished in thermally fused laminate
- No connection both sides
- Laminate Gallery Panel height is inclusive of panel glides extended to their full height
- If wood grain is selected, grain runs horizontally
- Power beam channel and bottom connecting bracket to be ordered separately
- Standard code is for 24" H Power Beam
- Please add at code end "B" for 30"h Power Beam or "C" for 36"h Power Beam

PRODUCT CODE	PRICE LP	SIZE/INCHES		WEIGHT LBS	VOL FT ³
		H	W		
EVPBLEPDC4251NC	535	42	51	55.78	1.24
EVPBLEPDC4263NC	695	42	63	68.91	1.53
EVPBLEPDC4275NC	857	42	75	82.03	1.82
EVPBLEPDC4851NC	607	48	51	63.75	1.42
EVPBLEPDC4863NC	773	48	63	78.75	1.75
EVPBLEPDC4875NC	937	48	75	93.75	2.08
EVPBLEPDC5451NC	678	48	51	63.75	1.42
EVPBLEPDC5463NC	885	48	63	78.75	1.75
EVPBLEPDC5475NC	1023	48	75	93.75	2.08

EVPBLEPSS-NC • Laminate Gallery End Panel for Power Beam, No End Connection at Both Sides

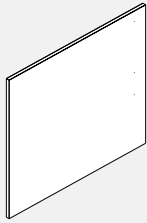

- Attaches to power beam channel
- To be installed at end of power beam run on one side
- Finished in thermally fused laminate
- No connection both sides
- Laminate Gallery Panel height is inclusive of panel glides extended to their full height
- If wood grain is selected, grain runs horizontally
- Power beam channel and bottom connecting bracket to be ordered separately

PRODUCT CODE	PRICE LP	SIZE/INCHES		WEIGHT LBS	VOL FT ³
		H	W		
EVPBLEPSSL4227NC	346	42	27	29.53	0.66
EVPBLEPSSL4233NC	386	42	33	36.09	0.80
EVPBLEPSSL4239NC	435	42	39	42.66	0.95
EVPBLEPSSL4245NC	499	42	45	49.22	1.09
EVPBLEPSSL4251NC	535	42	51	55.78	1.24
EVPBLEPSSL4827NC	378	48	27	33.75	0.75
EVPBLEPSSL4833NC	432	48	33	41.25	0.92
EVPBLEPSSL4839NC	483	48	39	48.75	1.08
EVPBLEPSSL4845NC	535	48	45	56.25	1.25
EVPBLEPSSL4851NC	607	48	51	63.75	1.42
EVPBLEPSSL5427NC	417	54	27	37.97	0.84
EVPBLEPSSL5433NC	477	54	33	46.41	1.03
EVPBLEPSSL5439NC	543	54	39	54.84	1.22
EVPBLEPSSL5445NC	638	54	45	63.28	1.41
EVPBLEPSSL5451NC	678	54	51	71.72	1.59
EVPBLEPSSR4227NC	346	42	27	29.53	0.66
EVPBLEPSSR4233NC	386	42	33	36.09	0.80
EVPBLEPSSR4239NC	435	42	39	42.66	0.95
EVPBLEPSSR4245NC	499	42	45	49.22	1.09
EVPBLEPSSR4251NC	535	42	51	55.78	1.24
EVPBLEPSSR4827NC	378	48	27	33.75	0.75
EVPBLEPSSR4833NC	432	48	33	41.25	0.92
EVPBLEPSSR4839NC	483	48	39	48.75	1.08
EVPBLEPSSR4845NC	535	48	45	56.25	1.25
EVPBLEPSSR4851NC	607	48	51	63.75	1.42
EVPBLEPSSR5427NC	417	54	27	37.97	0.84
EVPBLEPSSR5433NC	477	54	33	46.41	1.03
EVPBLEPSSR5439NC	543	54	39	54.84	1.22
EVPBLEPSSR5445NC	638	54	45	63.28	1.41
EVPBLEPSSR5451NC	678	54	51	71.72	1.59

EVPBLEPSC-NC • Laminate Gallery Middle One Side Panel for Power Beam, No End Connection at Both Sides

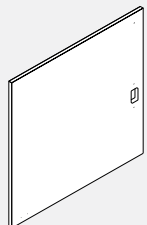

- Attaches to power beam channel
- To be installed in middle between two power beam in straight run on one side
- Cut out for electrics at power beam height
- Finished in thermally fused laminate
- No connection both sides
- Laminate Gallery Panel height is inclusive of panel glides extended to their full height
- If wood grain is selected, grain runs horizontally
- Power beam channel and bottom connecting bracket to be ordered separately
- Standard code is for 24" H Power Beam
- Please add at code end "B" for 30"h Power Beam or "C" for 36"h Power Beam

PRODUCT CODE	PRICE LP	SIZE/INCHES		WEIGHT LBS	VOL FT ³
		H	W		
EVPBLEPSC4227NC	346	42	27	29.53	0.66
EVPBLEPSC4233NC	386	42	33	36.09	0.80
EVPBLEPSC4239NC	435	42	39	42.66	0.95
EVPBLEPSC4245NC	499	42	45	49.22	1.09
EVPBLEPSC4251NC	535	42	51	55.78	1.24
EVPBLEPSC4827NC	378	48	27	33.75	0.75
EVPBLEPSC4833NC	432	48	33	41.25	0.92
EVPBLEPSC4839NC	483	48	39	48.75	1.08
EVPBLEPSC4845NC	535	48	45	56.25	1.25
EVPBLEPSC4851NC	607	48	51	63.75	1.42
EVPBLEPSC5427NC	417	54	27	37.97	0.84
EVPBLEPSC5433NC	477	54	33	46.41	1.03
EVPBLEPSC5439NC	543	54	39	54.84	1.22
EVPBLEPSC5445NC	638	54	45	63.28	1.41
EVPBLEPSC5451NC	678	54	51	71.72	1.59

EVHLPBB01 • Laminate Panel Bracket

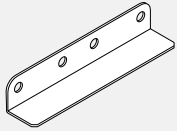

- Laminate panel bottom bracket connects two laminate end panels at bottom with screws
- Available in standard paint colors
- Bracket and screws included

PRODUCT CODE	PRICE	SIZE/INCHES			WEIGHT LBS	VOL FT ³
		H	W	D		
EVHLPBB01	35	1.5	8	1	0.50	0.11

EVHLPCB01 • Laminate Panel Corner Bracket

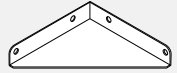

- Laminate panel corner bottom bracket connects two laminate panels at 90 degree
- Available in standard paint colors
- Bracket and screws included

PRODUCT CODE	PRICE	SIZE/INCHES			WEIGHT LBS	VOL FT ³
		H	W	D		
EVHLPCB01	34	1.5	4	4	0.50	0.11

EVPERCH • Connector with U Channel



- U channel attaches with screws to laminate end panel or laminate middle panel
- Evolve panels attaches to connector
- Pass thru at bottom and beltline location for power/data
- U channel is welded to connector
- Includes connector with U channel and hardware

PRODUCT CODE	PRICE	SIZE/INCHES		WEIGHT LBS	VOL FT ³
		H	W		
EVPERCH42	133	42	2.875	4.60	0.14
EVPERCH48	140	48	2.875	5.09	0.18
EVPERCH54	151	54	2.875	6.75	0.22

EVPBIECH • Power Beam Channel



- One piece channel for power beam and extension module above, attaches to laminate panels with screws
- Power beam attaches to channel with clamps and extension module attaches above
- Channel has cut out for power beam electrics to run thru laminate panel

Note

- It is not stackable.
- It can not be stacked with standard extension connector above it.

PRODUCT CODE	PRICE	SIZE/INCHES		WEIGHT LBS	VOL FT ³
		H	W		
EVPBIECH12	38	12	2.875	1.32	0.12
EVPBIECH18	42	18	2.875	1.94	0.18
EVPBIECH24	53	24	2.875	2.60	0.24
EVPBIECH30	56	30	2.875	3.30	0.30
EVPBIECH36	61	36	2.875	4.60	0.36

EVSL12 • Laminated Shelf for Reception Panels

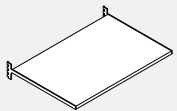

- Laminated Wood Shelf Panel Mounted
- Shelf thickness 1"
- Available in LP
- Includes attachment hardware

PRODUCT CODE	PRICE	SIZE/INCHES			WEIGHT LBS	VOL FT ³
		H	W	D		
EVSL1218	197	1.125	18	12	4.98	0.13
EVSL1224	212	1.125	24	12	6.64	0.17
EVSL1230	226	1.125	30	12	8.3	0.21
EVSL1236	239	1.125	36	12	9.96	0.25
EVSL1242	253	1.125	42	12	11.63	0.29
EVSL1248	268	1.125	48	12	13.29	0.33

EVPTTAU • Connector with U Channel Top Trim Aluminum

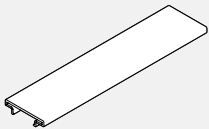

- Aluminum top trim longer by 0.625" to cover width of connector with U channel
- Trim can not span a post
- Available in standard paint colors

PRODUCT CODE	PRICE	SIZE/INCHES		WEIGHT LBS	VOL FT ³
		W	D		
EVPTTAU24	19	24.625	0.19	0.04	
EVPTTAU30	24	30.625	0.24	0.05	
EVPTTAU36	27	36.625	0.28	0.06	
EVPTTAU42	30	42.625	0.33	0.07	
EVPTTAU48	35	48.625	0.37	0.08	
EVPTTAU54	38	54.625	0.42	0.09	
EVPTTAU60	46	60.625	0.46	0.10	
EVPTTAU66	48	66.625	0.51	0.11	
EVPTTAU72	49	72.625	0.56	0.12	
EVPTTAU78	57	78.625	0.60	0.13	
EVPTTAU84	60	84.625	0.65	0.14	

EVPTTA • Aluminum Top Trim for Double Inline Connector (for use with laminate end and middle panels)

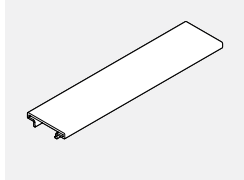

- Used for panels in middle of run of panels with Double Inline Connector.
- Aluminum Top Trim covers panel and one Double Inline Connector.
- Available in standard paint colours.
- Note: Trim can not span a Post Connector.

PRODUCT CODE	PRICE	SIZE/	INCHES		WEIGHT VOL	
			W	LBS	FT ³	
EVPTTA25	19		25.125	0.19	0.04	
EVPTTA31	24		31.125	0.24	0.05	
EVPTTA37	27		37.125	0.28	0.06	
EVPTTA43	30		43.125	0.33	0.07	
EVPTTA49	35		49.125	0.37	0.08	
EVPTTA55	38		55.125	0.42	0.09	
EVPTTA61	46		61.125	0.46	0.10	
EVPTTA67	48		67.125	0.51	0.11	
EVPTTA73	49		73.125	0.56	0.12	
EVPTTA79	57		79.125	0.60	0.13	
EVPTTA85	60		83.125	0.65	0.14	

EVPTTA • Aluminum Top Trim for Double Inline Connector (for use with laminate end and middle panels)

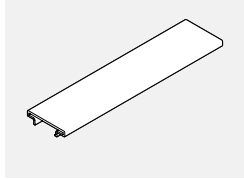

- Used for panels next to end of run trim in run of panels with Double Inline Connector.
- Available in standard paint colours.
- Note: Trim can not span a Post Connector.

PRODUCT CODE	PRICE	SIZE/	INCHES		WEIGHT VOL	
			W	LBS	FT ³	
EVPTTA24	16		24	0.22	0.04	
EVPTTA30	23		30	0.29	0.05	
EVPTTA36	25		36	0.30	0.06	
EVPTTA42	29		42	0.34	0.07	
EVPTTA48	34		48	0.38	0.08	
EVPTTA54	37		54	0.42	0.09	
EVPTTA60	43		60	0.46	0.10	
EVPTTA66	46		66	0.50	0.11	
EVPTTA72	48		72	0.55	0.12	
EVPTTA78	56		78	0.59	0.12	
EVPTTA84	60		84	0.64	0.13	

EVPGDCP • Gallery panel data post

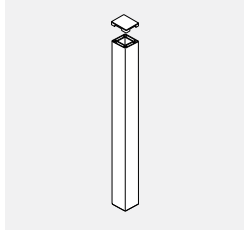

- One way post attaches to Gallery Panel at the end to bring power and/or data cables from ceiling to Evolve panels.
- Accommodates up to 25 CAT 5 cables with electric. Accommodates up to 45 CAT 5 cables without electric.
- Middle Gallery panel with bottom cut out for electrics must be ordered.
- Standard data post extension used above.
- Standard data post extension to be ordered separately.
- Choose standard paint finish.

PRODUCT CODE	PRICE	SIZE/	INCHES		WEIGHT VOL	
			H	W	LBS	FT ³
EVPGDCP42	176	42	3			
EVPGDCP48	208	48	3			
EVPGDCP54	227	54	3			

EVPMP-GI6W • Privacy Glass for 1" Laminate Panels

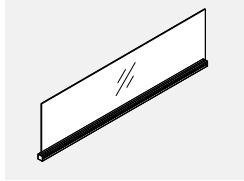

- Privacy glass integrated with aluminum trim.
- Attaches on top of 1" laminate panels to add privacy or divide space.
- Includes aluminum trim with end caps and glass tile.
- Aluminum trim has rail for accessories.
- Standard in clear (CLR), frosted (FRST) or writeable (WRW) glass.
- Glass and attachment hardware to ship separately.

PRODUCT CODE	PRICE			SIZE/INCHES			WEIGHT VOL	
	CL`	FRST	WRW	H	W	D	LBS	FT ³
EVPMP24GI6W	201	251	-	6	24	1	2.39	0.25
EVPMP30GI6W	219	276	-	6	30	1	2.99	0.32
EVPMP36GI6W	235	291	-	6	36	1	3.58	0.37
EVPMP42GI6W	251	313	-	6	42	1	4.18	0.43
EVPMP48GI6W	262	327	-	6	48	1	4.78	0.50
EVPMP24GI9W	201	251	-	9	24	1	3.58	0.25
EVPMP30GI9W	219	276	-	9	30	1	4.48	0.32
EVPMP36GI9W	235	291	-	9	36	1	5.37	0.37
EVPMP42GI9W	251	313	-	9	42	1	6.26	0.43
EVPMP48GI9W	262	327	-	9	48	1	7.16	0.50
EVPMP24GIW	201	251	350	12	24	1	4.77	0.50
EVPMP30GIW	219	276	357	12	30	1	5.97	0.63
EVPMP36GIW	235	291	364	12	36	1	7.16	0.75
EVPMP42GIW	251	313	401	12	42	1	8.35	0.87
EVPMP48GIW	262	327	439	12	48	1	9.55	1.00

EVPFDW • Felt divider for 1" Laminate Panels

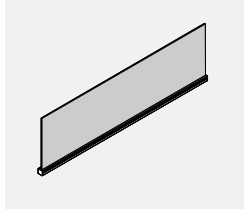

- Privacy Felt Divider integrated with aluminum top trim. Attaches on top of laminate panels to add privacy or divide space.
- Includes aluminum trim with channel and felt tile.
- Felt and attachment hardware to ship separately.
- 9 mm felt material is tackable and comes in 18 different colors. Please specify felt finish.
- Aluminum top trim available in standard paint finishes.

PRODUCT CODE	PRICE	SIZE/INCHES			WEIGHT VOL	
		H	W	D	LBS	FT ³
EVPFD0624W	72	6	24	1	1.42	0.26
EVPFD0630W	88	6	30	1	1.73	0.32
EVPFD0636W	102	6	36	1	2.03	0.37
EVPFD0642W	114	6	42	1	2.34	0.43
EVPFD0648W	170	6	48	1	2.64	0.50
EVPFD0654W	183	6	54	1	2.95	0.56
EVPFD0660W	199	6	60	1	3.25	0.63
EVPFD0666W	210	6	66	1	3.56	0.69
EVPFD0672W	238	6	72	1	3.86	0.76
EVPFD0924W	72	9	24	1	1.63	0.38
EVPFD0930W	88	9	30	1	1.99	0.47
EVPFD0936W	102	9	36	1	2.35	0.56
EVPFD0942W	114	9	42	1	2.70	0.65
EVPFD0948W	170	9	48	1	3.06	0.75
EVPFD0954W	183	9	54	1	3.42	0.84
EVPFD0960W	199	9	60	1	3.78	0.94
EVPFD0966W	210	9	66	1	4.13	1.04
EVPFD0972W	238	9	72	1	4.49	1.13
EVPFD1224W	72	12	24	1	1.84	0.50
EVPFD1230W	88	12	30	1	2.25	0.63
EVPFD1236W	102	12	36	1	2.66	0.75
EVPFD1242W	114	12	42	1	3.07	0.87
EVPFD1248W	170	12	48	1	3.48	1.00
EVPFD1254W	183	12	54	1	3.89	1.12
EVPFD1260W	199	12	60	1	4.30	1.25
EVPFD1266W	210	12	66	1	5.12	1.38
EVPFD1272W	238	12	72	1	5.53	1.51
EVPFD1824W	92	18	24	1	2.26	0.75
EVPFD1830W	108	18	30	1	2.77	0.94
EVPFD1836W	128	18	36	1	3.29	1.13
EVPFD1842W	143	18	42	1	3.80	1.31
EVPFD1848W	212	18	48	1	4.32	1.50
EVPFD1854W	231	18	54	1	4.83	1.69
EVPFD1860W	248	18	60	1	5.35	1.88
EVPFD1866W	262	18	66	1	6.68	2.06
EVPFD1872W	298	18	72	1	7.20	2.25

EVPDIC • Double Inline Panel Connector (for use with Laminate Middle Panels)

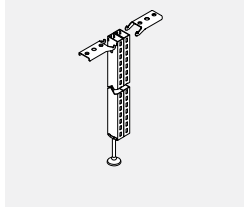

- Used to connect Laminate Middle Panel to panels of equal height in straight run.
- Aluminum Top Trim for Double Inline Connector must be used.
- Provides slotted support for worksurfaces and hang on storage compartments. Includes two slotted post with levelling glide and connection hardware.
- Connectors available without clots as special at no charge. Contact Customer Service.

PRODUCT CODE	PRICE	SIZE/ INCHES		WEIGHT VOL	
		H	W	LBS	FT ³
EVPDIC42	136	42	2	9.20	0.14
EVPDIC48	144	48	2	10.50	0.14

EVPDVTF • Double Connector Trim (for use with Laminate Middle Panels)

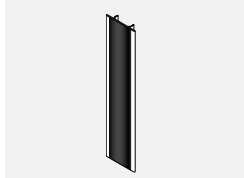

- Attaches to exposed side of double Inline Connector
- Must be ordered separately when Laminate Middle Panel is attached only to one side of Double Inline Connector.

PRODUCT CODE	PRICE	SIZE/ INCHES		WEIGHT VOL	
		H	W	LBS	FT ³
EVPDVTF42	13	42	2	0.52	0.07
EVPDVTF48	21	48	2	0.75	0.09

Technical Information for 9300 Series Pedestals

General Information:

9300 Series Pedestals feature center pull handles (models ending in "C") and full pull handles (models ending in "P"). Freestanding, mobile, and worksurface supporting options available. Quality steel construction. File drawers hold letter or A4 front to back and legal side to side configurations. Products are finished in a highly durable dry epoxy powder coating and drawer body interiors are finished with 100% recycled paint. Counterweights are included in freestanding and mobile pedestals to meet applicable ANSI/BIFMA X5.9.

Features:

- Cold rolled steel construction consisting of 16 ga front and back base with 22 ga case
- Reinforced welded construction
- Inset drawer fronts and flush base
- Double wall construction on all drawer fronts
- Full extension ball bearing slides on file drawers and $\frac{3}{4}$ extension on box drawers
- Rubber bumpers on slides for quietness
- Worksurface supporting option available (includes mounting holes at top of unit)
- 1 pencil tray and 1 drawer divider are included with each unit containing a box drawer
- Each file drawer includes a hanging file bar
- Levelers provide 1" height adjustment
- Counterweights included for freestanding and mobile pedestals
- Includes lock with 2 keys
- Lock is located at the top right of the case above the top drawer
- Keyed alike option available and can be keyed alike to other storage components

Technical Information for Prime Series

General Information:

Prime premium filing and storage products pre-configured to suit your needs; featuring fixed front or receding doors with full pull handles and fully welded seamless tops to deliver strength and clean aesthetics. Premium quality steel construction. File drawers accommodate legal, letter or A4 sizes in back-to-front and side-to-side configurations. Products are finished in a highly durable dry epoxy powder coating and drawer body interiors are finished with 100% recycled paint.

Counterweights are recommended for use in all laterals, pedestals and freestanding files of all widths and heights to meet applicable ANSI/BIFMA X5.9. (Counterweights are offered as an option on all products where required to meet applicable ANSI/BIFMA standard)

Features

- Premium steel construction, 18-22 gauge steel components
- Full welded and reinforced case construction
- Interlock system allows only one drawer to open at a time for safety
- Most products feature full overlay fronts, with some exceptions such as units with receding doors where the front is inset in the case
- Double wall construction on all drawer and door fronts
- Full extension roller bearing glides on all drawers
- Anti-bounce-back safety feature prevents drawers from sliding open
- Receding doors slide into the cabinet and allow the shelf to be pulled out
- All pedestals are equipped with four levelling glides, providing 1.5" of height adjustment
- All other units equipped with four levelling glides providing 1" height adjustment and can be accessed from the interior of the cabinets for ease of adjustment
- On units with drawers and hinged doors, locks are located at the center of the case above the top opening
- Lock position on towers with wardrobes is below the handle when center pull is selected
- Each lock includes 2 keys; locks are standard with removable cores
- Key assignment is random or can be specified for specific key number for key alike applications

Overhead Storage:

- Overhead cabinets - 7 widths in 6" increments
- 14 5/8" high cases with interior clear height of 12"
- 13" deep units have interior clear dimension of 12.7"
- 16" deep units have interior clear dimension of 15.7"
- Open shelves - 7 widths in 6" increments
- Shelves are 12 1/2" deep with 7 1/2" high side gables

Sizes:

- 15" width
- 19", 23", 29" depths
- Interior drawer depths:

19" Deep pedestals
17 1/4" deep box drawers
16 1/16" deep file drawers

23" deep pedestals
20 3/16" deep box drawers
19 7/16" deep file drawers

29" deep pedestals
26 5/16" deep box drawers
26 1/16" deep file drawers

Drawer Heights:

Box drawer fronts are 6"H with 5" interior height
File drawer fronts are 12"H with 10 9/16" interior height

Pedestals:

- Freestanding and worksurface supporting options available
- Worksurface supporting includes mounting holes at top of unit
- 1 pencil tray and 1 drawer divider are included with each unit containing a box drawer
- File drawers hold legal, letter or A4 sizes in back-to-front and side-to-side configurations
- Each file drawer includes a hanging file bar and conversion rails
- Freestanding units BSPF can be specified with optional non-locking casters to convert to a mobile unit
- 15" width x 18", 22", 28" depths

Interior drawer depth is as follows:

- 15" deep drawers for 18" deep pedestals
- 19" deep drawers for 22" deep pedestals
- 25" deep drawers for 28" deep pedestals

File drawer capacity:

- 14 3/8" filing capacity for file drawers in 18" pedestal
- 18 3/8" filing capacity for file drawers in 22" pedestal
- 24 3/8" filing capacity for file drawers in 28" pedestal

Laterals:

- 18" depth with interior depth of 16"
- 30", 36", 42" widths
- Available in 2 to 6 drawer high (28"h – 77.6"h)

File Drawer Capacity:

- 30" wide units
- Letter & legal side-to-side = 26 5/8"
 - Letter front-to-back = 30 1/2"
 - Legal front-to-back = 15 1/4" + 10" side space
- 36" wide units
- Letter & legal side-to-side = 32 5/8"
 - Letter front-to-back = 30 1/2" + 6 1/2" side space
 - Legal front-to-back = 30 1/2"
- 42" wide units
- Letter & legal side-to-side = 58 5/8"
 - Letter front-to-back = 45 3/4"
 - Legal front-to-back = 30 1/2" + 6 1/2" side space

Technical Information for Prime Series

Storage Cabinets:

- 18" depth
- 30", 36", 42" widths
- Available in 2 to 5 high configurations (28"h – 65.6"h)

Towers:

- Include coat rod and shelf to accommodate personal items
- The top of the storage compartment is perforated for ventilation
- Includes locks with 2 keys each
 - Closed storage comes with 3 locks – one of the drawers, one for the cupboard, and one for the wardrobe
 - Side open storage comes with 2 locks – one of the drawers and one for the ward-

robe

- 24" depth
- 24" width
- 50", 54", and 66" nominal heights available to coordinate with Global's panel systems

STORAGE COMPONENTS - GUIDELINES FOR ORDERING PRODUCT

Codes

The price list uses a numbering system with meaningful alphanumeric characters to create a simple-to-understand product number. This makes specifying the product much easier and more accurate.

How to Specify

- Specify storage pedestal type and size by code, including depth.
- Specify metal color (eg. BLK for Black)
- Specify key random, key list provided, or key number (eg. 401)
- Specify worksurface supporting (1 = Yes, 2 = No)
- Specify counterweight if pedestal is not worksurface supporting (NN = No Counterweight)

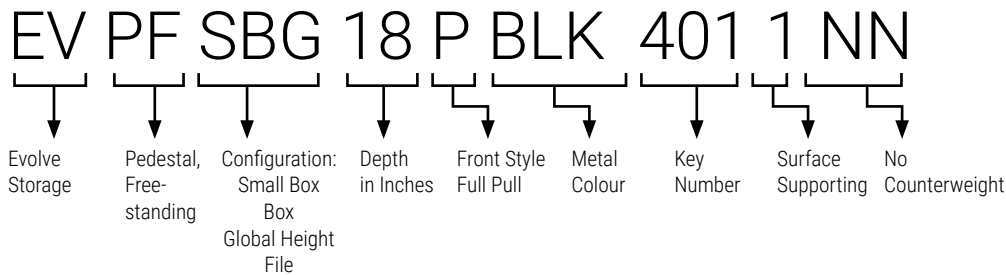

EVSLs • Low Profile Shelf

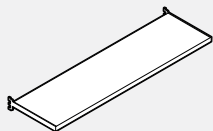

- Laminated Wood Shelf Panel Mounted
- Shelf thickness 1.125".
- Available in LP only.
- Includes attachment hardware.

PRODUCT CODE	PRICE	SIZE/ INCHES			WEIGHT VOL	
		H	W	D	LBS	FT ³
EVSLs0818	210	1.125	18	8.5	3.98	0.09
EVSLs0824	229	1.125	24	8.5	5.31	0.12
EVSLs0830	248	1.125	30	8.5	6.64	0.15
EVSLs0836	264	1.125	36	8.5	7.97	0.18
EVSLs0842	284	1.125	42	8.5	9.30	0.21
EVSLs0848	301	1.125	48	8.5	10.63	0.24

EVKSS • Panel Mount Shelf

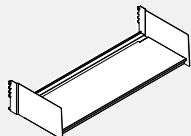

- 14" deep panel mounted storage shelf with backlip.
- Mounting brackets are included.

PRODUCT CODE	PRICE	SIZE/ INCHES			WEIGHT VOL	
		H	W	D	LBS	FT ³
EVKSS24	133	7.45	23.44	14.73	12.8	1.5
EVKSS30	141	7.45	29.44	14.73	14.8	1.9
EVKSS36	155	7.45	35.44	14.73	16.8	2.3
EVKSS42	161	7.45	41.44	14.73	18.8	2.6
EVKSS48	172	7.45	47.44	14.73	20.8	3.0
EVKSS54	179	7.45	53.44	14.73	22.8	3.4
EVKSS60	184	7.45	59.44	14.73	24.8	3.8

EVLSF • Flush Front Overhead Cabinet

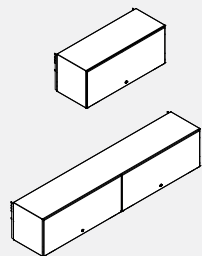

Cabinets 54" and 60" wide come with two doors

- Flush Front Overhead Cabinet is panel mounted lockable storage unit.
- The door retracts inside/within the overhead cabinet.
- Locks can be keyed alike to match other lockable storage components or keyed random to provide a dedicated lock.
- Available in 13" and 16" depths, 24" to 60" widths at 6" increments.
- Cabinets 54" and 60" wide come with two doors.
- Includes mounting hardware as specified, lock and keys.
- Lock secures into bottom shelf.
- Can be mounted at any height, however 66"h panels are recommended.
- Shipped assembled.

PRODUCT CODE	PRICE	SIZE/ INCHES			WEIGHT VOL	
		H	W	D	LBS	FT ³
EVLSF1324MN	540	14.62	23.87	13.5	39.30	2.7
EVLSF1330MN	558	14.62	29.87	13.5	44.3	3.4
EVLSF1336MN	614	14.62	35.87	13.5	49.3	4.1
EVLSF1342MN	672	14.62	41.87	13.5	54.3	4.8
EVLSF1348MN	731	14.62	47.87	13.5	59.3	5.5
EVLSF1354MN	788	14.62	53.87	13.5	64.3	6.2
EVLSF1360MN	844	14.62	59.87	13.5	69.3	6.8
EVLSF1624MN	893	14.62	23.87	16.5	38.6	3.4
EVLSF1630MN	916	14.62	29.87	16.5	43.9	4.2
EVLSF1636MN	960	14.62	35.87	16.5	49.2	5.0
EVLSF1642MN	1024	14.62	41.87	16.5	54.5	5.8
EVLSF1648MN	1089	14.62	47.87	16.5	59.8	6.7
EVLSF1654MN	1148	14.62	53.87	16.5	65.1	7.5
EVLSF1660MN	1200	14.62	59.87	16.5	70.4	8.4

EVADA-PM • Easy-Up Panel Mounted Overhead Storage Unit - AODA Compliant

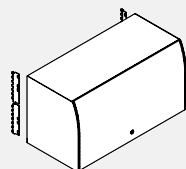

- Meets CSA B651 Barrier Free Design & AODA (Accessibility for Ontarians with Disabilities Act).
- 16" high units accept standard and A4 binders.
- All shelves are reinforced for proper weight distribution.
- Inside dimensions: 14.25" high x 13.4" deep.
- Unit includes attachment hardware, lock and mounting brackets. Back not included.
- Not recommended for use with wall rails.
- Shipped partially assembled.
- Unit can be converted to an Up-Mount Overhead Storage in the field by adding EVADA-KIT.

With opaque acrylic door. The mechanism lifts the door up and stores it out of the way, above the storage unit.

PRODUCT CODE	PRICE	SIZE/ INCHES			WEIGHT VOL	
		H	W	D	LBS	FT ³
EVADA30PM	839	16	30	14.2	27.00	5.30
EVADA36PM	906	16	36	14.2	32.00	6.30
EVADA42PM	970	16	42	14.2	37.00	7.30
EVADA48PM	1037	16	48	14.2	42.00	8.30
EVADA54PM	1101	16	54	14.2	47.00	9.30
EVADA60PM	1167	16	60	14.2	53.00	10.30

EVADAPMKIT • Panel Mount Conversion Kit



- Converts an existing Up-Mount Overhead Storage Unit EVADA-UM to a Panel Mounted Overhead Storage Unit EVADA-PM.
- Kit includes panel mounting brackets.

PRODUCT CODE	PRICE	SIZE/ INCHES			WEIGHT VOL	
		H	W	D	LBS	FT ³
EVADAPMKIT	40	16	0.5	2	2.00	0.01

EVADA-UM • Easy-Up Up-Mount Overhead Storage Unit - AODA Compliant

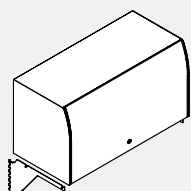

- Meets CSA B651 Barrier Free Design & AODA (Accessibility for Ontarians with Disabilities Act).
- 16" high units accept standard and A4 binders.
- All shelves are reinforced for proper weight distribution.
- Inside dimensions: 14.25" high x 13.4" deep.
- Unit includes attachment hardware, lock, mounting cantilevers and has a finished back.
- Unit can be converted to an Panel Mounted Overhead Storage Unit in the field by adding EVADAPM-KIT.
- Shipped partially assembled.

Up-mounted storage can reduce furniture costs by reducing the height of all panels to 54". Complete 54" panel installations simplify cable routing at one level, below the top cap. Up-mounted cantilevers maintain accessibility and functionality of the panels' top lay-in channel below the top cap.

PRODUCT CODE	PRICE	SIZE/ INCHES			WEIGHT VOL	
		H	W	D	LBS	FT ³
EVADA30UM	999	16	30	14.2	33.00	5.30
EVADA36UM	1046	16	36	14.2	40.00	6.30
EVADA42UM	1105	16	42	14.2	46.00	7.30
EVADA48UM	1166	16	48	14.2	53.00	8.30
EVADA54UM	1222	16	54	14.2	59.00	9.30
EVADA60UM	1293	16	60	14.2	66.00	10.30

EVADA-KIT • Up-Mount Conversion Kit

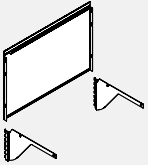

- Converts an existing Panel Mounted Overhead Storage Unit EVADA-PM to an Up-Mounted Overhead Storage Unit EVADA-UM.
- When used on a 54" high panel, the top of the overhead can match the height of 66" high panels.
- Kit includes a back panel for the Overhead and Up-Mount Cantilevers.

PRODUCT CODE	PRICE	SIZE/ INCHES			WEIGHT VOL	
		H	W	D	LBS	FT ³
EVADA30KIT	201	16	30	2	8.00	0.60
EVADA36KIT	210	16	36	2	10.00	0.70
EVADA42KIT	225	16	42	2	11.00	0.80
EVADA48KIT	235	16	48	2	13.00	0.90
EVADA54KIT	247	16	54	2	14.00	1.00
EVADA60KIT	261	16	60	2	15.00	1.10

EVSDAOHL36 • Dual Access Overhead Left

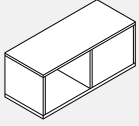

- Inside dimensions 13" high x 13" deep.
- Laminate Overhead.
- Available in standard Evolve laminate finishes.
- Top mount on panels.
- Dual Access Overhead Support Brackets to be ordered separately.

PRODUCT CODE	PRICE	SIZE/ INCHES			WEIGHT VOL	
		H	W	D	LBS	FT ³
EVSDAOHL36	1037	15	36	14.12	46.97	4.40
EVSDAOHL42	1118	15	42	14.12	52.84	5.13
EVSDAOHL48	1164	15	48	14.12	58.90	5.87
EVSDAOHL54	1246	15	54	14.12	64.97	6.61
EVSDAOHL60	1294	15	60	14.12	71.03	7.35

EVSDAOHR36 • Dual Access Overhead Right

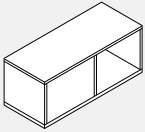

- Inside dimensions 13" high x 13" deep.
- Laminate Overhead.
- Available in standard Evolve laminate finishes.
- Top mount on panels.
- Dual Access Overhead Support Brackets to be ordered separately.

PRODUCT CODE	PRICE	SIZE/ INCHES			WEIGHT VOL	
		H	W	D	LBS	FT ³
EVSDAOHR36	1037	15	36	14.12	46.97	4.40
EVSDAOHR42	1118	15	42	14.12	52.84	5.13
EVSDAOHR48	1164	15	48	14.12	58.90	5.87
EVSDAOHR54	1246	15	54	14.12	64.97	6.61
EVSDAOHR60	1294	15	60	14.12	71.03	7.35

EVSDAOHBKTE • End of run Bracket

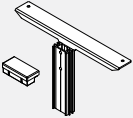

- Bracket supports dual access overhead on one side only.
- Includes one bracket, aluminum insert and end of run plastic cap.
- End of run plastic cap attaches to end of run trim.
- Bracket available in standard Evolve paint finishes.

PRODUCT CODE	PRICE	SIZE/ INCHES			WEIGHT VOL	
		H	W	D	LBS	FT ³
EVSDAOHBKTE	91	6.5	2	12	1	0.09

EVSDAOHBKTS • Inline Single Bracket

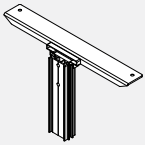

- Bracket supports dual access overhead on one side only.
- Includes one bracket, aluminum insert and inline plastic cap.
- Inline plastic cap and top trim align.
- Bracket available in standard Evolve paint finishes.
- Note: Single clamps must be used when inline single bracket is used.

PRODUCT CODE	PRICE	SIZE/ INCHES			WEIGHT VOL	
		H	W	D	LBS	FT ³
EVSDAOHBKTS	91	6.5	4	12	1.6	0.09

EVSDAOHBKTD • Double Bracket

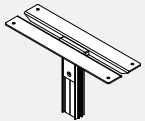

- Double Bracket supports sides of dual access overheads when overhead are side by side.
- Includes two brackets, aluminum insert and plastic caps.
- Plastic caps installed between bracket.
- Brackets available in standard Evolve paint finishes.
- **Note:** Single clamps must be used when double bracket is used.

PRODUCT CODE	PRICE	SIZE/ INCHES			WEIGHT VOL	
		H	W	D	LBS	FT ³
EVSDAOHBKTD	181	6.5	4	12	1.6	0.18

EVSSOHL • Top Mount KD Overhead with Sliding Glass Door Left

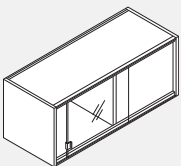

- Inside dimensions 13" high x 13" deep
- Laminate side walls and divider, available in standard laminate finishes
- Metal shelves and back wall, available in standard paint finishes
- Available in tempered frosted glass only
- Tracks for sliding glass available in Tungsten only
- Top mount on panels
- Ready for quick assembly on site
- Top Mount Overhead Support Brackets to be ordered separately.

PRODUCT CODE	PRICE	SIZE/ INCHES			WEIGHT VOL	
		H	W	D	LBS	FT ³
EVSSOHL30	1049	15	30	15	63.00	3.66
EVSSOHL36	1158	15	36	15	64.00	4.40
EVSSOHL42	1276	15	42	15	66.00	5.13
EVSSOHL48	1359	15	48	15	68.00	5.87
EVSSOHL54	1438	15	54	15	70.00	6.61
EVSSOHL60	1571	15	60	15	72.00	7.35

EVSSOHR • Top Mount KD Overhead with Sliding Glass Door Right

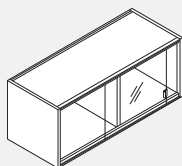

- Inside dimensions 13" high x 13" deep.
- Laminate side walls and divider, available in standard laminate finishes.
- Metal shelves and back wall, available in standard paint finishes.
- Available in tempered frosted glass only.
- Tracks for sliding glass available in Tungsten only.
- Top mount on panels.
- Ready for quick assembly on site .
- Top Mount Overhead Support Brackets to be ordered separately.

PRODUCT CODE	PRICE	SIZE/ H	INCHES W	D	WEIGHT LBS	VOL FT³
EVSSOHR30	1049	15	30	15	63.00	3.66
EVSSOHR36	1158	15	36	15	64.00	4.40
EVSSOHR42	1276	15	42	15	66.00	5.13
EVSSOHR48	1359	15	48	15	68.00	5.87
EVSSOHR54	1438	15	54	15	70.00	6.61
EVSSOHR60	1571	15	60	15	72.00	7.35

EVSSOHBKTE • End of run Top Mount Overhead Bracket

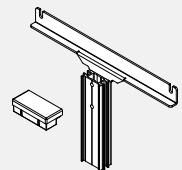

- Bracket supports Top Mount KD overhead on one side only.
- Includes one bracket , aluminum insert and end of run plastic cap.
- End of run plastic cap attaches to end of run trim.
- Bracket available in standard Evolve paint finishes.

PRODUCT CODE	PRICE	SIZE/ H	INCHES W	D	WEIGHT LBS	VOL FT³
EVSSOHBKTE	91	6	2	12	1	0.07

EVSSOHBKTS • Inline Single Top Mount Overhead Bracket

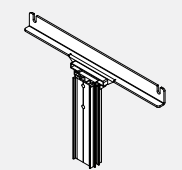

- Bracket supports Top Mount KD overhead on one side only.
- Includes one bracket , aluminum insert and inline plastic cap.
- Inline plastic cap and top trim align.
- Bracket available in standard Evolve paint finishes.
- **Note:** Single clamps must be used when inline single bracket is used.

PRODUCT CODE	PRICE	SIZE/ H	INCHES W	D	WEIGHT LBS	VOL FT³
EVSSOHBKTS	91	15	36	12	1	0.07

EVSSOHBKTD • Double Top Mount Overhead Bracket

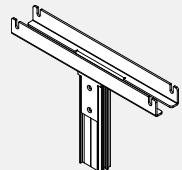

- Double Bracket supports sides of Top Mount KD overheads when overhead are side by side.
- Includes two brackets, aluminum insert and plastic caps.
- Plastic caps installed between brackets.
- Brackets available in standard Evolve paint finishes.
- **Note:** Single clamps must be used when double bracket is used.

PRODUCT CODE	PRICE	SIZE/ H	INCHES W	D	WEIGHT LBS	VOL FT³
EVSSOHBKTD	91	15	36	12	1.6	0.09

EVSODOMB • Overhead Off Module Mount Conversion Kit

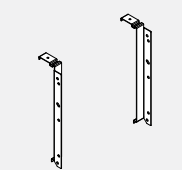

- Converts any existing EVADA overheads to off module installed.
- Allows to install overhead of different widths of Premium Panel.
- Attaches to top horizontal tube of Premium Fabric Panel.
- Brackets allow to install Double Wall Overhead or AODA overhead.
- Kit includes pair of brackets.
- Available in standard paint finishes.

PRODUCT CODE	PRICE	SIZE/ H	INCHES W	D	WEIGHT LBS	VOL FT³
EVSODOMB	95	12.37	1	4.37	0.25	0.09

EV93FPxxBFP • 9300 Series Freestanding Box File Pedestal

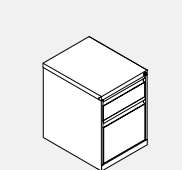

- One box and one file drawer pedestal.
- Freestanding, counterweight included.
- All drawers are locking.
- Box drawer includes pencil tray.

PRODUCT CODE	PRICE	SIZE/ H	INCHES W	D	WEIGHT LBS	VOL FT³
EV93FP19BFP	559	21.31	15	19	50	5.1
EV93FP23BFP	566	21.31	15	23	55	6.0
EV93FP29BFP	678	21.31	15	29	64	7.5

EV93FPxxBBFP • 9300 Series Freestanding Box Box File Pedestal

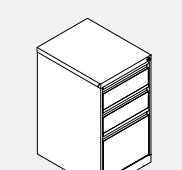

- Two box and one file drawer pedestal.
- Freestanding, counterweight included.
- All drawers are locking.
- Top box drawer includes pencil tray.

PRODUCT CODE	PRICE	SIZE/ H	INCHES W	D	WEIGHT LBS	VOL FT³
EV93FP19BBFP	617	27.87	15	19	55	6.5
EV93FP23BBFP	628	27.87	15	23	68	7.7
EV93FP29BBFP	741	27.87	15	29	78	9.6

EV93FPxxFFP • 9300 Series Freestanding File File Pedestal

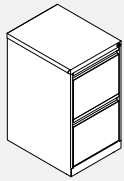

- Two file drawer pedestal.
- Freestanding, counterweight included.
- All drawers are locking.

PRODUCT CODE	PRICE	SIZE/ INCHES			WEIGHT VOL	
		H	W	D	LBS	FT ³
EV93FP19FFP	589	27.87	15	19	53	6.5
EV93FP23FFP	597	27.87	15	23	60	7.7
EV93FP29FFP	699	27.87	15	29	70	9.6

EV93WPxxBBFP • 9300 Series Worksurface Supporting Box Box File Pedestal

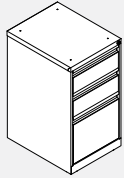

- Two box and one file drawer pedestal.
- Worksurface supporting, includes mounting holes in the top.
- All drawers are locking.
- Top box drawer includes pencil tray.
- To use as a worksurface supporting pedestal, please specify EVHPB6 separately.

PRODUCT CODE	PRICE	SIZE/ INCHES			WEIGHT VOL	
		H	W	D	LBS	FT ³
EV93WP19BBFP	613	27.87	15	19	55	6.5
EV93WP23BBFP	621	27.87	15	23	68	7.7
EV93WP29BBFP	711	27.87	15	29	78	9.6

EV93WPxxFFP • 9300 Series Worksurface Supporting File File Pedestal

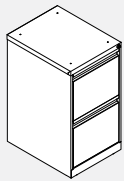

- Two file drawer pedestal.
- Worksurface supporting, includes mounting holes in the top.
- All drawers are locking.
- To use as a worksurface supporting pedestal, please specify EVHPB6 separately.

PRODUCT CODE	PRICE	SIZE/ INCHES			WEIGHT VOL	
		H	W	D	LBS	FT ³
EV93WP19FFP	582	27.87	15	19	53	6.5
EV93WP23FFP	587	27.87	15	23	60	7.7
EV93WP29FFP	700	27.87	15	29	70	9.6

EV93MPxxBFP • 9300 Series Mobile Box File Pedestal

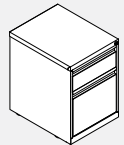

- One box and one file drawer mobile pedestal.
- Casters preinstalled, casters non-locking.
- Counterweight included.
- All drawers locking.
- Box drawer includes pencil tray.
- NOTE: Cannot be used as guest seating.

PRODUCT CODE	PRICE	SIZE/ INCHES			WEIGHT VOL	
		H	W	D	LBS	FT ³
EV93MP19BFP	659	21.87	15	19	66	5.2
EV93MP23BFP	681	21.87	15	23	72	6.2
EV93MP29BFP	730	21.87	15	29	92	7.6

EV93MPxxBBFP • 9300 Series Mobile Box Box File Pedestal

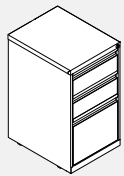

- Two box and one file drawer mobile pedestal.
- Casters preinstalled, casters non-locking.
- Counterweight included.
- All drawers locking.
- Top box drawer includes pencil tray.
- NOTE: Cannot be used as guest seating.

PRODUCT CODE	PRICE	SIZE/ INCHES			WEIGHT VOL	
		H	W	D	LBS	FT ³
EV93MP19BBFP	695	27.93	15	19	76	6.5
EV93MP23BBFP	702	27.93	15	23	85	7.7
EV93MP29BBFP	757	27.93	15	29	94	9.6

EV93MPxxFFP • 9300 Series Mobile File File Pedestal

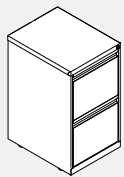

- Two file drawer pedestal.
- Casters preinstalled, casters non-locking.
- Counterweight included.
- All drawers locking.
- NOTE: Cannot be used as guest seating.

PRODUCT CODE	PRICE	SIZE/ INCHES			WEIGHT VOL	
		H	W	D	LBS	FT ³
EV93MP19FFP	654	27.93	15	19	73	6.5
EV93MP23FFP	681	27.93	15	23	81	7.7
EV93MP29FFP	748	27.93	15	29	90	9.6

EVPFOBFxxP • Prime Freestanding Box File Pedestal

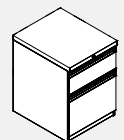

- One box and one file drawer pedestal.
- All drawers are locking.
- Box drawer includes pencil tray.
- For freestanding, to add counterweight (W2 option), add \$50 list.
- For mobile to add casters and counterweight (W1 option), add \$75 list. Adds 0.5" to height.
- NOTE: Cannot be used as guest seating.

PRODUCT CODE	PRICE	SIZE/ INCHES			WEIGHT VOL	
		H	W	D	LBS	FT ³
EVPFOBF18P	571	20.8	15	18	52.4	4.2
EVPFOBF22P	579	20.8	15	22	58.8	5.0
EVPFOBF28P	656	20.8	15	28	68.7	6.3

EVPFSGxxP • Prime Box Box File Pedestal

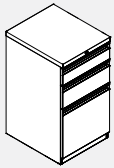

- Two box and one file drawer pedestal.
- All drawers are locking.
- Top box drawer includes pencil tray.
- For freestanding, to add counterweight (W2 option), add \$50 list.
- For mobile to add casters and counterweight (W1 option), add \$75 list. Adds 0.5" to height.
- Top box drawer 4.8"h; middle box drawer 6.4"h; bottom file drawer 13.6"h (interior 12.5"h).
- When worksurface supporting option selected, unit includes pre-drilled top holes for attaching.
- To use as a worksurface supporting pedestal, please specify EVHPB5 separately.

PRODUCT CODE	PRICE	SIZE/ INCHES			WEIGHT VOL	
		H	W	D	LBS	FT ³
EVPFSG18P	637	28	15	18	67.5	5.5
EVPFSG22P	644	28	15	22	75	6.6
EVPFSG28P	710	28	15	28	86.8	8.3

EVPFOFGxxP • Prime File File Pedestal

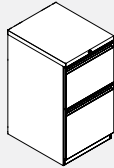

- Two file drawer pedestal.
- All drawers are locking.
- For freestanding, to add counterweight (W2 option), add \$50 list.
- For mobile to add casters and counterweight (W1 option), add \$75 list. Adds 0.5" to height.
- Top file drawer 11.2"h (interior 10.6"h); bottom file drawer 13.6"h (interior 12.5"h).
- When worksurface supporting option selected, unit includes pre-drilled top holes for attaching.
- To use as a worksurface supporting pedestal, please specify EVHPB5 separately.

PRODUCT CODE	PRICE	SIZE/ INCHES			WEIGHT VOL	
		H	W	D	LBS	FT ³
EVPFOFG18P	637	28	15	18	67.5	5.5
EVPFOFG22P	644	28	15	22	75	6.6
EVPFOFG28P	710	28	15	28	86.8	8.3

EVPWOBFxxP • Prime Mobile Box File Pedestal



- Mobile one box and one file drawer pedestal.
- All drawers are locking.
- 60mm casters.
- Front casters are locking.

PRODUCT CODE	PRICE	SIZE/ INCHES			WEIGHT VOL	
		H	W	D	LBS	FT ³
EVPWOBF18P	758	23.3	15	18	73.5	4.6
EVPWOBF22P	763	23.3	15	22	79.1	5.6
EVPWOBF28P	878	23.3	15	28	87.7	7.0

EVPWSSFxxP • Prime Mobile Box Box File Pedestal



- Mobile two box and one file drawer pedestal.
- All drawers are locking.
- 60mm casters.
- Front casters are locking.

PRODUCT CODE	PRICE	SIZE/ INCHES			WEIGHT VOL	
		H	W	D	LBS	FT ³
EVPWSSF18P	800	26.5	15	18	82.9	5.2
EVPWSSF22P	807	26.5	15	22	89.3	6.3
EVPWSSF28P	928	26.5	15	28	99.2	7.9

EVSTC • Pedestal/Lateral Seat Cushion

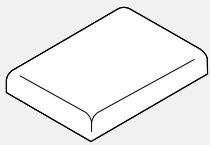

PRODUCT CODE	YRDS	SIZE/ INCHES			WEIGHT VOL	
		H	W	D	LBS	FT ³
EVSTCL1830	1.00	2	18	30	6.00	0.55
EVSTCL1836	1.25	2	18	36	6.00	0.65
EVSTCP1518	0.75	2	15	18	5.00	0.41
EVSTCP1522	1.00	2	15	22	5.25	0.45
EVSTCP1528	1.00	2	15	28	5.50	0.55

• C.O.M. Fabrics are priced as Grade 3.

PRODUCT CODE	PRICE																			
	GR1	GR2	GR3	GR4	GR5	GR6	GR7	GR8	GR9	GR10	GR11	GR12	GR13	GR14	GR15	GR16	GR17	GR18	GR19	GR20
EVSTCL1830	289	328	355	394	450	503	552	603	655	712	783	886	987	1089	1317	1541	1772	1996	2221	2471
EVSTCL1836	343	391	430	475	543	608	673	733	801	869	960	1089	1214	1343	1628	1908	2194	2474	2757	3070
EVSTCP1518	202	233	252	280	323	364	401	435	477	518	574	652	724	802	972	1142	1312	1482	1652	1839
EVSTCP1522	212	240	264	291	333	372	411	448	486	528	582	659	736	813	984	1153	1324	1495	1661	1848
EVSTCP1528	267	305	336	371	426	480	534	579	631	688	759	864	964	1065	1294	1517	1747	1973	2198	2448

EVFELT03BC - Felt Shelf Liner for Cube Pedestals

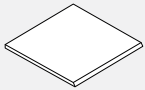

- Felt shelf liner can be added to any closed back shelf.
- Front edge is cut at 45 degree.

PRODUCT CODE	PRICE	SIZE/ H	INCHES W	D	WEIGHT LBS	VOL FT³
EVFTFELT03BC	23	12	12	0.38	0.1	0.03

EVSSPH12BFB • Cube Hanging Pedestal, One File Box and Two Open Boxes

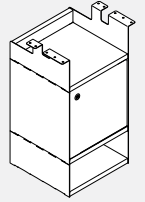

- Hanging pedestal with one file box in the middle and two open boxes, one at the top and one at the bottom.
- Attaches to the underside of a worksurface with supplied screws.
- File box interior dimensions: 11 7/8" h x 11 13/16" w x 10 7/16" d.
- Includes chrome wire divider and optional lock.
- Metal wire divider is chrome and sits 3 7/16" from either side and is interchangeable.
- File door lock, if specified is located on the top right corner for the right pedestal and top left corner for the left pedestal.
- Bottom, middle and top shelves, front door and back are made of 3/4" low pressure laminate.
- Sides are made of powder coated metal.
- Ships knocked-down.

PRODUCT CODE	PRICE	SIZE/ H	INCHES W	D	WEIGHT LBS	VOL FT³
Without Lock						
EVSSPH12BFBR	444	24	12	12	26	2.33
EVSSPH12BFBL	444	24	12	12	26	2.33
With Lock						
EVSSPH12BFBKR	457	24	12	12	26	2.33
EVSSPH12BFBKL	457	24	12	12	26	2.33

EVSSPH12BF • Cube Hanging Pedestal, One File Box

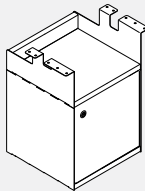

- Hanging pedestal with one file box at the bottom and one open box at the top.
- Attaches to the underside of a worksurface with supplied screws.
- File box interior dimensions: 11 7/8" h x 11 13/16" w x 10 7/16" d.
- Includes chrome wire divider and optional lock.
- Metal wire divider is chrome and sits 3 7/16" from either side and is interchangeable.
- File door lock, if specified is located on the top right corner for the right pedestal and top left corner for the left pedestal.
- Bottom, middle and top shelves, front door and back are made of 3/4" low pressure laminate.
- Sides are made of powder coated metal.
- Ships knocked-down.

PRODUCT CODE	PRICE	SIZE/ H	INCHES W	D	WEIGHT LBS	VOL FT³
Without Lock						
EVSSPH12BFR	334	18.5	12	12	20	1.83
EVSSPH12BFL	334	18.5	12	12	20	1.83
With Lock						
EVSSPH12BFKR	347	18.5	12	12	20	1.83
EVSSPH12BFKL	347	18.5	12	12	20	1.83

EVSSPH12B • Cube Hanging Pedestal Box

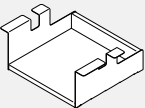

- Hanging pedestal open box.
- Attaches to the underside of a worksurface with supplied screws to create an open box.
- Bottom, middle and top shelves, front door and back are made of 3/4" low pressure laminate.
- Sides are made of powder coated metal.
- Ships knocked-down.

PRODUCT CODE	PRICE	SIZE/ H	INCHES W	D	WEIGHT LBS	VOL FT³
EVSSPH12B	136	6	12	12	6	0.96

EVSSPH12BB • Cube Hanging Pedestal, Two Open Boxes

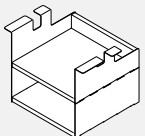

- Hanging pedestal with two open boxes.
- Attaches to the underside of a worksurface with supplied screws.
- Bottom, middle and top shelves, front door and back are made of 3/4" low pressure laminate.
- Sides are made of powder coated metal.
- Ships knocked-down.

PRODUCT CODE	PRICE	SIZE/ H	INCHES W	D	WEIGHT LBS	VOL FT³
EVSSPH12BB	251	11.5	12	12	12	1.42

EVT • Lateral File Tops

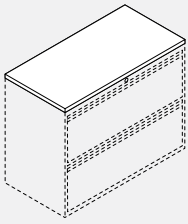

- Made of 1" or 1/16" thick particle board with laminate finish and edged in 3.0 mm edge banding.

PRODUCT CODE	PRICE		SIZE/ INCHES			WEIGHT VOL	
	LP	HP	H	W	D	LBS	FT ³
EVT1830	151	213	1.0625	30	18	18.00	0.70
EVT1836	177	239	1.0625	36	18	22.00	0.82
EVT1842	207	318	1.0625	42	18	26.00	0.92
EVT1860	286	486	1.0625	60	18	37.00	1.27
EVT1872	340	550	1.0625	72	18	44.00	1.50
EVT1884	464	625	1.0625	84	18	52.00	1.85
EVT1890	502	682	1.0625	90	18	56.00	1.85
EVT18108	624	853	1.0625	108	18	67.00	2.20

EVLPS0BF18xxP • Prime Box File Lateral

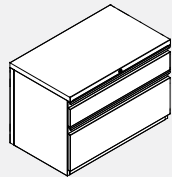

- One and a half height lateral filing cabinet.
- Fixed front drawers, top box drawer front 4.8" bottom file drawer front 13.6" (interior 12.5").
- Locking.
- Side to side hanging bars included.
- To add counterweight (W2 option), add \$410 list.

PRODUCT CODE	PRICE	SIZE/INCHES			WEIGHT VOL	
		H	W	D	LBS	FT ³
EVLPS0BF1830P	1268	20.98	30	18.06	119.96	8.0
EVLPS0BF1836P	1320	20.98	36	18.06	129.86	9.5
EVLPS0BF1842P	1364	20.98	42	18.06	165.45	11.1

EVL20G18xxP • Prime 2 High Lateral File

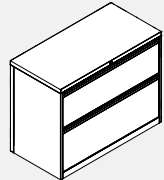

- Two high lateral filing cabinet.
- Fixed front file drawers, top drawer front 11.2" (interior 10.6") bottom drawer front 13.6" (interior 12.5").
- Locking.
- Side to side hanging bars included.
- To add counterweight (W2 option), add \$200 list.

PRODUCT CODE	PRICE	SIZE/INCHES			WEIGHT VOL	
		H	W	D	LBS	FT ³
EVL20G1830P	1268	28	30	18	98.7	10.5
EVL20G1836P	1327	28	36	18	114.4	12.5
EVL20G1842P	1399	28	42	18	129.4	14.5

EVL30G18xxP • Prime 3 High Lateral File

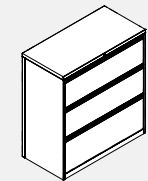

- Three high lateral filing cabinet.
- Fixed front file drawers, top & middle drawer front 11.2" (interior 10.6") bottom drawer front 13.6" (interior 12.5").
- Locking.
- Side to side hanging bars included.
- Will not line up with 42" high panels.
- To add counterweight (W2 option), add \$200 list.

PRODUCT CODE	PRICE	SIZE/INCHES			WEIGHT VOL	
		H	W	D	LBS	FT ³
EVL30G1830P	1662	39.2	30	18	127.9	14.5
EVL30G1836P	1749	39.2	36	18	147.6	17.2
EVL30G1842P	1849	39.2	42	18	167.5	20.0

EVL40H18xxP • Prime 4 High RFFF Lateral File

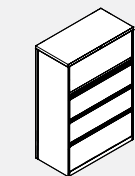

- Four high receding top door and remaining fixed front lateral filing cabinet.
- Top opening receding door + roll out shelf 14.4" front, accepts binder height; fixed front drawers second and third drawers 11.2" (interior 10.6") bottom drawer front 13.6" (interior 12.5").
- Locking.
- Side to side hanging bars included.
- To add counterweight (W2 option), add \$200 list.

PRODUCT CODE	PRICE	SIZE/INCHES			WEIGHT VOL	
		H	W	D	LBS	FT ³
EVL40H1830P	2112	53.6	30	18	171.9	19.6
EVL40H1836P	2226	53.6	36	18	198.2	23.3
EVL40H1842P	2352	53.6	42	18	225.3	27.0

EVL50P18xxP • Prime 5 High RFFFF Lateral File

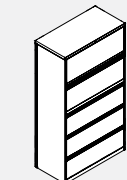

- Five high receding top door and remaining fixed front lateral filing cabinet.
- 13.6" (interior 12.5").
- Locking.
- Side to side hanging bars included.
- Top opening receding door + Roll out shelf 14.4" front, accepts binder height; fixed front drawers below - second and third 11.2" (interior 10.6") bottom drawer front
- To add counterweight (W2 option), add \$200 list.

PRODUCT CODE	PRICE	SIZE/INCHES			WEIGHT VOL	
		H	W	D	LBS	FT ³
EVL50P1830P	2751	65.6	30	18	208.9	23.9
EVL50P1836P	2896	65.6	36	18	239.9	28.4
EVL50P1842P	3061	65.6	42	18	272.7	32.9

EVSC21G18xxP • Prime 2 High Storage Cabinet

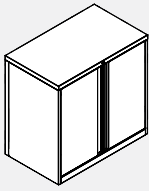

- Two high storage cabinet.
- One adjustable shelf + fixed bottom shelf.
- Locking.

PRODUCT CODE	PRICE	SIZE/INCHES			WEIGHT LBS	VOL FT ³
		H	W	D		
EVSC21G1830P	1040	28	30	18	75.08	10.5
EVSC21G1836P	1161	28	36	18	86.48	12.5
EVSC21G1842P	1262	28	42	18	95.78	14.5

EVSC31G18xxP • Prime 3 High Storage Cabinet

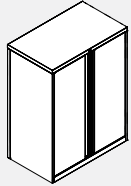

- Three high storage cabinet.
- Two adjustable shelves + fixed bottom shelf.
- Will not line up to 42" high panels.
- Locking.

PRODUCT CODE	PRICE	SIZE/INCHES			WEIGHT LBS	VOL FT ³
		H	W	D		
EVSC31G1830P	1297	39.2	30	18	96.69	14.5
EVSC31G1836P	1459	39.2	36	18	111.59	17.2
EVSC31G1842P	1612	39.2	42	18	124.49	20.0

EVSC41H18xxP • Prime 4 High Storage Cabinet

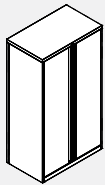

- Four high storage cabinet.
- Three adjustable shelves + fixed bottom shelf.
- Locking.

PRODUCT CODE	PRICE	SIZE/INCHES			WEIGHT LBS	VOL FT ³
		H	W	D		
EVSC41H1830P	1551	53.6	30	18	120.17	19.6
EVSC41H1836P	1734	53.6	36	18	138.27	23.3
EVSC41H1842P	1920	53.6	42	18	154.37	27.0

EVSC51C18xxP • Prime 5 High Storage Cabinet

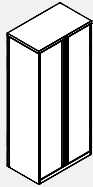

- Five high storage cabinet.
- Four adjustable shelves + fixed bottom shelf.
- Locking.

PRODUCT CODE	PRICE	SIZE/INCHES			WEIGHT LBS	VOL FT ³
		H	W	D		
EVSC51C1830P	1751	65.6	30	18	138.5	23.9
EVSC51C1836P	1961	65.6	36	18	160.4	28.4
EVSC51C1842P	2176	65.6	42	18	180.4	32.9

EVSLFxx24BCPL • Prime Tower, Left Wardrobe, Half Height Door, Box Box File Drawers

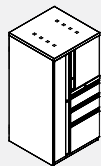

- Left wardrobe tower with half height door and box box file drawers.
- Wardrobe section includes top shelf and coat bar.
- Hinged door compartment of 50"h and 54"h includes one adjustable shelf; 66"h includes two adjustable open shelves.
- Wardrobe section includes top perforations for ventilation.
- Three locks included - wardrobe door, hinged door shelving compartment and drawers.
- To add counterweight (W2 option), add \$105 list.

PRODUCT CODE	PRICE	SIZE/INCHES			WEIGHT LBS	VOL FT ³
		H	W	D		
EVSLF4G24BCPL	2822	49.6	24	24	176.71	19.23
EVSLF4H24BCPL	2836	53.6	24	24	181.63	19.83
EVSLF5024BCPL	2968	65.6	24	24	204.52	25.25

*4G' Tower Shown

EVSLFxx24BCPR • Prime Tower, Right Wardrobe, Half Height Door, Box Box File Drawers

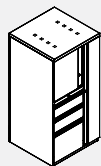

- Right wardrobe tower with half height door and box box file drawers.
- Wardrobe section includes top shelf and coat bar.
- Hinged door compartment of 50"h and 54"h includes one adjustable shelf; 66"h includes two adjustable open shelves.
- Wardrobe section includes top perforations for ventilation.
- Three locks included - wardrobe door, hinged door shelving compartment and drawers.
- To add counterweight (W2 option), add \$105 list.

PRODUCT CODE	PRICE	SIZE/INCHES			WEIGHT LBS	VOL FT ³
		H	W	D		
EVSLF4G24BCPR	2822	49.6	24	24	176.71	19.23
EVSLF4H24BCPR	2836	53.6	24	24	181.63	19.83
EVSLF5024BCPR	2968	65.6	24	24	204.52	25.25

*4G' Tower Shown

EVSLFxx24FCPL • Prime Tower, Left Wardrobe, Half Height Door, File File Drawers

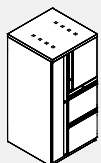

- Left wardrobe tower with half height door and file file drawers.
- Wardrobe section includes top shelf and coat bar.
- Hinged door compartment of 50"h and 54"h includes one adjustable shelf; 66"h includes two adjustable open shelves.
- Wardrobe section includes top perforations for ventilation.
- Three locks included - wardrobe door, hinged door shelving compartment and drawers.
- To add counterweight (W2 option), add \$105 list.

PRODUCT CODE	PRICE	SIZE/INCHES			WEIGHT LBS	VOL FT ³
		H	W	D		
EVSLF4G24FCPL	2822	49.6	24	24	181.05	19.23
EVSLF4H24FCPL	2836	53.6	24	24	186.43	19.83
EVSLF5024FCPL	2968	65.6	24	24	231.53	25.25

*4G' Tower Shown

EVSLFxx24FCPR • Prime Tower, Right Wardrobe, Half Height Door, File File Drawers

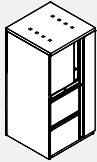

*4G' Tower Shown

- Right wardrobe tower with half height door and file file drawers.
- Wardrobe section includes top shelf and coat bar.
- Hinged door compartment of 50" h and 54" h includes one adjustable shelf; 66" h includes two adjustable open shelves.
- Wardrobe section includes top perforations for ventilation.
- Three locks included - wardrobe door, hinged door shelving compartment and drawers.
- To add counterweight (W2 option), add \$105 list.

PRODUCT CODE	PRICE	SIZE/INCHES			WEIGHT LBS	VOL FT ³
		H	W	D		
EVSLF4G24FCPR	2822	49.6	24	24	181.05	19.23
EVSLF4H24FCPR	2836	53.6	24	24	186.43	19.83
EVSLF5024FCPR	2968	65.6	24	24	231.53	25.25

EVSLSxx2424BOPL • Prime Tower, Left Wardrobe, Side Open Shelf, Box Box File Drawers

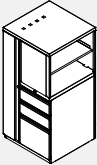

*4G' Tower Shown

- Left wardrobe tower with side open shelving and box box file drawers.
- Wardrobe section includes top shelf and coat bar.
- 50" h and 54" h include open side shelf with one adjustable shelf; 66" h includes open side shelf with two adjustable shelves.
- Wardrobe section includes top perforations for ventilation.
- Two locks included - wardrobe door and drawers.

PRODUCT CODE	PRICE	SIZE/INCHES			WEIGHT LBS	VOL FT ³
		H	W	D		
EVSLS4G2424BOPL	3117	49.6	24	24	186.18	19.23
EVSLS4H2424BOPL	3135	53.6	24	24	186.91	19.83
EVSLS502424BOPL	3131	65.6	24	24	236.34	25.25

EVSLSxx2424BOPR • Prime Tower, Right Wardrobe, Side Open Shelf, Box Box File Drawers

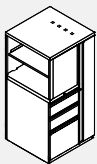

*4G' Tower Shown

- Right wardrobe tower with side open shelving and box box file drawers.
- Wardrobe section includes top shelf and coat bar.
- 50" h and 54" h include open side shelf with one adjustable shelf; 66" h includes open side shelf with two adjustable shelves.
- Wardrobe section includes top perforations for ventilation.
- Two locks included - wardrobe door and drawers.

PRODUCT CODE	PRICE	SIZE/INCHES			WEIGHT LBS	VOL FT ³
		H	W	D		
EVSLS4G2424BOPR	3117	49.6	24	24	186.18	19.23
EVSLS4H2424BOPR	3135	53.6	24	24	186.91	19.83
EVSLS502424BOPR	3131	65.6	24	24	236.34	25.25

EVSLSxx2424FOPL • Prime Tower, Left Wardrobe, Side Open Shelf, File File Drawers

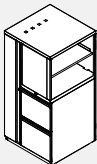

*4G' Tower Shown

- Left wardrobe tower with side open shelving and file file drawers.
- Wardrobe section includes top shelf and coat bar.
- 50" h and 54" h include open side shelf with one adjustable shelf; 66" h includes open side shelf with two adjustable shelves.
- Wardrobe section includes top perforations for ventilation.
- Two locks included - wardrobe door and drawers.

PRODUCT CODE	PRICE	SIZE/INCHES			WEIGHT LBS	VOL FT ³
		H	W	D		
EVSLS4G2424FOPL	3117	49.6	24	24	179.54	19.23
EVSLS4H2424FOPL	3135	53.6	24	24	180.26	19.83
EVSLS502424FOPL	3131	65.6	24	24	232.55	25.25

EVSLSxx2424FOPR • Prime Tower, Right Wardrobe, Side Open Shelf, File File Drawers

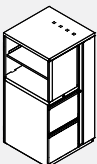

*4G' Tower Shown

- Right wardrobe tower with side open shelving and file file drawers.
- Wardrobe section includes top shelf and coat bar.
- 50" h and 54" h include open side shelf with one adjustable shelf; 66" h includes open side shelf with two adjustable shelves.
- Wardrobe section includes top perforations for ventilation.
- Two locks included - wardrobe door and drawers.

PRODUCT CODE	PRICE	SIZE/INCHES			WEIGHT LBS	VOL FT ³
		H	W	D		
EVSLS4G2424FOPR	3117	49.6	24	24	179.54	19.23
EVSLS4H2424FOPR	3135	53.6	24	24	180.26	19.83
EVSLS502424FOPR	3131	65.6	24	24	232.55	25.25

EVWC51C18xxP • Prime Wardrobe

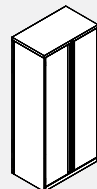

- Wardrobe cabinet.
- 30"W includes full width shelf and side to side coat rod.
- 36" and 42"W are split with shelving on left side, wardrobe on the other.

PRODUCT CODE	PRICE	SIZE/INCHES			WEIGHT LBS	VOL FT ³
		H	W	D		
EVWC51C1830P	1789	65.6	30	18	125.26	23.85
EVWC51C1836P	1998	65.6	36	18	164.97	28.40
EVWC51C1842P	2198	65.6	42	18	180.59	32.94

EVCC31G18xxP • Prime Three High Combination Cabinet

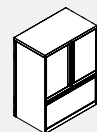

- Multi stor cabinet including hinged door upper section with one adjustable shelf; one fixed front file drawers below.
- Will not line up to 42" high panels.
- Locking.

PRODUCT CODE	PRICE	SIZE/INCHES			WEIGHT LBS	VOL FT ³
		H	W	D		
EVCC31G1830P	2227	39.2	30	18	117.3	14.5
EVCC31G1836P	2426	39.2	36	18	135.5	17.2
EVCC31G1842P	2635	39.2	42	18	152.5	20.0

EVCC41G18xxP • Prime Four High Combination Cabinet

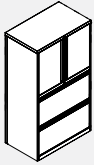

- Multi stor cabinet including hinged door upper section with one adjustable shelf; two fixed front file drawers below, lines up to 50" high panels.
- Locking.
- To add counterweight (W2 option), add \$200 list.

PRODUCT CODE	PRICE	SIZE/INCHES			WEIGHT LBS	VOL FT ³
		H	W	D		
EVCC41G1830P	2665	49.6	30	18	149.96	18.2
EVCC41G1836P	2853	49.6	36	18	172.96	21.6
EVCC41G1842P	3072	49.6	42	18	195.36	25.1

EVCC41H18xxP • Prime Four High Combination Cabinet

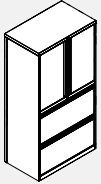

- Multi stor cabinet including hinged door upper section with one adjustable shelf; two fixed front file drawers below, lines up to 54" high panels.
- Locking.
- To add counterweight (W2 option), add \$200 list.

PRODUCT CODE	PRICE	SIZE/INCHES			WEIGHT LBS	VOL FT ³
		H	W	D		
EVCC41H1830P	2796	53.6	30	18	154.54	19.6
EVCC41H1836P	2992	53.6	36	18	178.54	23.3
EVCC41H1842P	3225	53.6	42	18	202.04	27.0

EVCC31C18xxP • Prime Five High Combination Cabinet

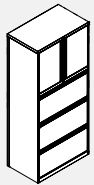

- Multi stor cabinet including hinged door upper section with one adjustable shelf; three fixed front file drawers below.
- Locking.
- To add counterweight (W2 option), add \$200 list.

PRODUCT CODE	PRICE	SIZE/INCHES			WEIGHT LBS	VOL FT ³
		H	W	D		
EVCC51C1830P	3083	65.6	30	18	188.5	23.9
EVCC51C1836P	3344	65.6	36	18	216.9	28.4
EVCC51C1842P	3581	65.6	42	18	245.5	32.9

EVLFA0718 • Prime Front to Back File Bars

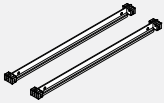

- Package of two, grey finish.

PRODUCT CODE	PRICE	SIZE/INCHES			WEIGHT LBS	VOL FT ³
		H	W	D		
EVLFA0718	28	1	17.3	1	1	0.04

EVLFS • Prime Hanging File Bars

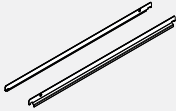

- Package of two, grey finish.

PRODUCT CODE	PRICE	SIZE/INCHES			WEIGHT LBS	VOL FT ³
		H	W	D		
EVLFA01	48	1.3	27.5	0.5	2	0.03
EVLFA02	48	1.3	33.5	0.5	2.4	0.04
EVLFA03	48	1.3	39.5	0.5	2.8	0.05

EVLFA1018 • Prime Plate Dividers

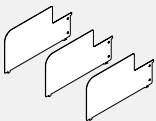

- Package of three, grey finish.

PRODUCT CODE	PRICE	SIZE/INCHES			WEIGHT LBS	VOL FT ³
		H	W	D		
EVLFA1018	61	7.25	13.5	0.2	4	0.07

EVLFA2418 • Prime Half Height Plate Dividers

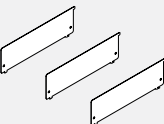

- Package of three, grey finish.

PRODUCT CODE	PRICE	SIZE/INCHES			WEIGHT LBS	VOL FT ³
		H	W	D		
EVLFA2418	45	3.95	13.5	0.2	2.2	0.04

EVLFA2018 • Prime EDP Adapters

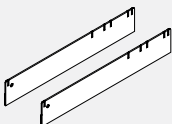

PRODUCT CODE	PRICE	SIZE/INCHES			WEIGHT LBS	VOL FT ³
		H	W	D		
EVLFA2018	51	2.6	16.5	0.15	2.5	0.02

EVK • Keys and Replacement Lock Core

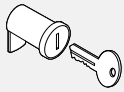

- Set of Extra Keys.
- Replacement Lock and Key.

PRODUCT CODE	PRICE	SIZE/INCHES			WEIGHT LBS	VOL FT ³
		H	W	D		
EVKY EXTRA KEY	14	1.75	0.75	0.2	0.2	0.01
EVKC LOCK & KEY	41	2	1	0.5	0.4	0.01

EVSA • Prime Extra Cabinet Shelves

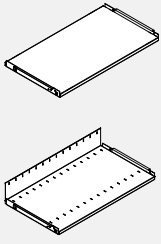

- Shelf, non-slotted.
- Shelf, slotted.

PRODUCT CODE	PRICE	SIZE/INCHES			WEIGHT LBS	VOL FT ³
		H	W	D		
Shelf, non-slotted.						
EVSA011830	141	0.8	28.4	16	7.2	0.4
EVSA011836	147	0.8	34.4	16	8.4	0.5
EVSA011842	155	0.8	40.4	16	9.5	0.6
Shelf, slotted.						
EVSA021830	154	5.25	28.4	16	8.2	1.8
EVSA021836	160	5.25	34.4	16	9.6	2.2
EVSA021842	176	5.25	40.4	16	10.8	2.6

EVHPB6 - Worksurface Supporting 9300 Pedestal Bracket



- Attaches to back edge of a pedestal and connects pedestal to panel connector.

PRODUCT CODE	PRICE	SIZE/INCHES	WEIGHT LBS	VOL FT ³
EVHPB6	28	13.5 1 1	0.5	0.5

EVHPB5 - Worksurface Supporting Pedestal Bracket and Filler For Prime



- Attaches to back edge of a pedestal and connects pedestal to panel connector.

PRODUCT CODE	PRICE	SIZE/INCHES	WEIGHT LBS	VOL FT ³
EVHPB5	28	28 1 2	0.5	0.5

EVALB • Load Bar

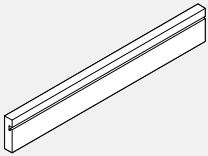

- Enables accessory items to be hung from a panel or wall.
- Includes end caps and mounting brackets.

PRODUCT CODE	PRICE	SIZE/INCHES	
		H	W D
EVALB24	133	2.25	24 1
EVALB30	146	2.25	30 1
EVALB36	161	2.25	36 1
EVALB42	187	2.25	42 1
EVALB48	213	2.25	48 1
EVALB54	234	2.25	54 1
EVALB60	247	2.25	60 1

EVALB2 • Ganging Load Bar - Top

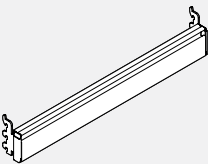

- Enables accessory items to be hung from a panel or wall.
- Includes end caps and mounting brackets.
- Can connect to EVALB2-2 and/or EVALB2-3 Load Bars to create a multi-level bar or "Slat Wall" or can be used on its own.

PRODUCT CODE	PRICE	SIZE/INCHES	
		H	W D
EVALB224	104	2.25	24 1
EVALB230	112	2.25	30 1
EVALB236	116	2.25	36 1
EVALB242	124	2.25	42 1
EVALB248	131	2.25	48 1
EVALB254	134	2.25	54 1
EVALB260	139	2.25	60 1

EVALB22 • Ganging Load Bar - Middle

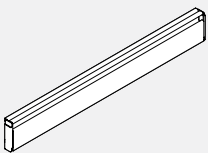

- Enables accessory items to be hung from a panel or wall.
- Includes end caps and is to be used in conjunction with the Ganging Load Bar-Top (EVALB) mounting brackets NOT included.
- Can connect to EVALB2 and/or EVALB2-3 Load Bars to create a multi-level bar or "Slat Wall". Multiples of EVALB2-2 can be joined one below the other to create the "Slat Wall".
- Must be used on conjunction with an EVALB2 or a combination of EVALB2 and EVALB2-3.

PRODUCT CODE	PRICE	SIZE/INCHES	
		H	W D
EVALB2-224	69	2.25	24 1
EVALB2-230	77	2.25	30 1
EVALB2-236	81	2.25	36 1
EVALB2-242	90	2.25	42 1
EVALB2-248	94	2.25	48 1
EVALB2-254	102	2.25	54 1
EVALB2-260	106	2.25	60 1

EVALB23 • Ganging Load Bar - Bottom

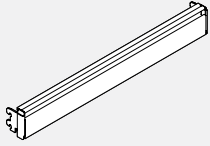

- Enables accessory items to be hung from a panel or wall.
- Includes end caps and mounting brackets.
- Must connect to EVALB2 and/or EVALB2-3 Load Bars to create a multi-level bar or "Slat Wall".
- Must be used on conjunction with an EVALB2 or a combination of EVALB2 and EVALB2-2.

PRODUCT CODE	PRICE	SIZE/ INCHES		
		H	W	D
EVALB2-324	102	2.25	24	1
EVALB2-330	106	2.25	30	1
EVALB2-336	112	2.25	36	1
EVALB2-342	116	2.25	42	1
EVALB2-348	126	2.25	48	1
EVALB2-354	132	2.25	54	1
EVALB2-360	136	2.25	60	1

EVACH01 • Coat Hook

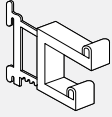

- Panel mounted coat hook.**
- Panel frame finish
 - Not available in Fog (FOG)
 - Not available in Metal Paper Accessory Colours

PRODUCT CODE	PRICE	SIZE/ INCHES			WEIGHT VOL	
		H	W	D	LBS	FT ³
EVACH01	69	3	0.75	3	0.2	0.001

EVACH02 • Panel Coat Hook

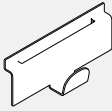

- Panel mounted coat hook.**
- Installed at panel top in groove between module and top trim.
 - Available in standard and premium paint colors.
 - Priced per six piece package.

PRODUCT CODE	PRICE	SIZE/ INCHES			WEIGHT VOL	
		H	W	D	LBS	FT ³
EVACH02	92	1	2.5	0.625	0.8	0.01

EVANP02 • Name Plate

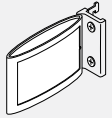

- Name plate attaches to 1" increment slots of Evolve. It can be set either as a single-sided (parallel to panel surface) or double-sided (perpendicular to panel surface - for isle applications, displaying name on both sides).
- Injection molded frame and die-cast base with **black rubberized finish**.
- Steel bracket and fasteners included
- Includes two slide-in name cards.

PRODUCT CODE	PRICE	SIZE/ INCHES			WEIGHT VOL	
		H	W	D	LBS	FT ³
EVANP02	89	3.3	5.3	1.25	0.3	0.013

EVATB • Fabric Tackboard

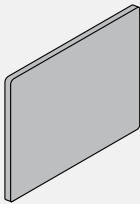

- To provide a tackable surface for notes and memos in a work area. Panel mounted.**
- Includes set of 4 mounting brackets.
 - Class "A" Fire Rated Fabric.

PRODUCT CODE	PRICE		SIZE/ INCHES			WEIGHT VOL	
	GR1	GR2	H	W	D	LBS	FT ³
EVATB1730	261	274	17	30	0.25	3	0.416
EVATB1736	298	312	17	36	0.25	4	0.500
EVATB1742	340	353	17	42	0.25	4	0.583
EVATB1748	378	397	17	48	0.25	5	0.666
EVATB1754	419	441	17	54	0.25	5	0.750
EVATB1760	460	483	17	60	0.25	6	0.833
EVATB2130	261	270	21	30	0.25	3	0.416
EVATB2136	298	307	21	36	0.25	4	0.500
EVATB2142	340	351	21	42	0.25	4	0.583
EVATB2148	378	392	21	48	0.25	5	0.666
EVATB2154	419	439	21	54	0.25	5	0.750
EVATB2160	460	482	21	60	0.25	6	0.833
EVATB2430	261	271	24	30	0.25	3	0.416
EVATB2436	298	312	24	36	0.25	4	0.500
EVATB2442	352	378	24	42	0.25	4	0.583
EVATB2448	394	419	24	48	0.25	5	0.666
EVATB2454	441	509	24	52	0.25	5	0.750
EVATB2460	460	482	24	60	0.25	6	0.833

EVHTVM • TV Mount

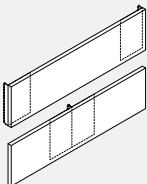

- Laminate panel with two mounting brackets to be installed on Evolve panels.
- TV Mount can be installed on panel of equal width or both brackets can be attached in middle for installing on single connector.
- TV frame not included, TV frame to be ordered separately.
- Note: TV frame must be securely attach to laminate panel. Care should be taken to attach TV frame using correct fasteners.
- Failure to do so may result in collapse of unit and subsequent possible injury.

PRODUCT CODE	PRICE	SIZE/ INCHES			WEIGHT LBS	VOL FT ³
		H	W	D		
EVHTVM24	173	11	24	1.0	14.00	0.46
EVHTVM30	190	11	30	1.0	17.00	0.52
EVHTVM36	204	11	36	1.0	19.00	0.60
EVHTVM42	219	11	42	1.0	22.00	0.68

EVPMPS42 • Privacy Mesh Divider

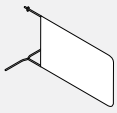

- **Divider attaches to connector.**
- Available with Visionknit mesh only.
- Current available (others available upon request)
GRY Grey
BOR Burnt Orange
- Wire frame upholstered in Visionknit mesh.
- Visionknit mesh easy to replace.
- Wire frame painted in standard paint finishes.
- For each mesh colour ordered, minimum order must be 25 pcs.
- If mesh colour ordered is less than 25 pcs, there will be upcharge fee \$132 net per each mesh colour.
- Note: Divider can be only used with 42" h. segmented panels (24" bottom and 12" top module configuration only).
- Divider attaches to top 12" module.

PRODUCT CODE	PRICE	SIZE/ H	INCHES W	D	WEIGHT LBS	VOL FT ³
EVPMPS42	157	12	24	0.250	5	0.416

EVAWB • Write Board

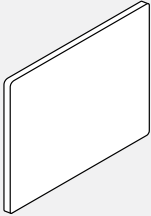

- **To provide a writing surface in a work area. Panel mounted.**
- Includes set of 4 mounting brackets.
- Black trim only

PRODUCT CODE	PRICE	SIZE/ H	INCHES W	WEIGHT LBS	VOL FT ³
EVAWB2130	293	21	30	3	0.416
EVAWB2136	333	21	36	4	0.500
EVAWB2142	372	21	42	4	0.588
EVAWB2148	433	21	48	5	0.833
EVAWB2430	293	24	30	3	0.416
EVAWB2436	333	24	36	4	0.500
EVAWB2442	372	24	42	4	0.588
EVAWB2448	433	24	48	5	0.833

EVAMT • Marker Tray

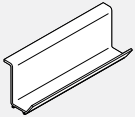

- **Provides a tray for storage of markers, erasers. etc.**
- Attaches to the bottom of the White Marker Board.

PRODUCT CODE	PRICE	SIZE/ W	INCHES H	WEIGHT LBS	VOL FT ³
EVAMT12	16	12	0.5	0.01	

EVSOFD • Overhead Divider



- **Attaches to EVS0F12 or EVS0F13 Overhead top shelf inside the overhead.**
- Provides a rigid division for books and binders.
- Sold per pair.

PRODUCT CODE	PRICE	SIZE/ H	INCHES W	WEIGHT LBS	VOL FT ³
EVSOFD01	58	10	0.1875	0.8	0.02

EVAOMFD • Dry Erase Marker Board

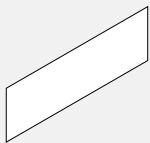

- **Adheres magnetically to the door fo a flipper door overhead.**

PRODUCT CODE	PRICE	SIZE/ H	INCHES W	D
EVAOMFD24	227	14.4	22.8	0.05
EVAOMFD30	261	14.4	28.8	0.05
EVAOMFD36	299	14.4	34.8	0.05
EVAOMFD42	341	14.4	40.8	0.05
EVAOMFD48	373	14.4	46.8	0.05
EVAOMFD54	391	14.4	52.8	0.05
EVAOMFD60	422	14.4	58.8	0.05

EVAOMBW • Dry Erase Marker Board

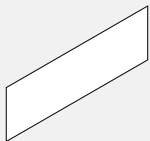

- **Adheres magnetically to the back wall of the AODA Overhead.**

PRODUCT CODE	PRICE	SIZE/ H	INCHES W	D
EVAOMBW30	261	14.4	29.2	0.05
EVAOMBW36	299	14.4	35.5	0.05
EVAOMBW42	341	14.4	41.2	0.05
EVAOMBW48	373	14.4	47.2	0.05
EVAOMBW54	391	14.4	53.2	0.05
EVAOMBW60	422	14.4	59.2	0.05

EVED50AC • Duo Module with A+C

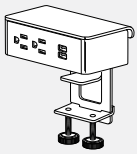

- The Duo power module is completely integrated with a mounting clamp to attach to the edge of a worksurface.
- Provides two 15 Amp 120 Volt AC Receptacles; 2.4 amp USB-A port and 60 watt USB-C power delivery port.
- 10' long three-prong cord.
- Available in W - White or B - Black as indicated by last letter of model number.

PRODUIT CODE	PRIX	TAILLE/ POUCES			POIDS		VOLUME
		H	L	P	LB	PI ³	
EVED50ACW	695	3	5.5	3.2	3	0.2	
EVED50ACB	695	3	5.5	3.2	3	0.2	

EVEDU51AC • Duo Under Module

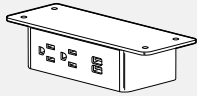

- The Duo under power module comes with a thin flush mounting bracket to attach to the underside of a work surface or above work surface shelves.
- Provides two 15 Amp 120 Volt AC Receptacles; 2.4 amp USB-A port and 60 watt USB-C power delivery port.
- 10' long three-prong cord.
- Available in W - White or B - Black as indicated by last letter of model number.

PRODUIT CODE	PRIX	TAILLE/ POUCES			POIDS		VOLUME
		H	L	P	LB	PI ³	
EVEDU51ACW	695	1.8	5.5	2.8	3	0.2	
EVEDU51ACB	695	1.8	5.5	2.8	3	0.2	

EVMA1 • Single Clamp Mount Monitor Arm

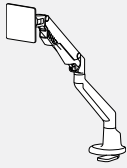

- Finger touch dynamic height adjustment, 12" height range. 4.4 to 19.8 lbs. per monitor loading capacity; accepts screen size 17"-30".
- Maximum monitor width of 34".
- Maximum of 20.5" extension from rear of desk to back of monitor, folds to 4.5".
- Tilt, pan and landscape to portrait rotation; quick release VESA plate, 180 degree lock out.
- Clamp mount and grommet mount options included, accommodates 0.5" to 2" thick tops.
- Accepts mini slide arm GAMS.
- Available in TUN - Tungsten only.

PRODUIT CODE	PRICE	SIZE/ H	INCHES			WEIGHT VOL	
			W	D	LBS	FT ³	
EVMA1	460	21		5.5	6.6	0.4	

EVMA2 • Double Clamp Mount Monitor Arm

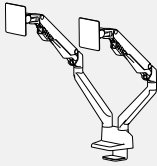

- Finger touch dynamic height adjustment, 12" height range.
- 4.4 to 19.8 lbs. per monitor loading capacity; accepts screen size 17"-30".
- Maximum monitor width of 34".
- Maximum of 20.5" extension from rear of desk to back of monitor, folds to 4.5".
- Tilt, pan and landscape to portrait rotation; quick release VESA plate, 180 degree lock out.
- Clamp mount and grommet mount options included, accommodates 0.5" to 2" thick tops.
- Accepts mini slide arm GAMS.
- Available in TUN - Tungsten only.

PRODUIT CODE	PRICE	SIZE/ H	INCHES			WEIGHT VOL	
			W	D	LBS	FT ³	
EVMA2	807	21		5.5	12.8	1	

EVAMS • Mini Slide Monitor Arm

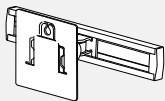

- Works with GAMA1 and GAMA2 monitor arms.
- 9" slide, loading capacity 13.2lbs.
- Quick release VESA plate.
- Available in TUN - Tungsten only.

PRODUIT CODE	PRICE	SIZE/ H	INCHES			WEIGHT VOL	
			W	D	LBS	FT ³	
EVAMS	160	4.5	11	6	3.3	0.3	

EVELEDVS • LED Single Arm Lamp



- 7 System watts, 18-fractional LEDs.
- 3500K 250 lumens, 84CRI.
- Soft touch - instant on, fade to off.
- Infinite dimming 100% down to 15%, last state memory.
- Standard 10 hours turn off (ATO).
- 50,000 hour life LEDs.
- 15 watt, 24 volt wall transformer, 6' cord.
- White (WHT) or Black (BLK) - Must specify colour choice.

PRODUCT CODE	PRICE	SIZE/ INCHES			WEIGHT VOL	
		H	W	D	LBS	FT ³
EVELEDVS	616	8	7	33	7.3	0.98
With occupancy sensor						
EVELEDVSO	920	10	9	35	8.3	1.51

- UL, CUL and CSA compliant, ETL Listed.
- Base not included.

EVELEDVD • LED Double Arm Lamp

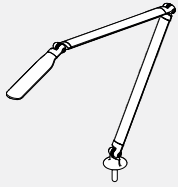

- 7 System watts, 18-fractional LEDs.
- 3500K 250 lumens, 84CRI.
- Double arm articulation with 20" base to head reaches.
- Soft touch - instant on, fade to off.
- Infinite dimming 100% down to 15%, last state memory.
- Standard 10 hours turn off (ATO).
- 50,000 hour life LEDs.
- 15 watt, 24 volt wall transformer, 6' cord.
- White (WHT) or Black (BLK) - Must specify colour choice.

PRODUCT CODE	PRICE	SIZE/ INCHES			WEIGHT VOL	
		H	W	D	LBS	FT ³
EVELEDVD	633	8	7	33	7.6	1.02
With occupancy sensor						
EVELEDVDO	931	10	9	35	8.6	1.57

- UL, CUL and CSA compliant, ETL Listed.
- Base not included.

EVELEDRS • LED Single Arm Lamp

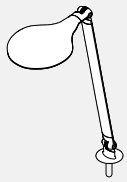

- 7 System watts, 18-fractional LEDs.
- 3500K 250 lumens, 84CRI.
- Soft touch - instant on, fade to off.
- Infinite dimming 100% down to 15%, last state memory.
- Standard 10 hours turn off (ATO).
- 50,000 hour life LEDs.
- 15 watt, 24 volt wall transformer, 6' cord.
- White (WHT) or Black (BLK) - Must specify colour choice.

PRODUCT CODE	PRICE	SIZE/ INCHES			WEIGHT VOL	
		H	W	D	LBS	FT ³
EVELEDRS	616	8	7	33	7.3	0.98
With occupancy sensor						
EVELEDRSO	920	10	9	35	8.3	1.51

- UL, CUL and CSA compliant, ETL Listed.
- Base not included.

EVELEDRD • LED Double Arm Lamp



- 7 System watts, 18-fractional LEDs.
- 3500K 250 lumens, 84CRI.
- Double arm articulation with 20" base to head reaches.
- Soft touch - instant on, fade to off.
- Infinite dimming 100% down to 15%, last state memory.
- Standard 10 hours turn off (ATO).
- 50,000 hour life LEDs.
- 15 watt, 24volt wall transformer, 6' cord.
- White (WHT) or Black (BLK) - Must specify colour choice.

PRODUCT CODE	PRICE	SIZE/ INCHES			WEIGHT VOL	
		H	W	D	LBS	FT ³
EVELEDRD	633	8	7	33	7.6	1.02
With occupancy sensor						
EVELEDRDO	931	10	9	35	8.6	1.57

- UL, CUL and CSA compliant, ETL Listed.
- Base not included.

Lamp Mounting Options



Grommet Mount

PRODUCT CODE	PRICE	SIZE/ INCHES	WEIGHT VOL			
		H	W	D	LBS	FT ³
EVELEDASM	155	3	6	6	3	0.06



Worksurface Mount

PRODUCT CODE	PRICE	SIZE/ INCHES	WEIGHT VOL			
		H	W	D	LBS	FT ³
EVELEDACM	155	3	6	6	2	0.04



Slatwall Mount

PRODUCT CODE	PRICE	SIZE/ INCHES	WEIGHT VOL			
		H	W	D	LBS	FT ³
EVELEDASW	155	3	6	6	3	0.06



Panel Mount

PRODUCT CODE	PRICE	SIZE/ INCHES	WEIGHT VOL			
		H	W	D	LBS	FT ³
EVELEDAPM	155	3	6	6	3	0.06

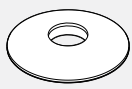

Weighted Base

PRODUCT CODE	PRICE	SIZE/ INCHES	WEIGHT VOL			
		H	W	D	LBS	FT ³
EVELEDAFS	173	4	12	12	6	0.50

EVABB01 • Binder Bin



- Load bar/accessory rail mounted metal binder bin.
- Panel frame finish

PRODUCT CODE	PRICE	SIZE/ INCHES			WEIGHT VOL	
		H	W	D	LBS	FT ³
EVABB01	58	9	5.75	9.25	1.85	0.21

EVAFS01 • Flip Sorter



- Load bar/accessory rail mounted metal flip sorter. Comes with nickel plated wire.
- Panel frame finish

PRODUCT CODE	PRICE	SIZE/ INCHES			WEIGHT VOL	
		H	W	D	LBS	FT ³
EVAFS01	40	9	3	9	0.6	0.14

EVASS01 • Slant Sorter

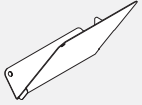

Right hand Shown

- Load bar/accessory rail mounted metal slant sorter.
- Panel frame finish

PRODUCT CODE	PRICE	SIZE/ INCHES			WEIGHT VOL	
		H	W	D	LBS	FT ³
EVASS01R	35	9.25	2.75	9	1	0.28
EVASS01L	35	9.25	2.75	9	1	0.28

EVALT01 • Letter Tray

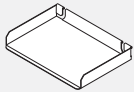

- Load bar/accessory rail mounted metal letter tray.
- Panel frame finish

PRODUCT CODE	PRICE	SIZE/ INCHES			WEIGHT VOL	
		H	W	D	LBS	FT ³
EVALT01	43	1.75	12	8.75	0.5	0.15

EVALT02 • Legal Tray

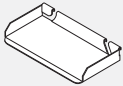

- Load bar/accessory rail mounted metal legal tray.
- Panel frame finish

PRODUCT CODE	PRICE	SIZE/ INCHES			WEIGHT VOL	
		H	W	D	LBS	FT ³
EVALT02	58	1.75	14.7	8.75	0.5	0.15

EVAMB01 • Media Bin

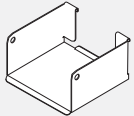

- Load bar/accessory rail mounted.
- Panel frame finish

PRODUCT CODE	PRICE	SIZE/ INCHES			WEIGHT VOL	
		H	W	D	LBS	FT ³
EVAMB01	43	3	5.75	5.25	0.8	0.05

EVAUT01 • Utility Tray

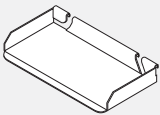

- Load bar/accessory rail mounted metal utility tray.
- Panel frame finish

PRODUCT CODE	PRICE	SIZE/ INCHES			WEIGHT VOL	
		H	W	D	LBS	FT ³
EVAUT01	30	1	7.5	3.75	0.5	0.02

EVAPP01 • Mail Box

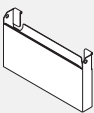

- Load bar/accessory rail mounted.
- Panel frame finish

PRODUCT CODE	PRICE	SIZE/ INCHES			WEIGHT VOL	
		H	W	D	LBS	FT ³
EVAPP01	72	7	12	1.75	2	0.25

EVATH01 • Telephone Holder

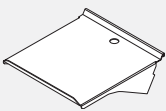

- Load bar/rail mounted telephone holder.
- Panel frame finish

PRODUCT CODE	PRICE	SIZE/ INCHES			WEIGHT VOL	
		H	W	D	LBS	FT ³
EVATH01	68	2	8	10	2	0.26

EVPFD-WS • Worksurface Felt Divider

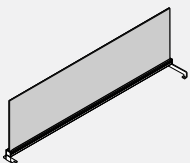

- Privacy felt divider integrated into an aluminum top trim.
- Attaches on top of a worksurface to add privacy or divide space.
- Must be used at connector location.
- Includes aluminum trim with channel, felt tile and brackets.
- 9 mm felt material is tackable and comes in 18 different colors. Please specify felt finish.
- Aluminum extrusion and brackets available in standard paint finishes.
- Felt tile and attachment hardware to ship separately.

PRODUCT CODE	PRICE	SIZE/ INCHES			WEIGHT VOL	
		H	W	D	LBS	FT ³
EVPFD1818WS	158	18	18	1	2.26	0.75
EVPFD1824WS	177	18	24	1	2.77	0.94
EVPFD1830WS	199	18	30	1	3.29	1.13
EVPFD1836WS	216	18	36	1	3.8	1.31

PRIVA NOTES

GENERAL INFORMATION

- Priva™ acoustic pods provide a place for personal privacy, focus and online collaboration, away from the commotion of the open office.
- Integrated ventilation (55 cubic feet per minute) and low-voltage LED lighting are motion-sensor activated to reduce energy consumption while providing a comfortable environment for short or longer stays.
- The tempered glass entrance door, in combination with an optional glass back panel, reduces the sense of confinement.

CONSTRUCTION

- Assembles in less than 90 minutes. Once complete, simply plug in and get to work!
- Priva has been tested and complies with all BIFMA mechanical tests.
- Exterior is clad in 3/4" thermally fused laminate with a 10mm tempered glass door and glass (POD1G, POD2G, POD3G) or laminate back panel (POD1L).
- Exterior corner details are made of extruded aluminum
- Internal frame is comprised of 14 gauge steel beams
- Interior is clad in PET (recommended for greater acoustic properties)
- Laminate interior is optional.
- Pod ceiling is Designer White laminate
- Interior carpet flooring is comprised of eco-friendly Nylon fiber, solution dyed with a polypropylene backing.
- Laminate touch-down shelf is standard in Designer White (DWT) laminate.

DIMENSIONS

- Door: 32" w x 88" h
- Shelf: 24" w x 8" d x 40" h
- Electrical cord is 10' long.

Exterior Laminate Finishes

Absolute Acajou	ACJ
Asian Night	ASN
Black	BLK
Brushed Cobalt	BRC
Clear Maple	CMB
Dark Espresso	DES
Designer White	DWT
Noce Biondo	NBL
Noce Grigio	NGL
Noce Leggero	NEL
Noce Medio	NML
Storm Grey	SOG
Walnut Heights	WHE
White Chocolate	WHC
Winter Cherry	WCR

Exterior Frame Finishes

Black	BLK
Charcoal	CHR
Designer White	DWT
Tungsten	TUN

Hardware Finishes (Handle + Hinge)

Black	BK
Silver	SI

Interior Finishes - Select Laminate or PET

PET

Graphite	GPH
Pewter	PWT
Mist	MTS

Laminate

Black	BLK
Designer White	DWT
Storm Grey	SOG

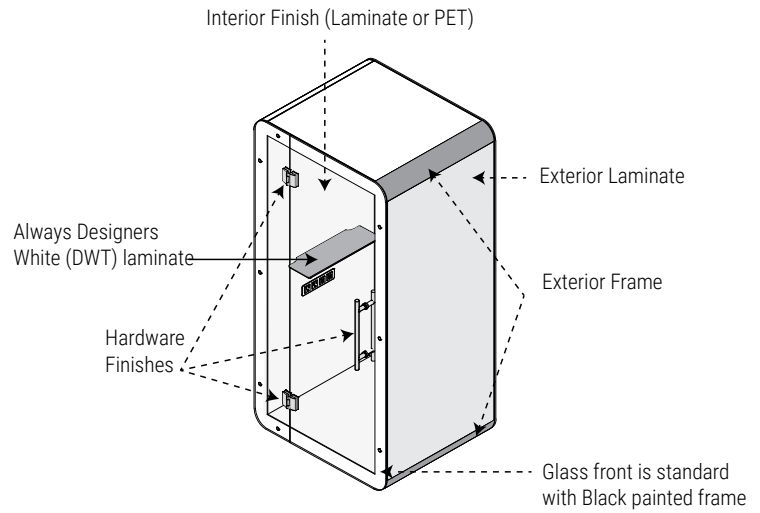

Exterior Dimensions

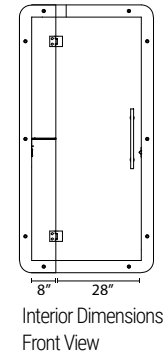
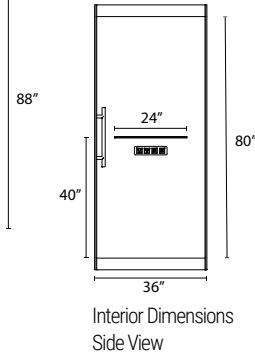
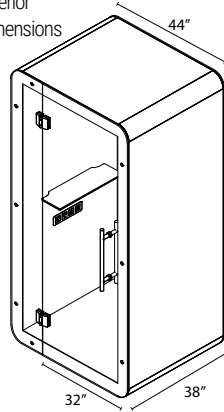

Exterior Dimensions

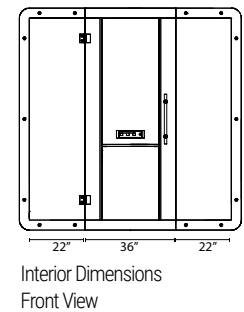
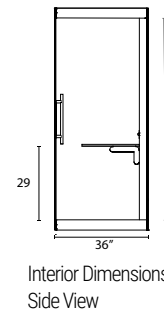
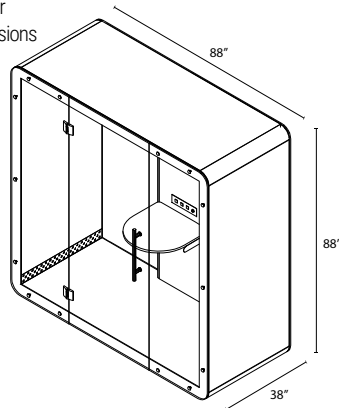

Exterior Dimensions

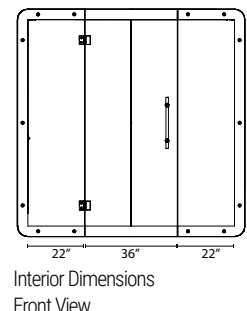
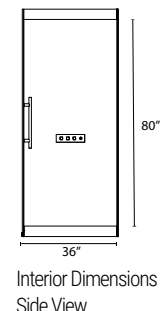
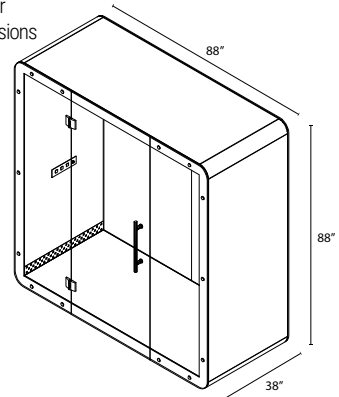

POD1G • Single User Pod - Glass Back Panel

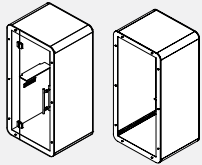

Front View/Rear View

- Acoustic Pod includes laminate exterior with aluminum frame. PET interior provides acoustic privacy.
- Laminate interior optional for easy cleaning. Door is 10mm tempered glass with a glass back panel.
- Power + Connectivity: 2 AC outlets and 2 charging USB-A ports coupled with an occupancy sensor controlling two 12V DC fans and an LED light circuit, ensuring comfort in even the smallest of enclosed spaces, while keeping power consumption at a minimum.
- Acoustic Ratings: NIC-36, STI .07
- Airflow Specifications: CFM 55

PRODUCT CODE	PRICE	SIZE/INCHES			WEIGHT LBS	VOL FT ³
		H	W	D		
POD1G	25852	88	44	38	800	85

POD1L • Single User Pod - Laminate Back Panel

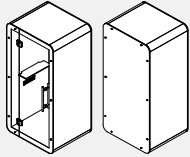

Front View/Rear View

- Acoustic Pod includes laminate exterior with aluminum frame. PET interior provides acoustic privacy.
- Laminate interior optional for easy cleaning. Door is 10mm tempered glass with a laminate back panel.
- Power + Connectivity: 2 AC outlets and 2 charging USB-A ports coupled with an occupancy sensor controlling two 12V DC fans and an LED light circuit, ensuring comfort in even the smallest of enclosed spaces, while keeping power consumption at a minimum.
- Acoustic Ratings: NIC-36, STI .07
- Airflow Specifications: CFM 55

PRODUCT CODE	PRICE	SIZE/INCHES			WEIGHT LBS	VOL FT ³
		H	W	D		
POD1L	25852	88	44	38	800	85

POD2G • Two Person Meeting Pod - Glass/Laminate Back Panel

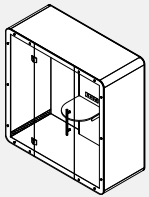

- Acoustic Meeting Pod includes laminate exterior with aluminum frame. PET interior provides acoustic privacy
- Includes D-Shaped Table 22.75" w x 22.75" d x 1" thick.
- Table can be installed at 26h, 28h or 30h
- Door is 10mm tempered glass
- Interior dimensions: 80" w x 36" d x 80" h
- Power + Connectivity: 2 AC outlets, USB-C and USB-A ports coupled with an occupancy sensor controlling two 12V DC fans and two LED lights, ensuring comfort in even the smallest of enclosed spaces, while keeping power consumption at a minimum.
- Acoustic Ratings: NIC-36, STI .07
- Airflow Specifications: CFM 55

PRODUCT CODE	PRICE	SIZE/INCHES			WEIGHT LBS	VOL FT ³
		H	W	D		
POD2G	46522	88	88	38	1200	170

POD3G • Office Pod - Glass Back Panel

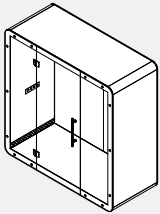

- Acoustic Office Pod includes laminate exterior with aluminum frame. PET interior provides acoustic privacy.
- Full tempered glass back
- Can accommodate a single task chair and small desk 36w x 24d (sold separately)
- Door is 10mm tempered glass
- Interior dimensions: 80" w x 36" d x 80" h
- Power + Connectivity: 2 AC outlets, USB-C and USB-A ports coupled with an occupancy sensor controlling two 12V DC fans and two LED lights, ensuring comfort in even the smallest of enclosed spaces, while keeping power consumption at a minimum.
- Acoustic Ratings: NIC-36, STI .07
- Airflow Specifications: CFM 55

PRODUCT CODE	PRICE	SIZE/INCHES			WEIGHT LBS	VOL FT ³
		H	W	D		
POD3G	43102	88	88	38	1200	170

Why Softpod?

Softpod is where flexibility meets focus - bringing a new work style option to the Global family of products. This sleek privacy pod is a cozy, secluded space dedicated to focus. Its multi-segmented dividers and hexagon shape offer flexibility for both privacy and space planning.

Divider:

- PET Felt / aluminum composition
- Channel edge allows for add-on privacy

PET Felt features:

- Tackable acoustic material
- Soft form capability

Electrical:

- Simple interconnect / direct plug-in or
- Hard wire formats

Storage:

- Solution based

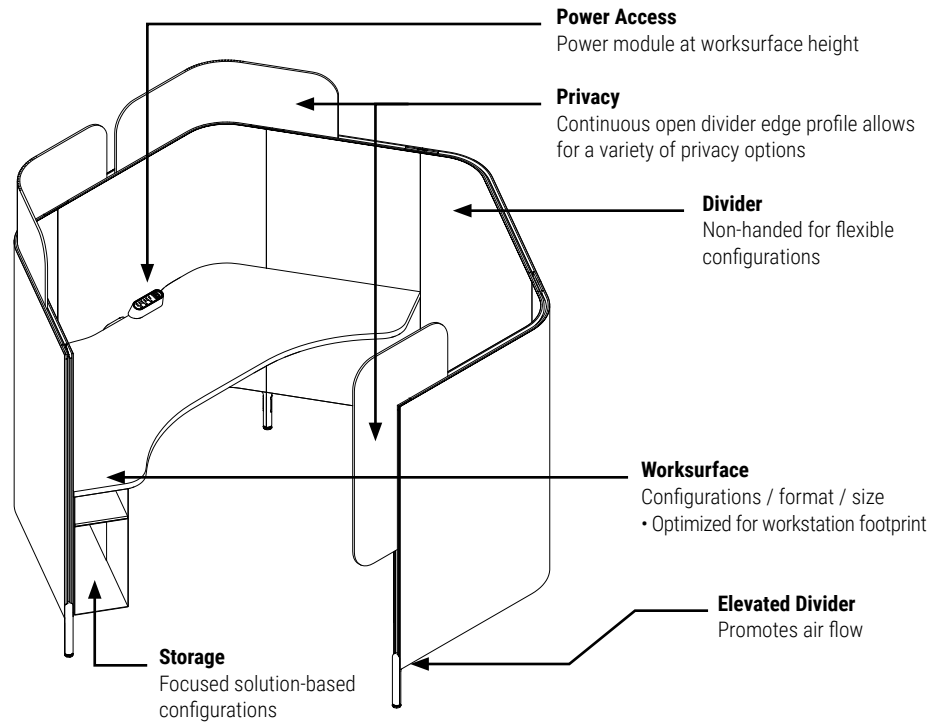

Statement Of Line

Softpods

HX3P5472SW
Softpod with 3 Dividers
and Worksurface

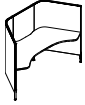

HX4P5472SW
Softpod with 4 Dividers
and Worksurface



HX4P5472R/LW
Softpod with 4 Dividers and
Wrap Around Worksurface



HX5P5472SW
Softpod with 5 Dividers
and Worksurface

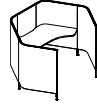

HX5P5472R/LW
Softpod with 5 Dividers and
Wrap Around Worksurface

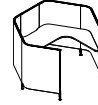

HXP5430
Single J-divider



Extensions

HXPAEFE
End PET Felt Extension
Divider Add-on



HXPACFE
Corner PET Felt Exten-
sion Divider Add-on



HXPATCFE
Top Corner PET Felt Ex-
tension Divider Add-on



Electrical

BRED50AC
Duo Module



HXEUWC
Under Worksur-
face/ Edge USB
Charger

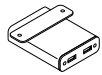

GAADG
Access Door
Module



GAADCT
Access Door Module
with Cable Tray

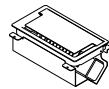

GMDSA10
ModPower Starter
Mounted Unit



GMDCA3
ModPower Middle
Mounted Unit



GMDEA3
ModPower End
Mounted Unit

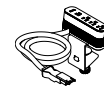

GMDSF10
ModPower In Surface
Starter Unit

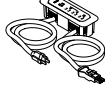

GMDCF3
ModPower In
Surface Middle Unit



GMDEF3
ModPower In
Surface End Unit

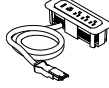

GMDCLIPS
ModPower Man-
agement Clips



GMDJ36BK
ModPower Intercon-
necting Jumper



GMDFC22W
Slim Desktop Power
Module, 2 Duplex



GMDFC32W
Slim Desktop Power
Module, 3 Duplex



HXEPK
Station 2-Circuit
Power Kit



HXECS
Cable Shroud



HXEPPJ
Station to Station
Jumper



HXECF
Ceiling Feed



HXEBF
Base Feed



HXECFP
Ceiling Feed Pole



HXEPGK
Divider Grommet
Kit



HXEPGCS
Divider Grommet
Connector / Spacer



Accessories

BLVELEDVS
LED Single Arm
Lamp



BLVELEDVD
LED Double Arm
Lamp



BLVELEDRS
LED Single Arm
Lamp



BLVELEDRD
LED Double Arm
Lamp



BLVELEDASCM
Lamp Mounting
Options



BLVELEDAFS
Lamp Mounting
Options



HXAHS
Hanging Shelf



HXAHSWB
Hanging Shelf with
Dry Erase Board



HXARWS
Rear Wall Shelf



HXACHS
Coat/Bag Hook
for Dividers



HXACTH
Coat/Bag Hook
for Dividers Edge



HXABH
Under Surface
Bag Hook



HXNP
Name Plate



Storage

HXSCSO
Under Work-
surface Casual
Storage Unit



L2PO
Pantry Storage

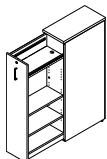

Footprint

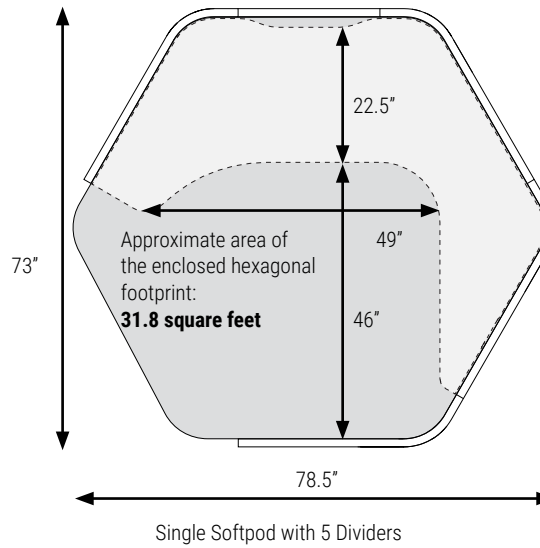
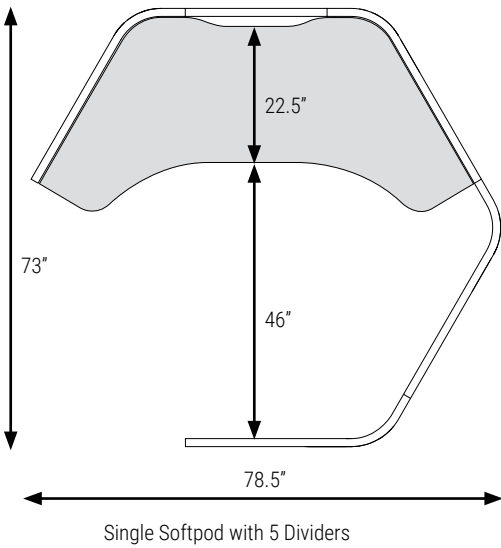
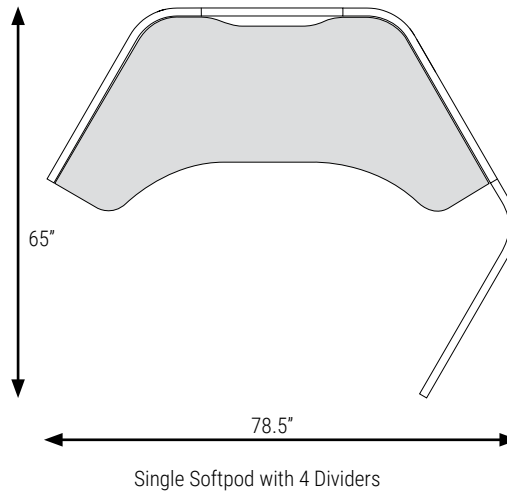
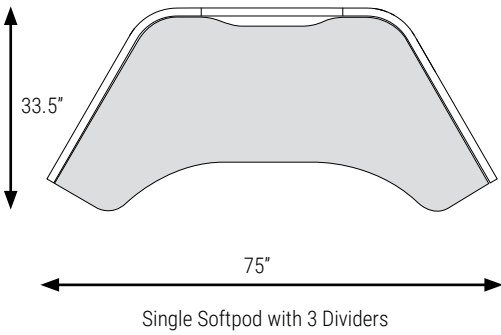

Off Grid Planning

The flexible format of Softpod offers a variety of planning options and encourages both on and off grid layouts. From a single or cluster of Softpods this versatile system adapts to your needs.

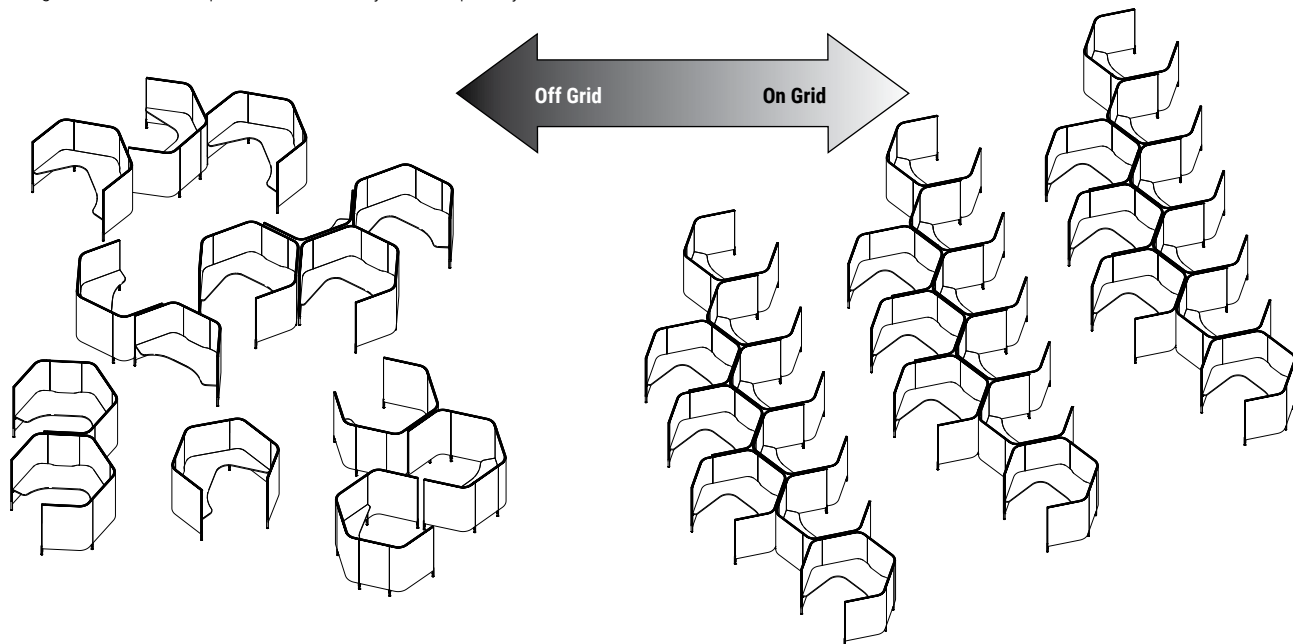

Off Grid Planning

Agile

The freestanding, single Softpod can flex to support any number of employees in a hybrid work environment. The pods can be easily reconfigured and adjusted as needs change. Its small kit of parts and thoughtfully designed features make it easy to specify and keep inventory counts low. Easy to specify and keep inventory counts low.

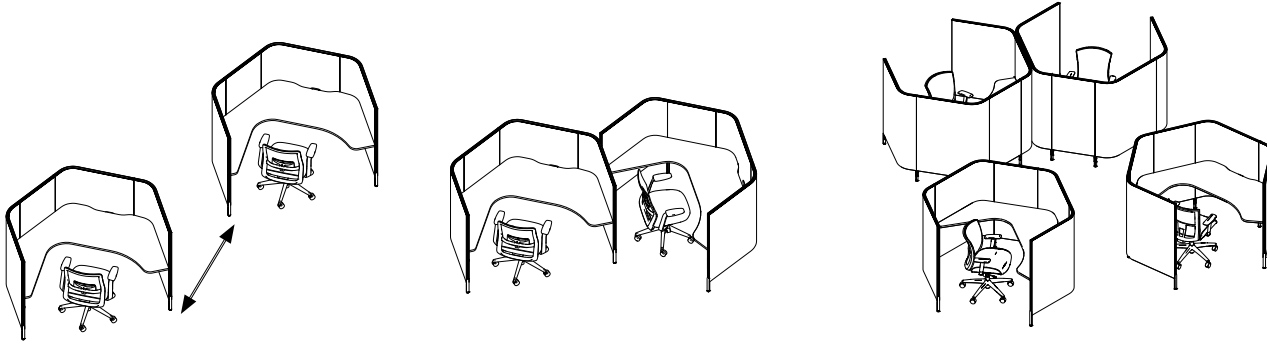

Scalable

The adaptable dividers give the ability to address the level of privacy needed on a station by station basis.

Softpod PRIVACY

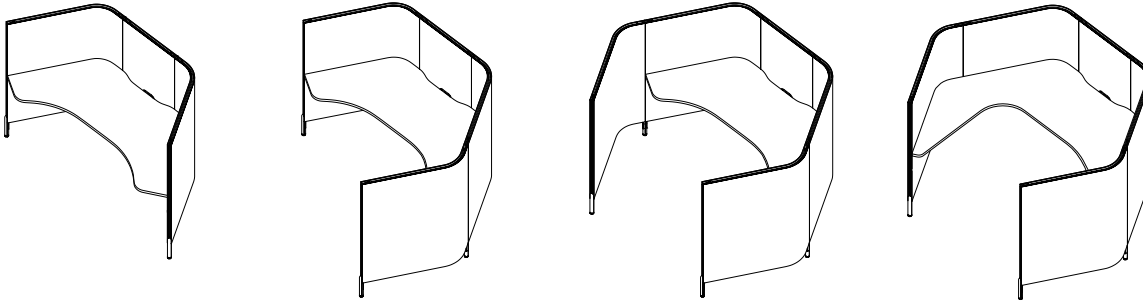

Extensions - PRIVACY

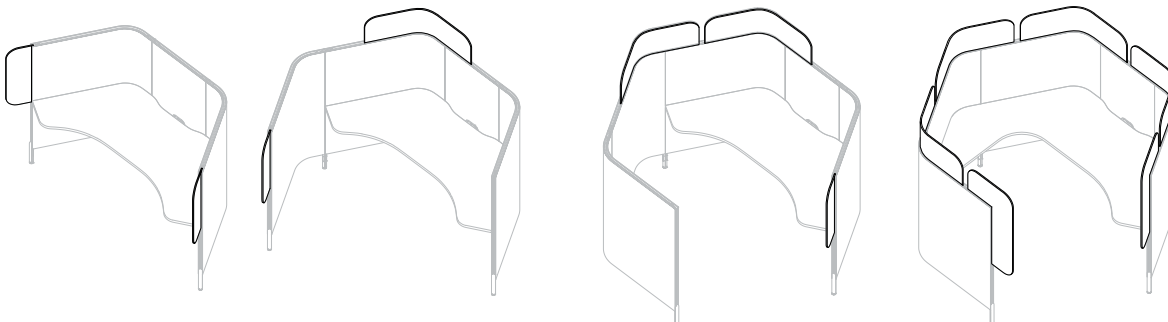

Quick Specification

Softpod's small and complete kits allows for quick and efficient movement of product from time of specification to installation.

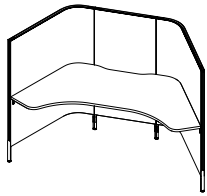

Single Pod with 3 Dividers

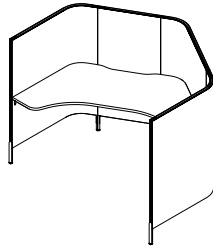

Single Pod with 4 Dividers

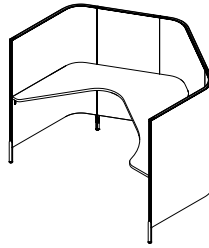

Single Pod with 4 Dividers and Wrap Around Surface

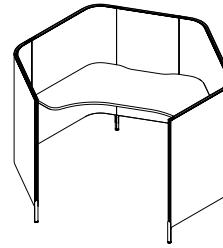

Single Pod with 5 Dividers

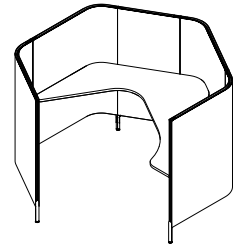

Single Pod with 5 Dividers and Wrap Around Surface

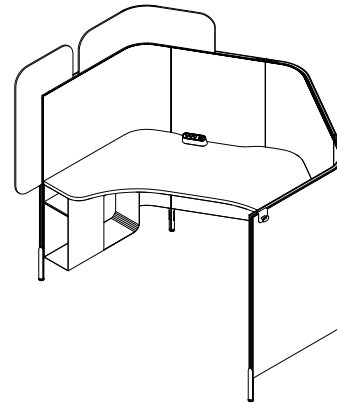
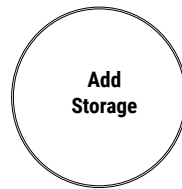
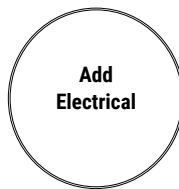

Power Connections

Plug In

Simple casual wire - Direct plug-in or hard wired.

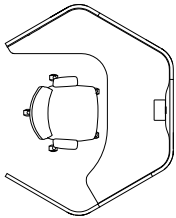

Daisy Chain Interconnect System

Plug-in power supply and interlinked, pre-determined, universal modules. If specified, one module is shipped with the station and interconnected on site.

Integrating additional station (C) requires disconnecting A from B and plugging in the C on site.

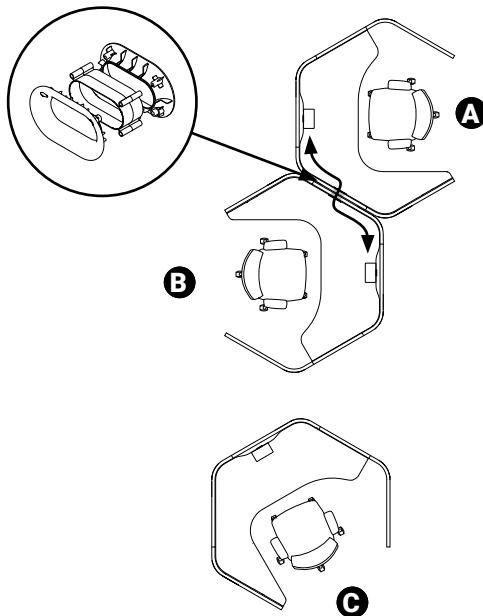

Dual Circuit Power

Outlets mounted below worksurfaces.

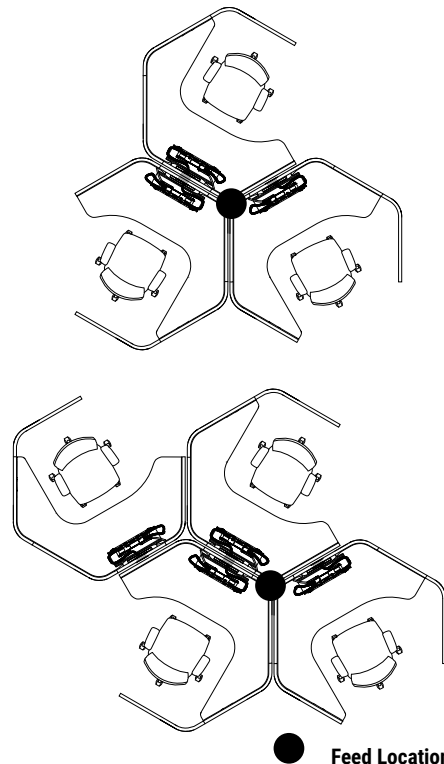

Space Planning

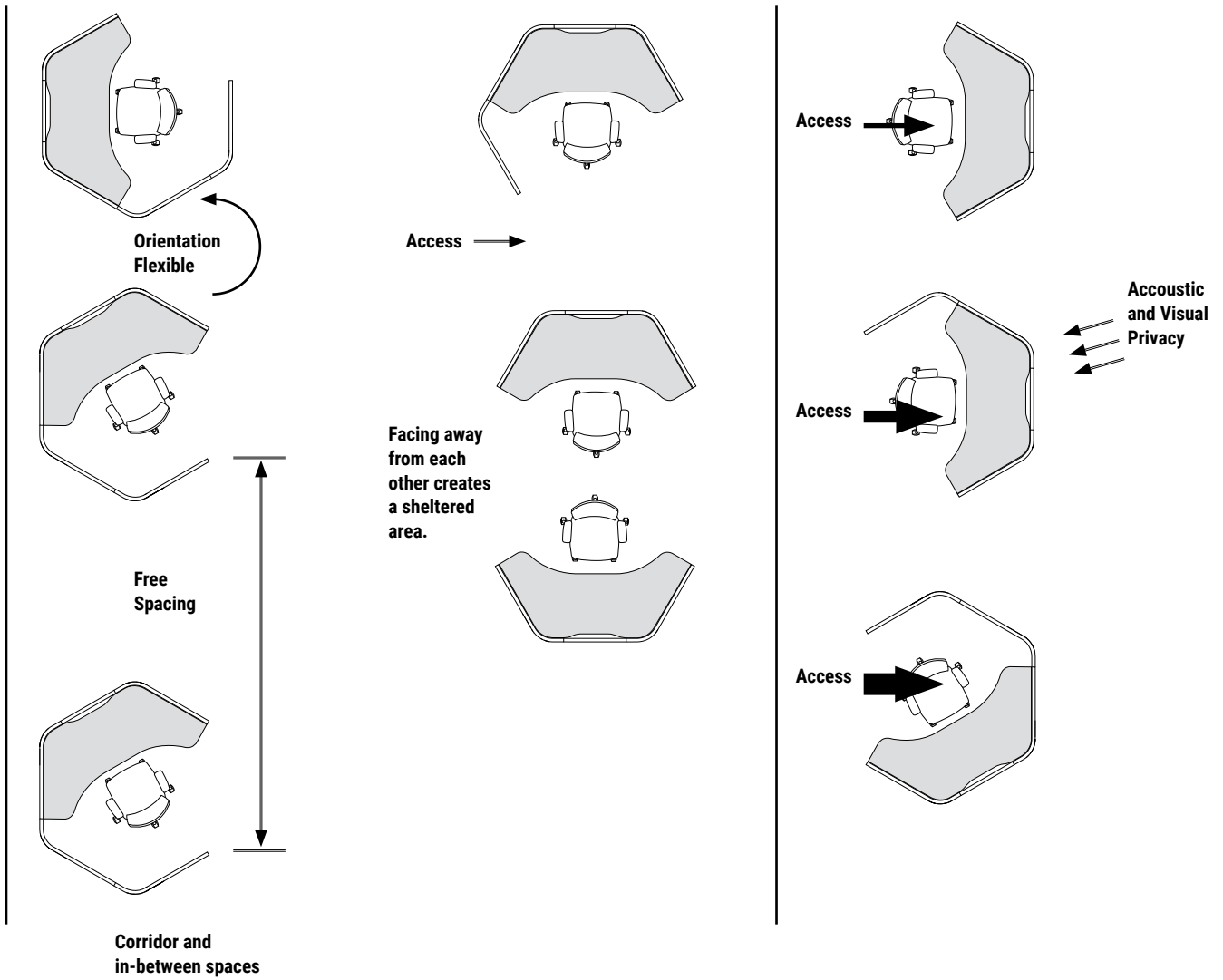

Pod Formats

Align units in cluster plan
Option unit type & orientation

(A) Worksurfaces must have opposing alignment

Flat and curved dividers are non-handed and symmetrical. The addition of the legs determines if the j-dividers becomes LEFT handed or RIGHT handed. Any j-divider can be configured and re-configured LEFT or RIGHT.

Maximum 4 unit cluster per 2 circuits

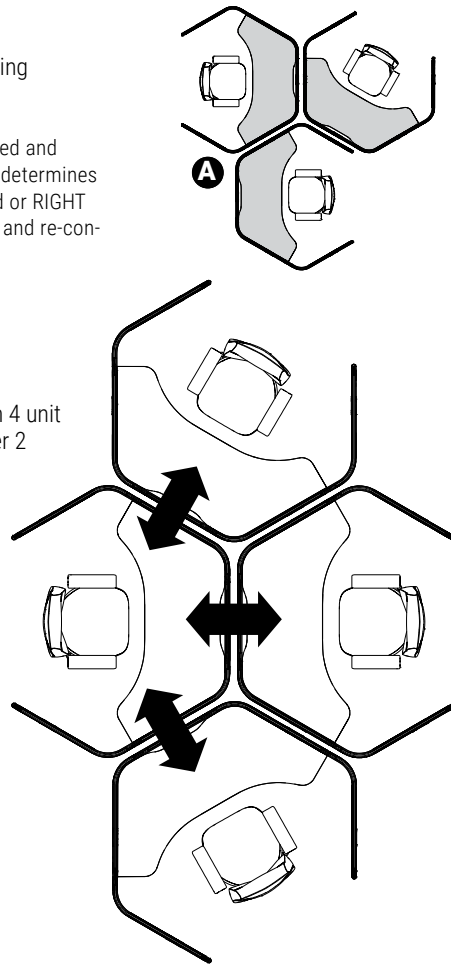

Power/ data is delivered through divider via grommet

Grommet tethers units together

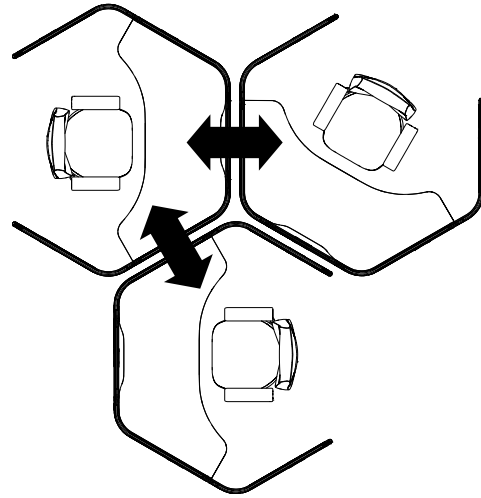

Planning for Single Softpod with 3 Dividers

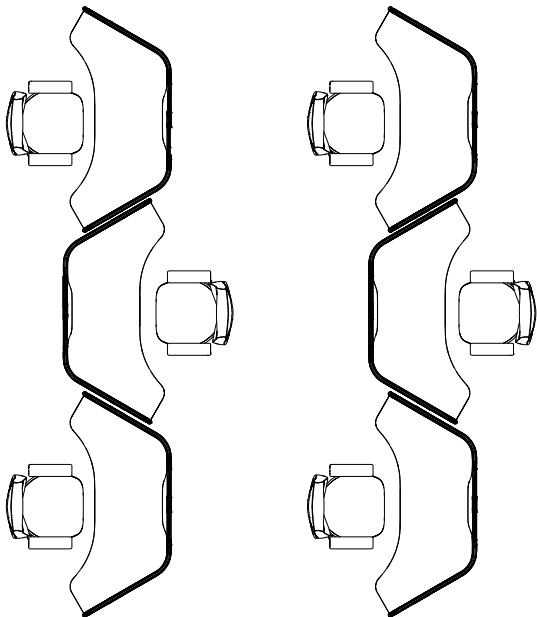

Touchdown

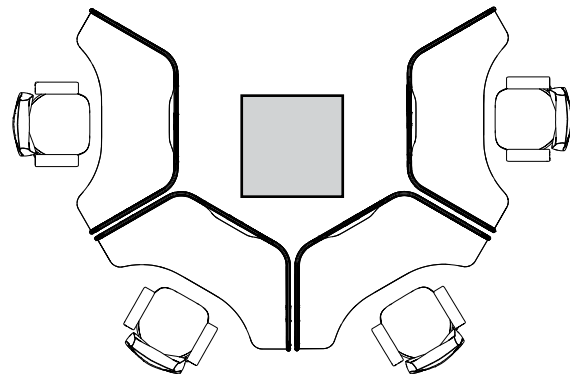

Around Column

Planning for Single Softpod with 4 Dividers

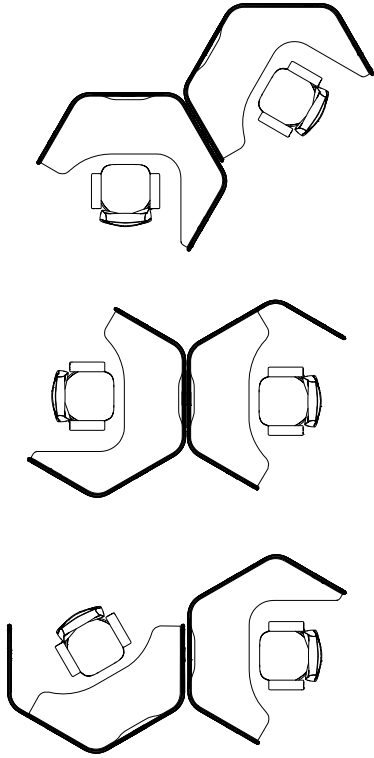

Cluster of 2 Softpods

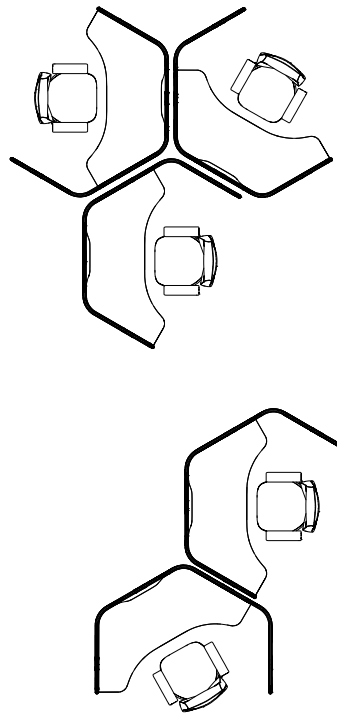

Cluster of 3 Softpods

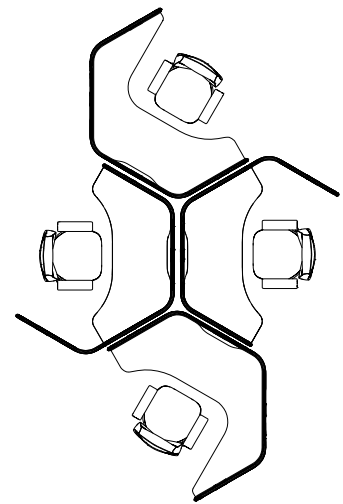

Cluster of 4 Softpods

Planning for Single Softpod with 5 Dividers - Center

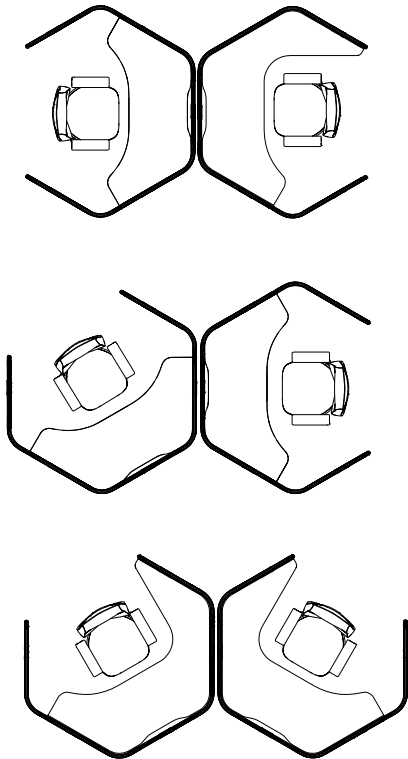

Cluster of 2 Softpods

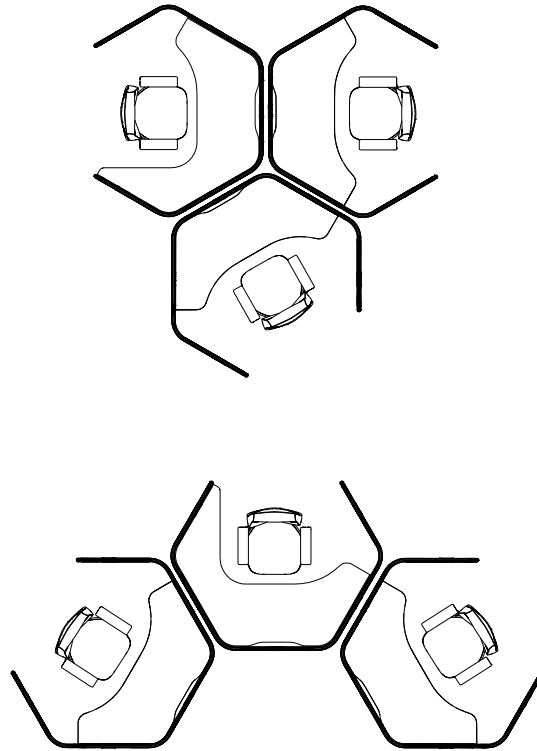

Cluster of 3 Softpods

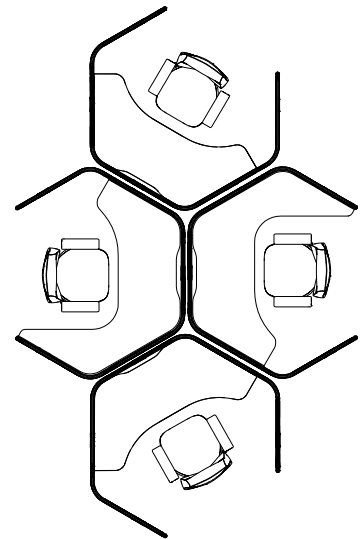

Cluster of 4 Softpods

Planning for Single Softpod with 5 Dividers Left/Right

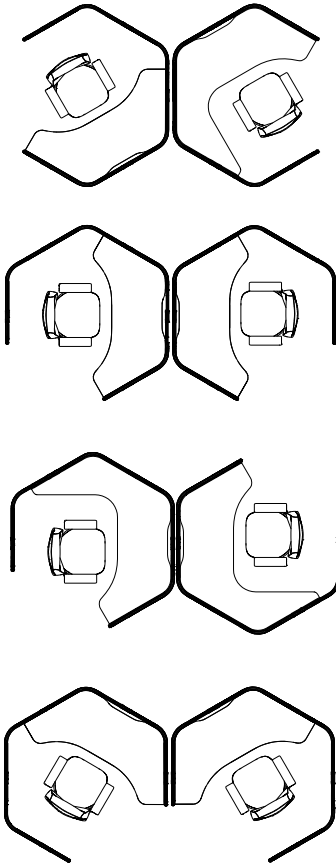

Cluster of 2 Softpods

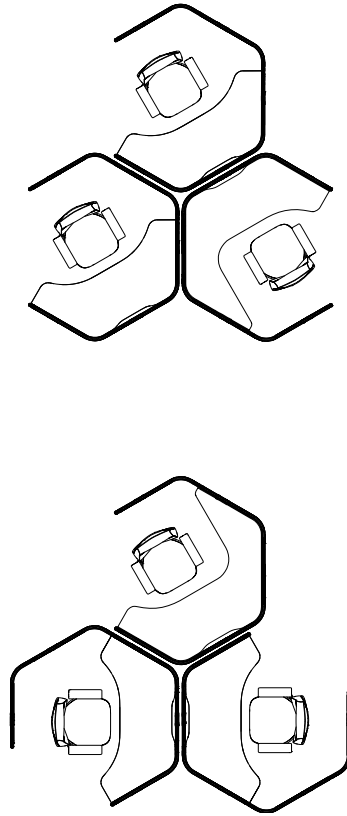

Cluster of 3 Softpods

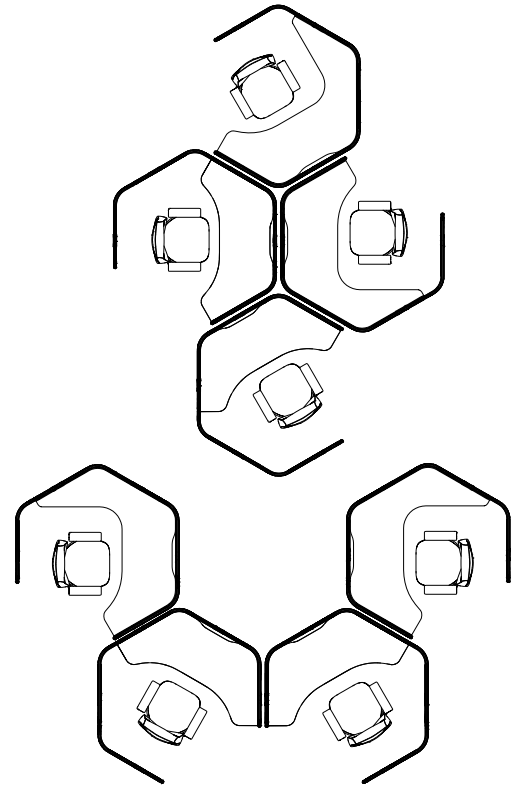

Cluster of 4 Softpods

Privacy Extensions

Flexible privacy extensions can be added to any Softpod workstation to adjust the level of privacy based on the user's needs.

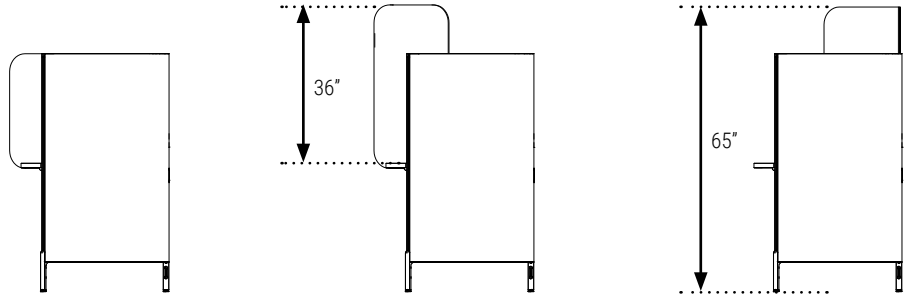
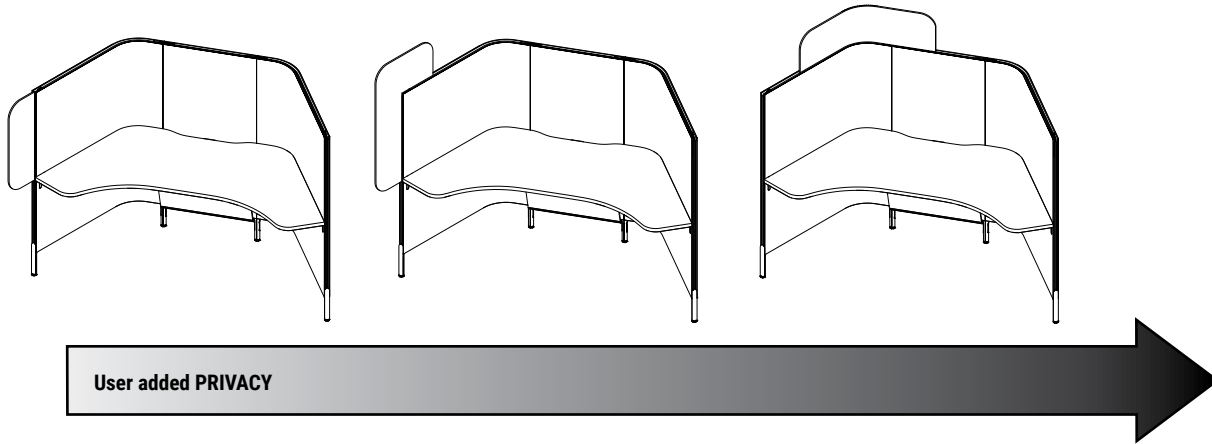

End PET Felt Extension Divider Add-on
 Height: 25.5"
 Depth: 9mm
 Width: 9.5"
 PET Felt
 - solid



Top Corner PET Felt Extension Divider Add-on
 Height: 37"
 Depth: 9mm
 Width: 19.5"
 PET Felt
 - solid
 - perforated



Corner PET Felt Extension Divider Add-on
 Height: 11.5"
 Depth: 9mm
 Width: 38.5"
 PET Felt
 - solid
 - perforated

Privacy Extensions

PET Felt - Solid

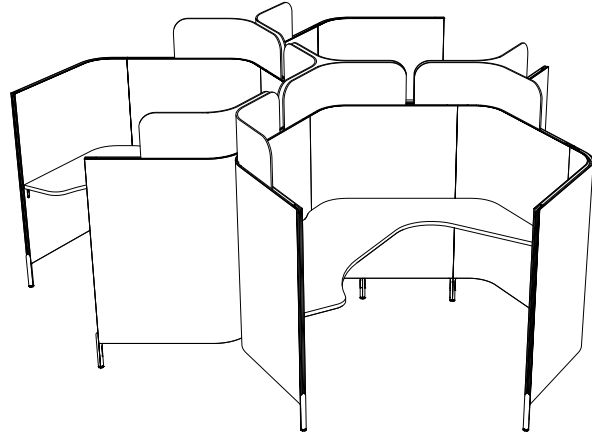
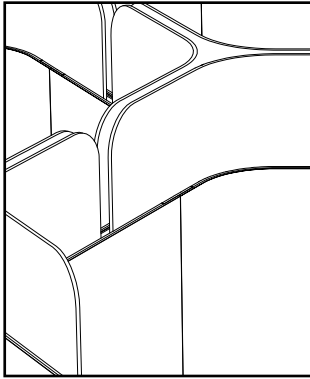

PET Felt - Perforated

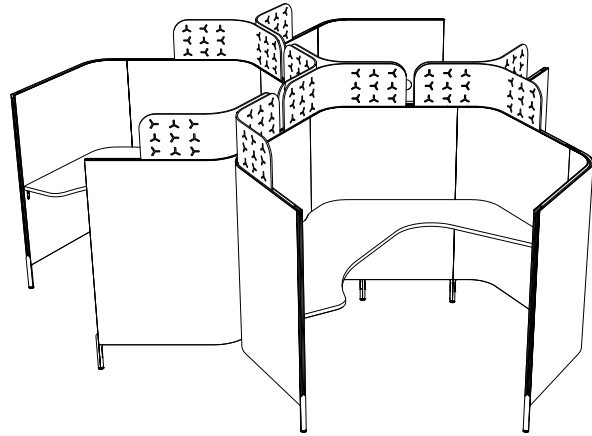
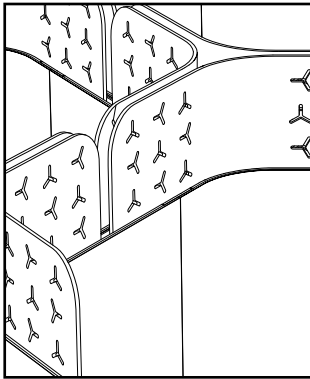

PET Felt Colour Programming

PET Felt finishes may be the same or different for the interior and exterior of the Softpod. Only one finish may be applied to either the interior or exterior of each divider within each Softpod. Extensions may be in any single PET Felt colour to compliment or contrast. Due to variation in the color of felt, we recommend a contrasting or complimentary colour.

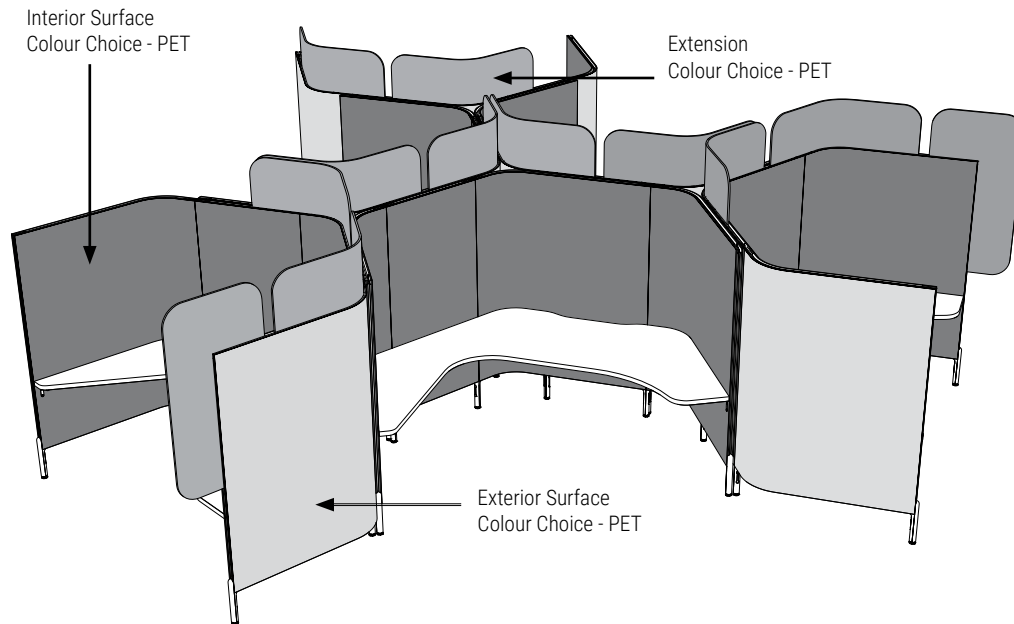

Worksurface Dimensions and Grain Direction

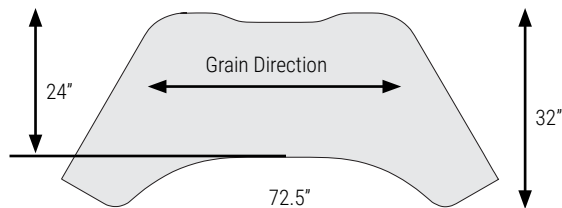

Standard Worksurface

- A single worksurface to be used within Softpod dividers.
- The surface is non handed with pre-determined mounting points.
- Choose from either standard LP - low pressure laminate or HP - high pressure laminate, with PVC edge.

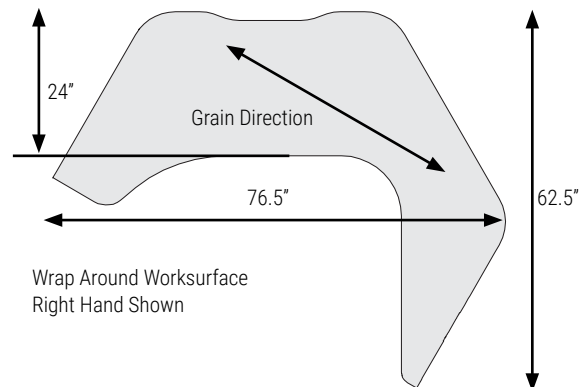

Wrap Around Worksurface
Right Hand Shown

- A single wrap around worksurface to be used within Softpod dividers.
- The surface is handed L -left or R -right with pre-determined mounting points.
- Compatible only with 4 or 5 divider station configurations.
- Choose from either standard LP - low pressure laminate or HP - high pressure laminate, with PVC edge.

Grommet Location

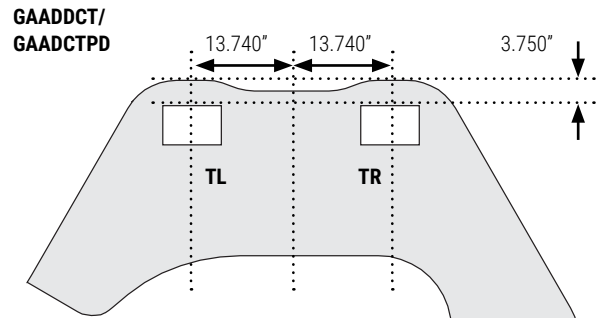
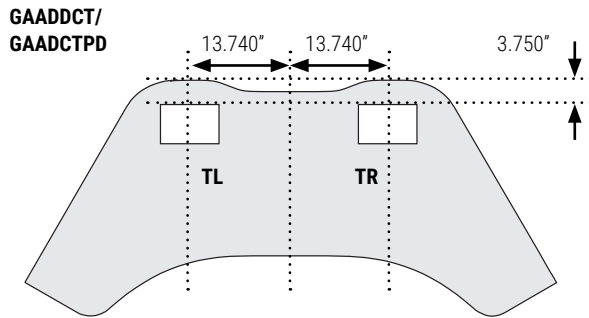

Right Hand Shown

- Grommet cutout option for GAADS series and Mod Power. TR -top right or TL -top left. Grommets must be ordered separately.
- GAAD grommet is not available in combination with HXECS (Cable Shroud) and HXEPK (2 Circuit Power Kit).

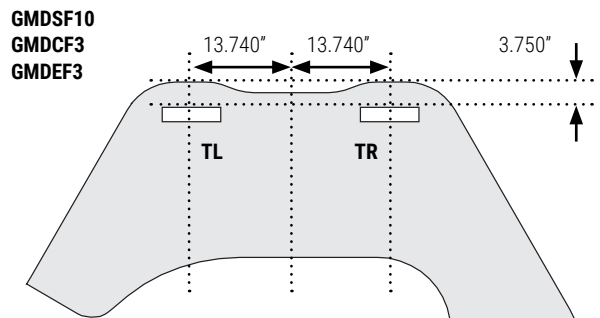
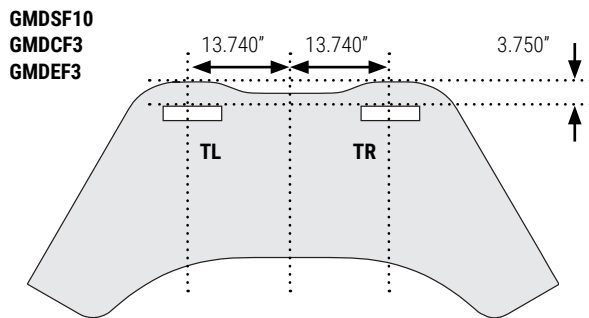
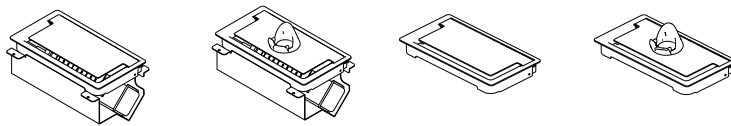

Right Hand Shown

- Grommet cutout option for GAADS series and Mod Power. TR -top right or TL -top left. Grommets must be ordered separately.
- GAAD grommet is not available in combination with HXECS (Cable Shroud) and HXEPK (2 Circuit Power Kit).

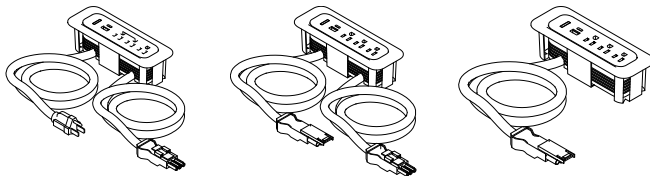

Electrical

Power and data lines can enter Softpod via floor, ceiling, or through grommet in the divider. The grommet opening is built-into every Softpod divider at a specific location, but it is covered by an on-site removable PET plug.

A grommet on a single Softpod can also facilitate cable access to a wall outlet.

Grommets installed on specific dividers facilitate passage of wires through Softpod dividers into adjacent Softpods.

Orientation of worksurfaces plays important role when planning Softpod cluster layouts with the need to pass cables between individual Softpods as the cables are best hidden underneath.

Worksurfaces must have opposing alignment.

Align units in cluster plan option unit type & orientation.

(A) Worksurfaces must have opposing alignment.

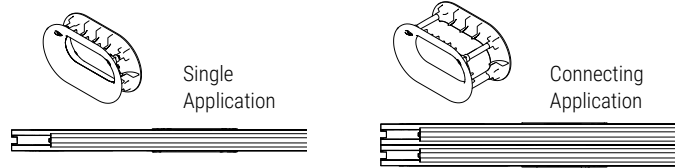
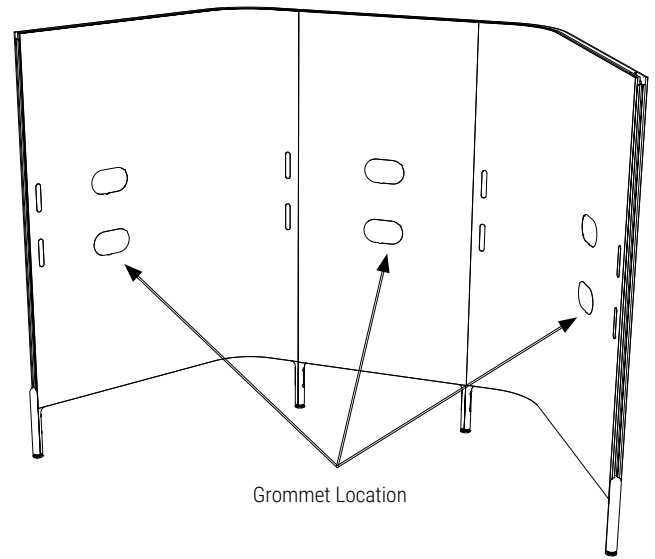
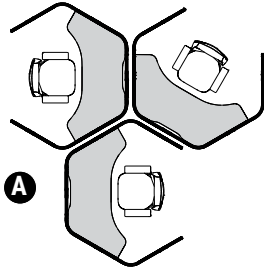

Ceiling pole attaches to the divider grommet under worksurface.

Location of the Ceiling pole on the inside of the Softpod is determined by the contoured recess at the back of worksurface.

White dots below indicate possible ceiling feed pole location within the Pod (must be at the same location as worksurface contoured recess).

Grey dots indicate possible Ceiling fee pole location outside of the POD (because cables pass through the divider grommets and under the worksurface).

Black arrows indicate possible power and data cable passage between Softpods (because cables pass through the divider grommet under the worksurface, through the second divider grommet and into the adjacent Softpod, under worksurface).

In either case, the cables enter or exit the Softpod through the divider grommet.

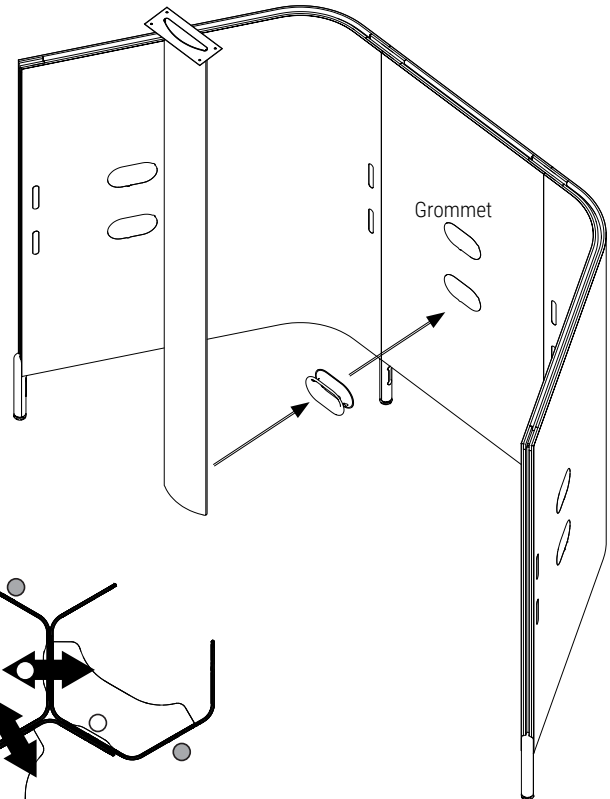

Recommended Maximum 4 unit cluster per 2 circuits.

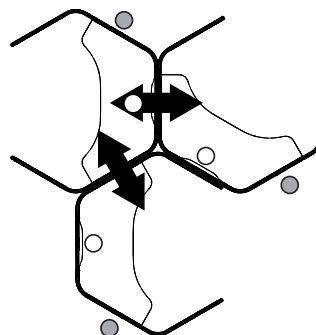
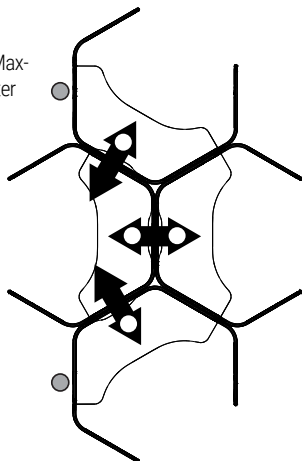

● Ceiling Feed Pole Location

Electrical Options

Direct Plug In

- Direct or floor monument outlet plug-in.

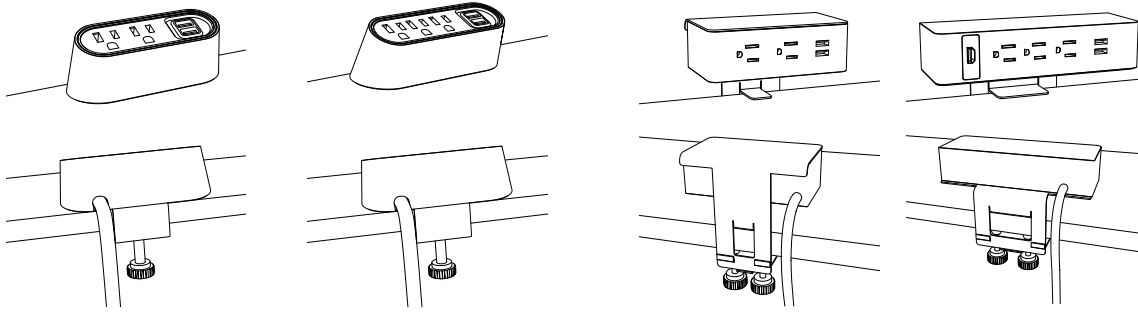

Grommet Application

- In surface.

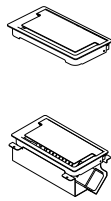
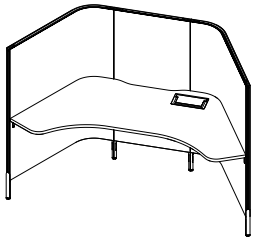

Grommet Application

- In surface Daisy Chain.

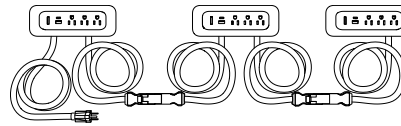
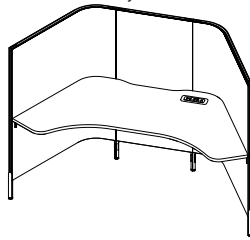

Daisy Chain Interconnect System

- Direct or floor monument outlet plug-in.

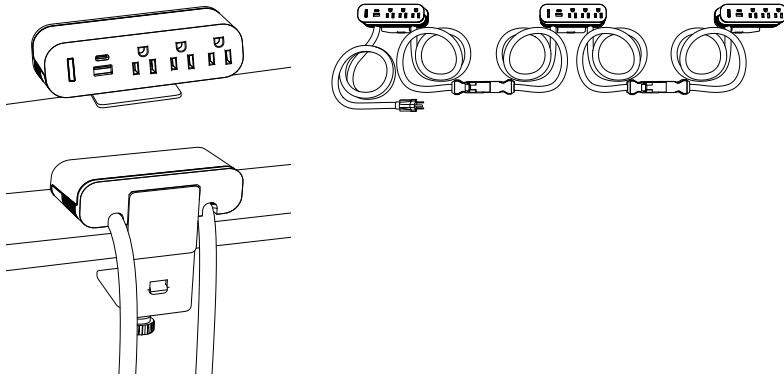

Dual Circuit Power

- Hardwired

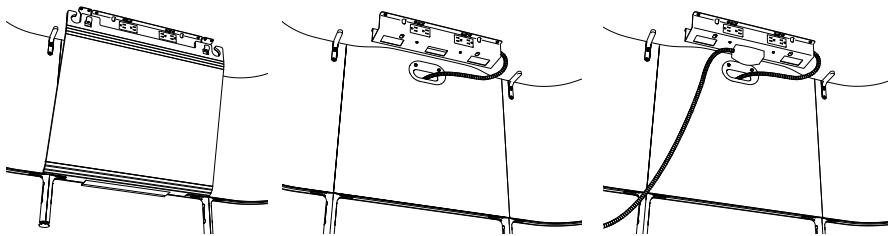

Floor Feed

Ceiling Feed

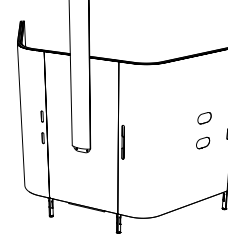

Electrical

2 Circuit, 4 Wire Power Distribution

The 2-circuit, 4-wire electrical components are housed in a metal trough, mounted under worksurface, immediately adjacent to the worksurface contoured recess.

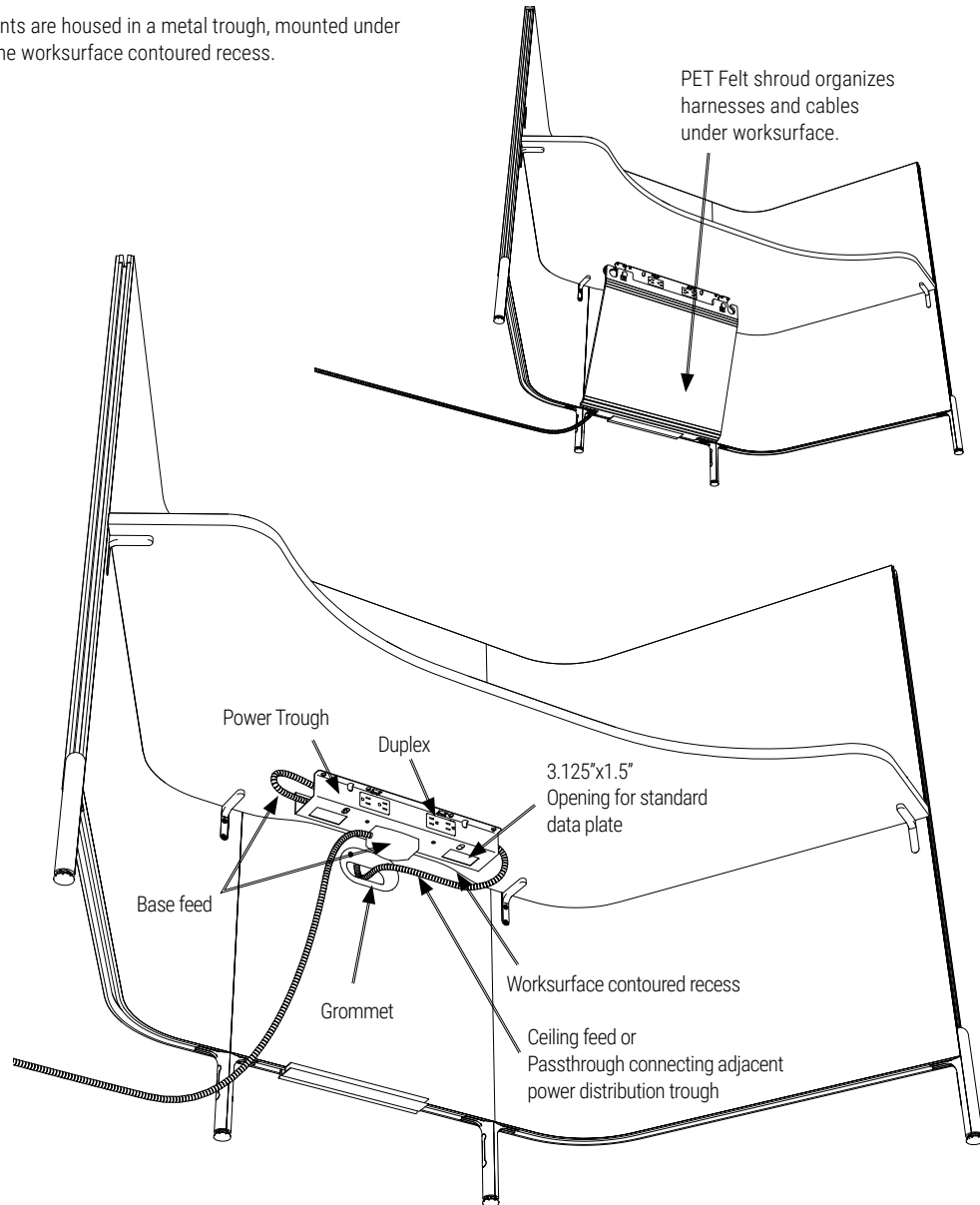

Storage

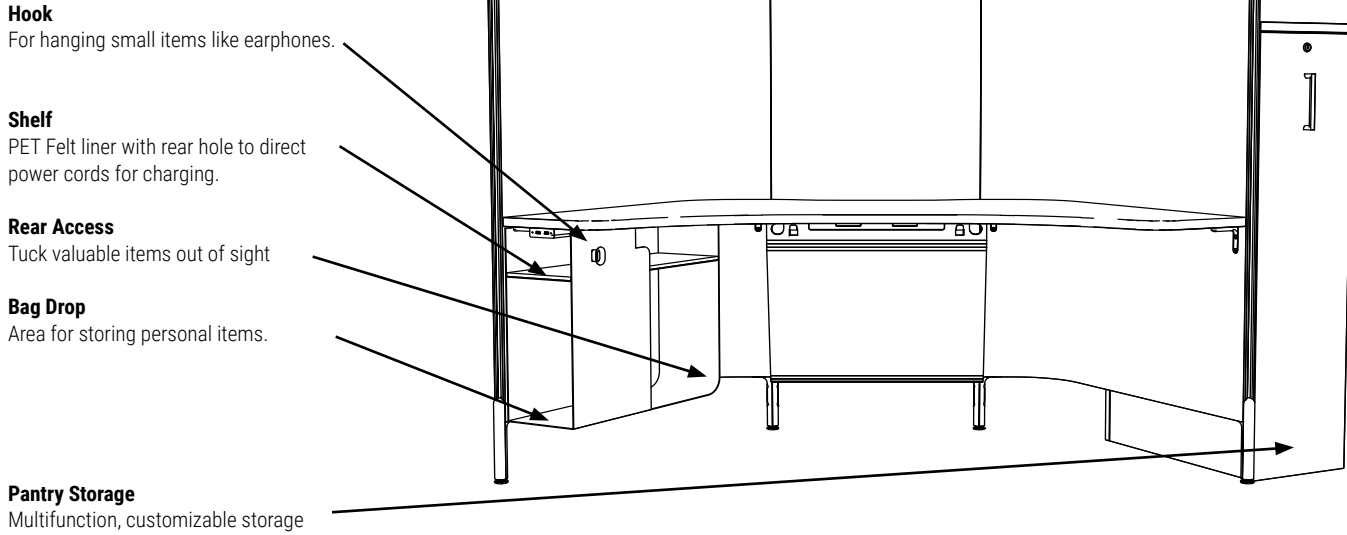

Accessories

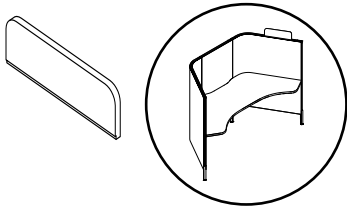

**HXNP
Name Plate**
Height: 3.5"
Depth: 0.5"
Width: 11"
• Two sided white dry erase surface.

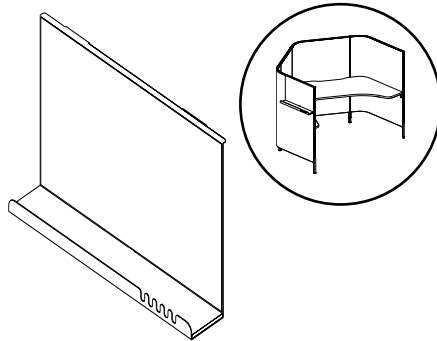

**HXAHS
Hanging Shelf**
Height: 16"
Depth: 3"
Width: 23.5"
• Optional dry erase board available

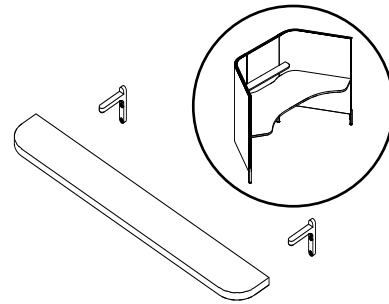

**HXARWS
Rear Wall Shelf**
Height: 3/4"
Depth: 4.5"
Width: 32.5"
• Laminate
NOTE : Not compatible with Ceiling Feed Pole or any monitor mounts.

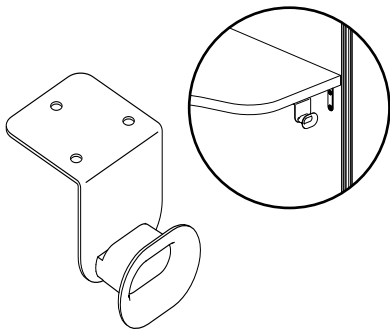

**HXABH
Under Surface Bag Hook**

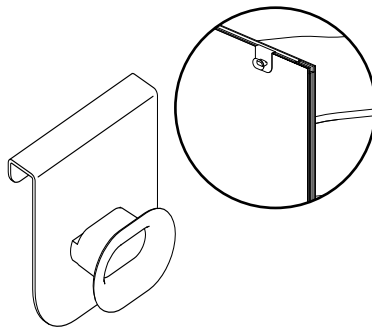

**HXACHT
Coat, Bag Hook for horizontal
divider edge**

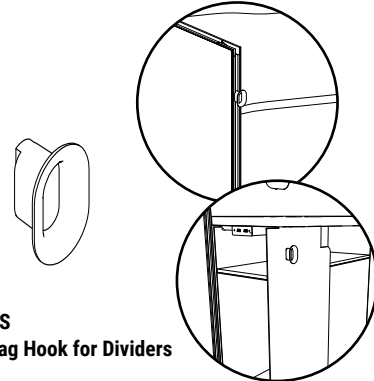

**HXACHS
Coat, Bag Hook for Dividers**

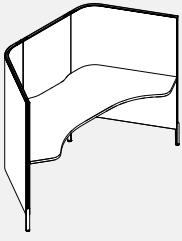
HX3P5472SW • Softpod with 3 Dividers and Worksurface

- Complete 3 divider pod consisting of one straight back divider, two side j-dividers and one standard worksurface.
- Installed pod measures 54"h from the floor, 25" from top of surface and has a clearance of 6 3/8" at floor level.
- Dividers are surfaced with tackable PET Felt. Please choose any standard PET Felt color. Interior PET Felt color may be different than the outer.
- The divider perimeter reveal trim accepts privacy extensions and is made of polypropylene available only in CHR - Charcoal.
- Surface choice of LP - low pressure or HP - high pressure laminate with PVC edge. Please choose any standard laminate and PVC edge.
- Metal legs are powder coated paint. Please choose CHR - Charcoal or DWT - Designer White.
- Complete pod includes all connecting hardware, tubular legs and supporting brackets.
- Extensions, electrical, storage and accessories are specified separately.

PRODUCT CODE	PRICE		SIZE/INCHES			WEIGHT LBS	VOL FT ³
	LP	HP	H	W	D		
HX3P5472SW	2910	3293	54	72	30	141	22.92

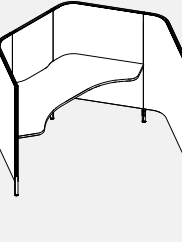
HX4P5472SW • Softpod with 4 Dividers and Worksurface

- Complete 4 divider pod consisting of one straight back divider, three side j-dividers and one standard worksurface.
- Installed pod measures 54"h from the floor, 25" from top of surface and has a clearance of 6 3/8" at floor level.
- Dividers are surfaced with tackable PET Felt. Please choose any standard PET Felt color. Interior PET Felt color may be different than the outer.
- The divider perimeter reveal trim accepts privacy extensions and is made of polypropylene available only in CHR - Charcoal.
- Surface choice of LP - low pressure or HP - high pressure laminate with PVC edge. Please choose any standard laminate and PVC edge.
- Metal legs are powder coated paint. Please choose CHR - Charcoal or DWT - Designer White.
- Complete pod includes all connecting hardware, tubular legs and supporting brackets.
- Wing divider can be installed left or right.
- Extensions, electrical, storage and accessories are specified separately.

PRODUCT CODE	PRICE		SIZE/INCHES			WEIGHT LBS	VOL FT ³
	LP	HP	H	W	D		
HX4P5472SW	3654	4036	54	72	65	170	25.41

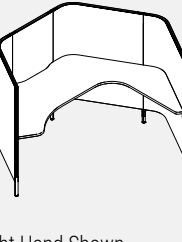
HX4P5472R/LW • Softpod with 4 Dividers and Wrap Around Worksurface

Right Hand Shown

- Complete 4 divider pod consisting of one straight back divider, three side j-dividers and one standard wrap around work surface.
- Installed pod measures 54"h from the floor, 25" from top of surface and has a clearance of 6 3/8" at floor level.
- Dividers are surfaced with tackable PET Felt. Please choose any standard PET Felt color. Interior PET Felt color may be different than the outer.
- The divider perimeter reveal trim accepts privacy extensions and is made of polypropylene available only in CHR - Charcoal.
- Surface choice of LP - low pressure or HP - high pressure laminate with PVC edge. Please choose any standard laminate and PVC edge.
- Metal legs are powder coated paint. Please choose CHR - Charcoal or DWT - Designer White.
- Complete pod includes all connecting hardware, tubular legs and supporting brackets.
- Extensions, electrical, storage and accessories are specified separately.

PRODUCT CODE	PRICE		SIZE/INCHES			WEIGHT LBS	VOL FT ³
	LP	HP	H	W	D		
HX4P5472RW	3977	4516	54	72	65	185	25.41
HX4P5472LW	3977	4516	54	72	65	185	25.41

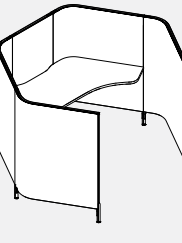
HX5P5472SW • Softpod with 5 Dividers and Worksurface

- Complete 5 divider pod consisting of one straight back divider, four side j-dividers and one standard worksurface.
- Installed pod measures 54"h from the floor, 25" from top of surface and has a clearance of 6 3/8" at floor level.
- Dividers are surfaced with tackable PET Felt. Please choose any standard PET Felt color. Interior PET Felt color may be different than the outer.
- The divider perimeter reveal trim accepts privacy extensions and is made of polypropylene available only in CHR - Charcoal.
- Surface choice of LP - low pressure or HP - high pressure laminate with PVC edge. Please choose any standard laminate and PVC edge.
- Metal legs are powder coated paint. Please choose CHR - Charcoal or DWT - Designer White.
- Complete pod includes all connecting hardware, tubular legs and supporting brackets.
- Wing dividers can be installed both on left or right side or one on each side.
- Extensions, electrical, storage and accessories are specified separately.

PRODUCT CODE	PRICE		SIZE/INCHES			WEIGHT LBS	VOL FT ³
	LP	HP	H	W	D		
HX5P5472SW	4462	4845	54	72	65	198	25.41

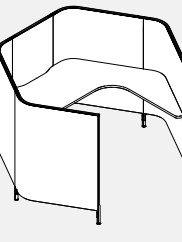
HX5P5472R/LW • Softpod with 5 Dividers and Wrap Around Worksurface

Right Hand Shown

- Complete 5 divider pod consisting of one straight back divider, four side j-dividers and one standard wrap around work surface.
- Installed pod measures 54"h from the floor, 25" from top of surface and has a clearance of 6 3/8" at floor level.
- Dividers are surfaced with tackable PET Felt. Please choose any standard PET Felt color. Interior PET Felt color may be different than the outer.
- The divider perimeter reveal trim accepts privacy extensions and is made of polypropylene available only in CHR - Charcoal.
- Surface choice of LP - low pressure or HP - high pressure laminate with PVC edge. Please choose any standard laminate and PVC edge.
- Metal legs are powder coated paint. Please choose CHR - Charcoal or DWT - Designer White.
- Complete pod includes all connecting hardware, tubular legs and supporting brackets.
- Extra wing divider can be installed on left or right side.
- Extensions, electrical, storage and accessories are specified separately.

PRODUCT CODE	PRICE		SIZE/INCHES			WEIGHT LBS	VOL FT ³
	LP	HP	H	W	D		
HX5P5472RW	4739	5277	54	72	65	213.36	25.41
HX5P5472LW	4739	5277	54	72	65	213.36	25.41

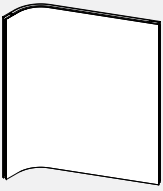
HXP5430 • Single J-divider

- A single divider is curved; non-handed symmetrical along the horizontal axis.
- J-dividers are surfaced with tackable PET Felt. Please choose any standard PET Felt color. Interior PET Felt color may be different than the outer.
- Installed pod measures 54"h from the floor, 25" from top of surface and has a clearance of 6 3/8" at floor level.
- The divider perimeter reveal trim accepts privacy extensions and is made of polypropylene available only in CHR - Charcoal.
- J-divider comes complete with top connector kit, shared leg kit and trim.
- If a Single J-divider is ordered as an add-on to a previous order, the PET Felt finish may or may not match based on dyelot and fading.
- Single J-divider is not intended to be used alone without a complete kit including a work surface due to stability and connectivity constraints.

PRODUCT CODE	PRICE	SIZE/INCHES			WEIGHT LBS	VOL FT ³
		H	W	D		
HXP5430AP	833	54	30	6	28.3	16.17

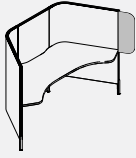
HXPAEFE • End PET Felt Extension Divider Add-on

- Designed to add 8.7" of additional privacy at the end of the divider.
- Fits into the base divider perimeter reveal and placement is user oriented.
- PET Felt divider surface is tackable. Choose from standard PET finishes.
- NOTE : Not available with a perforated pattern.

PRODUCT CODE	PRICE	SIZE/INCHES			WEIGHT LBS	VOL FT ³
		H	W	D		
HXPAEFE	40	25.4	9.3	0.35	0.63	0.05

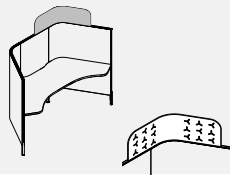
HXPACFE • Corner PET Felt Extension Divider Add-on

- Designed to add 11.1" of additional privacy at the top corner of the divider.
- Fits into the base divider perimeter reveal and placement is user oriented.
- Installed station with Corner PET Felt Extension Divider Add-on installed measures 65" from floor, 36" from top of worksurface.
- PET Felt divider surface is tackable. Choose from standard PET finishes.
- Perforated pattern option available, shown with "P" at the end of the code.

PRODUCT CODE	PRICE	SIZE/INCHES			WEIGHT LBS	VOL FT ³
		H	W	D		
HXPACFE	71	11.687	38.3	0.35	1.16	0.09
HXPACFEP	142	11.687	38.3	0.35	1.16	0.09

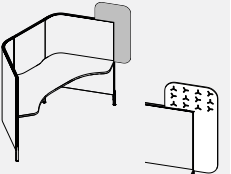
HXPATCFE • Top Corner PET Felt Extension Divider Add-on

- Designed to add 8.7" of additional privacy to the top of the divider and 11.1" at the end of the divider.
- Fits into the base divider perimeter reveal and placement is user oriented.
- Installed station with Corner PET Felt Extension Divider Add-on installed measures 65" from floor, 36" from top of worksurface.
- PET Felt divider surface is tackable. Choose from standard PET finishes.
- Perforated pattern option available, shown with "P" at the end of the code.

PRODUCT CODE	PRICE	SIZE/INCHES			WEIGHT LBS	VOL FT ³
		H	W	D		
HXPATCFE	77	37.1"	19.5	0.35	1.25	0.15
HXPATCFEP	154	37.1"	19.5	0.35	1.25	0.15

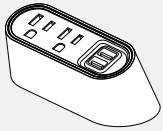
GMDPC22W • Slim Desktop Power Module, 2 Simplex

- Desktop power center with two 15A tamper resistant power receptacles, one USB-A and one USB-C (provides 3.1A); 10' power cord.
- Includes three mounting options (i) a screw-in mounting plate for forward facing outlets; or (ii) an under surface mount bracket; or (iii) a clamp mounting kit for 0.5-1.5" thick surfaces.
- Gloss white body with grey face.

PRODUCT CODE	PRICE	SIZE/INCHES			WEIGHT LBS	VOL FT ³
		H	W	D		
GMDPC22W	494	2.25	4.88	2.25	2.5	0.5

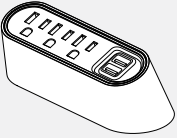
GMDPC32W • Slim Desktop Power Module, 3 Simplex

- Desktop power center with three 15A tamper resistant power receptacles, one USB-A and one USB-C (provides 3.1A); 10' power cord.
- Includes three mounting options (i) a screw-in mounting plate for forward facing outlets; or (ii) an under surface mount bracket; or (iii) a clamp mounting kit for 0.5-1.5" thick surfaces.
- Gloss white body with grey face.

PRODUCT CODE	PRICE	SIZE/INCHES			WEIGHT LBS	VOL FT ³
		H	W	D		
GMDPC32W	645	2.25	6.00	2.25	2.6	0.5

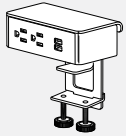
BRED50ACAC • Duo Module with A+C

- **The Duo power module is completely integrated with a mounting clamp to attach to the edge of a worksurface.**
- Provides two 15 Amp 120 Volt AC Receptacles; 2.4 amp USB-A port and 60 watt USB-C power delivery port.
- 10' long three-prong cord.
- Available in W - White or B - Black as indicated by last letter of model number.

PRODUCT CODE	PRICE	SIZE/INCHES			WEIGHT LBS	VOL FT ³
		H	W	D		
BRED50ACACW	695	3	5.5	3.2	3	0.2
BRED50ACACB	695	3	5.5	3.2	3	0.2

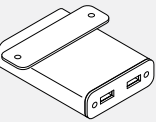
HXEUWC • Under Worksurface/ Edge USB Charger

- Under surface table mounted module - dual USB (A&C) charging ports.
- Consists of one 15 watt USB C charging outlet and one 2.1 amp USB A charging outlet.
- Unit has white housing, white powder coated mounting bracket and white electrical cord.

PRODUCT CODE	PRICE	SIZE/INCHES			WEIGHT LBS	VOL FT ³
		H	W	D		
HXEUWC	367	1	3	4	0.31	0.01

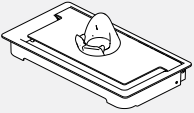
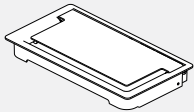
GAADG • Access Door Module

- Soft close door is set back from edge to allow for cable pass thru.
- Available in all standard divider frame finishes.
- GAADGDH includes device holder for most mobilephones or tablets. Holder is only available in white.
- FreeFit can only accommodate one grommet per worksurface.

PRODUCT CODE	PRICE	SIZE/INCHES			WEIGHT LBS	VOL FT ³
		H	D	W		
GAADG	60	1.08	5.54	10.09	2	0.04
GAADGDH	65	1.08	5.54	10.09	2	0.04

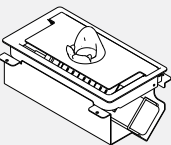
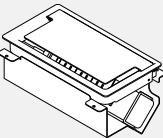
GAADCT • Access Door Module with Cable Tray

- Soft close door is set back from edge to allow for cable pass thru when closed.
- Cable tray comes one standard telcom knock out and a platform to mount a powerbar.
- Sides are open for easy access.
- Available in all standard divider frame finishes.
- GAADCTDH includes device holder for most mobile phones or tablets. Holder is only available in white.
- FreeFit can only accommodate one grommet per worksurface

PRODUCT CODE	PRICE	SIZE/INCHES			WEIGHT LBS	VOL FT ³
		H	D	W		
GAADCT	95	5.07	5.54	10.09	4	0.19
GAADCTDH	103	5.07	5.54	10.09	4	0.19

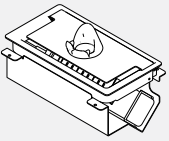
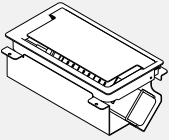
GAADCTPD • Access Door Module with Cable Tray and Power Bar

- Access door module with cable tray and power bar.
- Powerbar with 3 simplex and 2 USB, CSA Certified.
- Soft close door is set back from edge to allow for cable pass thru when closed.
- Cable tray comes one standard telcom knock out and a platform to mount a powerbar.
- Sides are open for easy access.
- Housing Paint Finish - TBD
- GAADCTPDDH includes device holder for most mobile phones or tablets.
- Holder is only available in white.
- One grommet per worksurface.

PRODUCT CODE	PRICE	SIZE/INCHES			WEIGHT LBS	VOL FT ³
		H	D	W		
GAADCTPD	208	6.96	5.54	10.09	4	0.20
GAADCTPDDH	212	6.96	5.54	10.09	4	0.20

ModPower Daisy Chain Solution

- Adds flexible power and USB charging to work surfaces.
- Connects up to four units with a single corded infeed with NEMA plug.
- ModPower units are sold separately.
- Begin the run with a starter unit which includes a coded infeed. Add additional middle or end units as required.
- Middle and end units are equipped with connecting cables.
- In-surface modules require table top cut-outs for mounting. Please specify TR - Top Right and/or TL - Top Left.

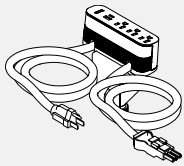
GMDSA10 • ModPower Starter Mounted Unit

- ModPower starter unit includes one 10' cord with a NEMA plug and one 3' connector cord.
- Unit equipped with three 15A tamper resistant receptacles, one USB-A and one USB-C charging ports and a circuit breaker.
- Includes edge clamp and 3 other mounting methods; and 4 cable management cord clips.
- MG at the end of the code indicates a magnesium finish, while WH is a white finish.

PRODUCT CODE	PRICE	SIZE/INCHES			WEIGHT LBS	VOL FT ³
		H	W	D		
GMDSA10MG	806	6.13	1.75	2.5	4.33	1.0
GMDSA10WH	806	6.13	1.75	2.5	4.33	1.0

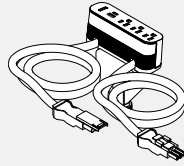
GMDCA3 • ModPower Middle Mounted Unit

- ModPower middle unit includes two 3' connector cords.
- Unit equipped with three 15A rated 12A tamper resistant receptacles, one USB-A and one USB-C charging ports and a circuit breaker.
- Includes edge clamp and 3 other mounting methods; and 4 cable management cord clips.
- MG at the end of the code indicates a magnesium finish, while WH is a white finish.

PRODUCT CODE	PRICE	SIZE/INCHES			WEIGHT LBS	VOL FT ³
		H	W	D		
GMDCA3MG	763	6.13	1.75	2.5	3.33	1.0
GMDCA3WH	763	6.13	1.75	2.5	3.33	1.0

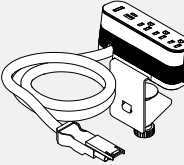
GMDEA3 • ModPower End Mounted Unit

- ModPower end unit includes one 3' connector cord.
- Unit equipped with three 15A rated 12A tamper resistant receptacles, one USB-A and one USB-C charging ports and a circuit breaker.
- Includes edge clamp and 3 other mounting methods; and 2 cable management cord clips.
- MG at the end of the code indicates a magnesium finish, while WH is a white finish.

PRODUCT CODE	PRICE	SIZE/INCHES			WEIGHT LBS	VOL FT ³
		H	W	D		
GMDEA3MG	675	6.13	1.75	2.5	2.75	1.0
GMDEA3WH	675	6.13	1.75	2.5	2.75	1.0

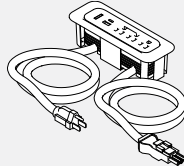
GMDSF10 • ModPower In Surface Starter Unit

- ModPower starter unit includes one 10' cord with a NEMA plug and one 3' connector cord.
- Unit equipped with three 15A tamper resistant receptacles, one USB-A and one USB-C charging ports and a circuit breaker.
- 4 cable management cord clips included.
- MG at the end of the code indicates a magnesium finish, while WH is a white finish.

PRODUCT CODE	PRICE	SIZE/INCHES			WEIGHT LBS	VOL FT ³
		H	W	D		
GMDSF10MG	597	2.63	7.63	2.63	3.44	1.0
GMDSF10WH	597	2.63	7.63	2.63	3.44	1.0

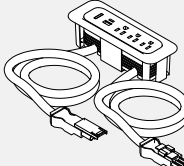
GMDCF3 • ModPower In Surface Middle Unit

- ModPower middle unit includes two 3' connector cords.
- Unit equipped with three 15A rated 12A tamper resistant receptacles, one USB-A and one USB-C charging ports and a circuit breaker.
- 4 cable management cord clips included.
- MG at the end of the code indicates a magnesium finish, while WH is a white finish.

PRODUCT CODE	PRICE	SIZE/INCHES			WEIGHT LBS	VOL FT ³
		H	W	D		
GMDCF3MG	562	2.63	7.63	2.63	2.44	1.0
GMDCF3WH	562	2.63	7.63	2.63	2.44	1.0

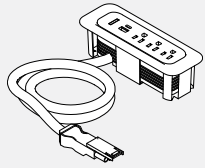
GMDEF3 • ModPower In Surface End Unit

- ModPower end unit includes one 3' connector cord.
- Unit equipped with three 15A rated 12A tamper resistant receptacles, one USB-A and one USB-C charging ports and a circuit breaker.
- 2 cable management cord clips included.
- MG at the end of the code indicates a magnesium finish, while WH is a white finish.

PRODUCT CODE	PRICE	SIZE/INCHES			WEIGHT LBS	VOL FT ³
		H	W	D		
GMDEF3MG	494	2.63	7.63	2.63	1.85	1.0
GMDEF3WH	494	2.63	7.63	2.63	1.85	1.0

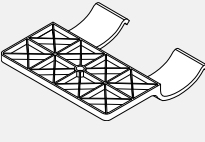
GMDCLIPS • ModPower Management Clips

- Includes 10 clips.

PRODUCT CODE	PRICE	SIZE/INCHES			WEIGHT LBS	VOL FT ³
		H	W	D		
GMDCLIPS	131	2.6	2.5	0.6	0.3	0.2

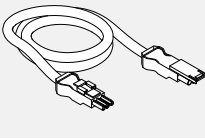
GMDJ36BK • ModPower Interconnecting Jumper

- ModPower interconnecting jumper cord to add an additional 3 feet of cord length between ModPower units.
- Package of 2, each 3 feet with male & female connector.

PRODUCT CODE	PRICE	SIZE/INCHES			WEIGHT LBS	VOL FT ³
		H	W	D		
GMDJ36BK	422	36			1.38	0.9

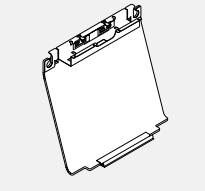
HXEPK • Station 2-Circuit Power Kit

- Station 2-Circuit Power Kit consists of two duplexes, trough, cable shroud and divider grommet.
- Accommodates up to two standard data plates (plates not included).
- Accommodates center mount single or dual screen monitor arm.
- Facilitates 2-circuit power delivery.
- Facilitates interconnection of two stations. Please specify Station to Station Jumper.
- Specify duplex circuit #1, #2 or combination #1+2.
- Ceiling or base feed not included, please specify separately.
- Trough is powder coated metal in CHR - Charcoal.
- Includes all connecting hardware, supporting brackets and through divider grommet.
- PET Felt finish, please chose from any standard PET Felt.

PRODUCT CODE	PRICE	SIZE/INCHES			WEIGHT LBS	VOL FT ³
		H	W	D		
HXEPK11	311	20.85	23.5	9.73	3.92	2.76
HXEPK12	311	20.85	23.5	9.73	3.92	2.76
HXEPK22	311	20.85	23.5	9.73	3.92	2.76

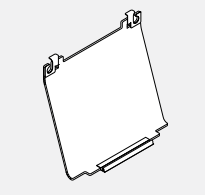
HXECS • Cable Shroud

- Cable shroud secures to the bottom of worksurface and clips to the bottom of straight section of any divider.
- Includes all connecting hardware.
- PET Felt finish, please chose from any standard PET Felt.

PRODUCT CODE	PRICE	SIZE/INCHES			WEIGHT LBS	VOL FT ³
		H	W	D		
HXECS	76	1	22	8	1.62	2.87

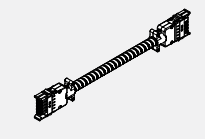
HXEPPJ • Station to Station Jumper

- Station to station jumper.
- Facilitates interconnection of two stations (through divider grommet, under the worksurface).

PRODUCT CODE	PRICE	SIZE/INCHES			WEIGHT LBS	VOL FT ³
		H	W	D		
HXEPPJ	120	2	60	2	5	0.13

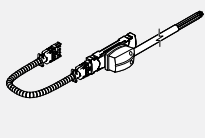
HXEBF • Base Feed

- Base feed provides single power entry from floor into 2-Circuit Power Kit under worksurface.
- 6' long liquid tight whip; ready to be hardwired to building power supply.

PRODUCT CODE	PRICE	SIZE/INCHES			WEIGHT LBS	VOL FT ³
		H	W	D		
HXEBF	354	2	72	2	5.6	0.06

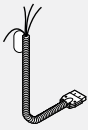
HXECEF • Ceiling Feed

- Ceiling feed plugs into left or right duplex mounted within the 2-Circuit Power Kit.
- 10' long metal conduit, ready to be hardwired to building power supply.
- Strain relief fitting provided; junction box is not included.
- To be used with HXEFCF - Ceiling Feed Pole

PRODUCT CODE	PRICE	SIZE/INCHES			WEIGHT LBS	VOL FT ³
		H	W	D		
HXECEF	178	2	144	2	5.6	0.06

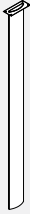
HXEFCF • Ceiling Feed Pole

- Ceiling Feed Pole manages power and data cables between ceiling and worksurface.
- Aluminum extrusion with PVC cover secures to the divider grommet and passes below worksurface through the worksurface contoured recess.
- Mounting hardware and ceiling bezel included.
- Hardware for securing the pole above ceiling tile is not included.
- Please specify standard paint finish.
- PVC colour CHR - Charcoal.
- Ceiling Feed HXECEF must be ordered separately.

PRODUCT CODE	PRICE	SIZE/INCHES			WEIGHT LBS	VOL FT ³
		H	W	D		
HXEFCF	150	116	6	1.5	5.49	0.38

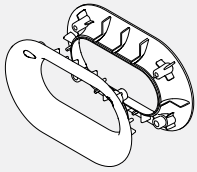
HXEFGK • Divider Grommet Kit

- Divider Grommet Kit facilitates passage of wires through any Softpod divider.
- Can be located either below or above the worksurface.
- Installed on site; no need to order special dividers.
- Powder coated die-cast aluminum divider grommet - specify CHR - Charcoal or WHT (OR DWT)

PRODUCT CODE	PRICE	SIZE/INCHES			WEIGHT LBS	VOL FT ³
		H	W	D		
HXEFGK	29	3.25	5.5	2.75	0.27	0.02

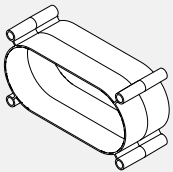
HXEFGCS • Divider Grommet Connector / Spacer

- Divider Grommet Spacer converts any Divider Grommet Kit into a connector.
- Clamps two dividers together through the divider grommet opening.
- Can be located above or below the worksurface at pre-determined locations.
- Specify with the Divider Grommet Kit or use with the Divider Grommet Kit included in the Station 2-Circuit Power Kit.
- Made of injection molded ABS in CHR - Charcoal.
- For Dual Pod connection, only 1 HXEFGK is needed.

PRODUCT CODE	PRICE	SIZE/INCHES			WEIGHT LBS	VOL FT ³
		H	W	D		
HXEFGCS	13	3.25	5.5	2.75	0.04	0.01

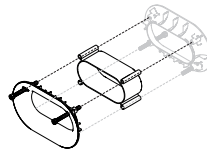

HXSCSO • Under Worksurface Casual Storage Unit

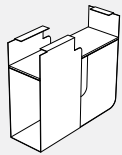

- Open storage with shelf; extension at the back provides side compartment.
- Sheet metal construction with PET liner; 24" deep
- Secured to the bottom of worksurface.
- Choose from standard PET and panel frame finishes.
- Order coat hook HXACHS, attaches to either left or right side of storage unit (sold separately).

PRODUCT CODE	PRICE	SIZE			WEIGHT LBS	VOL FT ³
		H	W	D		
HXSCSO	327	21	8	24	20.18	4.22

L2PO • Pantry Storage

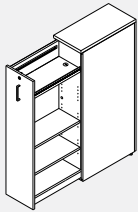

Left Hand Shown

- The pull out cabinet serves as a multifunction, customizable storage unit that both defines space and enhances privacy in an open plan environment.
- Can be used in conjunction with Licence, Bridges, FreeFit and Boulevard.
- Internal organization consists of two fixed shelves top and bottom. The two middle shelves are adjustable. Two accessory rails are standard and will accept GC metal accessories
- Interior cabinet shelves and back are standard in Designer White. Cabinet shell, drawer and top can be specified in any standard laminate.
- L2PO12-NL/R does not fit binders.
- Only available with FA handle.

PRODUCT CODE	PRICE LP	B	W	SIZE/INCHES				WEIGHT LBS	VOL FT ³
				H(LP/B)	H(W)	W	D		
L2PO1224H54NL	1691	1709	1741	53.56	54	12	24	138	9
L2PO1230H54NL	1772	1792	1813	53.56	54	12	30	153	11
L2PO1236H54NL	1853	1878	1904	53.56	54	12	36	167	14
L2PO1824H54NL	1961	1986	2029	53.56	54	18	24	166	14
L2PO1830H54NL	2049	2081	2131	53.56	54	18	30	182	17
L2PO1836H54NL	2137	2173	2233	53.56	54	18	36	197	20
L2PO1224H54NR	1691	1709	1741	53.56	54	12	24	138	9
L2PO1230H54NR	1772	1792	1813	53.56	54	12	30	153	11
L2PO1236H54NR	1853	1878	1904	53.56	54	12	36	167	14
L2PO1824H54NR	1961	1986	2029	53.56	54	18	24	166	14
L2PO1830H54NR	2049	2081	2131	53.56	54	18	30	182	17
L2PO1836H54NR	2137	2173	2233	53.56	54	18	36	197	20

Finish

While the Pantry Storage cabinet walls, top and pull-out drawer front door and back panel finish can be specified, the internal cabinet back and adjustable shelves are standard white. Please specify the cabinet top and pull-out drawer front finish.

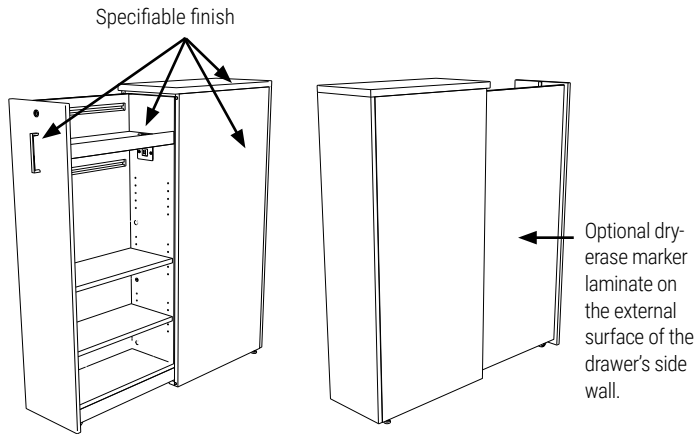

Options

- Dual USB A+C outlet kit - please add "USB" at the end of the code. Add \$388 to the list price
- When you specify dual USB outlet the top shelf will come with grey PET Felt surface and grommet which allows for cable passage from the USB outlet (located below the top shelf). A two-prong power cord exits the cabinet through the floor at the back.
- Dry-erase marker board - Choose "DE" option. Please add \$372 to the list price. If specified the Dry-erase marker laminate will be applied to the external surface of the pull-out drawer side wall.

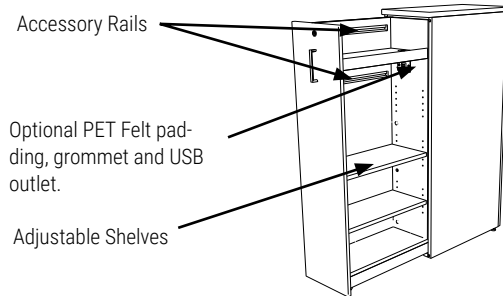

Integrated Accessory rails

Two accessory rails (each 18.25" long) are provided to further enhance customization with Global Contract metal accessories.

Upper Accessory Rail:

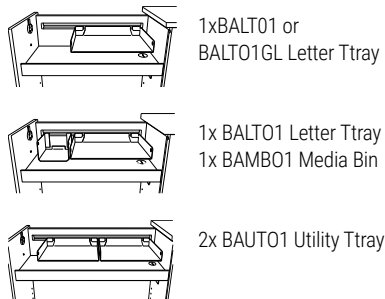

Lower Accessory Rail:

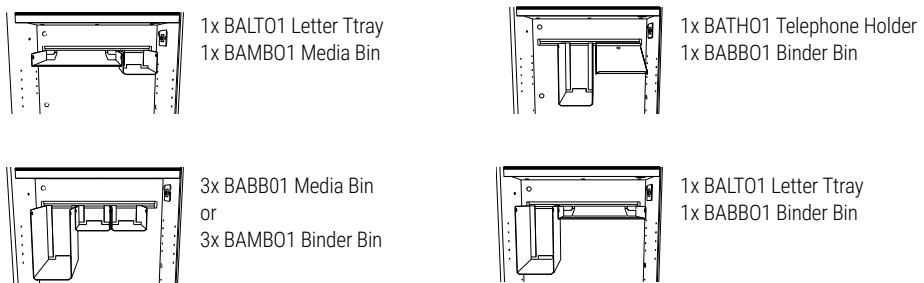

L2PW • Wardrobe Pantry Storage

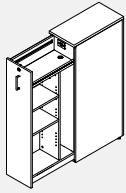

Left Hand Shown

- The pull out cabinet serves as a multifunction, customizable storage unit that both defines space and enhances privacy in an open plan environment.
- Can be used in conjunction with Licence,, FreeFit and Boulevard.
- Internal organization consists of one fixed shelf at the top. The two middle shelves are adjustable. Wardrobe includes coat hook.
- Interior cabinet shelves and back are standard in Designer White. Cabinet shell, drawer and top can be specified in any standard laminate.
- L2PW12-NL/R does not fit binders.
- Only available with FA handle.

Finish

While the Pantry Storage cabinet walls, top and pull-out drawer front door and back panel finish can be specified, the internal cabinet back and adjustable shelves are standard white. Please specify the cabinet top and pull-out drawer front finish.

Options

- Dual USB A+C outlet kit - please add "USB" at the end of the code. Add \$388 to the list price
- When you specify dual USB outlet the top shelf will come with grey felt surface and grommet which allows for cable passage from the USB outlet (located below the top shelf). A two-prong power cord exits the cabinet through the floor at the back.
- Dry-erase marker board - Choose "DE" option. Please add \$372 to the list price. If specified the Dry-erase marker laminate will be applied to the external surface of the pull-out drawer side wall.

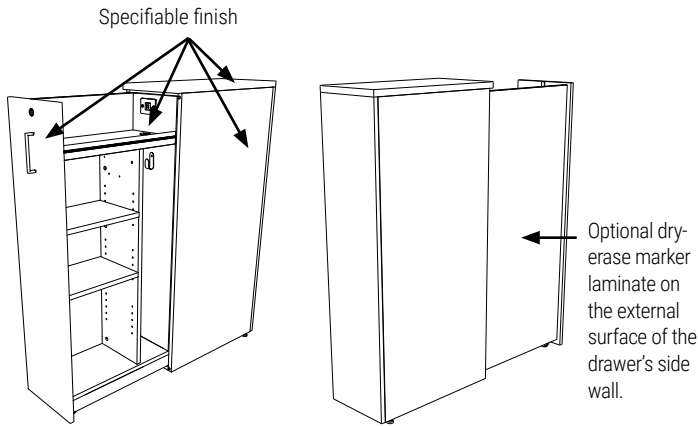

PRODUCT CODE	PRICE LP	SIZE/INCHES				WEIGHT LBS	VOL FT ³		
		B	W	H(LP/B)	H(W)				
L2PW1224H42NL	1680	1698	1735	41.56	42	12	24	128	7
L2PW1230H42NL	1757	1780	1822	41.56	42	12	30	143	9
L2PW1236H42NL	1832	1860	1911	41.56	42	12	36	157	11
L2PW1824H42NL	1946	1975	2022	41.56	42	18	24	156	11
L2PW1830H42NL	2031	2066	2124	41.56	42	18	30	172	13
L2PW1836H42NL	2116	2158	2225	41.56	42	18	36	187	16
L2PW1224NL	1831	1848	1880	49.56	50	12	24	133	8
L2PW1230NL	1912	1945	1971	49.56	50	12	30	148	10
L2PW1236NL	1993	2040	2064	49.56	50	12	36	162	15
L2PW1824NL	2140	2173	2207	49.56	50	18	24	161	12
L2PW1830NL	2227	2281	2310	49.56	50	18	30	177	15
L2PW1836NL	2315	2388	2412	49.56	50	18	36	192	18
L2PW1224H54NL	1866	1884	1916	53.56	54	12	24	138	9
L2PW1230H54NL	1947	1967	1988	53.56	54	12	30	153	11
L2PW1236H54NL	2028	2053	2080	53.56	54	12	36	167	14
L2PW1824H54NL	2182	2206	2250	53.56	54	18	24	166	14
L2PW1830H54NL	2269	2301	2351	53.56	54	18	30	182	17
L2PW1836H54NL	2358	2394	2453	53.56	54	18	36	197	20
L2PW1224H42NR	1680	1698	1735	41.56	42	12	24	128	7
L2PW1230H42NR	1757	1780	1822	41.56	42	12	30	143	9
L2PW1236H42NR	1832	1860	1911	41.56	42	12	36	157	11
L2PW1824H42NR	1946	1975	2022	41.56	42	18	24	156	11
L2PW1830H42NR	2031	2066	2124	41.56	42	18	30	172	13
L2PW1836H42NR	2116	2158	2225	41.56	42	18	36	187	16
L2PW1224NR	1831	1848	1880	49.56	50	12	24	133	8
L2PW1230NR	1912	1945	1971	49.56	50	12	30	148	10
L2PW1236NR	1993	2040	2064	49.56	50	12	36	162	15
L2PW1824NR	2140	2173	2207	49.56	50	18	24	161	12
L2PW1830NR	2227	2281	2310	49.56	50	18	30	177	15
L2PW1836NR	2315	2388	2412	49.56	50	18	36	192	18
L2PW1224H54NR	1866	1884	1916	53.56	54	12	24	138	9
L2PW1230H54NR	1947	1967	1988	53.56	54	12	30	153	11
L2PW1236H54NR	2028	2053	2080	53.56	54	12	36	167	14
L2PW1824H54NR	2182	2206	2250	53.56	54	18	24	166	14
L2PW1830H54NR	2269	2301	2351	53.56	54	18	30	182	17
L2PW1836H54NR	2358	2394	2453	53.56	54	18	36	197	20

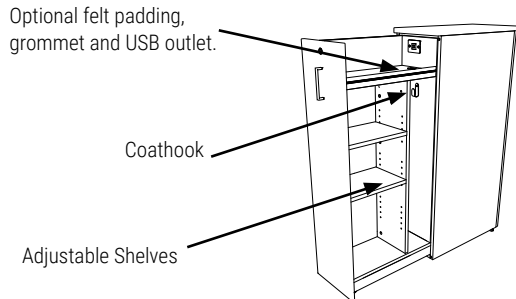

L2PSB • Pantry Felt Storage Bin

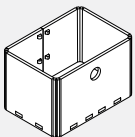

- Crafted from recycled PET felt, felt bins are an intuitive and versatile organization solution within your Pantry unit.
- Felt is 9mm, please choose from our 18 difference finishes.

PRODUCT CODE	PRICE	SIZE/INCHES			WEIGHT LBS	VOL FT ³
		H	W	D		
L2PSB0912	47	7.5	11.8	8.6	0.30	0.44

L2PST • Pantry Felt Storage Tray

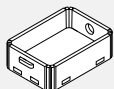

- Crafted from recycled PET felt, felt bins are an intuitive and versatile organization solution within your Pantry unit.
- Felt is 9mm, please choose from our 18 difference finishes.

PRODUCT CODE	PRICE	SIZE/INCHES			WEIGHT LBS	VOL FT ³
		H	W	D		
L2PST0609	18	2.6	8.6	5.9	0.28	0.08

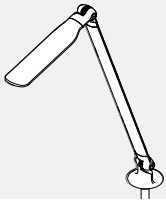
BLVELEDVS • LED Single Arm Lamp

- **7 System watts, 18-fractional LEDs.**
- 3500K 250 lumens, 84 CRI.
- Soft touch - instant on, fade to off.
- Infinite dimming 100% down to 15%, last state memory.
- Standard 10 hours turn off (ATO).
- 50,000 hour life LEDs.
- 15 watt, 24 volt wall transformer, 6' cord.
- White (WHT) Silver (SIL) or Black (BLK) - Must specify colour choice.
- UL, CUL and CSA compliant, ETL Listed.
- Base not included.

PRODUCT CODE	PRICE	SIZE/ H	INCHES W	D	WEIGHT LBS	VOL FT ³
BLVELEDVS	616				3	0.93
With Occupancy Sensor						
BLVELEDVSO	920				3	0.93

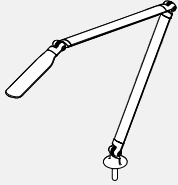
BLVELEDVD • LED Double Arm Lamp

- **7 System watts, 18-fractional LEDs.**
- 3500K 250 lumens, 84 CRI.
- Double arm articulation with 20" base to head reaches.
- Soft touch - instant on, fade to off.
- Infinite dimming 100% down to 15%, last state memory.
- Standard 10 hours turn off (ATO).
- 50,000 hour life LEDs.
- 15 watt, 24 volt wall transformer, 6' cord.
- White (WHT) Silver (SIL) or Black (BLK) - Must specify colour choice.
- UL, CUL and CSA compliant, ETL Listed.
- Base not included.

PRODUCT CODE	PRICE	SIZE/ H	INCHES W	D	WEIGHT LBS	VOL FT ³
BLVELEDVD	646				3	0.93
With Occupancy Sensor						
BLVELEDVDO	931				3	0.93

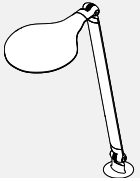
BLVELEDRS • LED Single Arm Lamp

- **7 System watts, 18-fractional LEDs.**
- 3500K 250 lumens, 84 CRI.
- Soft touch - instant on, fade to off.
- Infinite dimming 100% down to 15%, last state memory.
- Standard 10 hours turn off (ATO).
- 50,000 hour life LEDs.
- 15 watt, 24 volt wall transformer, 6' cord.
- White (WHT) Silver (SIL) or Black (BLK) - Must specify colour choice.
- UL, CUL and CSA compliant, ETL Listed.
- Base not included.

PRODUCT CODE	PRICE	SIZE/ H	INCHES W	D	WEIGHT LBS	VOL FT ³
BLVELEDRS	616				3	0.93
With Occupancy Sensor						
BLVELEDRSO	920				3	0.93

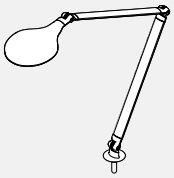
BLVELEDRD • LED Double Arm Lamp

- **7 System watts, 18-fractional LEDs.**
- 3500K 250 lumens, 84 CRI.
- Double arm articulation with 20" base to head reaches.
- Soft touch - instant on, fade to off.
- Infinite dimming 100% down to 15%, last state memory.
- Standard 10 hours turn off (ATO).
- 50,000 hour life LEDs.
- 15 watt, 24 volt wall transformer, 6' cord.
- White (WHT) Silver (SIL) or Black (BLK) - Must specify colour choice.
- UL, CUL and CSA compliant, ETL Listed.
- Base not included.

PRODUCT CODE	PRICE	SIZE/ H	INCHES W	D	WEIGHT LBS	VOL FT ³
BLVELEDRD	633				3	0.93
With Occupancy Sensor						
BLVELEDRDO	931				3	0.93

Lamp Mounting Options

- White (WHT) Silver (SIL) or Black (BLK) - Must specify colour choice.



Worksurface Clamp Mount						
PRODUCT CODE	PRICE	SIZE/ H	INCHES W	D	WEIGHT LBS	VOL FT ³
BLVELEDASCM	155				1	0.05

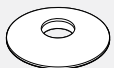

Freestanding Base						
PRODUCT CODE	PRICE	SIZE/ H	INCHES W	D	WEIGHT LBS	VOL FT ³
BLVELEDAFS	173				3	0.5

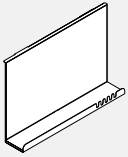
HXAHS • Hanging Shelf

- Hanging Shelf for personal item storage.
- Suspended from the divider's top reveal.
- Installed board measures 16" from top; 9" from top of worksurface.
- Painted metal, choose from standard panel frame finishes.
- Choose a PET Felt finish for the tray insert.

PRODUCT CODE	PRICE			WEIGHT		VOL FT ³
	H	W	D	LBS		
HXAHS	104	16	23.5	3	8.8	1.91

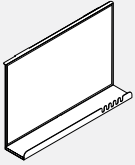
HXAHSWB • Hanging Shelf with Dry Erase Board

- Hanging shelf with, dry-erase marker surface.
- Suspended from the divider's top reveal.
- Installed board measures 16" from top; 9" from top of worksurface.
- White surface, painted metal frame; choose from standard panel frame finishes.
- Choose a PET Felt finish for the tray insert.

PRODUCT CODE	PRICE			WEIGHT		VOL FT ³
	H	W	D	LBS		
HXAHSWB	398	16	23.5	3	9.57	1.91

HXARWS • Rear Wall Shelf

- Rear wall laminate shelf.
- Made of 3/4" LP- low pressure or HP - high pressure; non-handed, with pre-determined mounting points.
- 2.5" front radii.
- Choose from standard laminate finishes, PVC edge.
- NOTE: Not compatible with Ceiling Feed Pole or any monitor mounts.

PRODUCT CODE	PRICE			WEIGHT		VOL FT ³
	LP	HP	H	W	D	
HXARWS	106	135	0.75	32.25	4.5	1.13

HXACHS • Coat/Bag Hook for Dividers

- Coat/Bag Hook can be installed anywhere along the divider perimeter reveal or either side of the Under Surface Casual Storage Unit.
- Made of die-cast aluminum, specify any standard metal paint finish.
- Choose a PET Felt finish for the plug insert.

PRODUCT CODE	PRICE			WEIGHT		VOL FT ³
	H	W	D	LBS		
HXACHS	30	2	1.25	0.75	0.05	0.01

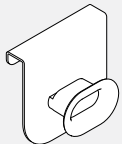
HXACHT • Coat/Bag Hook for Dividers Edge

- Coat/Bag Hook can be installed anywhere along the divider perimeter reveal or either or both sides of any divider.
- Made of die-cast aluminum with steel brackets, specify any standard metal paint finish.
- Choose a PET Felt finish for the plug insert.

PRODUCT CODE	PRICE			WEIGHT		VOL FT ³
	H	W	D	LBS		
HXACHT	35	2	1.25	0.75	0.23	0.01

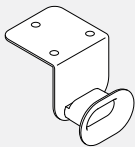
HXABH • Under Surface Bag Hook

- Under Surface Bag Hook can be secured to the bottom of worksurface.
- Made of die-cast aluminum with steel brackets, specify any standard metal paint finish.
- Choose a PET Felt finish for the plug insert.

PRODUCT CODE	PRICE			WEIGHT		VOL FT ³
	H	W	D	LBS		
HXABH	33	2	1.25	0.75	0.18	0.01

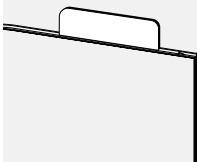
HXNP • Name Plate

- Name Plate sits inside the divider top reveal.
- Two-sided white dry erase surface laminated to 1/2" PET Felt.

PRODUCT CODE	PRICE			WEIGHT		VOL FT ³
	H	W	D	LBS		
HXNP	60	3.625	10.75	0.5		0.01

GCPPVACH • Universal Polypropylene Divider Panels - H Configuration

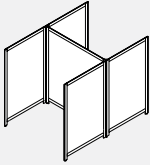

- **Universal Polypropylene Divider Panels dividing space with flexibility.**
- Lightweight and easy to clean partitions.
- Minimal footprint for storage.
- Fluted solid white polypropylene screens surrounded by a 1/2" by 2/5" powder coated aluminum frame in DWT - Designer White or TUN - Tungsten
- Charcoal soft touch radius end trim.
- 7" panel opening at panel bottom for easy cleaning and cable pass-thru.
- Includes all connecting hardware and 1" levelling glide.
- Stations are 60" wide by 42" deep by 66" high.
- Planning stations are preconfigured in a back-to-back H with ability to add stations with a T configuration.

PRODUCT CODE	PRICE	SIZE/INCHES			WEIGHT LBS	VOL FT ³
		H	W	D		
GCPPVACH666085	1945	66	60	85	90	18.74

GCPPVACT • Universal Polypropylene Divider Panels - T Configuration

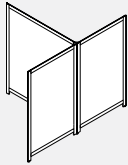

- **Universal Polypropylene Divider Panels dividing space with flexibility.**
- Lightweight and easy to clean partitions.
- Minimal footprint for storage.
- Fluted solid white polypropylene screens surrounded by a 1/2" by 2/5" powder coated aluminum frame in DWT - Designer White or TUN - Tungsten
- Charcoal soft touch radius end trim.
- 7" panel opening at panel bottom for easy cleaning and cable pass-thru.
- Includes all connecting hardware and 1" levelling glide.
- Stations are 60" wide by 42" deep by 66" high.
- Planning stations are preconfigured in a back-to-back H with ability to add stations with a T configuration.

PRODUCT CODE	PRICE	SIZE/INCHES			WEIGHT LBS	VOL FT ³
		H	W	D		
GCPPVACT666085	1238	66	60	85	73	11.82

GCPPVACU • Universal Polypropylene Divider Panels - U Configuration

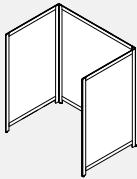

- **Universal Polypropylene Divider Panels dividing space with flexibility.**
- Lightweight and easy to clean partitions.
- Minimal footprint for storage.
- Fluted solid white polypropylene screens surrounded by a 1/2" by 2/5" powder coated aluminum frame in DWT - Designer White or TUN - Tungsten
- Charcoal soft touch radius end trim.
- 7" panel opening at panel bottom for easy cleaning and cable pass-thru.
- Includes all connecting hardware and 1" levelling glide.
- Stations are 60" wide by 42" deep by 66" high.
- Planning stations are preconfigured in a back-to-back U with ability to add stations with an L configuration.

PRODUCT CODE	PRICE	SIZE/INCHES			WEIGHT LBS	VOL FT ³
		H	W	D		
GCPPVACU666043	1241	66	60	43	73	11.82

GCPPVACL • Universal Polypropylene Divider Panels - L Configuration

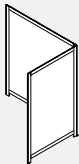

- **Universal Polypropylene Divider Panels dividing space with flexibility.**
- Lightweight and easy to clean partitions.
- Minimal footprint for storage.
- Fluted solid white polypropylene screens surrounded by a 1/2" by 2/5" powder coated aluminum frame in DWT - Designer White or TUN - Tungsten
- Charcoal soft touch radius end trim.
- 7" panel opening at panel bottom for easy cleaning and cable pass-thru.
- Includes all connecting hardware and 1" levelling glide.
- Stations are 60" wide by 42" deep by 66" high.
- Planning stations are preconfigured in a back-to-back U with ability to add stations with an L configuration.

PRODUCT CODE	PRICE	SIZE/INCHES			WEIGHT LBS	VOL FT ³
		H	W	D		
GCPPVACL666043	885	66	60	43	58	8.36

GCUPFSP • Freestanding Divider Polycarbonate Screen With Flat Feet

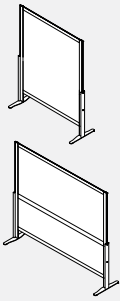

- Provides privacy and room separation.
- Lightweight and easy to clean and move.
- Consists of a powder coated aluminum frame, translucent fluted polycarbonate and steel flat feet.
- Option for 54", 60 and 72" high.
- 72" high by 60" wide divider has a crossbar in the middle.
- Please choose any standard paint finish for frame and feet.

PRODUCT CODE	PRICE	SIZE/INCHES			WEIGHT LBS	VOL FT ³
		H	W	D		
GCUPFSP5424	485	51.75	24	20	15.96	14.38
GCUPFSP5430	534	51.75	30	20	17.96	17.97
GCUPFSP5436	577	51.75	36	20	19.96	21.56
GCUPFSP5442	625	51.75	42	20	21.96	25.16
GCUPFSP5448	632	51.75	48	20	20.96	28.75
GCUPFSP5460	763	51.75	60	20	22.96	35.94
GCUPFSP6024	496	57.75	24	20	17.96	16.04
GCUPFSP6030	543	57.75	30	20	19.96	20.05
GCUPFSP6036	587	57.75	36	20	21.96	24.06
GCUPFSP6042	634	57.75	42	20	23.96	28.07
GCUPFSP6048	644	57.75	48	20	25.96	32.08
GCUPFSP6060	775	57.75	60	20	27.96	40.10
GCUPFSP7230	626	69.75	30	20	21.96	24.22
GCUPFSP7236	683	69.75	36	20	23.96	29.06
GCUPFSP7242	759	69.75	42	20	25.96	33.91
GCUPFSP7248	766	69.75	48	20	27.96	38.75
GCUPFSP7260	884	69.75	60	20	29.96	48.44

GCUPMSP • Freestanding Divider Polycarbonate Screen With Casters

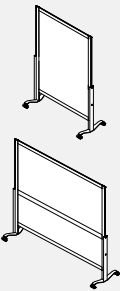

- Provides privacy and room separation.
- Lightweight and easy to clean and move.
- Consists of a powder coated aluminum frame, translucent fluted polycarbonate and steel feet with casters.
- Option for 54", 60 and 72" high.
- 72" high by 60" wide divider has a crossbar in the middle.
- Please choose any standard paint finish for frame and feet.

PRODUCT CODE	PRICE	SIZE/INCHES			WEIGHT LBS	VOL FT ³
		H	W	D		
GCUPMSP5424	718	52.05	24	20	17.13	14.46
GCUPMSP5430	766	52.05	30	20	19.13	18.07
GCUPMSP5436	748	52.05	36	20	21.13	21.69
GCUPMSP5442	794	52.05	42	20	23.13	25.30
GCUPMSP5448	801	52.05	48	20	22.13	28.92
GCUPMSP5460	922	52.05	60	20	24.13	36.15
GCUPMSP6024	675	58.05	24	20	19.13	16.13
GCUPMSP6030	718	58.05	30	20	21.13	20.16
GCUPMSP6036	759	58.05	36	20	23.13	24.19
GCUPMSP6042	803	58.05	42	20	25.13	28.22
GCUPMSP6048	812	58.05	48	20	27.13	32.25
GCUPMSP6060	932	58.05	60	20	29.13	40.31
GCUPMSP7230	918	70.05	30	20	23.13	24.32
GCUPMSP7236	858	70.05	36	20	25.13	29.19
GCUPMSP7242	917	70.05	42	20	27.13	34.05
GCUPMSP7248	925	70.05	48	20	29.13	38.92
GCUPMSP7260	1033	70.05	60	20	31.13	48.65

GCUPSHS • Shared Divider Polycarbonate Screen

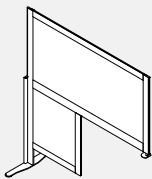

- Provides privacy and divides space for workstations.
- Divider stands on the floor and sits on the work surface.
- Has no mechanical connection to any surface.
- Lightweight and easy to clean and move.
- Consists of a powder coated aluminum frame, translucent fluted polycarbonate and steel flat foot.
- Option for 54" and 60" high.
- Extends 24" from the work surface.
- Sits 24" or 30" above work surface.
- Please choose any standard paint finish for frame and feet.

PRODUCT CODE	PRICE	SIZE/INCHES			WEIGHT LBS	VOL FT ³
		H	W	D		
GCUPSHS5448	499	53.57	48	20	13.45	29.76
GCUPSHS5454	521	53.57	54	20	15.45	33.48
GCUPSHS6048	541	59.57	48	20	17.45	33.09
GCUPSHS6054	568	59.57	54	20	19.45	37.23

GCUPFSF • Freestanding Divider Felt Screen With Flat Feet

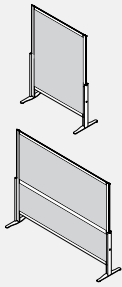

- Provides privacy and room separation.
- Lightweight and easy to clean and move.
- Consists of a powder coated aluminum frame, felt and steel flat feet.
- Option for 54", 60 and 72" high.
- 72" high by 60" wide divider has a crossbar in the middle.
- Please choose any standard paint finish for frame and feet.

PRODUCT CODE	PRICE	SIZE/INCHES			WEIGHT LBS	VOL FT ³
		H	W	D		
GCUPFSF5424	435	51.75	24	20	19.58	14.38
GCUPFSF5430	459	51.75	30	20	20.32	17.97
GCUPFSF5436	468	51.75	36	20	21.06	21.56
GCUPFSF5442	491	51.75	42	20	21.8	25.16
GCUPFSF5448	500	51.75	48	20	22.54	28.75
GCUPFSF5460	614	51.75	60	20	24.03	35.94
GCUPFSF6024	444	57.75	24	20	20.38	16.04
GCUPFSF6030	471	57.75	30	20	21.11	20.05
GCUPFSF6036	478	57.75	36	20	21.84	24.06
GCUPFSF6042	507	57.75	42	20	22.57	28.07
GCUPFSF6048	510	57.75	48	20	23.3	32.08
GCUPFSF6060	623	57.75	60	20	24.87	40.10
GCUPFSF7230	522	69.75	30	20	22.42	24.22
GCUPFSF7236	530	69.75	36	20	23.24	29.06
GCUPFSF7242	621	69.75	42	20	24.06	33.91
GCUPFSF7248	629	69.75	48	20	24.88	38.75
GCUPFSF7260	785	69.75	60	20	29.79	48.44

GCUPMSF • Freestanding Felt Divider Screen With Casters

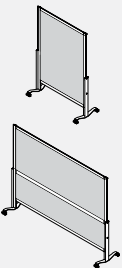

- Provides privacy and room separation.
- Lightweight and easy to clean and move.
- Consists of a powder coated aluminum frame, felt and steel feet with casters.
- Option for 54", 60 and 72" high.
- 72" high by 60" wide divider has a crossbar in the middle.
- Please choose any standard paint finish for frame and feet.

PRODUCT CODE	PRICE	SIZE/INCHES			WEIGHT LBS	VOL FT ³
		H	W	D		
GCUPMSF5424	618	52.05	24	20	20.76	14.46
GCUPMSF5430	641	52.05	30	20	21.5	18.07
GCUPMSF5436	648	52.05	36	20	22.24	21.69
GCUPMSF5442	671	52.05	42	20	22.98	25.30
GCUPMSF5448	678	52.05	48	20	23.72	28.92
GCUPMSF5460	784	52.05	60	20	25.21	36.15
GCUPMSF6024	627	58.05	24	20	21.47	16.13
GCUPMSF6030	650	58.05	30	20	22.23	20.16
GCUPMSF6036	657	58.05	36	20	22.99	24.19
GCUPMSF6042	680	58.05	42	20	23.75	28.22
GCUPMSF6048	688	58.05	48	20	24.51	32.25
GCUPMSF6060	792	58.05	60	20	26.05	40.31
GCUPMSF7230	699	70.05	30	20	23.6	24.32
GCUPMSF7236	709	70.05	36	20	24.42	29.19
GCUPMSF7242	790	70.05	42	20	25.24	34.05
GCUPMSF7248	797	70.05	48	20	26.06	38.92
GCUPMSF7260	942	70.05	60	20	30.97	48.65

GCUPSHF • Shared Divider Felt Screen

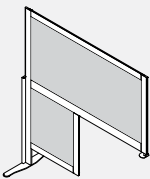

- Provides privacy and divides space for workstations.
- Divider stands on the floor and sits on the worksurface.
- Has no mechanical connection to any surface.
- Lightweight and easy to clean and move.
- Consists of a powder coated aluminum frame, translucent fluted polycarbonate and steel flat foot.
- Option for 54" and 60" high.
- Extends 24" from the worksurface.
- Sits 24" or 30" above worksurface.
- Please choose any standard paint finish for frame and feet.

PRODUCT CODE	PRICE	SIZE/INCHES			WEIGHT LBS	VOL FT ³
		H	W	D		
GCUPSHF5448	411	53.57	48	20	18.06	29.76
GCUPSHF5454	469	53.57	54	20	18.8	33.48
GCUPSHF6048	438	59.57	48	20	18.84	33.09
GCUPSHF6054	578	59.57	54	20	19.6	37.23

GCUPFSG • Freestanding Divider Glass Screen with Flat Feet

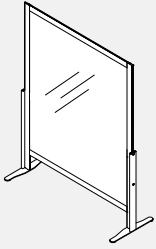

- Provides privacy and room separation.
- Lightweight and easy to clean and move.
- Consists of an aluminum frame, clear glass screen and steel flat feet.
- Please choose any standard panel frame paint finish from Global Contract for all metal parts.
- Option for 54" / 60" high.
- Upcharge for frosted (FRST) glass is 20%.

PRODUCT CODE	PRICE	SIZE/INCHES			WEIGHT LBS	VOL FT ³
		H	W	D		
GCUPFSG5424	570	51.75	24	20	30.83	14.38
GCUPFSG5430	619	51.75	30	20	34.95	17.97
GCUPFSG5436	668	51.75	36	20	39.07	21.56
GCUPFSG5442	717	51.75	42	20	43.19	25.16
GCUPFSG5448	766	51.75	48	20	47.31	28.75
GCUPFSG5460	864	51.75	60	20	55.56	35.94
GCUPFSG6024	604	57.75	24	20	33.11	16.04
GCUPFSG6030	657	57.75	30	20	37.74	20.05
GCUPFSG6036	712	57.75	36	20	42.36	24.06
GCUPFSG6042	765	57.75	42	20	46.99	28.07
GCUPFSG6048	820	57.75	48	20	51.61	32.08
GCUPFSG6060	928	57.75	60	20	60.86	40.10

GCUPMSG • Freestanding Divider Glass Screen with Casters

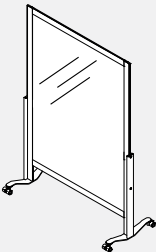

- Provides privacy and room separation.
- Lightweight and easy to clean and move.
- Consists of an aluminum frame, clear glass screen and steel flat feet.
- Please choose any standard panel frame paint finish from Global Contract for all metal parts.
- Option for 54" / 60" high.
- Upcharge for frosted (FRST) glass is 20%.

PRODUCT CODE	PRICE	SIZE/INCHES			WEIGHT LBS	VOL FT ³
		H	W	D		
GCUPMSG5424	817	52.05	24	20	31.99	14.46
GCUPMSG5430	865	52.05	30	20	36.11	18.07
GCUPMSG5436	915	52.05	36	20	40.24	21.69
GCUPMSG5442	963	52.05	42	20	44.36	25.30
GCUPMSG5448	1012	52.05	48	20	48.48	28.92
GCUPMSG5460	1110	52.05	60	20	56.72	36.15
GCUPMSG6024	850	58.05	24	20	34.28	16.13
GCUPMSG6030	904	58.05	30	20	38.9	20.16
GCUPMSG6036	958	58.05	36	20	43.53	24.19
GCUPMSG6042	1011	58.05	42	20	48.15	28.22
GCUPMSG6048	1065	58.05	48	20	52.78	32.25
GCUPMSG6060	1174	58.05	60	20	62.03	40.31

GCUPSHG • Shared Divider Glass Screen

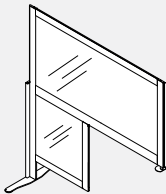

- Provides privacy and divides space for workstations.
- Divider stands on the floor and sits on the worksurface.
- Has no mechanical connection to any surface.
- Lightweight and easy to clean and move.
- Consists of a powder coated aluminum frame, clear glass screen and steel flat foot.
- Option for 54" / 60" high.
- Extends 24" from the worksurface.
- Sits 24" or 30" above worksurface.
- Please choose any standard paint finish for frame and feet.
- Upcharge for frosted (FRST) glass is 20%.

PRODUCT CODE	PRICE	SIZE/INCHES			WEIGHT LBS	VOL FT ³
		H	W	D		
GCUPSHG5448	629	53.57	48	20	36.17	29.76
GCUPSHG5454	657	53.57	54	20	38.51	33.48
GCUPSHG6048	680	59.57	48	20	40.52	33.09
GCUPSHG6054	714	59.57	54	20	43.36	37.23