

INSTALLATION GUIDELINES

Privacy Screen

The Privacy Screen provides enclosure and semi-privacy to a station.

Privacy Screen can be mounted “on module” only onto 36” and 42” wide panels, minimum height of 66”.

STEP 1: Determine the top and bottom of the Privacy Screen. The brackets with three teeth go at the top, while the brackets with two teeth go at the bottom.

STEP 2: Determine if the Privacy Screen is a left or a right. The direction of the slide determines this. The Privacy Screen is mounted to the panel directly beside the opening, OPPOSITE to the direction of the slide.

STEP 3: Ensuring the door is level, insert the upper teeth into the panel at the appropriate height. (Uppermost slot on 66” high panels.)

STEP 4: Ensuring all four bracket positions are lined up to their intended slots, push the brackets in and down.

Be careful, the sliding door can easily move on its Screen Slides.

STEP 5: Push the rotating clips on all four brackets into the panel slots. The clips prevent dislodgment of the brackets.

STEP 6: Upon completion, ensure the door operates properly across the full length of the Screen Slide.

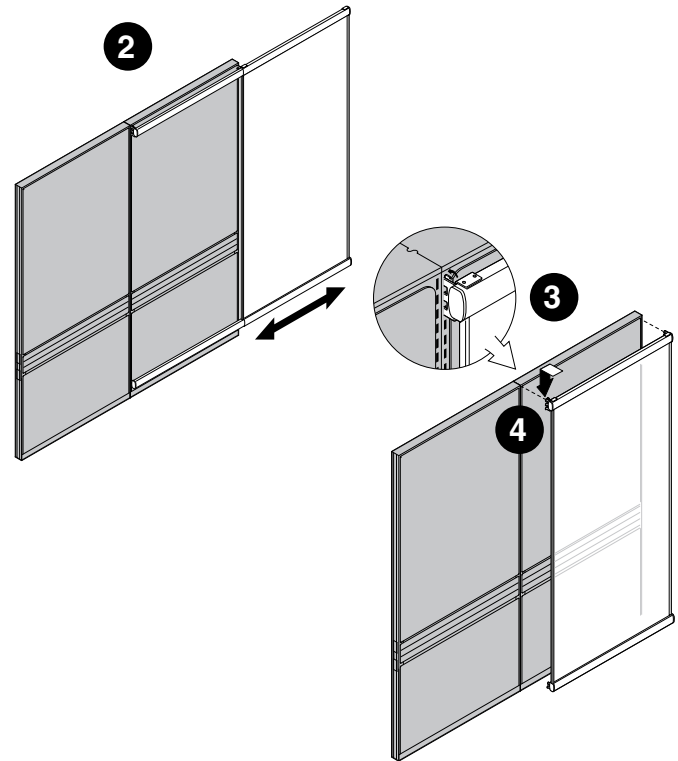

Privacy Screen Lock Assembly Kit

In order to install the Striker Plate Bracket, make sure that the Privacy Screen is securely connected to leveled panels and that all anti-dislodgment plates on each screen slide-hanging bracket are engaged in panel slots.

STEP 1: Align the bottom of the Striker Plate Bracket bottom tooth with the bottom of the slot in panel's vertical extrusion, approximately 35” above floor level.

STEP 2: Mark the bottom and top of the bracket on the soft, slot-covering part of the Panel Capture Strip and cut the soft part of the capture strip away.

STEP 3: Engage both teeth into the panel slots and tap lightly until the bottom of both teeth is resting on the bottom edge of both panel slots.

STEP 4: Push the rotating clip into the panel slot. The clip prevents dislodgment of the bracket.

STEP 6: Align the Lock Bracket with the Striker Plate Bracket. Hold the Lock Bracket against the Sliding Screen.

NOTE: The Lock Bracket assembly must be flush with the inner (acrylic) side of the screen.

STEP 7: Mark location of both holes.

NOTE: Before you drill, ensure that the marks are closer to the inside acrylic side of the Privacy screen.

STEP 8: Drill 1/8” pilot holes. Do not push on the drill. While drilling, be careful not to force any Aluminum shavings into the interior of the acrylic flutes as they may become visible.

STEP 9: Secure the Lock Bracket with supplied screws (#8-1/2”).

STEP 10: Test the Lock function and snap in plastic Lock Assembly Cover.

