



Filing & Storage

12 Series Laterals



12 Series filing and storage cabinet's horizontal lines are uniform and consistent providing the cabinets with a clean flowing esthetic. Locks are located at AODA/ADA compliant position for easy access.



All lateral file cabinets are of welded construction using 18 to 22 gauge cold rolled steel. Front corners are mig-welded and ground smooth where the case meets the top and bottom. Positive interlocking system is integrated into each drawer for safety.

Custom colours at no charge, except metallic.

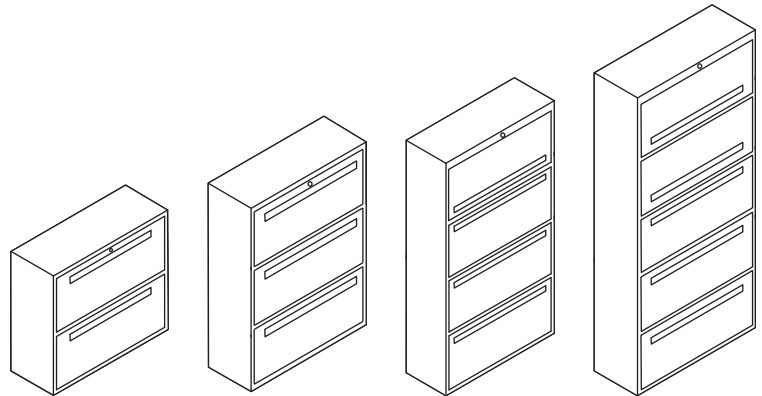

In order to meet ANSI/BIFMA X5.9-2012, Counterweight must be incorporated.